



Chipsmall Limited consists of a professional team with an average of over 10 year of expertise in the distribution of electronic components. Based in Hongkong, we have already established firm and mutual-benefit business relationships with customers from,Europe,America and south Asia,supplying obsolete and hard-to-find components to meet their specific needs.

With the principle of “Quality Parts,Customers Priority,Honest Operation,and Considerate Service”,our business mainly focus on the distribution of electronic components. Line cards we deal with include Microchip,ALPS,ROHM,Xilinx,Pulse,ON,Everlight and Freescale. Main products comprise IC,Modules,Potentiometer,IC Socket,Relay,Connector.Our parts cover such applications as commercial,industrial, and automotives areas.

We are looking forward to setting up business relationship with you and hope to provide you with the best service and solution. Let us make a better world for our industry!



Contact us

Tel: +86-755-8981 8866 Fax: +86-755-8427 6832

Email & Skype: info@chipsmall.com Web: www.chipsmall.com

Address: A1208, Overseas Decoration Building, #122 Zhenhua RD., Futian, Shenzhen, China



POWER MANAGEMENT

Features

- Power system
 - Input voltage — 3V to 28V
 - Integrated bootstrap switch
 - Programmable LDO output — 200mA
 - 1% reference tolerance -40 to +85 °C
 - Selectable internal/external bias power supply
 - EcoSpeed™ architecture with pseudo-fixed frequency adaptive on-time control
- Logic input/output control
 - Independent control EN for LDO and switcher
 - Programmable V_{IN} UVLO threshold
 - Power good output
 - Selectable power save mode
 - Programmable ultrasonic power save mode
- Protections
 - Over-voltage/under-voltage
 - TC compensated $R_{DS(ON)}$ sensed current limit
 - Thermal shutdown
 - Smart power save
- Output capacitor types
 - High ESR — SP, POSCAP, OSCON
 - Ceramic capacitors
- Package — 3 x 3mm, 20-pin MLPQ
- Lead-free and halogen free
- RoHS and WEEE compliant

Applications

- Office automation and computing
- Networking and telecommunication equipment
- Point-of-load power supplies and module replacement

Description

The SC418 is a synchronous EcoSpeed™ buck regulator which incorporates Semtech’s advanced, patented adaptive on-time control architecture to provide excellent light-load efficiency and fast transient response. It features an integrated bootstrap switch and programmable LDO in a 3 x 3mm package. The device is highly efficient and uses minimal PCB area.

The SC418 supports using standard capacitor types such as electrolytic or special polymer, in addition to ceramic, at switching frequencies up to 1MHz. The programmable frequency, synchronous operation, and programmable power-save provide high efficiency operation over a wide load range.

Additional features include cycle-by-cycle current limit, soft-start, under and over-voltage protection, programmable over-current protection, soft shutdown, selectable power-save modes, and programmable ultrasonic power-save. The device also provides separate enable inputs for the PWM controller and LDO as well as a power good output for the PWM controller.

The input voltage can range from 3V to 28V. The wide input voltage range, programmable frequency, and programmable LDO make the device extremely flexible and easy to use in a broad range of applications. Support is provided for single cell or multi-cell battery systems in addition to traditional DC power supply applications.

Typical Application Circuit

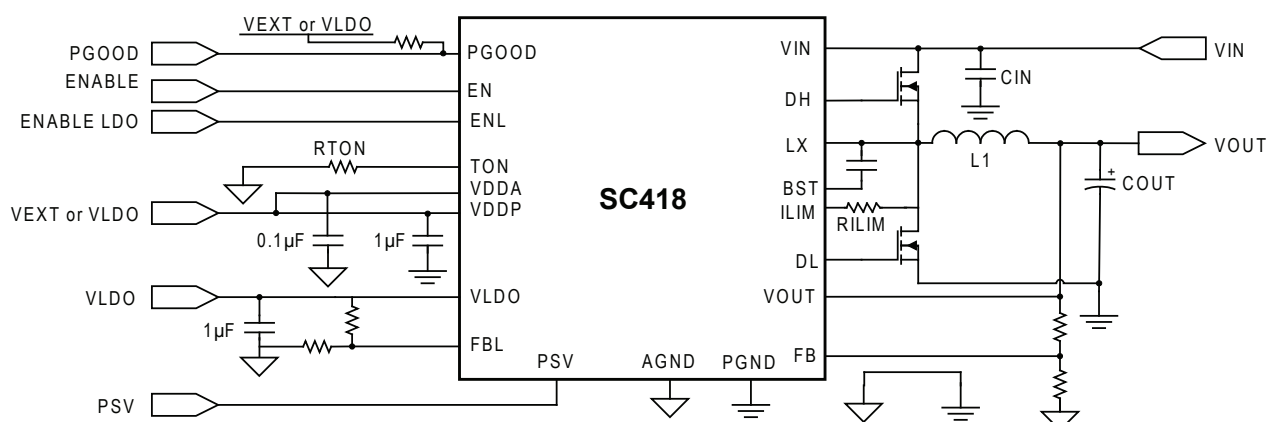

Pin Configuration

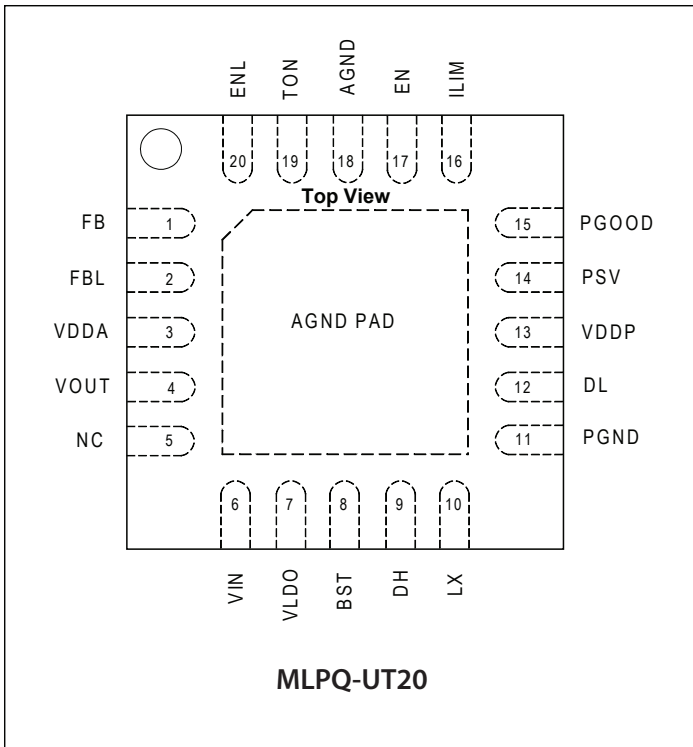

Ordering Information

| Device | Package |
|------------------------------|------------------|
| SC418ULTRT ⁽¹⁾⁽²⁾ | MLPQ-UT20 |
| SC418EVB | Evaluation Board |

Notes:

- 1) Available in tape and reel only. A reel contains 3000 devices.
- 2) Lead-free packaging only. Device is WEEE and RoHS compliant and halogen-free.

Marking Information

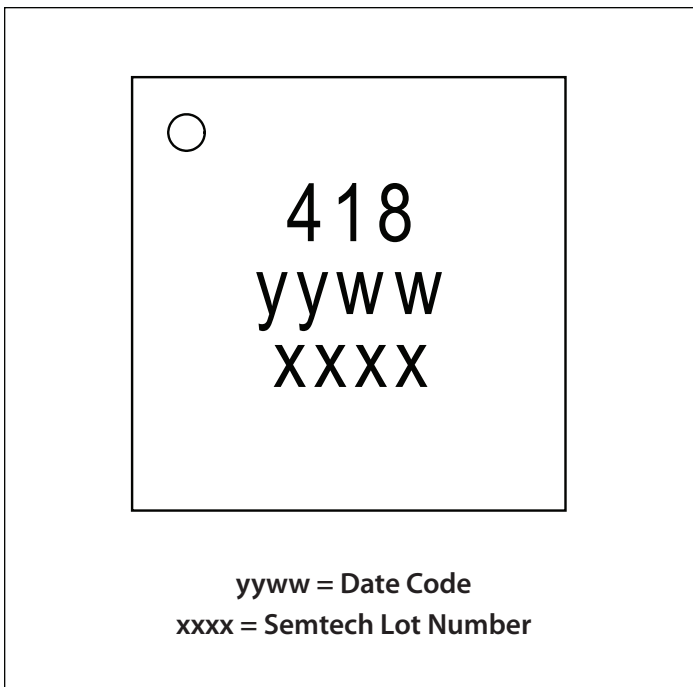

Absolute Maximum Ratings⁽¹⁾

| | |
|--|-----------------------|
| LX to PGND (V)..... | -0.3 to +30 |
| LX to PGND (V) (transient — 100ns) | -2 to +30 |
| DH, BST to PGND (V) | -0.3 to +35 |
| DH, BST to LX (V) | -0.3 to +6 |
| DL to PGND (V) | -0.3 to +6 |
| VIN to PGND (V)..... | -0.3 to +30 |
| EN, FB, FBL, ILIM to AGND (V) | -0.3 to +(VDDA + 0.3) |
| PGOOD, PSV, TON to AGND (V) | -0.3 to +(VDDA + 0.3) |
| VLDO, VOUT to AGND (V) | -0.3 to +(VDDA + 0.3) |
| TON to AGND (V)..... | -0.3 to +(VDDA - 1.5) |
| ENL to AGND (V) | -0.3 to VIN |
| VDDP to PGND, VDDA to AGND (V) | 0.3 to +6 |
| VDDA to VDDP (V) | -0.3 to +0.3 |
| AGND to PGND (V)..... | -0.3 to +0.3 |

Recommended Operating Conditions

| | |
|--------------------------------------|------------|
| Input Voltage (V) | 3.0 to 28 |
| VDDA to AGND, VDDP to PGND (V) | 3.0 to 5.5 |
| VOUT to PGND (V) | 0.5 to 5.5 |

Thermal Information

| | |
|--|-------------|
| Storage Temperature (°C)..... | -60 to +150 |
| Maximum Junction Temperature (°C) | 150 |
| Operating Junction Temperature (°C) | -40 to +125 |
| Thermal resistance, junction to ambient ⁽²⁾ (°C/W)..... | 50 |
| Peak IR Reflow Temperature (°C)..... | 260 |

Exceeding the above specifications may result in permanent damage to the device or device malfunction. Operation outside of the parameters specified in the Electrical Characteristics section is not recommended.

NOTES:

- (1) This device is ESD sensitive. Use of standard ESD handling precautions is required.
- (2) Calculated from package in still air, mounted to 3 x 4.5 (in), 4 layer FR4 PCB with thermal vias under the exposed pad per JESD51 standards.

Electrical Characteristics

Unless specified: $V_{IN} = 12V$, $VDDA = VDDP = 5V$, $T_A = +25^\circ C$ for Typ, -40 to $+85^\circ C$ for Min and Max, $T_J < 125^\circ C$, Typical Application Circuit

| Parameter | Conditions | Min | Typ | Max | Units |
|-----------------------------------|--|-------|------|-------|---------|
| Input Supplies | | | | | |
| Input Supply Voltage | | 3 | | 28 | V |
| VIN UVLO Threshold ⁽¹⁾ | Sensed at ENL pin, rising edge | 2.40 | 2.60 | 2.95 | V |
| | Sensed at ENL pin, falling edge | 2.235 | 2.40 | 2.565 | |
| VIN UVLO Hysteresis | Sensed at ENL pin; EN = 5V | | 0.2 | | V |
| VDDA UVLO Threshold | Measured at VDDA pin, rising edge | 2.50 | 2.90 | 3.05 | V |
| | Measured at VDDA pin, falling edge | 2.40 | 2.70 | 2.90 | |
| VDDA UVLO Hysteresis | | | 0.2 | | V |
| VIN Supply Current | Shutdown mode; ENL, EN = 0V | | 8.5 | 20.0 | μA |
| | Standby mode; VDDA = VDDP = ENL = 5V, EN = 0V, ignore LDO FB resistor bias current | | 130 | | |

Electrical Characteristics (continued)

| Parameter | Conditions | Min | Typ | Max | Units |
|--|--|-------|-------|-------|-------|
| Input Supplies (continued) | | | | | |
| VDDA + VDDP Supply Current | ENL, EN = 0V | | 3 | 7 | μA |
| | EN = 5V, R _{PSV} = 115kΩ, V _{FB} > 500mV ⁽²⁾ | | 1.5 | | mA |
| | EN = 5V, PSV = open (float), V _{FB} > 500mV ⁽²⁾ | | 0.4 | | |
| | Operating f _{sw} = 250kHz, PSV = VDDA, no load ⁽²⁾ | | 10 | | |
| FB Comparator Threshold | Static VIN and load, 0 to +85 °C | 0.496 | 0.500 | 0.504 | V |
| | Static VIN and load, -40 to +85 °C | 0.495 | | 0.505 | V |
| Frequency Range | Continuous mode operation | | | 1000 | kHz |
| Timing | | | | | |
| On-Time | Forced continuous mode operation, V _{IN} = 15V, V _{OUT} = 5V, R _{TON} = 300kΩ, VDDA = 5V | 2385 | 2650 | 2915 | ns |
| | VDDA < 4.5V ⁽³⁾ | | | | |
| Minimum On-Time ⁽²⁾ | | | 80 | | ns |
| Minimum Off-Time ⁽²⁾ | | | 250 | | ns |
| Ultrasonic Frequency ⁽²⁾ | Minimum switching frequency, R _{PSV} = 115kΩ | | 25 | | kHz |
| Soft-Start | | | | | |
| Soft-Start Ramp Time ⁽²⁾ | V _{OUT} ramp from zero to programmed value | | 850 | | μs |
| Analog Inputs/Outputs | | | | | |
| VOUT Input Resistance | | | 500 | | kΩ |
| Current Sense | | | | | |
| Zero Cross Detector Threshold | LX - PGND, VDDA = 5V | -3 | 0 | +3 | mV |
| Power Good | | | | | |
| Power Good Threshold | Upper limit, V _{FB} > internal 500mV reference | | +20 | | % |
| | Lower limit, V _{FB} < internal 500mV reference | | -10 | | % |
| Start-Up Delay Time | Includes Soft-Start Ramp Time, VDDA = 5V | | 2 | | ms |
| | Includes Soft-Start Ramp Time, VDDA = 3.3V ⁽²⁾ | | 1 | | |
| Fault (noise immunity) Delay Time ⁽²⁾ | | | 5 | | μs |
| Leakage | PGOOD = high impedance (open) | | | 1 | μA |
| Power Good On Resistance | | | 10 | | Ω |

Electrical Characteristics (continued)

| Parameter | Conditions | Min | Typ | Max | Units |
|---|---|-------|------|-------|-----------------|
| Fault Protection | | | | | |
| I_{LIM} Source Current | | 9 | 10 | 11 | μ A |
| I_{LIM} Source Current Temperature Coefficient ⁽²⁾ | | | 0.41 | | %/ $^{\circ}$ C |
| I_{LIM} Comparator Offset | With respect to AGND | -8 | 0 | +8 | mV |
| Output Under-Voltage Threshold | V_{FB} with respect to internal 500mV reference, 8 consecutive cycles | | -25 | | % |
| Smart Power-Save Protection Threshold ⁽²⁾ | V_{FB} with respect to internal 500mV reference | | +10 | | % |
| Over-Voltage Protection Threshold | V_{FB} with respect to internal 500mV reference | | +20 | | % |
| Over-Voltage Fault Delay ⁽²⁾ | | | 5 | | μ s |
| Over-Temperature Shutdown ⁽²⁾ | 10 $^{\circ}$ C hysteresis | | 150 | | $^{\circ}$ C |
| Logic Inputs/Outputs | | | | | |
| Logic Input High Voltage - EN, ENL ⁽⁴⁾ | | 1.0 | | | V |
| Logic Input High Voltage - PSV | Forced continuous mode operation; PSV with respect to VDDA | -0.4 | | | V |
| Logic Input Low Voltage - EN, ENL | With respect to AGND | | | 0.4 | V |
| EN Input Bias Current | EN = VDDA or AGND | -10 | | +10 | μ A |
| ENL Input Bias Current | $V_{IN} = 28V$ | -1 | 11 | +18 | μ A |
| FB, FBL Input Bias Current | FB, FBL = VDDA or AGND | -1 | | +1 | μ A |
| PSV Input Bias Current | PSV = VDDA | | 1 | | μ A |
| Linear Dropout Regulator | | | | | |
| FBL Accuracy | VLDO load = 10mA | 0.735 | 0.75 | 0.765 | V |
| Current Limit | Start-up and foldback; $V_{LDO} \leq 90\%$ of programmed value | | 115 | | mA |
| | Operating | 135 | 200 | | |
| VLDO to VOUT Switch-over Threshold ⁽⁵⁾ | | -140 | | +140 | mV |
| VLDO to VOUT Non-switch-over Threshold ⁽⁵⁾ | | -450 | | +450 | mV |
| VLDO to VOUT Switch-over Resistance | $V_{LDO} = V_{OUT} = 5V$ | | 2.0 | | Ω |
| | $V_{LDO} = V_{OUT} = 3.3V^{(6)}$ | | 2.2 | | |
| LDO Drop Out Voltage ⁽⁶⁾ | V_{IN} to V_{VLDO} , $V_{VLDO} = 5V$, VLDO load = 100mA | | 1.2 | | V |

Electrical Characteristics (continued)

| Parameter | Conditions | Min | Typ | Max | Units |
|--|--|-----|------|------|----------|
| High-Side Driver (DH, BST, LX) | | | | | |
| Peak Current ⁽²⁾ | VDDP = 5V | | 2.0 | | A |
| On Resistance | $R_{DH_PULL-UP}$, LX < 0.5V, VDDP = 5V | | 3.0 | 6.0 | Ω |
| | $R_{DH_PULL-UP}$, LX > 0.5V, VDDP = 5V | | 1.0 | 2.0 | Ω |
| | $R_{DH_PULL-DOWN}$, VDDP = 5V | | 0.6 | 1.2 | Ω |
| Rise Time ⁽²⁾ | $C_{DH-LX} = 3nF$, VDDP = 5V | | 22 | | ns |
| Fall Time ⁽²⁾ | $C_{DH-LX} = 3nF$, VDDP = 5V | | 12 | | ns |
| Propagation Delay ⁽²⁾ | From FB Comparator Input to DH | 30 | 45 | 60 | ns |
| Shoot-thru Protection Delay ⁽²⁾ | | 10 | 20 | 30 | ns |
| Bootstrap Switch Resistance | | | 10 | | Ω |
| Low-Side Driver (DL, VDDP, PGND) | | | | | |
| Peak Current ⁽²⁾ | VDDP = 5V | | 4.0 | | A |
| On Resistance | $R_{DL_PULL-UP}$, VDDP = 5V | | 1.3 | 2.1 | Ω |
| | $R_{DL_PULL-DOWN}$, VDDP = 5V | | 0.50 | 0.86 | Ω |
| Rise Time ⁽²⁾ | $C_{DL} = 3nF$, VDDP = 5V | | 7 | | ns |
| Fall Time ⁽²⁾ | $C_{DL} = 3nF$, VDDP = 5V | | 3.5 | | ns |

Notes:

- (1) VIN UVLO is programmable using a resistor divider from VIN to ENL to AGND. The ENL voltage is compared to an internal reference.
- (2) Guaranteed by design.
- (3) For VDDA less than 4.5V, the On-Time may be limited by the VDDA supply voltage and by V_{IN} . See the TON Limitations and VDDA Supply Voltage section in the Applications Information.
- (4) The ENL pin will enable the LDO with 1.0V typical. The ENL pin's VIN ULVO function will disable the switcher unless the ENL pin exceeds the V_{IN} UVLO Threshold (typical 2.5V).
- (5) The switch-over threshold is the maximum voltage differential between the VLDO and VOUT pins which ensures that VLDO will internally switch-over to VOUT. The non-switch-over threshold is the minimum voltage differential between the VLDO and VOUT pins which ensures that VLDO will not switch-over to VOUT.
- (6) The LDO drop out voltage is the voltage at which the LDO output drops 2% below the nominal regulation point.

Detailed Application Circuit

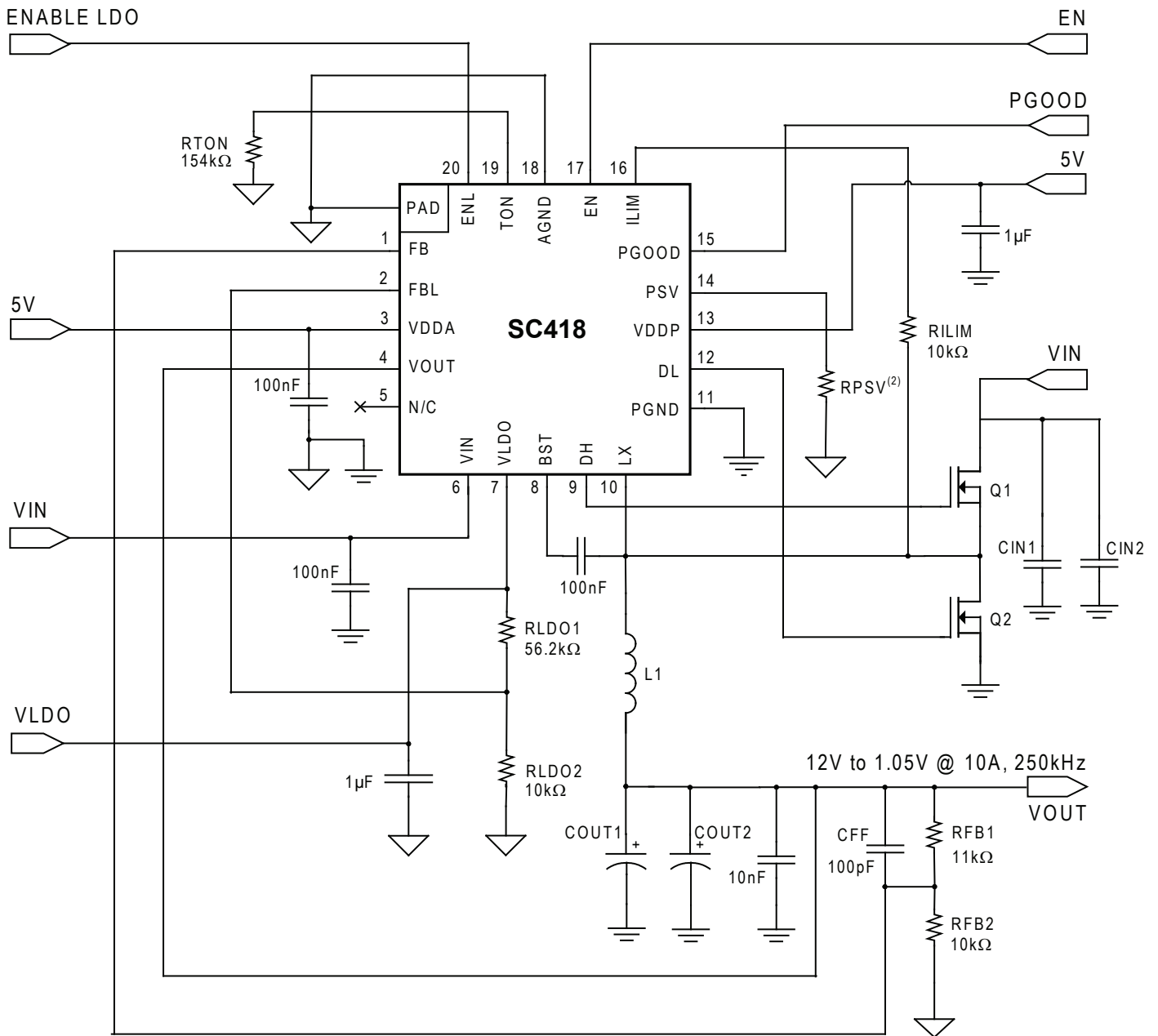

Key Components

| Component | Value | Manufacturer | Part Number | Web |
|---------------|--------------------------------|--------------|--------------------|--|
| CIN1, CIN2 | 10 μ F/25V | Murata | GRM32DR71E106KA12L | www.murata.com |
| COUT1, COUT2 | 220 μ F/15m Ω /6.3V | Panasonic | EEFUE0J221 | www.panasonic.com |
| L1 (option 1) | 0.88 μ H/2.3m Ω | NEC-Tokin | MPC1040LR88C | www.nec-tokin.com |
| L1 (option 2) | 1.0 μ H/2.3m Ω | Vishay | IHLP4040DZER1ROM11 | www.vishay.com |
| Q1 | IRF7821 | I.R. | IRF7821 | www.irf.com |
| Q2 | IRF7832 | I.R. | IRF7832 | www.irf.com |

Typical Characteristics

Characteristics in this section are based on using the Detailed Application Circuit.

Efficiency vs. Load — Forced Continuous Mode

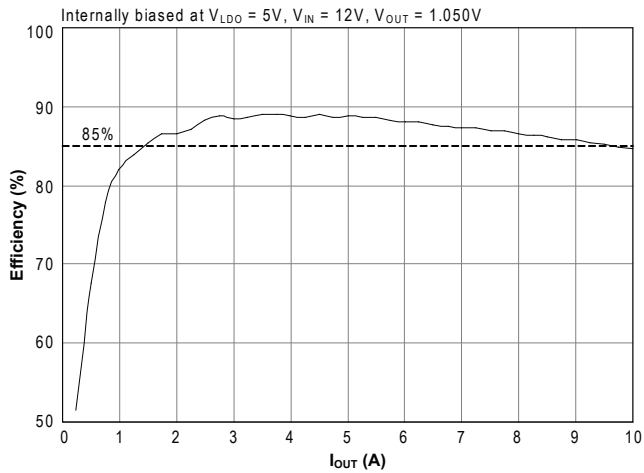

V_{OUT} vs. Load — Forced Continuous Mode

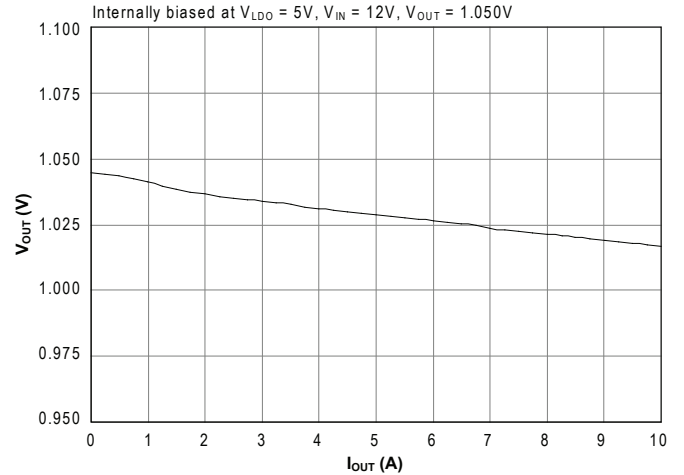

Efficiency vs. Load — Ultrasonic Power-save Mode

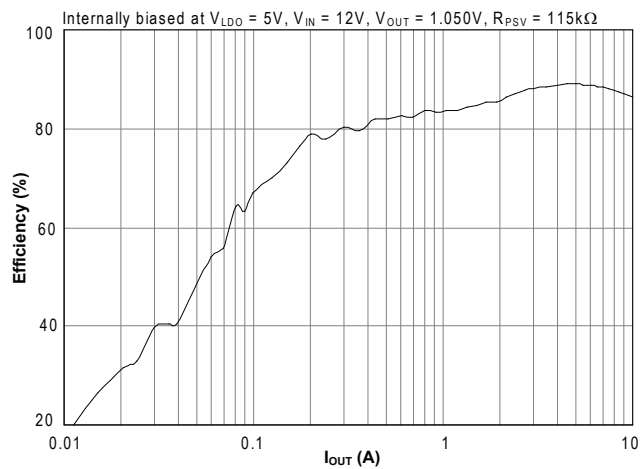

V_{OUT} vs. Load — Ultrasonic Power-save Mode

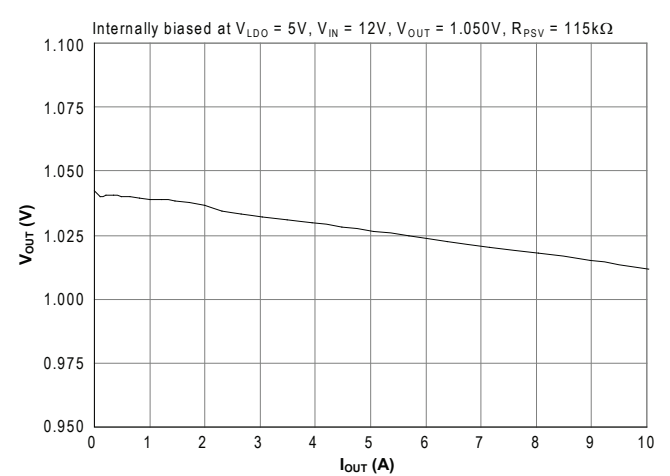

Efficiency vs. Load — Power-save Mode

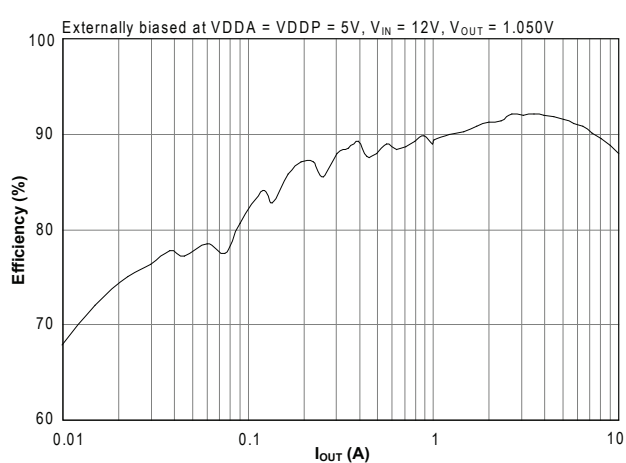

V_{OUT} vs. Load — Power-save Mode

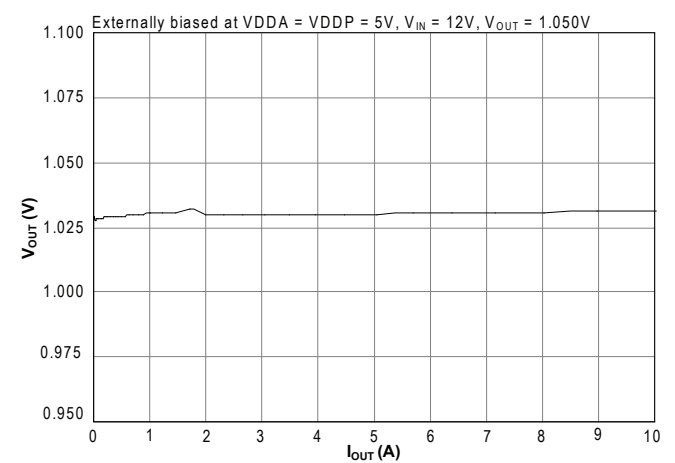

Typical Characteristics (continued)

Characteristics in this section are based on using the Detailed Application Circuit.

Forced Continuous Mode — No Load

Internally biased at $V_{LDO} = 5V$, $V_{IN} = 12V$, $V_{OUT} = 1.050V$, $I_{OUT} = 0A$

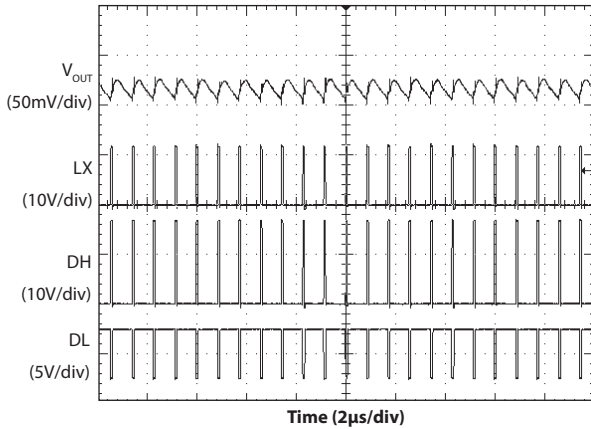

Transient Response — Load Rising

Externally biased at $V_{DDA}/V_{DDP} = 5V$, $V_{IN} = 12V$, $V_{OUT} = 1.050V$, $I_{OUT} = 0A$ to $10A$

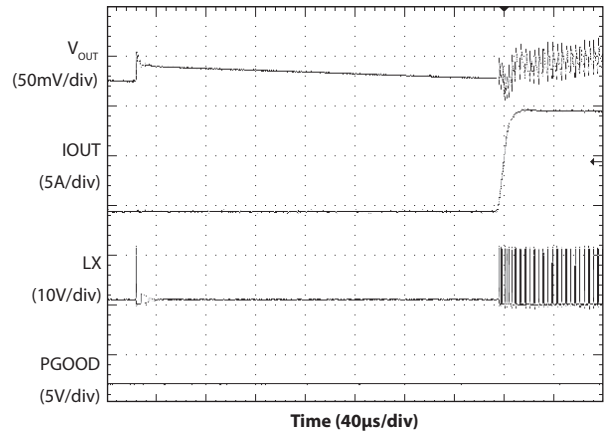

Ultrasonic Powersave Mode — No Load

Internally biased at $V_{LDO} = 5V$, $V_{IN} = 12V$, $V_{OUT} = 1.050V$, $R_{PSV} = 115k\Omega$

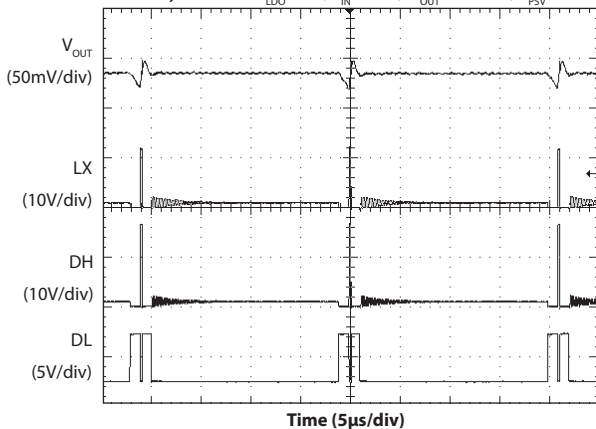

Transient Response — Load Falling

Externally biased at $V_{DDA}/V_{DDP} = 5V$, $V_{IN} = 12V$, $V_{OUT} = 1.050V$, $I_{OUT} = 10A$ to $0A$

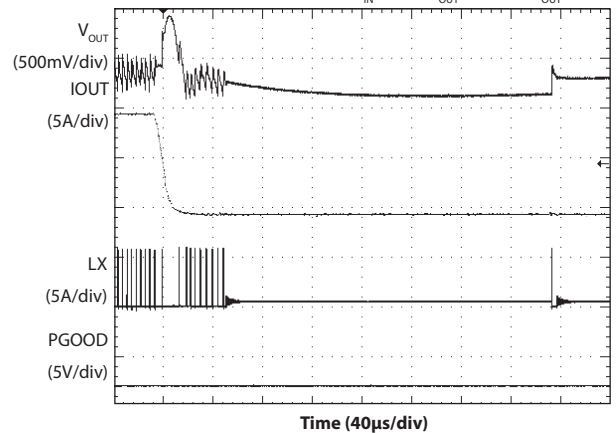

Power-Save Mode — No Load

Externally biased at $V_{DDA}/V_{DDP} = 5V$, $V_{IN} = 12V$, $V_{OUT} = 1.050V$

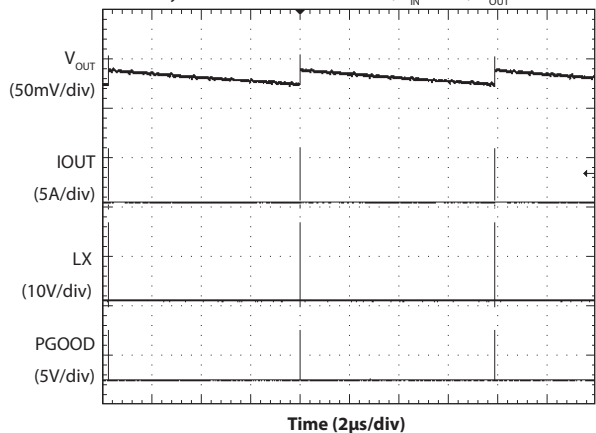

Enabled Loaded Output — Power Good True

Internally biased at $V_{LDO} = 5V$, $V_{IN} = 12V$, $V_{OUT} = 1.050V$, $I_{OUT} = 0A$

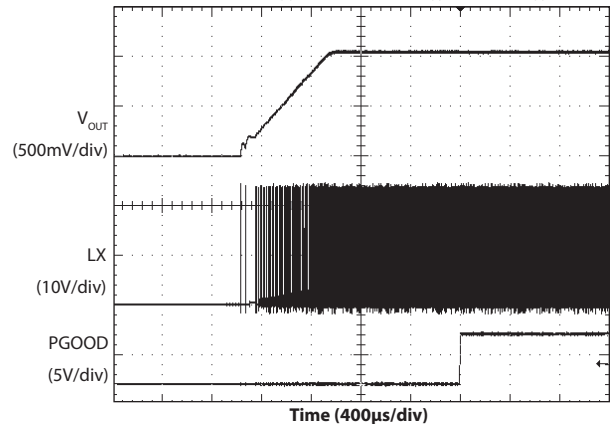

Typical Characteristics (continued)

Characteristics in this section are based on using the Detailed Application Circuit.

Frequency vs. Load — Forced Continuous Mode

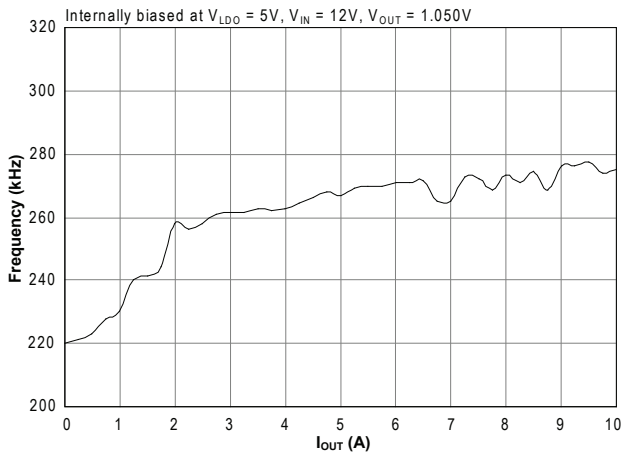

V_{RIPPLE} vs. Load — Forced Continuous Mode

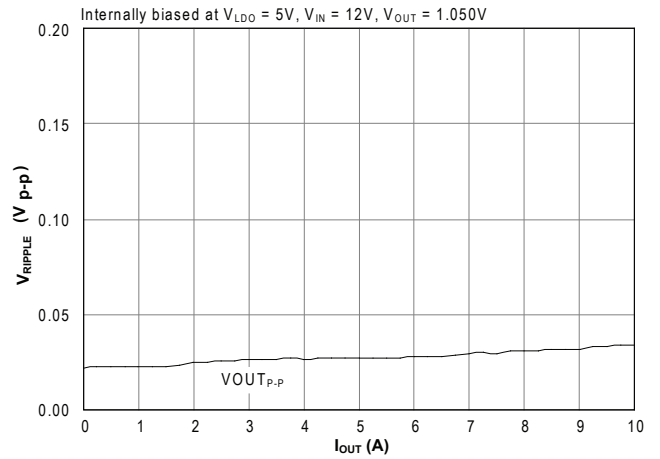

Frequency vs. Load — Ultrasonic Power-Save Mode

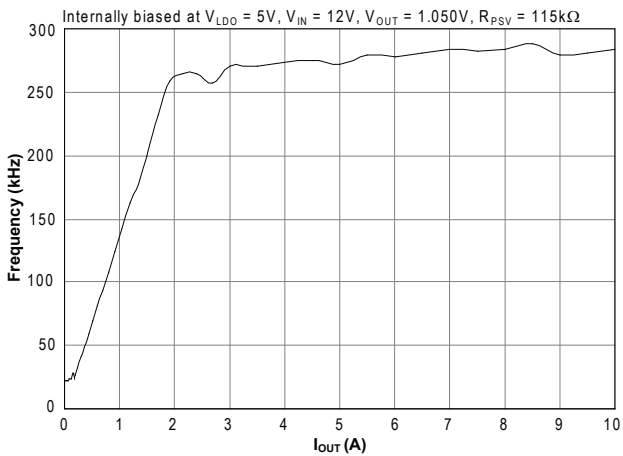

Output Over-Current Response — Normal Operation

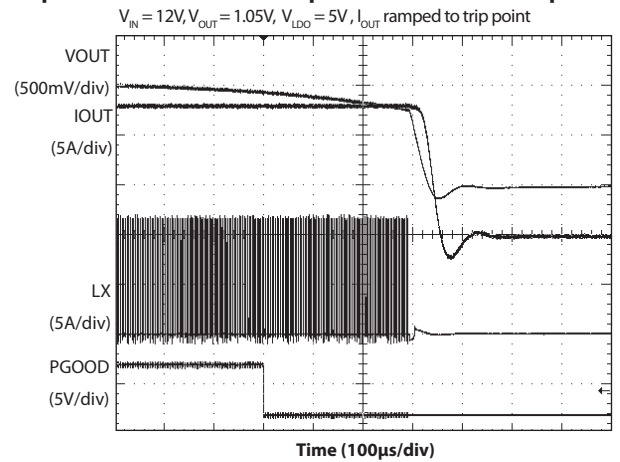

Frequency vs. Load — Power-Save Mode

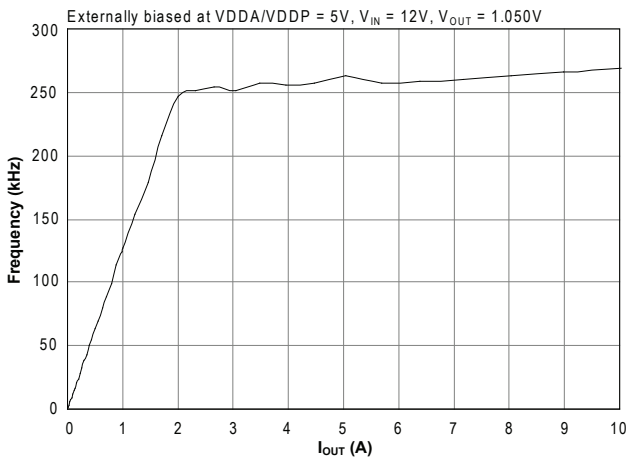

Pin Descriptions

| Pin # | Pin Name | Pin Function |
|-------|----------|--|
| 1 | FB | Feedback input for switching regulator — connect to an external resistor divider from output — used to program the output voltage. |
| 2 | FBL | Feedback input for the LDO — connect to an external resistor divider from VLDO to AGND — used to program the LDO output. |
| 3 | VDDA | Supply input for internal analog circuits — connect to external 3.3V or 5V supply, or configure the LDO for 3.3V or 5V and connect to VLDO — also the sense input for VDDA UVLO. |
| 4 | VOUT | Switcher output voltage sense pin — also the input to the internal switch-over MOSFET between VOUT and VLDO. The voltage at this pin must be less than or equal to the voltage at the VDDA pin. |
| 5 | NC | No Connection |
| 6 | VIN | Input supply voltage — connect to the same supply used for the high-side MOSFET. Connect a 100nF capacitor from this pin to AGND. |
| 7 | VLDO | LDO output — The voltage at this pin must be less than or equal to the voltage at the VDDA pin. |
| 8 | BST | Bootstrap pin — connect a 100nF minimum capacitor from BST to LX to develop the floating voltage for the high-side gate drive. |
| 9 | DH | High-side gate drive output |
| 10 | LX | Switching (phase) node |
| 11 | PGND | Power ground |
| 12 | DL | Low-side gate drive output |
| 13 | VDDP | Supply input for the DH and DL gate drives — connect to the same 3.3V or 5V supply used for VDDA. |
| 14 | PSV | Power-save programming input — connect a resistor to AGND to set a minimum (ultrasonic) power-save frequency — float pin to select power-save with no minimum frequency — pull up to VDDA to disable power-save and select forced continuous mode. |
| 15 | PGOOD | Open-drain Power Good indicator — high impedance indicates the switching regulator output is good. An external pull-up resistor is required. |
| 16 | ILIM | Current limit sense pin — used to program the current limit by connecting a resistor from ILIM to LX. |
| 17 | EN | Enable input for switching regulator — logic low disables the switching regulator — logic high enables the switching regulator. |
| 18 | AGND | Analog ground |
| 19 | TON | ON time programming input — set the on-time by connecting through a resistor to AGND. |
| 20 | ENL | Enable input for the LDO and VIN UVLO input for the switching regulator — connect ENL to AGND to disable the LDO — drive to logic high (>3V) to enable the LDO and inhibit VIN UVLO — connect to resistor divider from VIN to AGND to program the V_{IN} UVLO threshold. |
| PAD | AGND | Analog ground |

Block Diagram

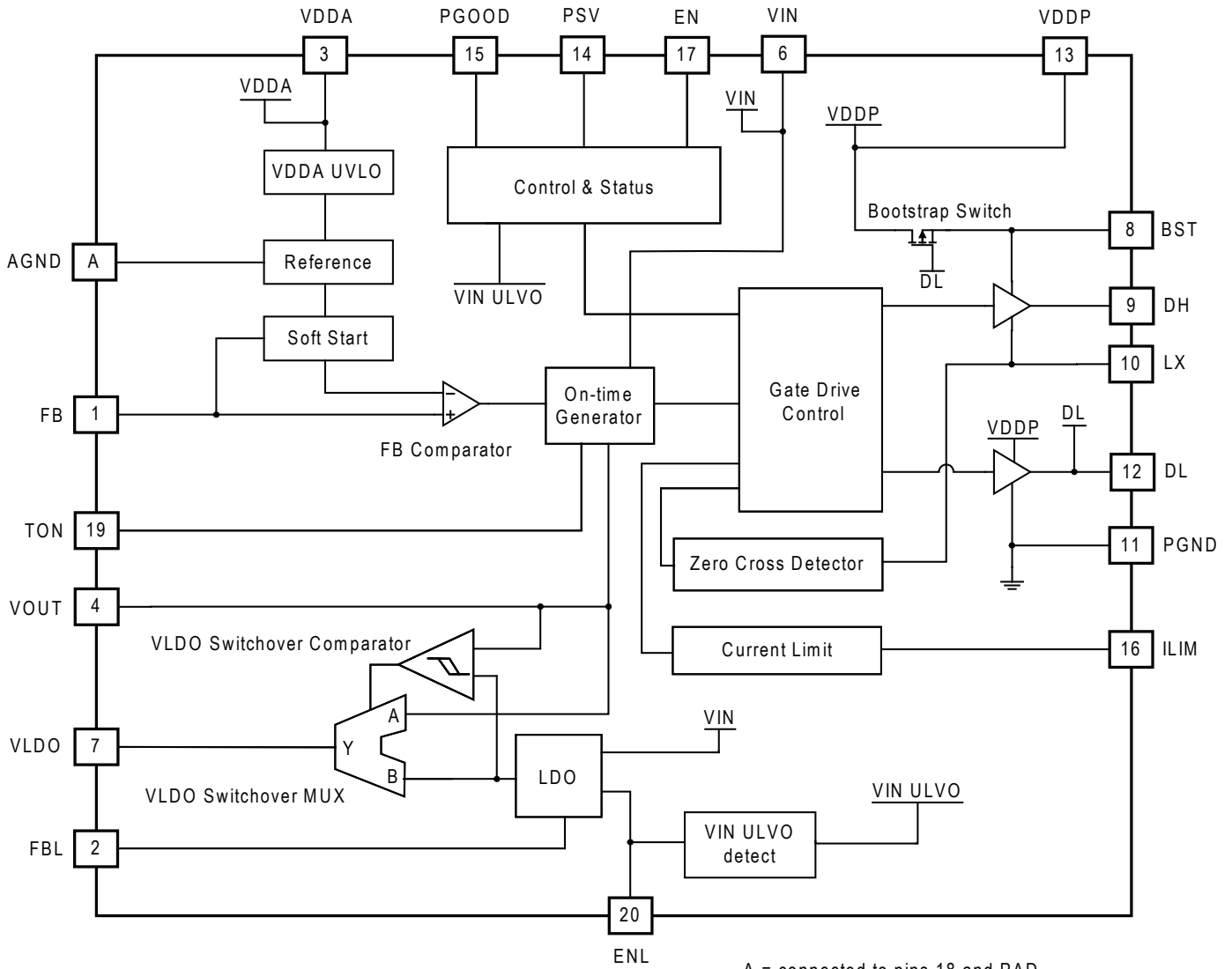

Applications Information

Synchronous Buck Converter

The SC418 is a step down synchronous DC-DC buck controller with a programmable LDO. It provides high efficiency operation in a space saving 3x3 (mm) 20-pin package. The programmable operating frequency range of 200kHz to 1MHz enables optimizing the configuration for PCB area and efficiency.

The controller uses a pseudo-fixed frequency adaptive on-time control. This allows fast transient response which permits the use of smaller output capacitors.

In addition to the following information, the user can click on the applicable link to go to the SC418 online [C-SIM design and simulation tool](#), which will lead the user through the design process.

Input Voltage Requirements

The SC418 requires three input supplies for normal operation: V_{IN} , VDDA, and VDDP. V_{IN} operates over the wide range of 3V to 28V. VDDA and VDDP require a 3.3V or 5V supply which can be from an external source or from the internal LDO configured to 3.3V or 5V. VDDA and VDDP should derive from the same source voltage. Power-save operation and Ultrasonic Power-save are not supported for VDDA/VDDP below 4.5V.

Pseudo-fixed Frequency Adaptive On-time Control

The PWM control method used by the SC418 is pseudo-fixed frequency, adaptive on-time, as shown in Figure 1. The ripple voltage generated at the output capacitor ESR is used as a PWM ramp signal. This ripple is used to trigger the on-time of the controller.

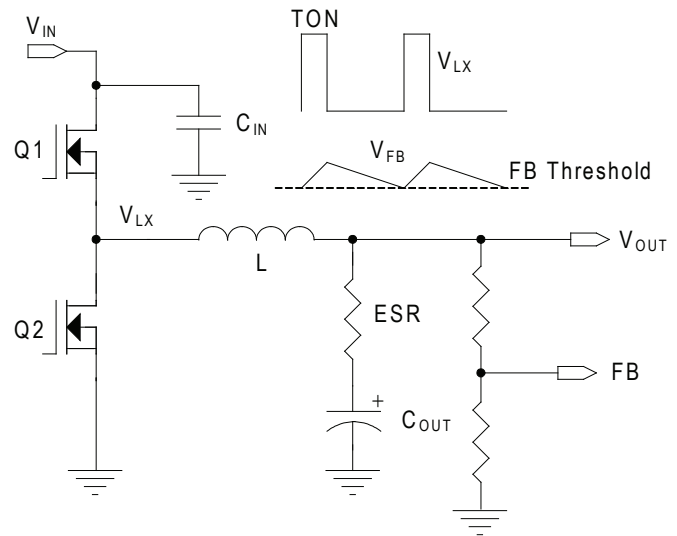

Figure 1 — PWM Control Method, V_{OUT} Ripple

The adaptive on-time is determined by an internal one-shot timer. When the one-shot is triggered by the output ripple, the device sends a single on-time pulse to the high-side MOSFET. The pulse period is determined by V_{OUT} and V_{IN} . The period is proportional to output voltage and inversely proportional to input voltage. With this adaptive on-time configuration, the device automatically anticipates the on-time needed to regulate V_{OUT} for the present V_{IN} condition and at the selected frequency.

The advantages of adaptive on-time control are:

- Predictable operating frequency compared to other variable frequency methods.
- Reduced component count by eliminating the error amplifier and compensation components.
- Reduced component count by removing the need to sense and control inductor current.
- Fast transient response — the response time is controlled by a fast comparator instead of a typically slow error amplifier.
- Reduced output capacitance due to fast transient response.

One-Shot Timer and Operating Frequency

One-shot timer operation is shown in Figure 2. The FB comparator output goes high when V_{FB} is less than the internal 500mV reference. This feeds into the DH gate drive and turns on the high-side MOSFET, and also starts the one-shot timer. The one-shot timer uses an internal

Applications Information (continued)

comparator and a capacitor. One comparator input is connected to V_{OUT} , the other input is connected to the capacitor. When the on-time begins, the internal capacitor charges from zero volts through a current which is proportional to V_{IN} . When the capacitor voltage reaches V_{OUT} , the on-time is completed and the high-side MOSFET turns off.

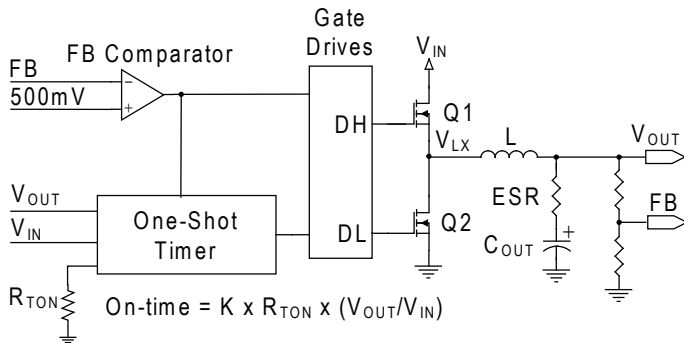

Figure 2 — On-Time Generation

This method automatically produces an on-time that is proportional to V_{OUT} and inversely proportional to V_{IN} . Under steady-state conditions, the switching frequency can be determined from the on-time by the following equation.

$$f_{SW} = \frac{V_{OUT}}{T_{ON} \times V_{IN}}$$

The SC418 uses an external resistor to set the on-time which indirectly sets the frequency. The on-time can be programmed to provide an operating frequency from 200kHz to 1MHz using a resistor between the TON pin and ground. The resistor value is selected by the following equation.

$$R_{TON} = \frac{(T_{ON} - 10ns) \times V_{IN}}{25pF \times V_{OUT}}$$

The maximum R_{TON} value allowed is shown by the following equation.

$$R_{TON_MAX} = \frac{V_{IN_MIN}}{15\mu A}$$

Immediately after the on-time, the DL output drives high to energize the low-side MOSFET. DL has a minimum high time of $\sim 250ns$, after which DL continues to stay high until one of the following occurs:

- VFB falls below the 500mV reference

- The Zero Cross Detector trips if power-save is active

TON Limitations and VDDA Supply Voltage

For VDDA below 4.5V, the TON accuracy may be limited by V_{IN} . The previous RTON equation is accurate if V_{IN} satisfies the below relation over the entire V_{IN} range:

$$V_{IN} < (VDDA - 1.6V) \times 10$$

If V_{IN} exceeds $((VDDA - 1.6V) \times 10)$ for all or part of the V_{IN} range, the previous RTON equation is not accurate. In all cases where $V_{IN} > ((VDDA - 1.6V) \times 10)$, the RTON equation must be modified as follows.

$$R_{TON} = \frac{(T_{ON} - 10ns) \times (V_{IN} - 1.6V) \times 10}{25pF \times V_{OUT}}$$

Note that when V_{IN} is greater than $((VDDA - 1.6V) \times 10)$, the actual on-time is fixed and does not vary with V_{IN} . When operating in this condition, the switching frequency will vary inversely with V_{IN} rather than approximating fixed frequency.

When a large capacitor is placed in parallel with R1 (CTOP) VOUT is shown by the following equation.

$$V_{OUT} = 0.5 \times \left(1 + \frac{R_1}{R_2} \right) + \left(\frac{V_{RIPPLE}}{2} \right) \times \sqrt{\frac{1 + (R_1 \omega C_{TOP})^2}{1 + \left(\frac{R_2 \times R_1}{R_2 + R_1} \omega C_{TOP} \right)^2}}$$

The switcher output voltage can be programmed higher than 5V with careful design. In this case the VOUT pin cannot connect directly to the switcher output due to its the maximum voltage rating. An additional resistor divider network is required to connect from the switcher output to the VOUT pin. The voltage at the VOUT pin should be at least 500mV lower than the VDDA supply, to prevent the VLDO switch-over function. For example, the voltage at the VOUT pin can be 4V if VDDA is set for 5V. When the SC418 operates from an external power source and the LDO is disabled by grounding the ENL pin, the voltage at the VOUT pin can be as high as shown in Recommended Operating Conditions. Note that RTON must be adjusted higher by the same divider ratio to

Applications Information (continued)

maintain the desired on-time; on-time is calculated according to the voltage at the VOUT pin.

V_{OUT} Voltage Selection

The switcher output voltage is regulated by comparing V_{OUT} as seen through a resistor divider at the FB pin to the internal 500mV reference voltage (see Figure 3).

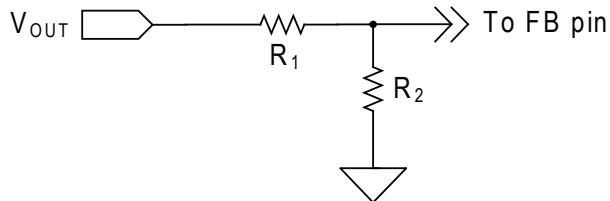

Figure 3 — Output Voltage Selection

Note that this control method regulates the valley of the output ripple voltage, not the DC value. The DC value of V_{OUT} is offset by the output ripple according to the following equation.

$$V_{OUT} = 0.5 \times \left(1 + \frac{R_1}{R_2} \right) + \left(\frac{V_{RIPPLE}}{2} \right)$$

Forced Continuous Mode Operation

The SC418 operates the switcher in Forced Continuous Mode (FCM) by connecting the PSV pin to VDDA. (The PSV pin should never exceed the VDDA supply.) See Figure 4 for FCM waveforms. In this mode one of the power MOSFETs is always on, with no intentional dead time other than to avoid cross-conduction. This results in more uniform frequency across the full load range with the trade-off being reduced efficiency at light loads due to the high-frequency switching of the MOSFETs.

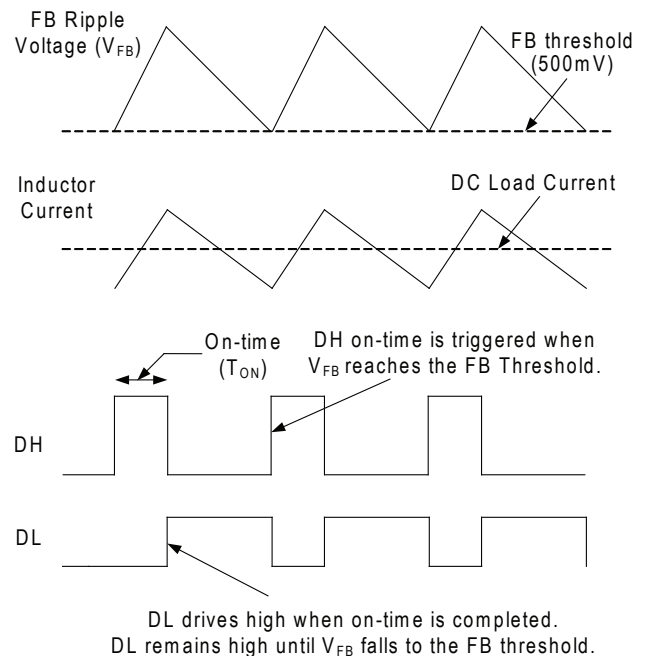

Figure 4 — Forced Continuous Mode Operation

Programmable Ultrasonic Power-Save Operation

The device provides programmable ultrasonic power-save operation at light loads; the minimum operating frequency is programmed by connecting a resistor from PSV to AGND. The SC418 uses the PSV resistor to set an internal timer that monitors the time between consecutive high-side gate pulses. If the time exceeds the programmed timer, DL drives high to turn the low-side MOSFET on. This draws current from V_{OUT} through the inductor, forcing both V_{OUT} and V_{FB} to fall. When V_{FB} drops to the 500mV threshold, the next DH on-time is triggered. After the on-time is completed the high-side MOSFET is turned off and the low-side MOSFET turns on, and the internal timer is restarted. The low-side MOSFET remains on until the inductor current ramps down to zero, at which point the low-side MOSFET is turned off. This ends the cycle until V_{FB} falls below the 500mV threshold, or the internal timer forces another DL turn-on.

Because the period between on-times is limited to a maximum value, a minimum operating frequency is maintained. Figure 5 shows ultrasonic power-save operation.

Applications Information (continued)

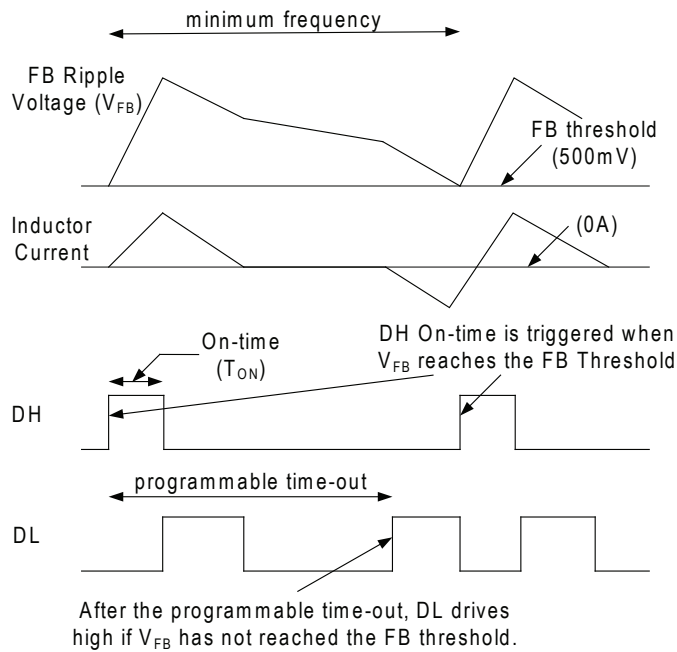

Figure 5 — Ultrasonic Power-Save Operation

The equation for determining the R_{PSV} resistor value is shown next. The desired minimum frequency is f_{SWMIN} .

$$R_{PSV} = \frac{1}{350pF \times f_{SWMIN}}$$

Power-Save Mode Operation

The device provides power-save operation at light loads with no minimum operating frequency, selected by floating the PSV pin (no connection). In this mode of operation, the zero cross comparator monitors inductor current via the voltage across the low-side MOSFET during the off-time. If the inductor current falls to zero for 8 consecutive switching cycles, the controller enters power-save operation. It will then turn off the low-side MOSFET on each subsequent cycle, provided that the current crosses zero. After the low-side MOSFET is off, both high-side and low-sides MOSFETs remain off until V_{FB} drops to the 500mV threshold. While the MOSFETs are off the load is supplied by the output capacitor. If the inductor current does not reach zero on any switching cycle, the controller immediately exits power-save and returns to forced continuous mode. Figure 6 shows power-save operation at light loads.

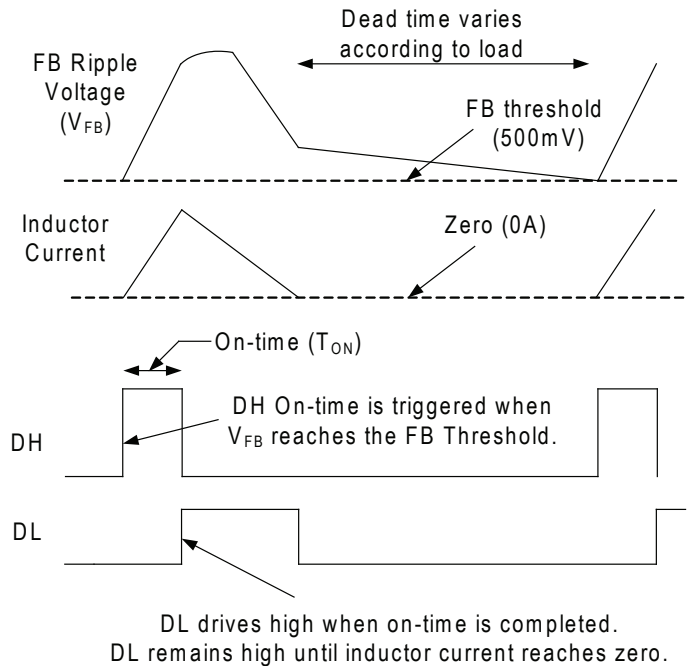

Figure 6 — Power-Save Operation

Smart Power-Save Protection

Active loads may leak current from a higher voltage into the switcher output. Under light load conditions with power-save enabled, this can force V_{OUT} to slowly rise and reach the over-voltage threshold, resulting in a hard shutdown. Smart power-save prevents this condition. When the FB voltage exceeds 10% above nominal (exceeds 550mV), the device immediately disables power-save and DL drives high to turn on the low-side MOSFET. This draws current from V_{OUT} through the inductor and causes V_{OUT} to fall. When V_{FB} drops back to the 500mV trip point, a normal T_{ON} switching cycle begins. This method prevents a hard OVP shutdown and cycles energy from V_{OUT} back to V_{IN} . It also minimizes operating power by avoiding forced conduction mode operation. Figure 7 shows typical waveforms for the Smart Power-save feature.

Applications Information (continued)

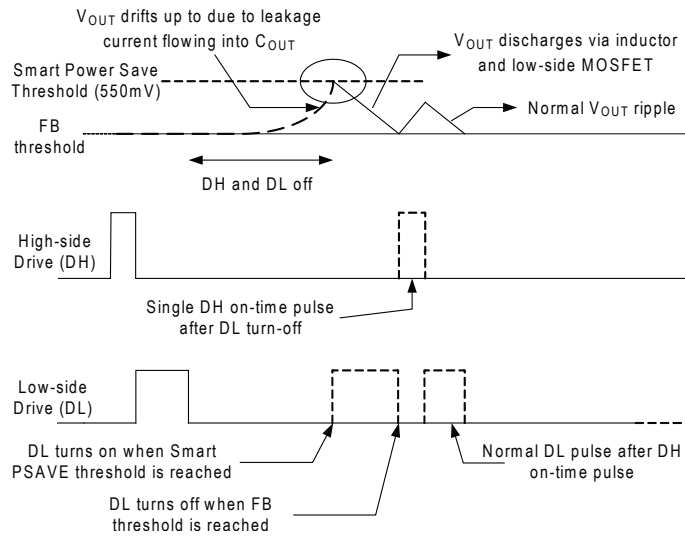

Figure 7 — Smart Power-Save

SmartDrive™

For each DH pulse, the DH driver initially turns on the high-side MOSFET at a slower speed, allowing a softer, smooth turn-off of the low-side diode. Once the diode is off and the LX voltage has risen 0.5V above PGND, the SmartDrive circuit automatically drives the high-side MOSFET on at a rapid rate. This technique reduces switching noise while maintaining high efficiency, reducing the need for snubbers or series resistors in the gate drive.

Enable Input for Switching Regulator

The EN input is a logic level input. When EN is low (grounded), the switching regulator is off and in its lowest power state. When EN is low and VDDA is above the VDDA UVLO threshold, the output of the switching regulator soft-discharges into the VOUT pin through an internal 15Ω resistor. When EN is a logic high ($\geq 1V$) the switching regulator is enabled.

The EN input has internal resistors — 2MΩ pullup to VDDA, and a 1MΩ pulldown to AGND. These resistors will normally cause the EN voltage to be near the logic high trip point as VDDA reaches the VDDA UVLO threshold. To prevent undesired toggling of EN and erratic startup performance, the EN pin should not be allowed to float as open-circuit.

Note that the LDO enable pin (ENL) can also disable the switching regulator through the V_{IN} UVLO function. Refer to the ENL Pin and V_{IN} UVLO section.

Current Limit Protection

The SC418 features programmable current limiting, which is accomplished using the $R_{DS(ON)}$ of the lower MOSFET for current sensing. The current limit is set by R_{ILIM} resistor which connects from the ILIM pin to the drain of the low-side MOSFET. When the low-side MOSFET is on, an internal 10μA current flows from the ILIM pin and through the R_{ILIM} resistor, creating a voltage drop across the resistor. While the low-side MOSFET is on, the inductor current flows through it and creates a voltage across the $R_{DS(ON)}$. The voltage across the MOSFET is negative with respect to PGND. If this MOSFET voltage drop exceeds the voltage across R_{ILIM} , the voltage at the ILIM pin will be negative and current limit will activate. The current limit then keeps the low-side MOSFET on and prevents another high-side on-time, until the current in the low-side MOSFET reduces enough to bring the I_{LIM} voltage up to zero. This method regulates the inductor valley current at the level shown by I_{LIM} in Figure 8.

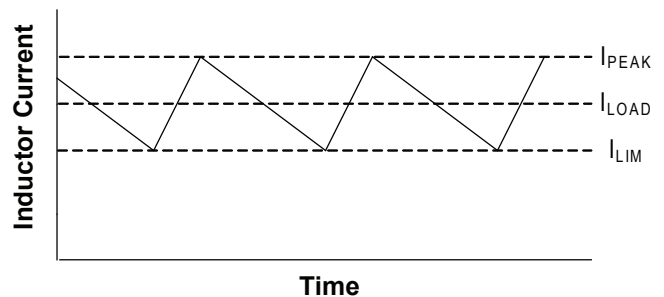

Figure 8 — Valley Current Limit

The current limit schematic with the R_{ILIM} resistor is shown in Figure 9.

Applications Information (continued)

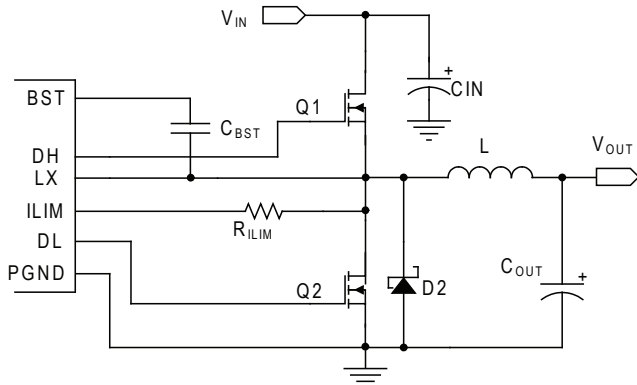

Figure 9 — Valley Current Limit

Setting the valley current limit to 10A results in a peak inductor current of 10A plus peak ripple current. In this situation the average current through the inductor is 10A plus one-half the peak-to-peak ripple current.

The R_{ILIM} value is calculated by the next equation.

$$R_{ILIM} = \frac{R_{DSON} \times I_{LIM}}{10\mu A}$$

The internal 10 μ A current source is temperature compensated at 4100ppm in order to provide tracking with the $R_{DS_{ON}}$.

Note that MOSFET $R_{DS_{(ON)}}$ increases significantly if the VDDP voltage is 3.3V compared to 5.0V. When selecting the R_{ILIM} value, use the $R_{DS_{(ON)}}$ value that corresponds to the VDDP voltage used in the application.

Soft-Start of PWM Regulator

Soft-start is achieved in the PWM regulator by using an internal voltage ramp as the reference for the FB comparator. The voltage ramp is generated using an internal charge pump which drives the reference from zero to 500mV in 1.2mV increments, using an internal 500kHz oscillator. When the ramp voltage reaches 500mV, the ramp is ignored and the FB comparator switches over to a fixed 500mV threshold. During soft-start the output voltage tracks the internal ramp, which limits the start-up inrush current and provides a controlled soft-start profile. Typical soft-start ramp time is 850 μ s.

During soft-start the regulator turns off the low-side MOSFET on any cycle if the inductor current falls to zero, regardless of the psave setting. This prevents negative inductor current, allowing the device to start into a pre-biased output.

Power Good Output

The PGOOD (power good) output is an open-drain output which requires a pull-up resistor. When the voltage at the FB pin is 10% below the nominal voltage, PGOOD is pulled low. It remains low until the FB voltage returns above -8% of nominal. During start-up PGOOD is held low and will not be allowed to transition high until the PGOOD start-up delay time has passed and soft-start is completed (when V_{FB} reaches 500mV). The delay time starting from EN going high is typically 2ms for VDDA = 5V and 1ms for VDDA = 3.3V.

PGOOD will transition low if the FB voltage exceeds +20% of nominal (600mV), which is also the over-voltage shut-down threshold. PGOOD also pulls low if the EN pin is low when VDDA is present.

Output Over-Voltage Protection

OVP (Over-voltage protection) becomes active as soon as the device is enabled. The OVP threshold is set at 500mV + 20% (600mV). When V_{FB} exceeds the OVP threshold, DL latches high and the low-side MOSFET is turned on. DL remains high and the controller remains off until the EN input is toggled or VDDA is cycled. There is a 5 μ s delay built into the OVP detector to prevent false transitions. PGOOD is also low after an OVP event.

Output Under-Voltage Protection

When V_{FB} falls 25% below its nominal voltage (falls to 375mV) for eight consecutive clock cycles, the switcher is shut off and the DH and DL drives are pulled low to tri-state the MOSFETs. The controller stays off until EN is toggled or VDDA is cycled.

VDDA UVLO and POR

The VDDA Under-Voltage Lock-Out (UVLO) circuitry inhibits switching and tri-states the DH/DL drivers until VDDA rises above 2.9V. When VDDA exceeds 2.9V, an internal POR (Power-On Reset) resets the fault latch and the soft-start counter and then the SC418 begins the soft-start

Applications Information (continued)

cycle. The switcher will shut off if VDDA falls below 2.7V. VDDP does not have ULVO protection.

Note that the VDDA UVLO will not stop MOSFET switching until the VDDA voltage falls to 2.7V. During this time the gate driver voltages will track the VDDA supply. Not all MOSFETs will operate or switch effectively at drive levels of 2.7V. For this reason, it is not recommended to rely on VDDA UVLO to shutdown the switcher unless the MOSFETs are capable of operating with 2.7V drive.

LDO Regulator

The LDO output is programmable from 0.75V to 5.25V using external resistors. The feedback pin (FBL) for the LDO is regulated to 750mV. The LDO enable pin (ENL) provides independent control. The LDO voltage can be used to provide the bias voltage for the switching regulator. When a separate source is used as the bias supply, the LDO can be programmed to provide a different voltage. The external resistor connections are shown in Figure 10.

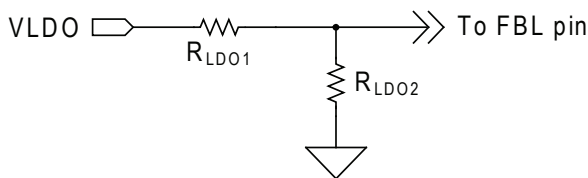

Figure 10 — VLDO Resistor Divider

The LDO output voltage is set by the following equation.

$$VLDO = 750\text{mV} \times \left(1 + \frac{R_{LD01}}{R_{LD02}}\right)$$

A minimum capacitance of 1 μ F referenced to AGND is normally required at the output of the LDO for stability. If the LDO is providing bias power to the device, then a minimum 0.1 μ F capacitor referenced to AGND is required, along with a minimum 1 μ F capacitor referenced to PGND to filter the gate drive pulses. Refer to the PCB Layout Guidelines section.

ENL Pin and VIN UVLO

The ENL pin also acts as the V_{IN} under-voltage lockout for the switcher. The V_{IN} UVLO voltage is programmable via a resistor divider at the VIN, ENL and AGND pins. The V_{IN} UVLO function has a typical threshold of 2.6V on the V_{IN} rising edge. The falling edge threshold is 2.4V.

Timing is important when driving ENL with logic and not implementing V_{IN} UVLO. The ENL pin must transition from high to low within 2 switching cycles to avoid the PWM output turning off. If ENL goes below the V_{IN} UVLO threshold and stays above 1V, then the switcher will turn off but the LDO will remain on.

Note that it is possible to operate the switcher with the LDO disabled, but the ENL pin must be below the logic low threshold (0.4V maximum), otherwise the V_{IN} UVLO function will disable the switcher.

The table below summarizes the function of the ENL and EN pins, with respect to the rising edge of ENL.

| EN | ENL | LDO status | Switcher status |
|------|--------------|------------|-----------------|
| low | low, < 0.4V | off | off |
| high | low, < 0.4V | off | on |
| low | high, < 2.6V | on | off |
| high | high, < 2.6V | on | off |
| low | high, > 2.6V | on | off |
| high | high, > 2.6V | on | on |

Figure 11 shows the ENL voltage thresholds and their effect on LDO and Switcher operation.

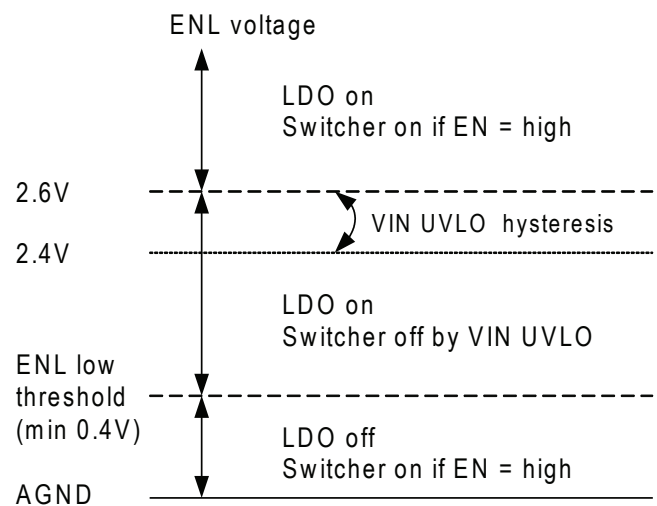

Figure 11 — ENL Thresholds

Applications Information (continued)

ENL Logic Control of PWM Operation

When the ENL input exceeds the V_{IN} UVLO threshold of 2.6V, internal logic checks the PGOOD signal. If PGOOD is high, the switcher is already running and the LDO will start without affecting the switcher. If PGOOD is low, the device disables PWM switching until the LDO output has reached 90% of its final value. This delay prevents the additional current needed by the DH and DL gate drives from overloading the LDO at start-up.

In some cases it is desirable to use the V_{IN} UVLO feature for the switcher without using the LDO. This can be done by connecting the FBL pin directly to VDDA. This disables the LDO, allowing the ENL pin to be used only for V_{IN} UVLO for the switcher.

LDO Start-up

Before LDO start-up, the device checks the status of the following signals to ensure proper operation can be maintained.

1. ENL pin
2. VLDO output
3. V_{IN} input voltage

When the ENL pin is high and V_{IN} is available, the LDO will begin start-up. During the initial phase, when VLDO is near zero, the LDO initiates a current-limited start-up (typically 115mA) to charge the output capacitor. When V_{LDO} has reached 90% of the final value (as sensed at the FBL pin), the LDO current limit is increased to 200mA and the LDO output is quickly driven to the nominal value. The LDO start-up is shown in Figure 12.

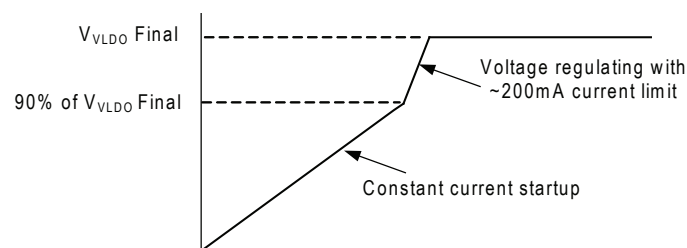

Figure 12 — LDO Start-Up

LDO Switch-Over Operation

The SC418 includes a switch-over function for the LDO. The switch-over function is designed to increase efficiency by using the more efficient DC-DC converter to power the LDO output, avoiding the less efficient LDO regulator when possible. The switch-over function connects the VLDO pin directly to the VOUT pin through an internal switch. When the switch-over is complete the LDO is turned off, which reduces operating power loss. If the LDO output is used to bias the SC418, then after switch-over the device is self-powered from the switching regulator with the LDO turned off.

After the switcher completes soft-start, the switch-over logic waits for 32 switching cycles before it starts the switch-over. There are two methods of completing the switch-over of V_{LDO} to V_{OUT} .

In the first method, the LDO is already in regulation when the DC-DC converter is enabled. As soon as the PGOOD output goes high, the 32 cycle count is started. The voltages at the VLDO and VOUT pins are then compared; if the two voltages are within $\pm 300\text{mV}$ of each other, the VLDO pin connects to the VOUT pin using an internal switch, and the LDO is turned off.

In the second method, the DC-DC converter is already running and the LDO is enabled. In this case the 32 cycle count is started as soon as the LDO reaches 90% of its final value. At this time, the VLDO and VOUT pins are compared, and if within $\pm 300\text{mV}$ the switch-over occurs and the LDO is turned off.

Switch-over Limitations on VOUT and VLDO

Because the internal switch-over circuit always compares the VOUT and VLDO pins at start-up, there are limitations on permissible combinations of VOUT and VLDO. Consider the case where VOUT is programmed to 1.5V and VLDO is programmed to 1.8V. After start-up, the device would connect VOUT to VLDO and disable the LDO, since the two voltage are within the $\pm 300\text{mV}$ switch-over window. To avoid unwanted switch-over, the minimum difference between VOUT and VLDO should be $\pm 500\text{mV}$.

Applications Information (continued)

It is not recommended to use the switch-over feature for an output voltage of 3.3V or less since this does not provide sufficient voltage for the gate-source drive to the internal p-channel switch-over MOSFET.

It is not recommended to use the switch-over feature in cases where the device is powered from 3.3V which is initially derived from the LDO. If the switch-over was used, then the 3.3V switcher output would pass through the switch-over MOSFET to power the VDDA/VDDP pins. The $R_{DS(ON)}$ of the switch-over device, typically 2.2 ohms at 3.3V, will cause a voltage drop across the device. The VDDA/VDDP pins would be typically 200mV or more below the 3.3V rail, due to the IR drop caused by the VDDA/VDDP current. If this voltage drop becomes large enough, the VDDA voltage will drop near the VDDA UVLO threshold, causing the device to shutdown.

Switch-over MOSFET Parasitic Diodes

The switch-over MOSFET contains parasitic diodes that are inherent to its construction, as shown in Figure 13.

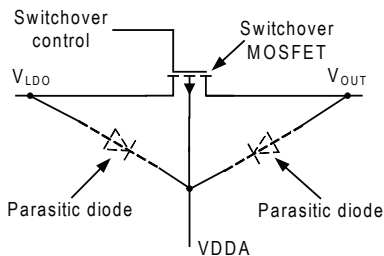

Figure 13— Switch-over MOSFET Parasitic Diodes

It is important to prevent forward bias of these diodes. The following two conditions must be satisfied in order for the parasitic diodes to stay off.

- $V_{DDA} \geq V_{LDO}$
- $V_{DDA} \geq V_{OUT}$

If either V_{LDO} or V_{OUT} is higher than VDDA, then the respective diode will turn on and the SC418 operating current will then flow through this diode. This has the potential of damaging the device.

Note that if the VDDA supply is 3.3V then both the LDO and switching regulator outputs are limited to 3.3V maximum. Trying to obtain higher voltages such as 5V

will forward-bias one of the parasitic diodes and could damage the device.

Using the Internal LDO to Bias the SC418

The following steps must be followed when using the internal LDO to bias the device.

- Connect VDDA and VDDP to VLDO before enabling the LDO.
- Any external load on VLDO should not exceed 40mA until the LDO voltage has reached 90% of final value.

When the switch-over feature is used and the VDDA/VDDP power comes from V_{OUT} , the EN and ENL inputs must be used carefully. Do not connect the EN pin directly to VDDA or another supply voltage. If this is done, driving the ENL pin low (to AGND) will turn off the LDO and the LDO switch-over MOSFET, but the switcher will continue operating. V_{OUT} will feed into the LDO output and the VDDA/VDDP supplies through the internal parasitic diode. This can potentially damage the device, and also prevents the switcher from shutting off until the VDDA supply drops below the VDDA UVLO threshold. For these applications a dedicated logic signal is required to drive EN low and disable the switcher. This signal can be combined with the ENL signal if needed.

Design Procedure

When designing a switch mode supply the input voltage range, load current, switching frequency, and inductor ripple current must be specified.

The maximum input voltage (V_{INMAX}) is the highest specified input voltage. The minimum input voltage (V_{INMIN}) is determined by the lowest input voltage after evaluating the voltage drops due to connectors, fuses, switches, and PCB traces.

The following parameters define the design.

- Nominal output voltage (V_{OUT})
- Static or DC output tolerance
- Transient response
- Maximum load current (I_{OUT})

There are two values of load current to evaluate — continuous load current and peak load current. Continuous

Applications Information (continued)

load current relates to thermal stresses which drive the selection of the inductor and input capacitors. Peak load current determines instantaneous component stresses and filtering requirements such as inductor saturation, output capacitors, and design of the current limit circuit.

The following values are used in this design.

- $V_{IN} = 12V \pm 10\%$
- $V_{OUT} = 1.05V \pm 4\%$
- $f_{SW} = 250kHz$
- Load = 10A maximum

Frequency Selection

Selection of the switching frequency requires making a trade-off between the size and cost of the external filter components (inductor and output capacitor) and the power conversion efficiency.

The desired switching frequency is 250kHz.

A resistor, R_{TON} is used to program the on-time (indirectly setting the frequency) using the following equation.

$$R_{TON} = \frac{(T_{ON} - 10ns) \times V_{IN}}{25pF \times V_{OUT}}$$

To select R_{TON} , use the maximum value for V_{IN} and for T_{ON} use the value associated with maximum V_{IN} .

$$T_{ON} = \frac{V_{OUT}}{V_{INMAX} \times f_{SW}}$$

$$T_{ON} = 318 \text{ ns at } 13.2V_{IN}, 1.05V_{OUT}, 250kHz$$

Substituting for R_{TON} results in the following solution.

$$R_{TON} = 154.9k\Omega, \text{ use } R_{TON} = 154k\Omega$$

Inductor Selection

In order to determine the inductance, the ripple current must first be defined. Low inductor values result in smaller size but create higher ripple current which can reduce efficiency. Higher inductor values will reduce the ripple current/voltage and for a given DC resistance are more efficient. However, larger inductance translates directly into larger packages and higher cost. Cost, size, output ripple, and efficiency are all used in the selection process.

The ripple current will also set the boundary for power-save operation. The switching will typically enter power-save mode when the load current decreases to 1/2 of the ripple current. For example, if ripple current is 4A then Power-save operation will typically start for loads less than 2A. If ripple current is set at 40% of maximum load current, then power-save will start for loads less than 20% of maximum current.

The inductor value is typically selected to provide a ripple current that is between 25% to 50% of the maximum load current. This provides an optimal trade-off between cost, efficiency, and transient performance.

During the DH on-time, voltage across the inductor is $(V_{IN} - V_{OUT})$. The following equation for determining inductance is shown.

$$L = \frac{(V_{IN} - V_{OUT}) \times T_{ON}}{I_{RIPPLE}}$$

In this example the inductor ripple current is set equal to 50% of the maximum load current. Thus ripple current will be 50% x 10A or 5A.

To find the minimum inductance needed, use the V_{IN} and T_{ON} values that correspond to V_{INMAX} .

$$L = \frac{(13.2 - 1.05) \times 318ns}{5A} = 0.77\mu H$$

A slightly larger value of 0.88 μ H is selected. This will decrease the maximum I_{RIPPLE} to 4.4A.

Note that the inductor must be rated for the maximum DC load current plus 1/2 of the ripple current.

The ripple current under minimum V_{IN} conditions is also checked using the following equations.

$$T_{ON_VINMIN} = \frac{25pF \times R_{TON} \times V_{OUT}}{V_{INMIN}} + 10ns = 384ns$$

$$I_{RIPPLE} = \frac{(V_{IN} - V_{OUT}) \times T_{ON}}{L}$$

$$I_{RIPPLE_VINMIN} = \frac{(10.8 - 1.05) \times 384ns}{088\mu H} = 4.25A$$

Applications Information (continued)

Capacitor Selection

The output capacitors are chosen based on required ESR and capacitance. The maximum ESR requirement is controlled by the output ripple requirement and the DC tolerance. The output voltage has a DC value that is equal to the valley of the output ripple plus 1/2 of the peak-to-peak ripple. Change in the output ripple voltage will lead to a change in DC voltage at the output.

The design goal is for the output voltage regulation to be $\pm 4\%$ under static conditions. The internal 500mV reference tolerance is 1%. Allowing 1% tolerance from the FB resistor divider, this allows 2% tolerance due to V_{OUT} ripple. Since this 2% error comes from 1/2 of the ripple voltage, the allowable ripple is 4%, or 42mV for a 1.05V output.

The maximum ripple current of 4.4A creates a ripple voltage across the ESR. The maximum ESR value allowed is shown by the following equations.

$$ESR_{MAX} = \frac{V_{RIPPLE}}{I_{RIPPLEMAX}} = \frac{42mV}{4.4A}$$

$$ESR_{MAX} = 9.5 \text{ m}\Omega$$

The output capacitance is chosen to meet transient requirements. A worst-case load release, from maximum load to no load at the exact moment when inductor current is at the peak, determines the required capacitance. If the load release is instantaneous (load changes from maximum to zero in $< 1\mu s$), the output capacitor must absorb all the inductor's stored energy. This will cause a peak voltage on the capacitor according to the following equation.

$$C_{OUT_{MIN}} = \frac{L \left(I_{OUT} + \frac{1}{2} \times I_{RIPPLEMAX} \right)^2}{(V_{PEAK})^2 - (V_{OUT})^2}$$

Assuming a peak voltage V_{PEAK} of 1.150 (100mV rise upon load release), and a 10A load release, the required capacitance is shown by the next equation.

$$C_{OUT_{MIN}} = \frac{0.88\mu H \left(10 + \frac{1}{2} \times 4.4 \right)^2}{(1.15)^2 - (1.05)^2}$$

$$C_{OUT_{MIN}} = 595\mu F$$

If the load release is relatively slow, the output capacitance can be reduced. At heavy loads during normal switching, when the FB pin is above the 500mV reference, the DL output is high and the low-side MOSFET is on. During this time, the voltage across the inductor is approximately $-V_{OUT}$. This causes a down-slope or falling di/dt in the inductor. If the load di/dt is not faster than the $-di/dt$ in the inductor, then the inductor current will tend to track the falling load current. This will reduce the excess inductive energy that must be absorbed by the output capacitor, therefore a smaller capacitance can be used.

The following can be used to calculate the needed capacitance for a given di_{LOAD}/dt . Peak inductor current is shown by the next equation.

$$I_{L_{PK}} = I_{MAX} + 1/2 \times I_{RIPPLEMAX}$$

$$I_{L_{PK}} = 10 + 1/2 \times 4.4 = 12.2A$$

$$\text{Rate of change of Load Current} = \frac{di_{LOAD}}{dt}$$

$$I_{MAX} = \text{maximum load release} = 10A$$

$$C_{OUT} = I_{L_{PK}} \times \frac{L \times \left(\frac{I_{L_{PK}}}{V_{OUT}} - \frac{I_{MAX}}{di_{LOAD}} \right) \times dt}{2(V_{PK} - V_{OUT})}$$

Example

$$\frac{di_{LOAD}}{dt} = \frac{2.5A}{\mu s}$$

This would cause the output current to move from 10A to zero in $4\mu s$ as shown by the following equation.

$$C_{OUT} = 12.2 \times \frac{0.88\mu H \times \left(\frac{12.2}{1.05} - \frac{10}{2.5} \right) \times 1\mu s}{2(1.15 - 1.05)}$$

$$C_{OUT} = 379\mu F$$

Note that C_{OUT} is much smaller in this example, 379 μF compared to 595 μF based on a worst-case load release. To

Applications Information (continued)

meet the two design criteria of minimum 379 μ F and maximum 9m Ω ESR, select two capacitors rated at 220 μ F and 15m Ω ESR.

It is recommended that an additional small capacitor be placed in parallel with C_{OUT} in order to filter high frequency switching noise.

Stability Considerations

Unstable operation is possible with adaptive on-time controllers, and usually takes the form of double-pulsing or ESR loop instability.

Double-pulsing occurs due to switching noise seen at the FB input or because the FB ripple voltage is too low. This causes the FB comparator to trigger prematurely after the 250ns minimum off-time has expired. In extreme cases the noise can cause three or more successive on-times. Double-pulsing will result in higher ripple voltage at the output, but in most applications it will not affect operation. This form of instability can usually be avoided by providing the FB pin with a smooth, clean ripple signal that is at least 10mVp-p, which may dictate the need to increase the ESR of the output capacitors. It is also imperative to provide a proper PCB layout as discussed in the Layout Guidelines section.

Another way to eliminate doubling-pulsing is to add a small capacitor across the upper feedback resistor, as shown in Figure 14. This capacitor should be left unpopulated unless it can be confirmed that double-pulsing exists. Adding the C_{TOP} capacitor will couple more ripple into FB to help eliminate the problem. An optional connection on the PCB should be available for this capacitor.

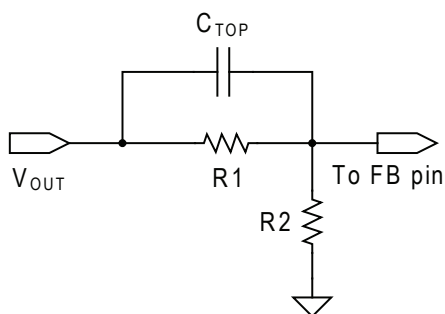

Figure 14 — Capacitor Coupling to FB Pin

ESR loop instability is caused by insufficient ESR. The details of this stability issue are discussed in the ESR Requirements section. The best method for checking stability is to apply a zero-to-full load transient and observe the output voltage ripple envelope for overshoot and ringing. Ringing for more than one cycle after the initial step is an indication that the ESR should be increased.

One simple way to solve this problem is to add trace resistance in the high current output path. A side effect of adding trace resistance is decreased load regulation.

ESR Requirements

A minimum ESR is required for two reasons. One reason is to generate enough output ripple voltage to provide 10mVp-p at the FB pin (after the resistor divider) to avoid double-pulsing.

The second reason is to prevent instability due to insufficient ESR. The on-time control regulates the valley of the output ripple voltage. This ripple voltage is the sum of the two voltages. One is the ripple generated by the ESR, the other is the ripple due to capacitive charging and discharging during the switching cycle. For most applications the minimum ESR ripple voltage is dominated by the output capacitors, typically SP or POSCAP devices. For stability the ESR zero of the output capacitor should be lower than approximately one-third the switching frequency. The formula for minimum ESR is shown by the following equation.

$$ESR_{MIN} = \frac{3}{2 \times \pi \times C_{OUT} \times f_{sw}}$$

Using Ceramic Output Capacitors

When applications use ceramic output capacitors, the ESR is normally too small to meet the previously stated ESR criteria. In these applications it is necessary to add a small virtual ESR network composed of two capacitors and one resistor, as shown in Figure 15.

Applications Information (continued)

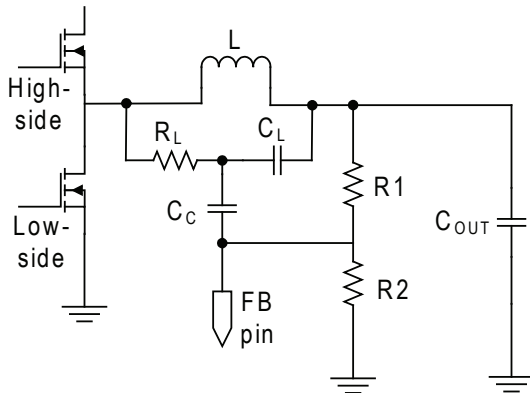

Figure 15 — Virtual ESR Ramp Current

This network creates a ramp voltage across C_L analogous to the ramp voltage generated across the ESR of a standard capacitor. This ramp is then capacitively coupled into the FB pin via capacitor C_C .

Dropout Performance

The output voltage adjust range for continuous-conduction operation is limited by the fixed 250ns (typical) minimum off-time of the one-shot. When working with low input voltages, the duty-factor limit must be calculated using worst-case values for on and off times.

The duty-factor limitation is shown by the following equation.

$$\text{DUTY} = \frac{T_{\text{ON(MIN)}}}{T_{\text{ON(MIN)}} + T_{\text{OFF(MAX)}}$$

The inductor resistance and MOSFET on-state voltage drops must be included when performing worst-case dropout duty-factor calculations.

System DC Accuracy (V_{OUT} Controller)

Three factors affect V_{OUT} accuracy: the trip point of the FB error comparator, the ripple voltage variation with line and load, and the external resistor tolerance. The error comparator offset is trimmed so that under static conditions it trips when the feedback pin is 500mV, $\pm 1\%$.

The on-time pulse from the SC418 in the design example is calculated to give a pseudo-fixed frequency of 250kHz. Some frequency variation with line and load is expected. This variation changes the output ripple voltage. Because adaptive on-time converters regulate to the valley of the output ripple, $\frac{1}{2}$ of the output ripple appears as a DC regulation error. For example, if the output ripple is 50mV with $V_{\text{IN}} = 6$ volts, then the measured DC output will be 25mV above the comparator trip point. If the ripple increases to 80mV with $V_{\text{IN}} = 25$ V, then the measured DC output will be 40mV above the comparator trip. The best way to minimize this effect is to minimize the output ripple.

To compensate for valley regulation, it may be desirable to use passive droop. Take the feedback directly from the output side of the inductor and place a small amount of trace resistance between the inductor and output capacitor. This trace resistance should be optimized so that at full load the output droops to near the lower regulation limit. Passive droop minimizes the required output capacitance because the voltage excursions due to load steps are reduced as seen at the load.

The use of 1% feedback resistors contributes up to 1% error. If tighter DC accuracy is required, 0.1% resistors should be used.

The output inductor value may change with current. This will change the output ripple and therefore will have a minor effect on the DC output voltage. The output ESR also affects the output ripple and thus has a minor effect on the DC output voltage.

Switching Frequency Variations

The switching frequency will vary depending on line and load conditions. The line variations are a result of fixed propagation delays in the on-time one-shot, as well as unavoidable delays in the external MOSFET switching. As V_{IN} increases, these factors make the actual DH on-time slightly longer than the ideal on-time. The net effect is that frequency tends to fall slightly with increasing input voltage.

The switching frequency also varies with load current as a result of the power losses in the MOSFETs and the induc-