



Chipsmall Limited consists of a professional team with an average of over 10 year of expertise in the distribution of electronic components. Based in Hongkong, we have already established firm and mutual-benefit business relationships with customers from,Europe,America and south Asia,supplying obsolete and hard-to-find components to meet their specific needs.

With the principle of “Quality Parts,Customers Priority,Honest Operation,and Considerate Service”,our business mainly focus on the distribution of electronic components. Line cards we deal with include Microchip,ALPS,ROHM,Xilinx,Pulse,ON,Everlight and Freescale. Main products comprise IC,Modules,Potentiometer,IC Socket,Relay,Connector.Our parts cover such applications as commercial,industrial, and automotives areas.

We are looking forward to setting up business relationship with you and hope to provide you with the best service and solution. Let us make a better world for our industry!



## Contact us

Tel: +86-755-8981 8866 Fax: +86-755-8427 6832

Email & Skype: info@chipsmall.com Web: www.chipsmall.com

Address: A1208, Overseas Decoration Building, #122 Zhenhua RD., Futian, Shenzhen, China



### POWER MANAGEMENT

#### Features

- Input Voltage as low as 1.45V
- 500mV dropout @ 3A
- Adjustable output from 0.5V
- Over current and over temperature protection
- Enable pin
- 10µA quiescent current in shutdown
- Full industrial temperature range
- Available in SOIC-8-EDP Lead-free package, fully WEEE and RoHS compliant and halogen-free

#### Applications

- Telecom/Networking cards
- Motherboards/Peripheral cards
- Industrial applications
- Wireless infrastructure
- Set top boxes
- Medical equipment
- Notebook computers
- Battery powered systems

#### Description

The SC4216H is a high performance positive voltage regulator designed for use in applications requiring very low input voltage and very low dropout voltage at up to 3 amperes. It operates with a  $V_{in}$  as low as 1.45V, with output voltage programmable as low as 0.5V. The SC4216H features ultra low dropout, ideal for applications where  $V_{out}$  is very close to  $V_{in}$ . Additionally, the SC4216H has an enable pin to further reduce power dissipation while shutdown. The SC4216H provides excellent regulation over variations in line, load and temperature.

The SC4216H is available in the SOIC-8-EDP (Exposed Die Pad) package. The output voltage can be set via an external divider or to a fixed setting of 0.5V depending on how the FB pin is configured.

### Typical Application Circuit

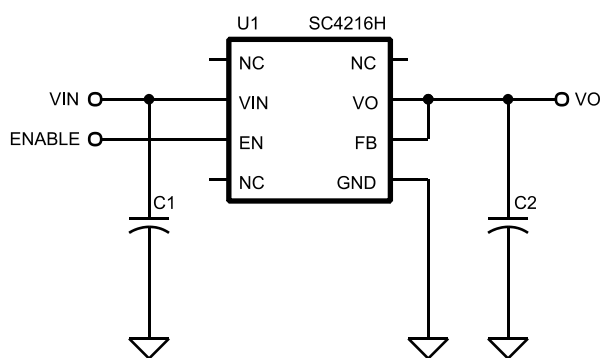

$$V_O = 0.5V$$

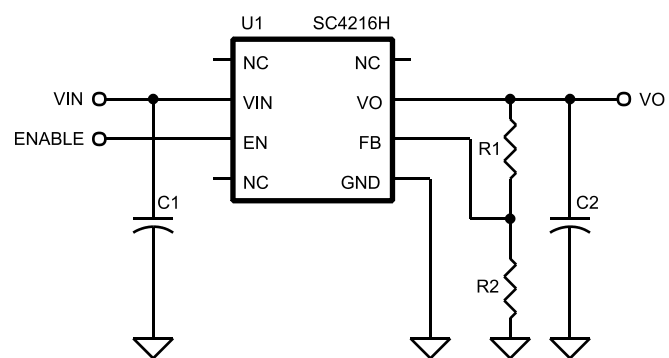

$$V_O = \frac{0.5(R_1 + R_2)}{R_2} \text{ (Volts)}$$

## Pin Configuration

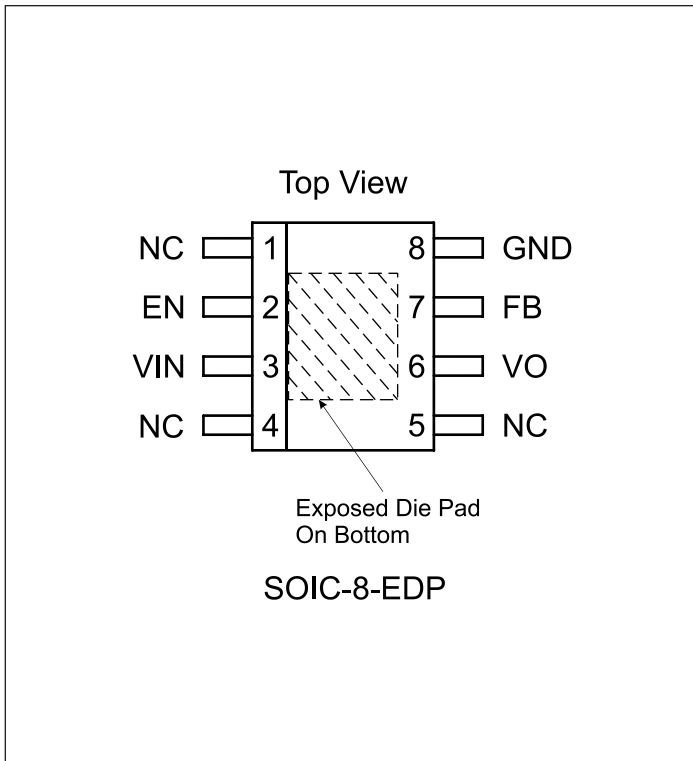

## Ordering Information

Device	Package
SC4216HSETRT <sup>(1)(2)</sup>	SOIC-8-EDP
SC4216HEVB	Evaluation Board

Notes:

- (1) Available in tape and reel only. A reel contains 2,500 devices.
- (2) Available in lead-free package only. Device is WEEE and RoHS compliant and halogen-free.

## Marking Information

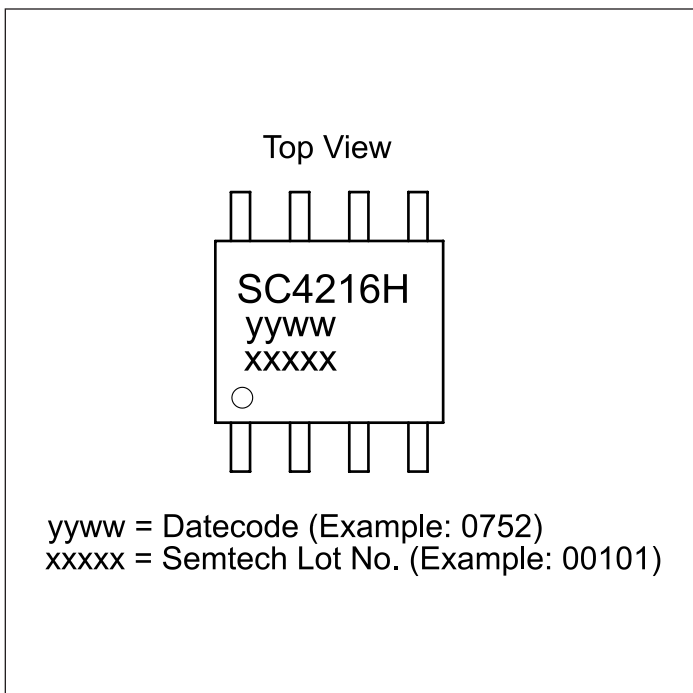

## Absolute Maximum Ratings

VIN, EN, VO, FB to GND (V) .....	-0.3 to +7.0
Power Dissipation.....	Internally Limited
ESD Protection Level <sup>(1)</sup> (kV) .....	2

## Recommended Operating Conditions

VIN (V) .....	$1.45 \leq V_{IN} \leq 5.5$
Ambient Temperature Range (°C).....	$-40 \leq T_A \leq +105$
Junction Temperature Range (°C).....	$-40 \leq T_J \leq +125$
Maximum Output Current (A) .....	3

## Thermal Information

Thermal Resistance, Junction to Ambient <sup>(2)</sup> (°C/W) ....	36
Thermal Resistance, Junction to Case <sup>(2)</sup> (°C/W).....	5.5
Maximum Junction Temperature (°C) .....	+150
Storage Temperature Range (°C) .....	-65 to +150
Peak IR Reflow Temperature (10s to 30s) (°C) .....	+260

Exceeding the above specifications may result in permanent damage to the device or device malfunction. Operation outside of the parameters specified in the Electrical Characteristics section is not recommended.

### NOTES:

- (1) Tested according to JEDEC standard JESD22-A114-B.
- (2) Calculated from package in still air, mounted to 3 x 4.5 (in.), 4 layer FR4 PCB with thermal vias under the exposed pad per JESD51 standards.

## Electrical Characteristics

Unless specified:  $V_{EN} = V_{IN}$ ,  $V_{FB} = V_O$ ,  $V_{IN} = 1.45V$  to  $5.5V$ ,  $I_O = 10\mu A$  to  $3A$ ,  $T_A = 25^\circ C$ .  
 Values in bold apply over the full operating temperature range.

Parameter	Symbol	Conditions	Min	Typ	Max	Units
<b>VIN</b>						
Quiescent Current	$I_Q$	$V_{IN} = 3.3V, I_O = 0A$			<b>3</b>	mA
		$V_{IN} = 5.5V, V_{EN} = 0V$		10	<b>50</b>	$\mu A$
<b>VO</b>						
Output Voltage <sup>(1)</sup> (Fixed Voltage, $V_{FB} = V_O$ )	$V_O$	$V_{IN} = V_O + 0.5V, I_O = 10mA$	-2%	$V_O$	+2%	V
		$1.45V \leq V_{IN} \leq 5.5V, I_O = 10mA$	<b>-3%</b>		<b>+3%</b>	
Line Regulation <sup>(1)</sup>	$REG_{(LINE)}$	$I_O = 10mA$		0.2	<b>0.4</b>	%/V
Load Regulation <sup>(1)</sup>	$REG_{(LOAD)}$	$10mA \leq I_O \leq 3A, 1.6V \leq V_{IN} \leq 5.5V$		0.25	<b>1.0</b>	%
Dropout Voltage <sup>(1)(2)</sup>	$V_{DO}$	$I_O = 500mA$		75	150	mV
					<b>200</b>	
		$I_O = 1A$		150	250	
					<b>300</b>	

**Electrical Characteristics (continued)**

Parameter	Symbol	Conditions	Min	Typ	Max	Units
Dropout Voltage <sup>(1)(2)</sup>	$V_{DO}$	$I_o = 1.5A$		250	350	mV
					<b>400</b>	
		$I_o = 2A$		300	400	
					<b>500</b>	
		$I_o = 2.5A$		350	450	
					<b>600</b>	
		$I_o = 3A$		450	550	
					<b>700</b>	
		$I_o = 3A, 1.6V \leq V_{IN} \leq 5.5V$		400	500	
					<b>650</b>	
Minimum Load Current <sup>(3)(4)</sup>	$I_o$				<b>10</b>	$\mu A$
Current Limit <sup>(4)</sup>	$I_{CL}$		<b>3.5</b>	4.5	<b>5.0</b>	A
<b>Feedback</b>						
Reference Voltage <sup>(1)</sup>	$V_{REF}$	$V_{IN} = 3.3V, V_{FB} = V_{OUT}, I_o = 10mA$	0.495	0.5	0.505	V
			<b>0.490</b>		<b>0.510</b>	
Feedback Pin Current <sup>(4)</sup>	$I_{ADJ}$	$V_{FB} = V_{REF}$		80	<b>200</b>	nA
<b>EN</b>						
Enable Pin Current	$I_{EN}$	$V_{EN} = 0V, V_{IN} = 3.3V$		1.5	<b>10</b>	$\mu A$
Enable Pin Threshold	$V_{IH}$	$V_{IN} = 3.3V$	<b>1.6</b>			V
	$V_{IL}$				<b>0.4</b>	
<b>Over Temperature Protection</b>						
High Trip Level	$T_{HI}$			160		$^{\circ}C$
Hysteresis	$T_{HYST}$			10		$^{\circ}C$

**Notes:**

(1) Low duty cycle pulse testing with Kelvin connections required.

(2)  $V_{DO} = V_{IN} - V_o$  when  $V_o$  decreases by 1.5% of its nominal output voltage with  $V_{IN} = V_o + 0.8V$ .

(3) Required to maintain regulation. Voltage set resistors R1 and R2 are usually utilized to meet this requirement.

(4) Guaranteed by design.

## Typical Characteristics

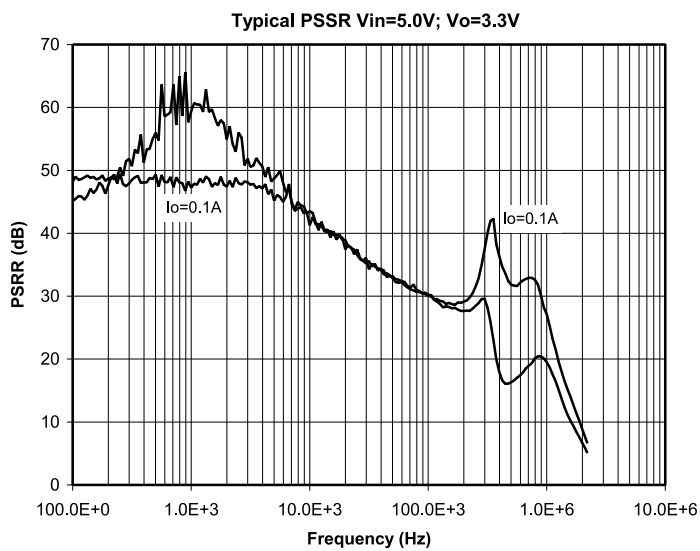
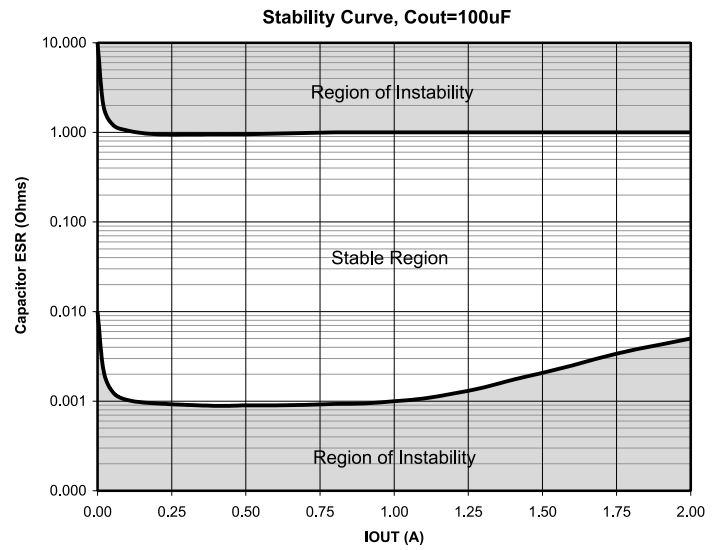
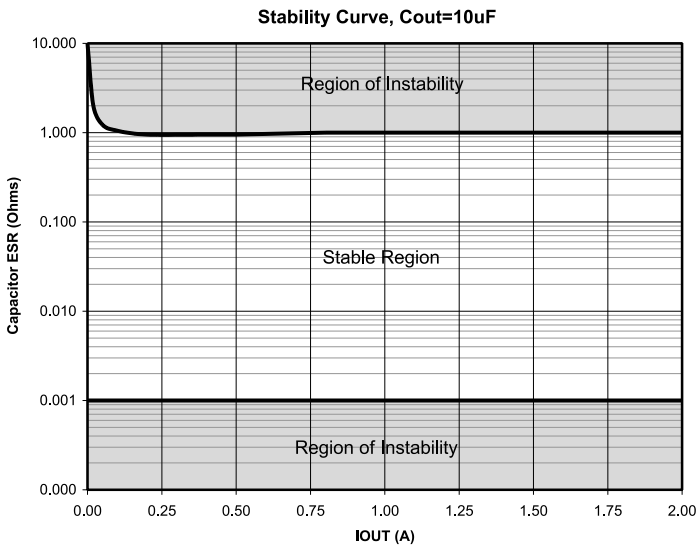

## Pin Descriptions

Pin #	Pin Name	Pin Function
2	EN	Enable Input. Pulling this pin below 0.4V turns the regulator off, reducing the quiescent current to a fraction of its operating value. The device will be enabled if this pin is left open. Connect to VIN if not being used.
3	VIN	Input voltage. For regulation at full load, the input to this pin must be between (VO+ 0.5V) and 5.5V. Minimum VIN = 1.45V. A large bulk capacitance should be placed closely to this pin to ensure that the input supply does not sag below 1.4V. Also a minimum of 4.7uF ceramic capacitor should be placed directly at this pin.
6	VO	The pin is the power output of the device. A minimum of 10uF capacitor should be placed directly at this pin.
7	FB	When this pin is connected to the Vo pin, the output voltage will be set at 0.5V. If external feedback resistors are used, the output voltage will be determined by the resistor ratio (See Application Circuits on page 1)
8	GND	Reference ground. The GND pin and the exposed die pad must be connected together at the IC pin.
1, 4, 5	NC	No Connection
	THERMAL PAD	Pad for heatsinking purposes. Connect to ground plane using multiple vias.

## Block Diagram

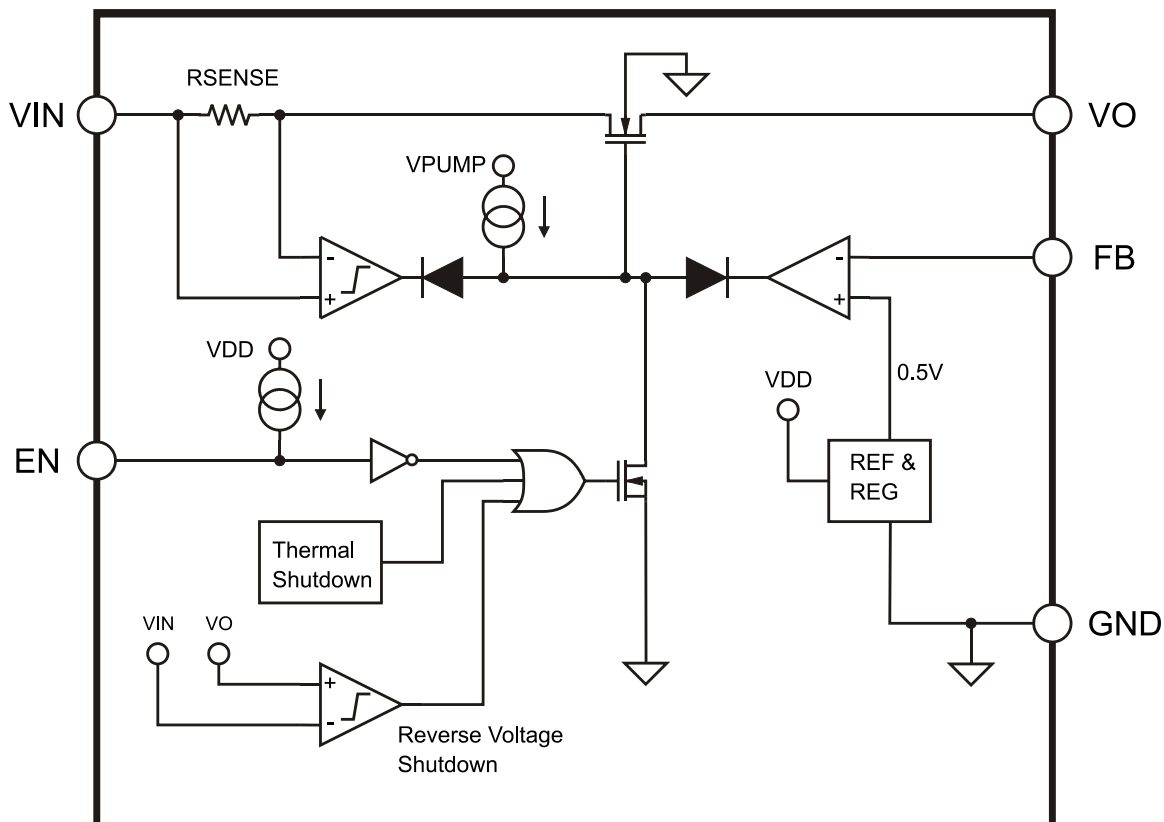

## Applications Information (continued)

### Introduction

The SC4216H is intended for applications where high current capability and very low dropout voltage are required. It provides a very simple, low cost solution that uses very little PCB real estate. Additional features include an enable pin to allow for a very low power consumption standby mode, and a fully adjustable output.

The SC4216H is especially recommended for applications where  $V_O > 3.8V$ , for lower output voltage requirements the SC4216 can be considered.

### Component Selection

**Input capacitor:** A large bulk capacitance  $\geq 10\mu F/A$  (output load) should be closely placed to the input supply pin of the SC4216H to ensure that  $V_{in}$  does not sag below 1.45V. Also a minimum of 4.7 $\mu F$  ceramic capacitor is recommended to be placed directly next to the  $V_{in}$  pin. This allows for the device being some distance from any bulk capacitance on the rail. Additionally, input droop due to load transients is reduced, improving load transient response. Additional capacitance may be added if required by the application.

**Output capacitor:** A minimum bulk capacitance of  $\geq 10\mu F/A$  (output load), along with a 0.1 $\mu F$  ceramic decoupling capacitor is recommended. Increasing the bulk capacitance will improve the overall transient response. The use of multiple lower value ceramic capacitors in parallel to achieve the desired bulk capacitance will not cause stability issues. Although designed for use with ceramic output capacitors, the SC4216H is extremely tolerant of output capacitor ESR values and thus will also work comfortably with tantalum output capacitors.

**Noise immunity:** In very electrically noisy environments, it is recommended that 0.1 $\mu F$  ceramic capacitors be placed from IN to GND and OUT to GND as close to the device pins as possible.

**Internal voltage selection:** By connecting the FB pin directly to the VO pin, the output voltage will be regulated to the 0.5V internal reference.

**External voltage selection resistors:** The use of 1% resistors, and designing for a current flow  $\geq 10\mu A$  is recommended to ensure a well regulated output (thus  $R_2$

$\leq 50k\Omega$ ). A suitable value for  $R_2$  can be chosen in the range of 1k $\Omega$  to 50k $\Omega$ .  $R_1$  can then be calculated from.

$$R_1 = R_2 \cdot \frac{(V_O - V_{REF})}{V_{REF}}$$

**Enable:** Pulling this pin below 0.4V turns the regulator off, reducing the quiescent current to a fraction of its operating value. A pull up resistor up to 400kOhms should be connected from this pin to the  $V_{in}$  pin in applications where supply voltages of  $V_{in} < 1.9V$  are required. For applications with higher voltages than 1.9V, EN pin could be left open or connected to  $V_{in}$ .

### Thermal Considerations

The power dissipation in the SC4216H is given by:

$$P_D \approx I_O \cdot (V_{IN} - V_O)$$

The allowable power dissipation will be dependant on the thermal impedance achieved in the application. The derating curve below is valid for the thermal impedance specified in the Thermal Information section on page 3.

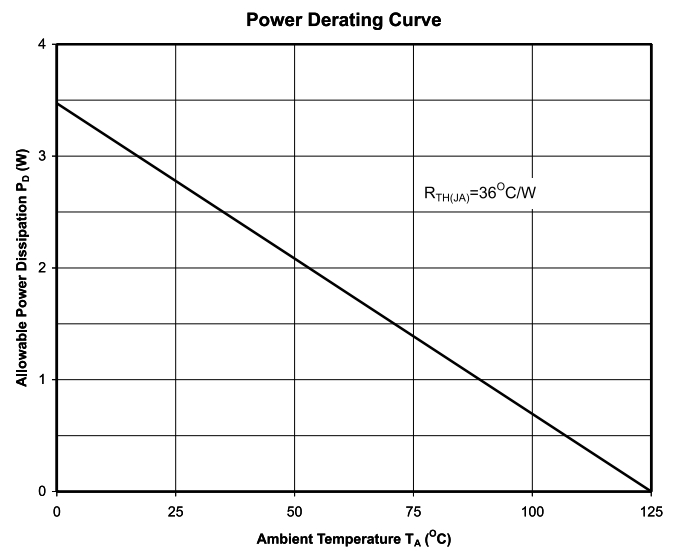



Outline Drawing — SOIC-8-EDP-2

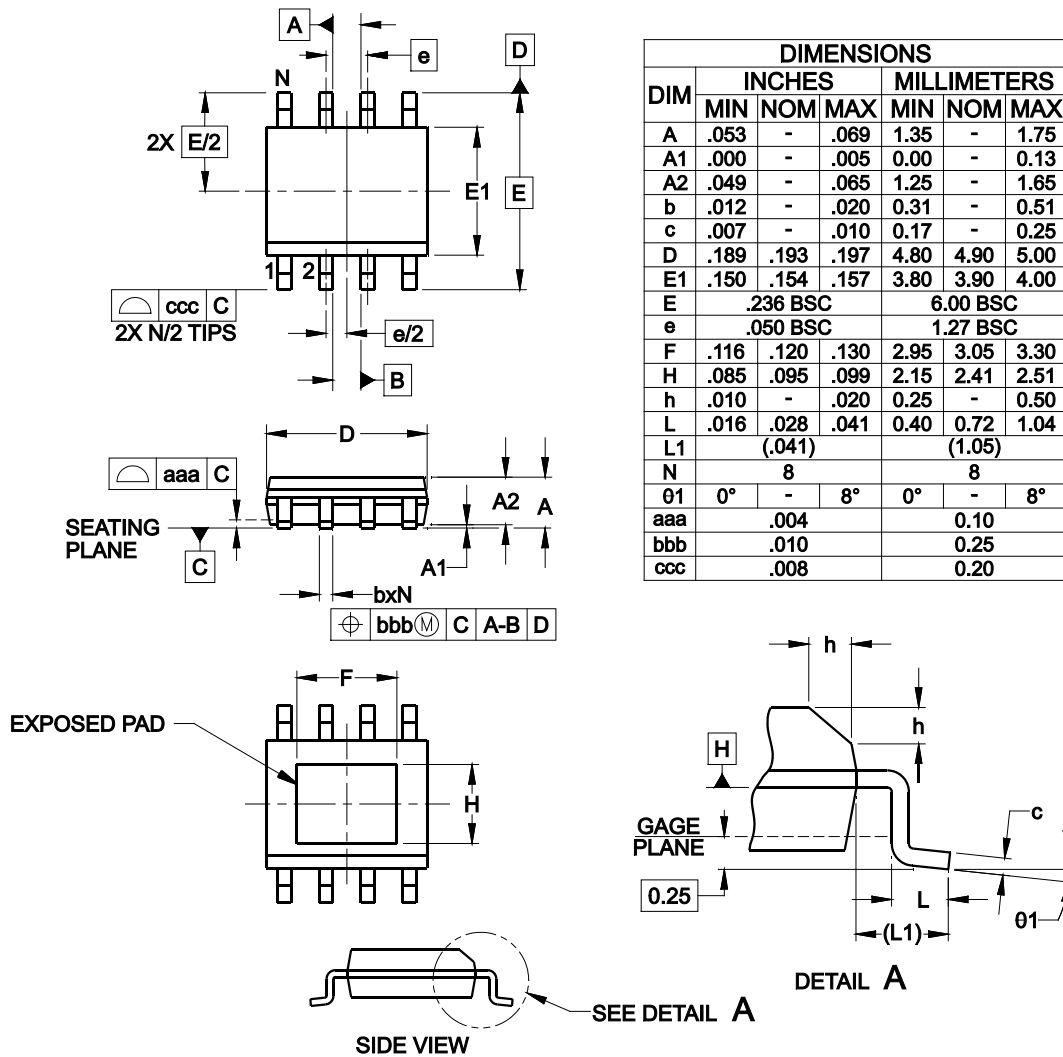

NOTES:

1. CONTROLLING DIMENSIONS ARE IN MILLIMETERS (ANGLES IN DEGREES).
2. DATUMS **-A-** AND **-B-** TO BE DETERMINED AT DATUM PLANE **-H-**
3. DIMENSIONS "E1" AND "D" DO NOT INCLUDE MOLD FLASH, PROTRUSIONS OR GATE BURRS.
4. REFERENCE JEDEC STD MS-012, VARIATION BA.

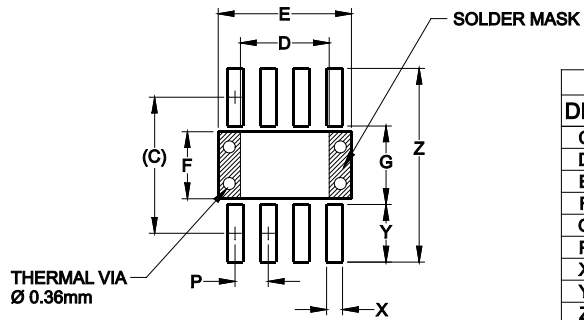
**Land Pattern — SOIC-8-EDP-2**

DIMENSIONS		
DIM	INCHES	MILLIMETERS
C	(.205)	(5.20)
D	.134	3.40
E	.201	5.10
F	.101	2.56
G	.118	3.00
P	.050	1.27
X	.024	0.60
Y	.087	2.20
Z	.291	7.40

**NOTES:**

1. THIS LAND PATTERN IS FOR REFERENCE PURPOSES ONLY. CONSULT YOUR MANUFACTURING GROUP TO ENSURE YOUR COMPANY'S MANUFACTURING GUIDELINES ARE MET.
2. REFERENCE IPC-SM-782A, RLP NO. 300A.
3. THERMAL VIAS IN THE LAND PATTERN OF THE EXPOSED PAD SHALL BE CONNECTED TO A SYSTEM GROUND PLANE. FAILURE TO DO SO MAY COMPROMISE THE THERMAL AND/OR FUNCTIONAL PERFORMANCE OF THE DEVICE.



© Semtech 2011

All rights reserved. Reproduction in whole or in part is prohibited without the prior written consent of the copyright owner. The information presented in this document does not form part of any quotation or contract, is believed to be accurate and reliable and may be changed without notice. No liability will be accepted by the publisher for any consequence of its use. Publication thereof does not convey nor imply any license under patent or other industrial or intellectual property rights. Semtech assumes no responsibility or liability whatsoever for any failure or unexpected operation resulting from misuse, neglect improper installation, repair or improper handling or unusual physical or electrical stress including, but not limited to, exposure to parameters beyond the specified maximum ratings or operation outside the specified range.

SEMTECH PRODUCTS ARE NOT DESIGNED, INTENDED, AUTHORIZED OR WARRANTED TO BE SUITABLE FOR USE IN LIFE-SUPPORT APPLICATIONS, DEVICES OR SYSTEMS OR OTHER CRITICAL APPLICATIONS. INCLUSION OF SEMTECH PRODUCTS IN SUCH APPLICATIONS IS UNDERSTOOD TO BE UNDERTAKEN SOLELY AT THE CUSTOMER'S OWN RISK. Should a customer purchase or use Semtech products for any such unauthorized application, the customer shall indemnify and hold Semtech and its officers, employees, subsidiaries, affiliates, and distributors harmless against all claims, costs damages and attorney fees which could arise.

Notice: All referenced brands, product names, service names and trademarks are the property of their respective owners.

## Contact Information

---

Semtech Corporation  
Power Management Products Division  
200 Flynn Road, Camarillo, CA 93012  
Phone: (805) 498-2111 Fax: (805) 498-3804

[www.semtech.com](http://www.semtech.com)