



Chipsmall Limited consists of a professional team with an average of over 10 year of expertise in the distribution of electronic components. Based in Hongkong, we have already established firm and mutual-benefit business relationships with customers from,Europe,America and south Asia,supplying obsolete and hard-to-find components to meet their specific needs.

With the principle of “Quality Parts,Customers Priority,Honest Operation,and Considerate Service”,our business mainly focus on the distribution of electronic components. Line cards we deal with include Microchip,ALPS,ROHM,Xilinx,Pulse,ON,Everlight and Freescale. Main products comprise IC,Modules,Potentiometer,IC Socket,Relay,Connector.Our parts cover such applications as commercial,industrial, and automotives areas.

We are looking forward to setting up business relationship with you and hope to provide you with the best service and solution. Let us make a better world for our industry!



Contact us

Tel: +86-755-8981 8866 Fax: +86-755-8427 6832

Email & Skype: info@chipsmall.com Web: www.chipsmall.com

Address: A1208, Overseas Decoration Building, #122 Zhenhua RD., Futian, Shenzhen, China



POWER MANAGEMENT

Description

The SC4431 is a four terminal device for regulating an isolated power supply with output voltages down to 1.5V.

It is intended to be used as a replacement for three terminal shunt regulators such as SC431L where the output voltage is too low for the device to function in conjunction with an opto-isolator. SC4431 achieves this by having separate supply and output pins, allowing the output to sink current at voltages as low as 0.1V, while the supply pin still has sufficient voltage for the device to function. In this way, allowing for a 1.4V drop through an opto-isolator diode, regulation down to 1.5V out can be achieved.

The SC4431 shunt regulator is available with three initial reference voltage accuracies (0.5%, 1.0% and 2.0%) in the space saving 5-lead SOT-23 package. The three voltage tolerances allow the designer the opportunity to select the proper cost/tolerance for their application.

Lead free, fully WEEE and ROHS compliant

Features

- ◆ Open Collector output drives Optoisolator with as little as 1.5V input voltage
- ◆ Trimmed bandgap design - initial accuracies to $\pm 0.5\%$
- ◆ 40mA drive capability
- ◆ Regulates output as low as 50mV
- ◆ Wide supply voltage range - 1.5V to 15V
- ◆ Low supply current - typically 110 μ A
- ◆ Full industrial temperature range
- ◆ SOT-23-5 package

Applications

- ◆ Telecom Power Supplies
- ◆ Opto driver for very low output voltage (1.5V) isolated power supplies
- ◆ Battery operated applications
- ◆ Point of use power supplies

Typical Application Circuit

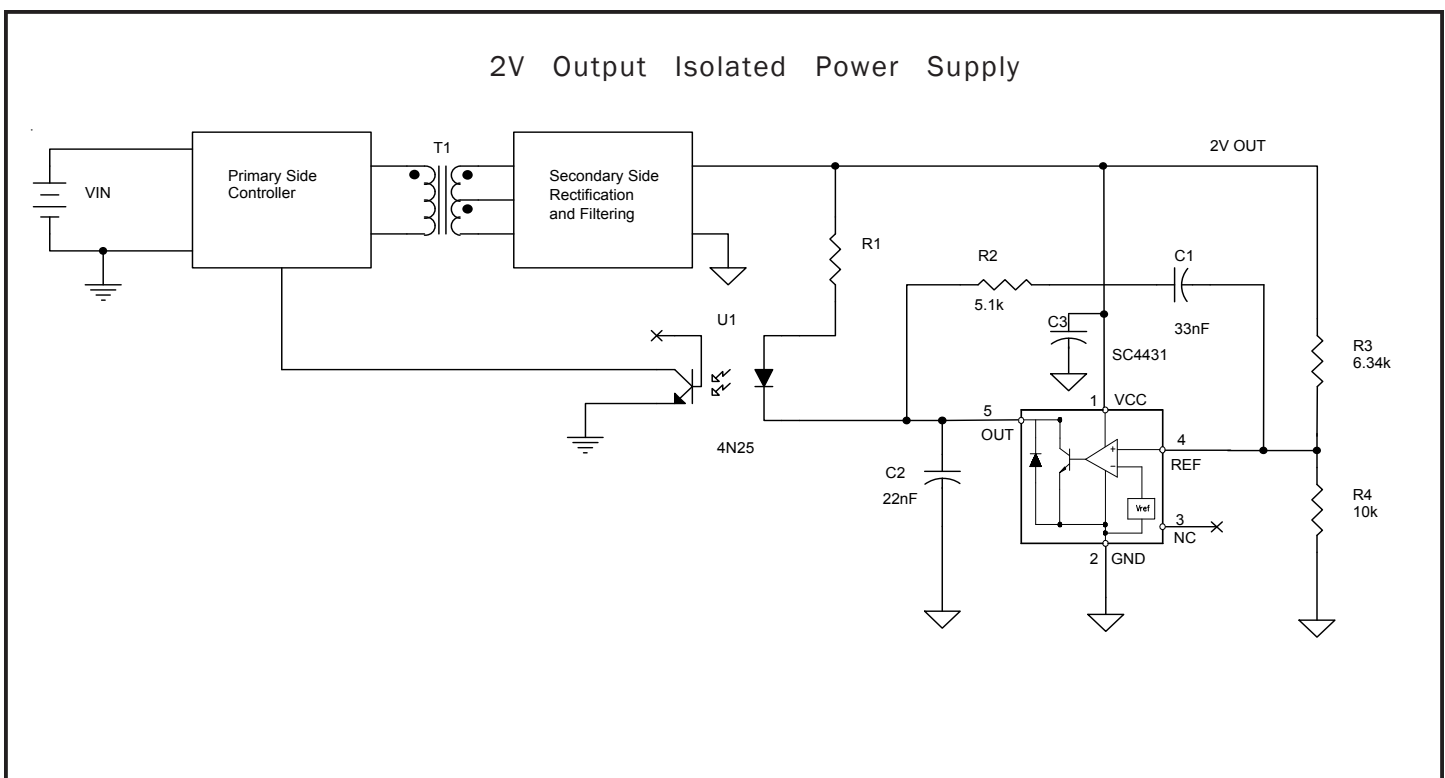

POWER MANAGEMENT

Absolute Maximum Rating

| Parameter | Symbol | Maximum | Units |
|---|---------------|-------------|-------|
| Input Supply Voltage | V_{CC} | -0.5 to +16 | V |
| Vcc pin current | I_{CC} | 8 | mA |
| Output Voltage | V_{OUT} | -0.5 to VCC | V |
| Reference Voltage ⁽¹⁾ | V_{REF} | -0.5 to +4 | V |
| Continuous Output Current | I_{OUT} | 40 | mA |
| Reference Input Current | I_{REF} | 5 | mA |
| Operating Ambient Temperature Range | T_A | -40 to +85 | °C |
| Operating Junction Temperature Range | T_J | -40 to +150 | °C |
| Storage Temperature Range | T_{STG} | -65 to +150 | °C |
| Thermal Impedance Junction to Ambient | θ_{JA} | 256 | °C/W |
| Thermal Impedance Junction to Case | θ_{JC} | 81 | °C/W |
| Power Dissipation at $T_A = 25^\circ\text{C}$ | P_D | 475 | mW |
| Lead Temperature (Soldering) 10 seconds | T_{LEAD} | 300 | °C |
| ESD Rating (Human Body Model) | ESD | 2 | kV |

(1) If Vref will be forced above 1.224V, a resistor must be placed in series with the Vcc to limit the Icc current below 5mA.

Electrical Characteristics

| Unless specified, $T_A = 25^\circ\text{C}$, $V_{CC} = 2\text{V}$, $I_{OUT} = 2\text{mA}$. Values in bold apply over full operating temperature range. | | | | | | |
|---|---------------------|---|--------------|-------|--------------|---------------|
| Parameter | Symbol | Test Conditions | MIN | TYP | MAX | Units |
| VCC | | | | | | |
| Input Supply Voltage | V_{CC} | | 1.5 | | 15 | V |
| Input Supply Current | I_{CC} | $V_{REF} = V_{OUT}$ | | 110 | 200 | μA |
| Off State Input Supply Current | $I_{CC(OFF)}$ | $V_{REF} = 1.187\text{V}$, $V_{OUT} = 2\text{V}$ | | 65 | 100 | μA |
| | | | | | 150 | |
| REF | | | | | | |
| Reference Voltage | V_{REF} | SC4431-.5, $V_{REF} = V_{OUT}$ | 1.219 | 1.224 | 1.231 | V |
| | | | 1.207 | | 1.243 | |
| | | SC4431-1, $V_{REF} = V_{OUT}$ | 1.212 | 1.224 | 1.236 | V |
| | | | 1.200 | | 1.250 | |
| | | SC4431-2, $V_{REF} = V_{OUT}$ | 1.200 | 1.224 | 1.250 | V |
| | | | 1.187 | | 1.261 | |
| Change in V_{REF} due to change in V_{CC} | dV_{REF}/dV_{CC} | $V_{CC} = 1.5\text{V to }15\text{V}$ | | 8 | 15 | mV |
| | | | | | 20 | |
| Change in V_{REF} due to change in I_{OUT} | dV_{REF}/dI_{OUT} | $I_{OUT} = 0.1\text{mA to }40\text{mA}$ | | 8 | 28 | mV |
| | | | | | 36 | |
| Reference Input Current | I_{REF} | $0.1\text{mA} \leq I_{OUT} \leq 10\text{mA}$ | | 0.3 | 0.5 | μA |
| | | | | | 1.0 | |
| OUT | | | | | | |
| Saturation Voltage | $V_{OUT(SAT)}$ | $I_{OUT} = 5\text{mA}$, $I_{CC} = 500\mu\text{A}$ | | 50 | 75 | mV |
| | | | | | 100 | |
| | | $V_{REF} = 1.261\text{V}$, $I_{OUT} = 32\text{mA}$ | | 275 | 300 | mV |
| | | | | | 400 | |
| Off State Output Current | $I_{OUT(OFF)}$ | $V_{REF} = 1.187\text{V}$, $V_{OUT} = 2\text{V}$ | | 0.50 | 1 | μA |
| | | | | | 10 | |

POWER MANAGEMENT

Pin Configurations

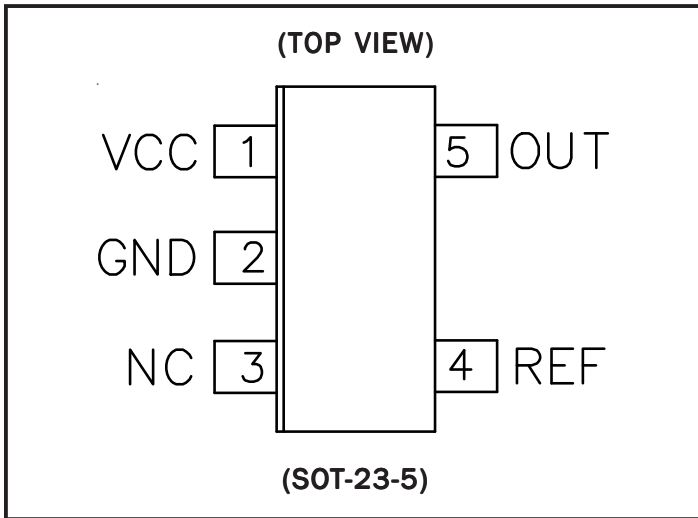

Ordering Information

| Part Number ⁽¹⁾⁽²⁾ | Package |
|-------------------------------|----------|
| SC4431CSK-X | SOT-23-5 |

Notes: (1) Only available in tape and reel packaging. (Suffix '.TRT' e.g. SC4431CSK-X.TRT).
 (2) Where "-X" denotes initial reference voltage tolerance. Available options are $\pm 0.5\%$ (-.5), $\pm 1\%$ (-1) and $\pm 2\%$ (-2).

Pin Descriptions

| Pin# | Pin Name | Pin Function |
|------|----------|---|
| 1 | VCC | This is the input supply pin for the SC4431. A low ESR capacitor should be used to bypass this pin to GND right at the IC. |
| 2 | GND | Logic and power ground. |
| 3 | NC | No connection. |
| 4 | REF | This is connected to the non-inverting input of the error amplifier. |
| 5 | OUT | This is the output pin of the device, essentially an open collector. Note: A 22nF low ESR (ceramic) capacitor is required from this pin to GND for stable operation. |

Block Diagram

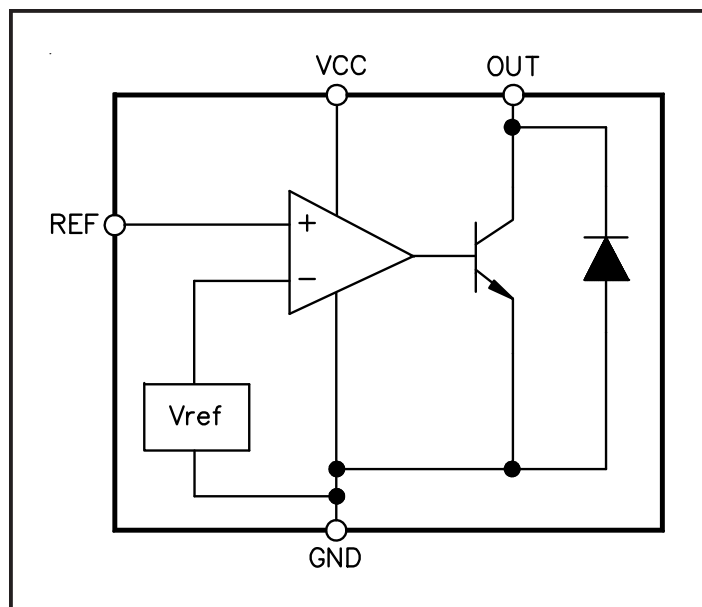

Marking Information

Top Mark

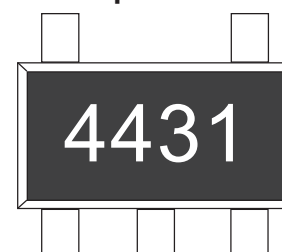

Bottom Mark

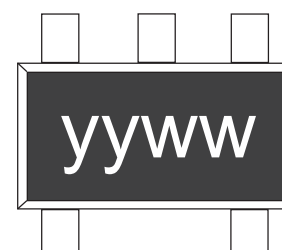

yyww = Datecode (Example: 9908)

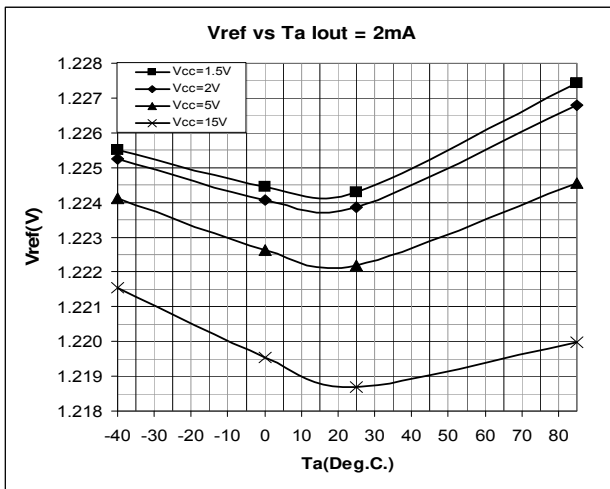

Typical Vref vs Ta I_o = 2mA

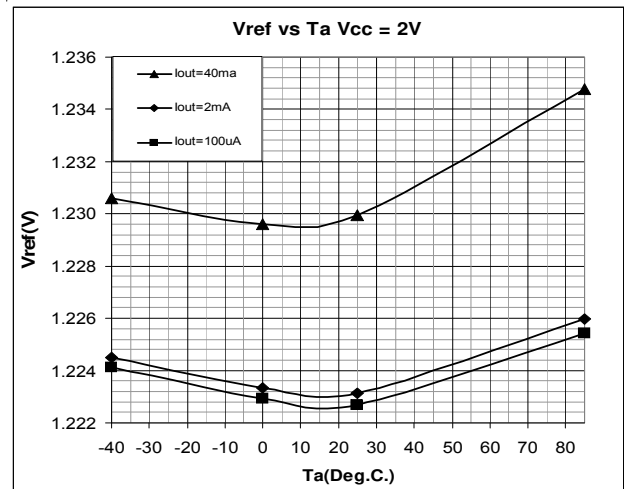

Typical Vref vs Ta V_{cc} = 2V

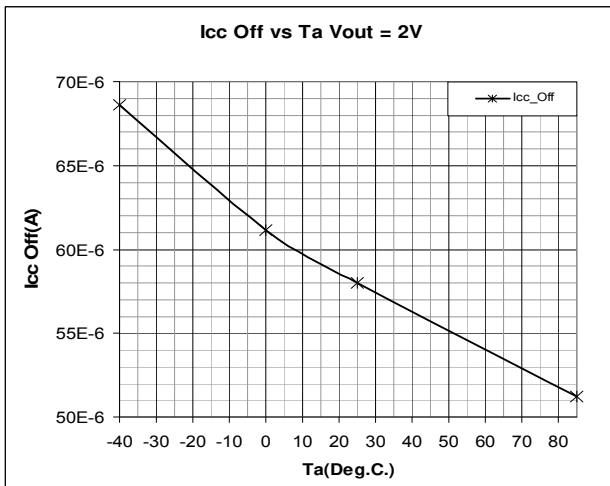

Typical I_{cc} Off vs Ta V_o = 2V

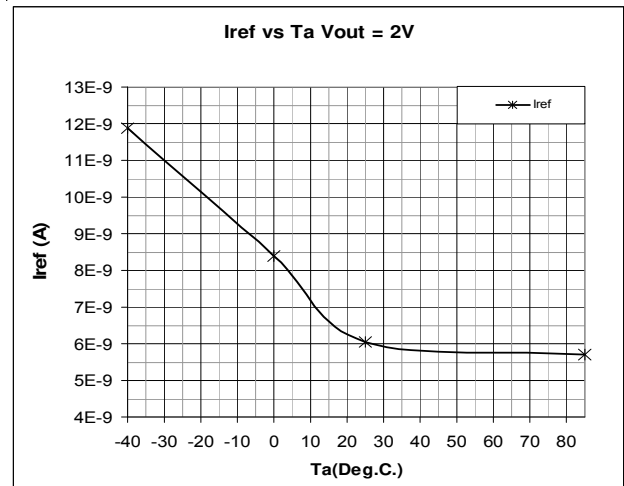

Typical I_{ref} vs Ta V_o = 2V

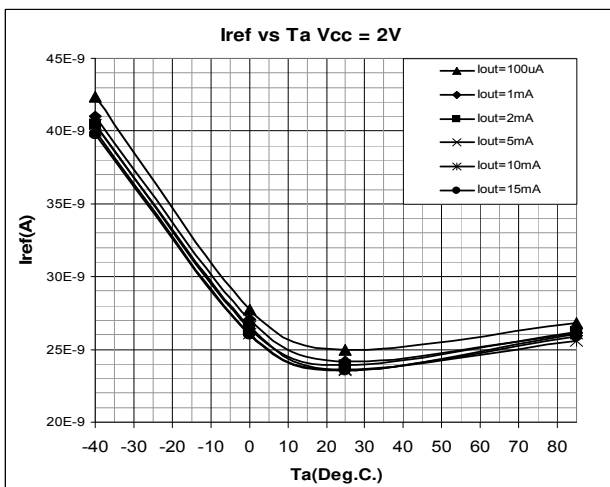

Typical I_{ref} vs Ta V_{cc} = 2V

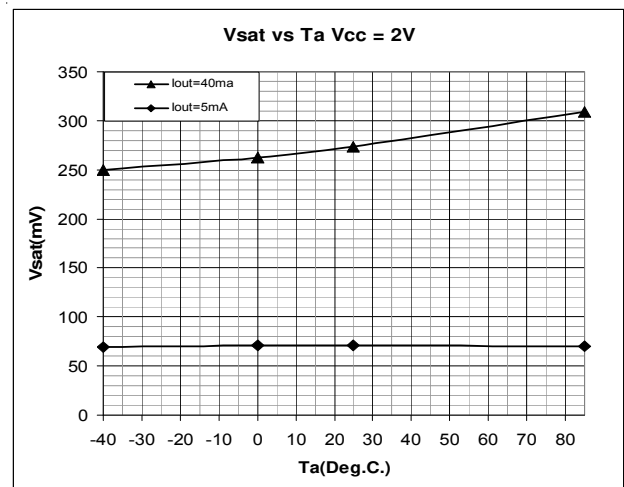

Typical V_{sat} vs Ta V_{cc} = 2V

POWER MANAGEMENT

Typical Characteristics

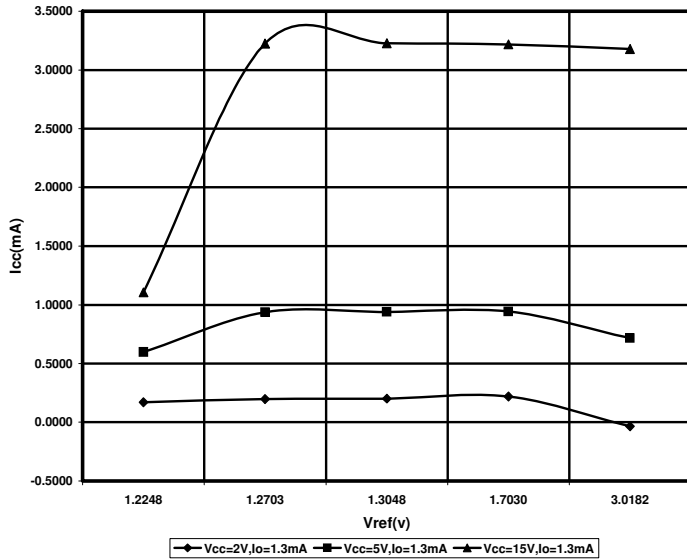

Typical Icc vs Vref, Io = 1.3mA, Ta = 25 Deg.C.

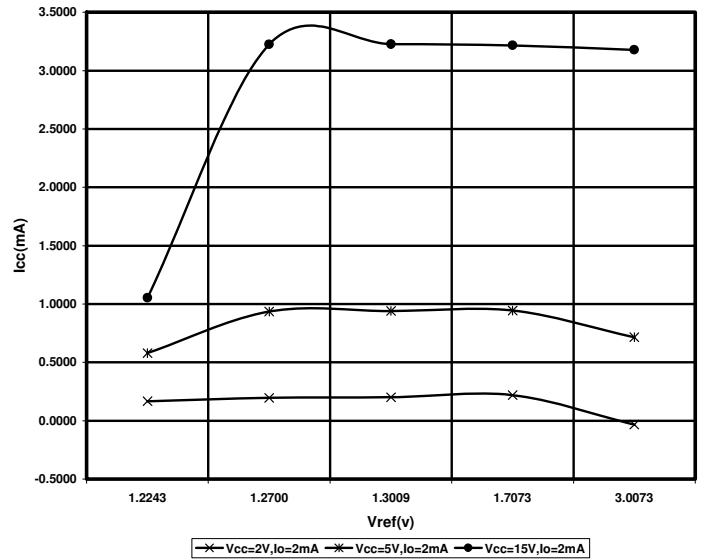

Typical Icc vs Vref, Io = 2mA, Ta = 25 Deg.C.

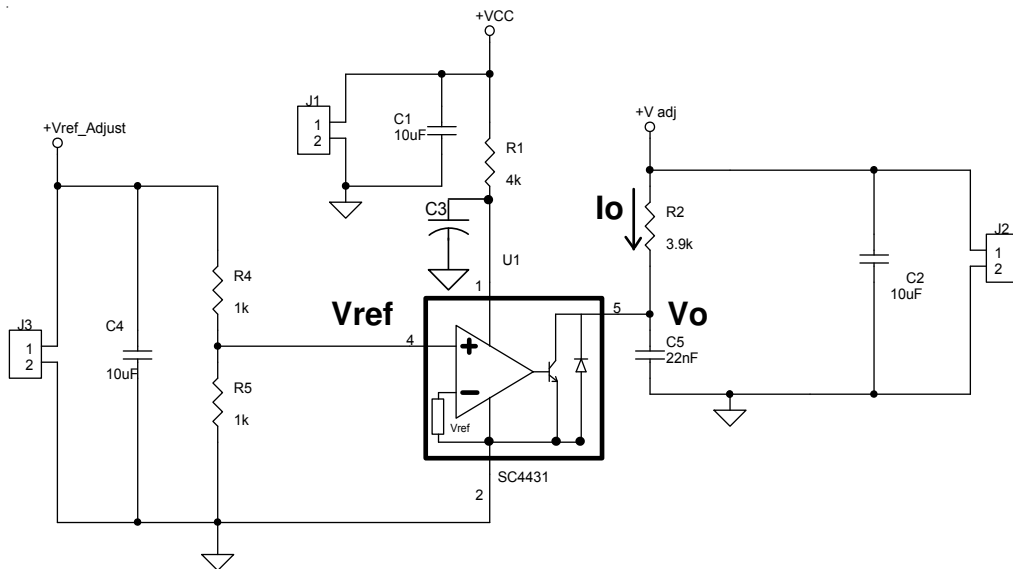

Icc vs Vref Test Circuit

Typical Gain Phase

SC4431 Gain / Phase Vin = 2V, Iout = 2mA, Vout = 1.6V

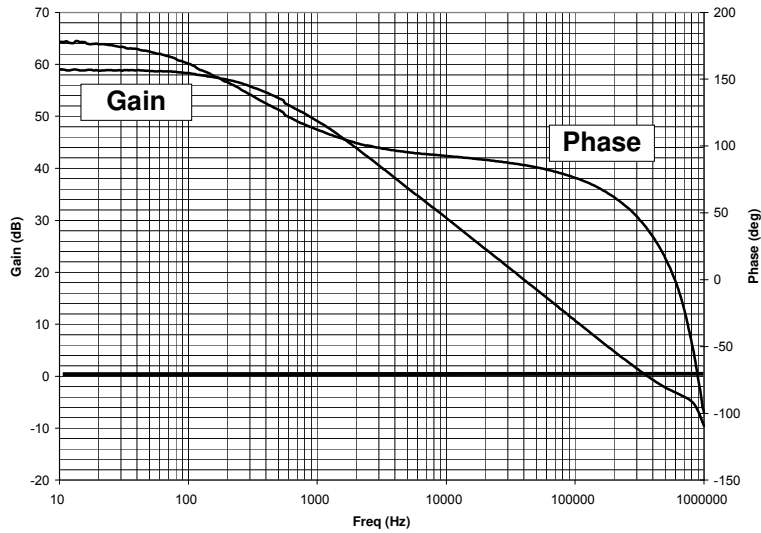

SC4431 Gain / Phase Vin = 4V, Iout = 2mA, Vout = 2V

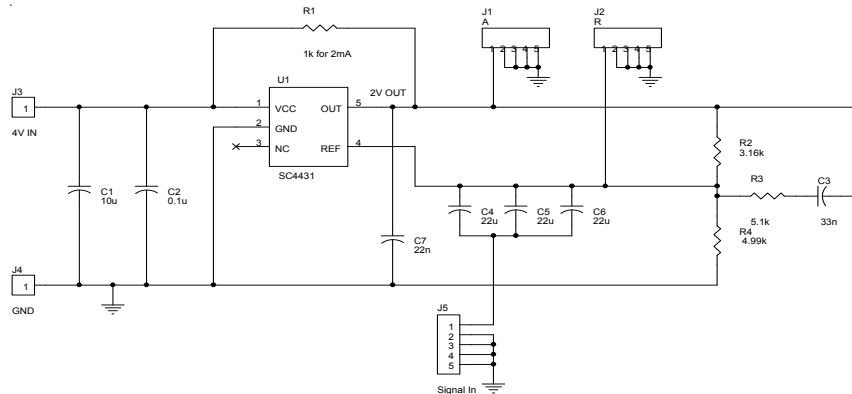
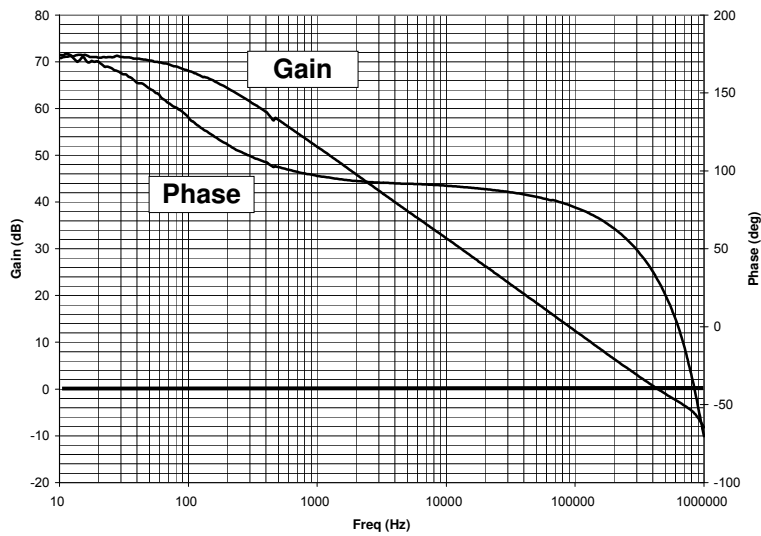

Gain Phase Test Circuit

POWER MANAGEMENT

Typical Applications

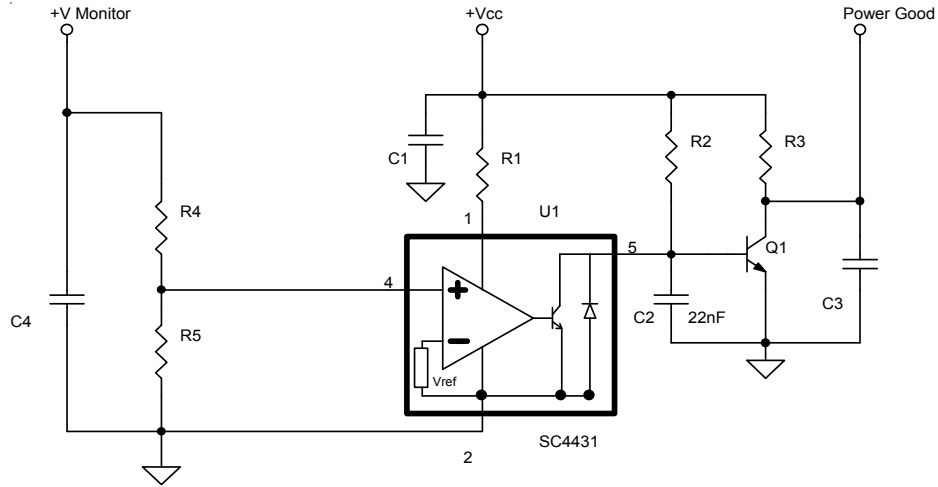

Power good Circuit

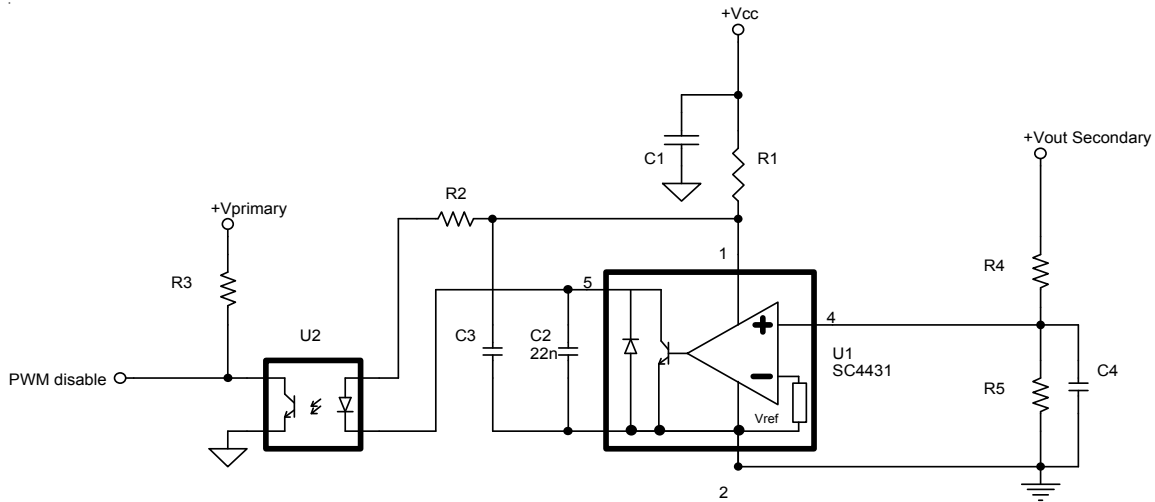

Isolated OVP Circuit

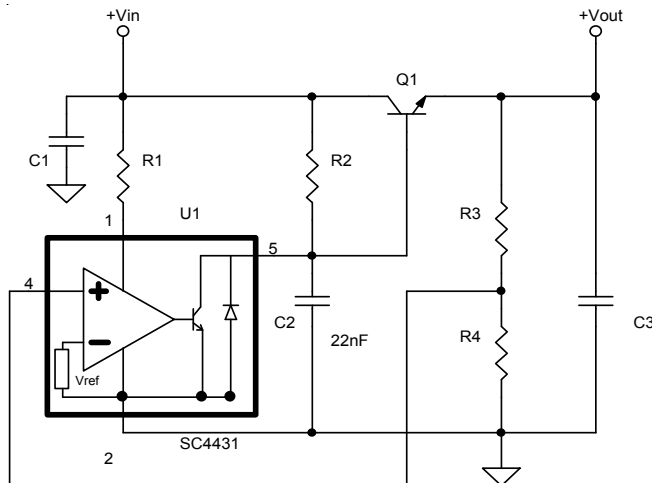

Linear Regulator Circuit

POWER MANAGEMENT

Outline Drawing

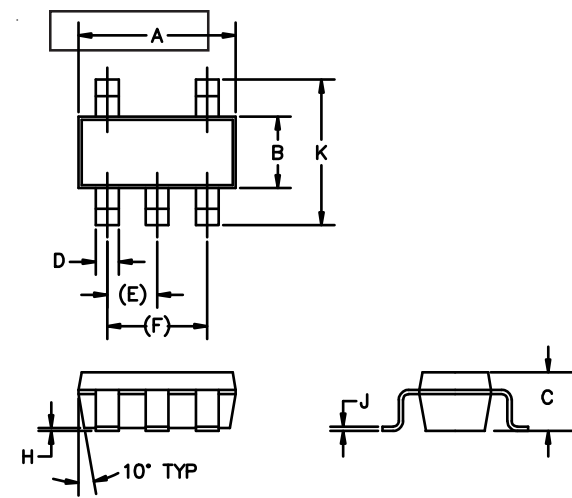

SOT-23- 5L ECN00 - 881

| DIM ^N | INCHES | | MM | | NOTE |
|------------------|--------|------|------|------|------|
| | MIN | MAX | MIN | MAX | |
| A | .110 | .120 | 2.80 | 3.05 | — |
| B | .059 | .070 | 1.50 | 1.75 | — |
| C | .036 | .051 | .90 | 1.30 | — |
| D | .014 | .020 | .35 | .50 | — |
| E | — | .037 | — | 0.95 | REF |
| F | — | .075 | — | 1.90 | REF |
| H | — | .006 | — | .150 | — |
| J | .0035 | .008 | .090 | .20 | — |
| K | .102 | .118 | 2.6 | 3.00 | — |

CONTROLLING DIMENSIONS: MILLIMETERS.

Land Pattern

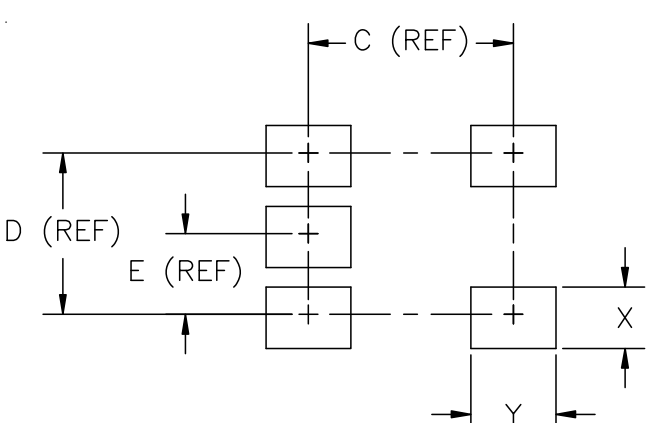

SOT- 23- 5L ECN00 - 881

| DIM ^N | INCHES | | MM | | NOTE |
|------------------|--------|-----|----|------|------|
| | INCHES | MM | MM | NOTE | |
| C | .094 | 2.4 | — | — | |
| D | .074 | 1.9 | — | — | |
| E | .037 | .95 | — | — | |
| X | .028 | .7 | — | — | |
| Y | .039 | 1.0 | — | — | |

Contact Information

Semtech Corporation
 Power Management Products Division
 200 Flynn Road, Camarillo, CA 93012
 Phone: (805)498-2111 FAX (805)498-3804