



Chipsmall Limited consists of a professional team with an average of over 10 year of expertise in the distribution of electronic components. Based in Hongkong, we have already established firm and mutual-benefit business relationships with customers from,Europe,America and south Asia,supplying obsolete and hard-to-find components to meet their specific needs.

With the principle of "Quality Parts,Customers Priority,Honest Operation,and Considerate Service",our business mainly focus on the distribution of electronic components. Line cards we deal with include Microchip,ALPS,ROHM,Xilinx,Pulse,ON,Everlight and Freescale. Main products comprise IC,Modules,Potentiometer,IC Socket,Relay,Connector.Our parts cover such applications as commercial,industrial, and automotives areas.

We are looking forward to setting up business relationship with you and hope to provide you with the best service and solution. Let us make a better world for our industry!



Contact us

Tel: +86-755-8981 8866 Fax: +86-755-8427 6832

Email & Skype: info@chipsmall.com Web: www.chipsmall.com

Address: A1208, Overseas Decoration Building, #122 Zhenhua RD., Futian, Shenzhen, China



POWER MANAGEMENT

Description

The SC4505 is a high-frequency PWM current-mode step-up switching regulator with an integrated 2A power transistor. Its high switching frequency (1MHz) allows the use of tiny surface-mount external passive components. The internal switch is rated at 36V which makes the converter ideal for multiple LED series operation with optimal current matching. Two programmable independent current source structure allows dual panel LED backlight and flash operation.

The operating frequency of the SC4505 is set at 1MHz. The selected operating frequency gives the SC4505 design flexibility for size, cost and efficiency optimization. The SC4505 is available in thermally enhanced 16-pin MLPQ package (3x3x0.9mm) with embedded over temperature protection.

Features

- ◆ Two independent current sources for dual LED strands with optimal current/light matching. Backlight up to 75mA, Flash up to 125mA
- ◆ Wide input range from 2.6V to 12V
- ◆ Adaptive output voltage up to 28V with OVP protection against open circuit conditions
- ◆ Low shutdown current (<1 μ A)
- ◆ Internal Flash/Torch mode with flash timeout to protect LEDs
- ◆ 1MHz Fixed Frequency Current-Mode Control
- ◆ Internal 2A current limit for driving large numbers of LEDs
- ◆ Supports PWM Dimming from 50Hz to 50kHz
- ◆ Internal undervoltage lockout
- ◆ Small, low profile, thermally enhanced 16-MLPQ package is fully WEEE and RoHS compliant

Applications

- ◆ White LED power supplies
- ◆ Flat screen LCD bias supplies
- ◆ TFT bias supplies
- ◆ Dual panel Handset/Liquid Crystal Display Monitor
- ◆ Portable media players
- ◆ Digital video cameras
- ◆ Digital still cameras

Typical Application Circuit

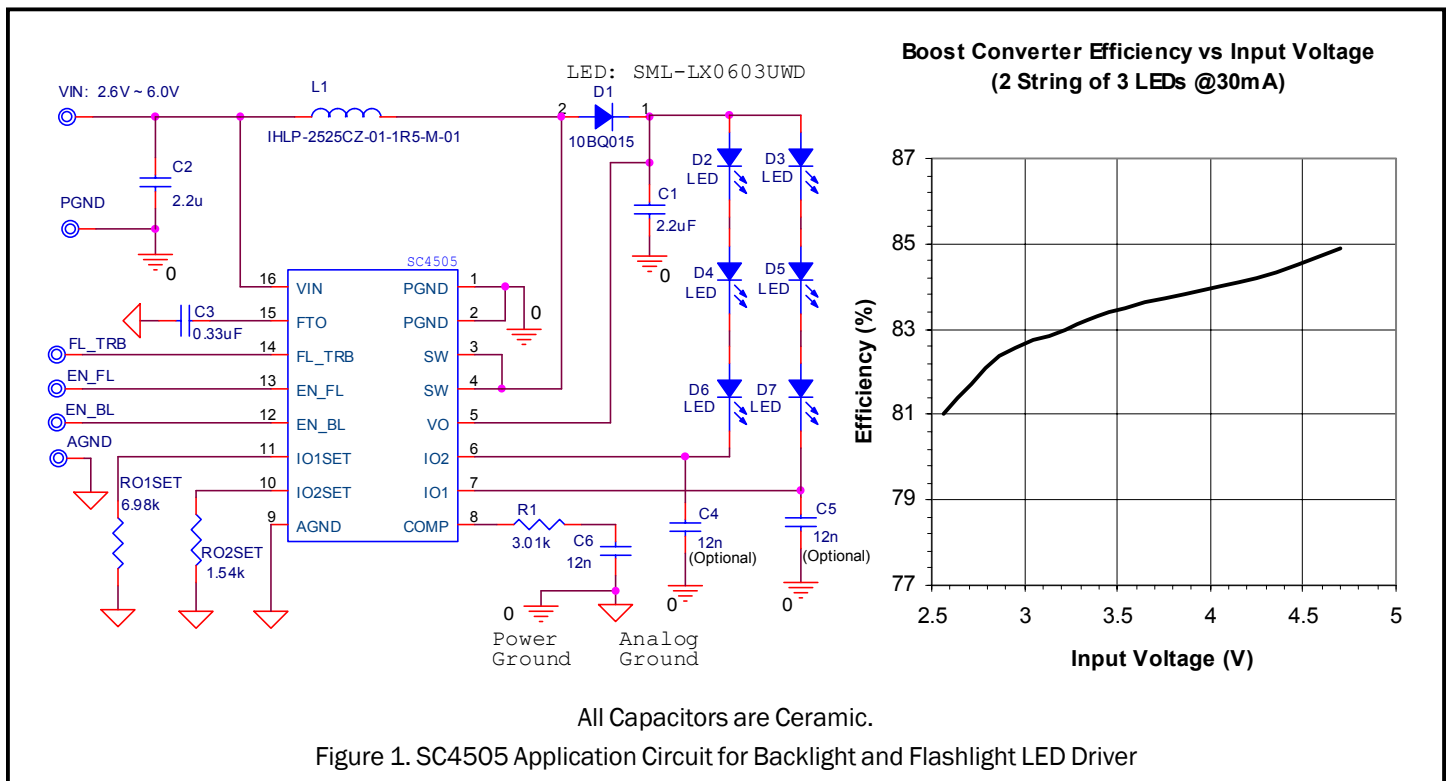

POWER MANAGEMENT
Absolute Maximum Rating

Exceeding the specifications below may result in permanent damage to the device, or device malfunction. Operation outside of the parameters specified in the Electrical Characteristics section is not implied. Exposure to Absolute Maximum rated conditions for extended periods of time may affect device reliability.

Parameter	Symbol	Typ	Units
Supply Voltage	V_{IN}	-0.3 to 20	V
SW Voltage, Output Voltage, Current Source Voltage	$V_{SW}, V_O, V_{IO1}, V_{IO2}$	-0.3 to 36	V
I_{OSET} Voltage	V_{IO1SET}, V_{IO2SET}	-0.3 to 2	V
FTO Voltage	V_{FTO}	-0.3 to $V_{IN} + 0.3$	V
EN_BL, EN_FL, FL_TRB Voltage	$V_{EN_BL}, V_{EN_FL}, V_{FL_TRB}$	-0.3 to $V_{IN} + 0.3$	V
Thermal Resistance Junction to Ambient	θ_{JA}	37	°C/W
Maximum Junction Temperature	T_J	150	°C
Storage Temperature Range	T_{STG}	-65 to +150	°C
IR Reflow (Soldering) 10s to 30s	T_{PKG}	260	°C
ESD Rating (Human Body Model)	ESD	1	kV

Electrical Characteristics

Unless specified: $V_{IN} = 3.6V$, $-40^{\circ}C < T_A = T_J < 85^{\circ}C$, $R_{O1SET} = 6.98K\Omega$, $R_{O2SET} = 1.54K\Omega$

Parameter	Test Conditions	Min	Typ	Max	Unit
Supply Input Voltage V_{IN}		2.6		12	V
UVLO Threshold	V_{IN} rising		2.45	2.59	V
UVLO Hysteresis			50		mV
V_{IN} Supply Current	Not switching		1.7		mA
V_{IN} Supply Current in Shutdown	EN_FL = FL_TRB = EN_BL = 0			1.0	μA
Switching Frequency	$T_J = 25^{\circ}C$	0.8	1	1.2	MHz
Maximum Duty Cycle		85	90		%
Minimum Duty Cycle				0	%
Switch Current Limit		1.75	2.25		A
Switch Leakage Current	$V_{SW} = 28V$		0.01	1	μA
Switch Saturation Voltage	$I_{SW} = 1A$		300		mV
EN_FL, FL_TRB, EN_BL High Voltage	$V_{IN} = 2.6V$ to 4.7V	2			V
EN_FL, FL_TRB, EN_BL Low Voltage	$V_{IN} = 2.6V$ to 4.7V			0.4	V

POWER MANAGEMENT
Electrical Characteristics (Cont.)

 Unless specified: $V_{IN} = 3.6V$, $-40^{\circ}C < T_A = T_J < 85^{\circ}C$, $R_{O1SET} = 6.98K\Omega$, $R_{O2SET} = 1.54K\Omega$

Parameter	Test Conditions	Min	Typ	Max	Unit
EN_FL, FL_TRB, EN_BL Input Current	$V_{EN_FL} = 0V \text{ to } 4.7V$		0.01	1	μA
EN_BL PWM Dimming Control Frequency	Note 1	50		50K	Hz
EN_BL PWM Dimming Control Duty Cycle	$F_{PWM} = 32kHz$, Note 1	12		100	%
FTO Sourcing Current	$EN_FL = FL_TRB = 1$		1.2		μA
FTO Trip Threshold Voltage			1.25		V
FTO Pull Down Current	$EN_FL = 1, FL_TRB = 0$		2.6		mA
Overvoltage Protection			28		V
Thermal Shutdown Temperature			155		$^{\circ}C$
Thermal Shutdown Hysteresis			10		$^{\circ}C$
Backlight Current Accuracy (I_{O1})	$EN_BL = 1$ $T_J = 25^{\circ}C, R_{O1SET} = 6.98K\Omega$	19	20	21	mA
Max Backlight Current (I_{O1})			75		mA
Flash Current Accuracy (I_{O2})	$EN_FL = FL_TRB = 1$ $T_J = 25^{\circ}C, R_{O2SET} = 1.54K\Omega$	92	100	108	mA
Max Flash Current (I_{O2})			125		mA
Torch Output Current (I_{O2})	$EN_FL = 1, FL_TRB = 0$ $T_J = 25^{\circ}C, R_{O2SET} = 1.54K\Omega$		18		mA
I_{O1} Off Leakage Current	$V_{IO1} = 28V$		0.1	1	μA
I_{O2} Off Leakage Current	$V_{IO2} = 28V$		0.1	1	μA
V_O Pulldown in Overvoltage Fault			7		$K\Omega$

Note 1: Guaranteed by Design

POWER MANAGEMENT

Pin Configurations

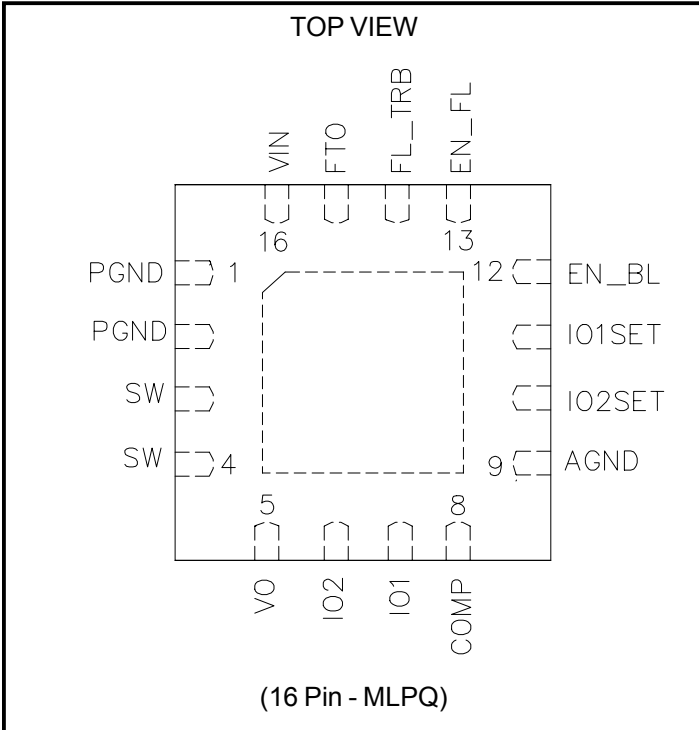

Ordering Information

Device ⁽¹⁾⁽²⁾	Package	Temp. Range(T _A)
SC4505MLTRT	MLPQ-16	-40 to 85°C
SC4505EVB ⁽³⁾	EVALUATION BOARD	

Notes:

- (1) Only available in tape and reel packaging. A reel contains 3000 devices.
- (2) Lead free product. This product is fully WEEE and RoHS compliant.
- (3) Consult factory for all other available options.

Block Diagram

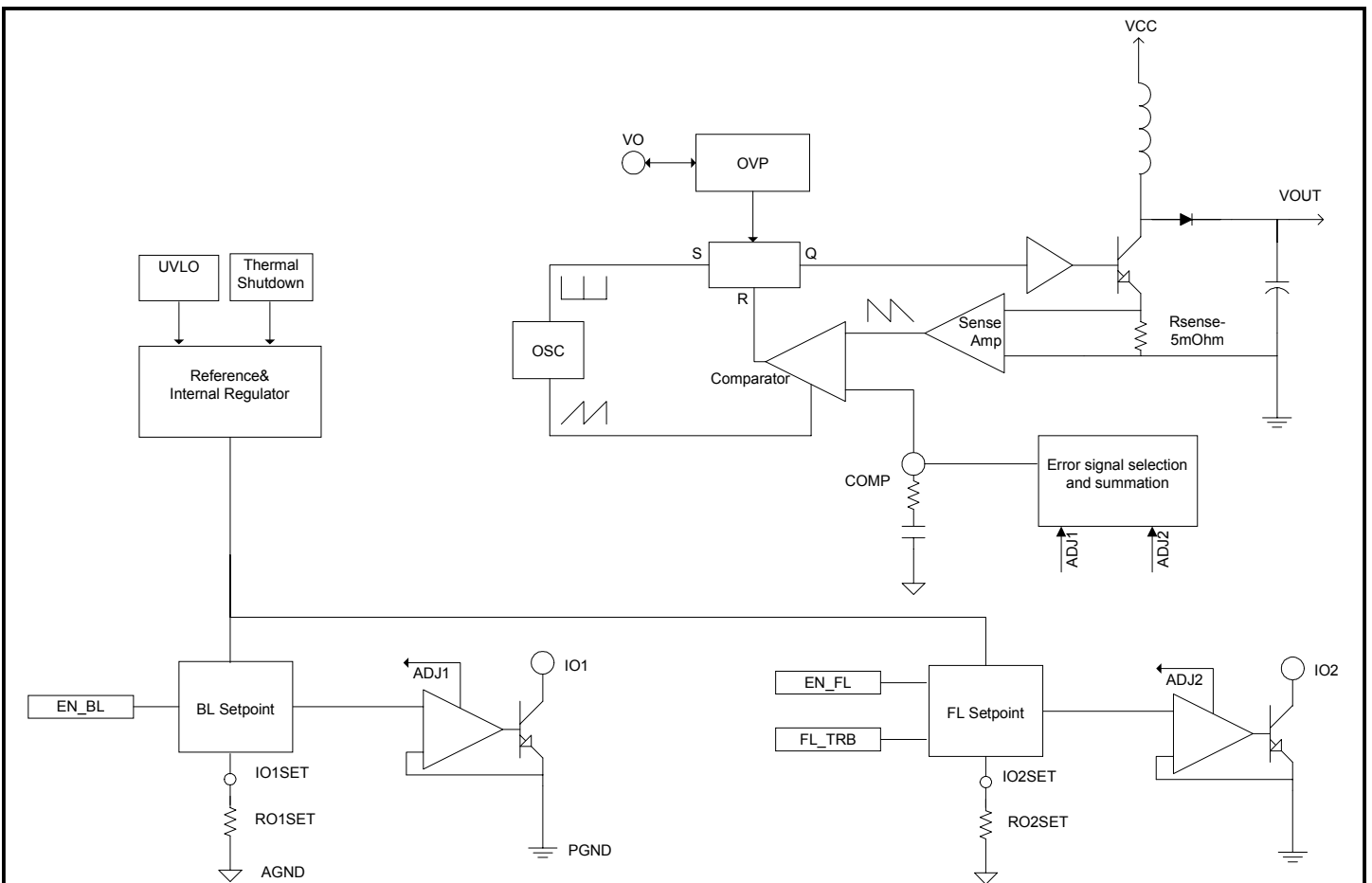

POWER MANAGEMENT

Pin Descriptions

Pin	Pin Name	Pin Function
1,2	PGND	Power ground.
3,4	SW	Collector of the internal power transistor. Connect to the boost inductor and the rectifying diode.
5	VO	Boost output voltage pin. Internal overvoltage protection also monitors the voltage at this pin. Connect the output capacitor and the anode of the LED strings to this pin.
6	IO2	Provides constant source current to LED string 2.
7	IO1	Provides constant source current to LED string 1.
8	COMP	The output of the internal transconductance error amplifier. This pin is used for loop compensation.
9	AGND	Analog ground.
10	IO2SET	Current source IO2 value set pin. By selecting the resistor connected from this pin to GND, the corresponding maximum current on string 2 is set.
11	IO1SET	Current source IO1 value set pin. By selecting the resistor connected from this pin to GND, the corresponding maximum current on string 1 is set.
12	EN_BL	Enable and Brightness control pin for LED backlight string 1. (See Table 2 for logic).
13	EN_FL	
14	FL_TRB	Enable and Brightness control pin for LED flash light string 2. (See Table 1 for logic).
15	FTO	Flash time out pin. By selecting the capacitor connected to this pin, the time out duration is determined. By pulling this pin to AGND, the FTO function is disabled.
16	VIN	Power Supply Pin. Bypassed with capacitors close to the pin.
	Exposed Pad	The exposed pad must be soldered to the analog ground plane on the PCB for good thermal conduction.

EN_FL	FL_TRB	Status
0	0	Flash disable
0	1	Flash disable
1	0	20% max. output current set by external resistor, RO2SET
1	1	100% max. output current set by external resistor, RO2SET

Table 1

Note: When EN_FL = 0
 FL_TRB = 0
 EN_BL = 0

The boost is turned OFF and disabled.

EN_BL	Status
0	Backlight disable
1	Backlight enable

Table 2

POWER MANAGEMENT

Overview

The SC4505 contains a 1MHz fixed-frequency, current-mode boost converter, and two independent LED current regulators. The LED current setpoints are chosen using external resistors, and the PWM controller operates independently to keep the two currents in regulation. Since the SC4505 receives feedback from both of the LED current regulators, either or both LED strands can be on at any given time. Additionally, different numbers of LED can be used in the two strands with no resistor ballasting, or preset output voltage setpoint.

A typical application would use 3-6 backlight LED, driven with 20mA, and 2-6 flash LED, driven with 20mA during torch mode (video recording), and driven with 100mA during flash mode (for photographs). Usually only the backlight LED are used, but during some cases both strands must be on at the same time. As the output voltage is different for each case, a designer is often forced to use lossy ballast resistors to balance the LED currents, or to use two separate converter ICs, greatly increasing component count and BOM cost.

The SC4505 solves these issues by controlling the boost converter set point based on instantaneous requirements of the two current regulators. Therefore, only a single inductor and power switch is needed to provide power to the entire lighting subsystem, increasing efficiency and reducing part count. A digital interface allows independent control of all LED currents with no converter “babysitting”. Interface to output control is high-bandwidth, supporting digital PWM dimming on any channel at 50Hz to 50kHz dimming frequency, while aggressively shutting the entire IC down to less than 1 μ A shutdown mode when all LED strands are turned off. In shutdown mode, leakage through the current regulator outputs is also < 1 μ A, keeping the output capacitor charged and ready for instant activation of the LED strands.

1 MHz switching speed provides high output power using a tiny 1.0mm high inductor, maximizing efficiency for space-constrained and cost-sensitive applications. In addition, converter and output capacitor are protected from open-LED conditions by overvoltage protection, and flash LED are protected from burnout by a user-settable time-out feature.

The states of the two LED current regulators are chosen by a three-bit digital input. Either or both of the current regulators can be on at any given time. The converter automatically shuts down to zero-current shutdown mode if all pins are low.

EN_BL – Enable Backlight regulator (I_{01}).

EN_FL – Enable Flash/Torch regulator (I_{02})

FL_TRB – Select flash or torch mode for I_{02} . The current in torch mode is approximately 1/5 of the current in flash mode. Flash mode when FL_TRB = 1.

POWER MANAGEMENT

Applications Information

Boost Converter Setup

The SC4505 is a fixed-frequency, current mode step-up DC-DC converter that is ideal for driving LEDs in the applications in which both backlighting and flashighting are needed.

Unlike the ballasting resistor scheme, multiple strands can be independently controlled, or shut off entirely without leaking current from a charged output capacitor or causing false-lighting with low LED count and high VIN. It also enables regulation of several output setpoints using a single inductor. For example, if a user has three Backlight LEDs and four Flash LEDs, output may need to be as high as 16V during flash mode, or as low as 10V during backlight mode. If both of the strands can be “on” at the same time, it is impossible to regulate using the FB ballast method unless an additional resistor is used to take up the 6V mismatch. This forces the output voltage to the full 16V which is not needed in the nominal case. Typically, two separate converters are used in this case. Neither of these cases is suitable in cost or efficiency-conscious applications.

The SC4505 boost converter receives information from both of the LED current regulators, and drives the output to the proper setpoint with no user intervention. The controller quickly drives to one of three separate limit cases, based on voltage requirement of the strands (number of LED, and LED current), which is shown in Table 3. In the table, it is assumed that the forward voltage drops of all the LEDs are the same. And the assumption applies to the the rest of analysis in the data sheet.

Case	Condition	Operation
Single Strand	One Strand Only	Regulate to Current Strand
Backlight Limited	Number of Backlight LEDs > Number of Flashlight LEDs	Servos to the Number of Backlight LEDs. Flashlight is still Regulated to I _{o2} Set Value
Flashlight Limited	Number of Backlight LEDs < Number of Flashlight LEDs	Servos to the Number of Flashlight LEDs. Backlight is still Regulated to I _{o1} Set Value

Table 3. SC4505 Operation States

An important note is that continuous operation of mismatched LED strands deteriorates the efficiency of the overall lighting subsystem because the extra voltage must be dropped across that output of the current regulator. Fortunately, for the cases of high mismatch such as the backlight/flashlight example previously mentioned, the time duration in which both heavily mismatched LEDs strands are “on” is very short. Furthermore, the sacrifice of 5-10% efficiency loss is negligible when compared to the overall cost reduction of the single-IC and single-inductor solution.

Inductor Selection

Selection of power-stage components for system optimal performance is often a lengthy and tedious process. Much effort has been put into the straightforward implementation of the SC4505. The converter operates preferably in DCM, to reap the advantages of small inductance and quick transient response while avoiding the bandwidth-limiting instability of the RHP zero found in CCM boost converters. Using this strategy, the loop bandwidth is extended to over 100 kHz, allowing the converter to lock into regulation even when dimming with PWM frequencies as high as 50 kHz.

In many cases, the required output currents from a tiny inductor footprint limit the designer to very small values of inductance (0.8 - 2.2μH). Inductor selection, for SC4505 based applications, begins with estimation of output current and step-up ratios.

Design example of four backlight LEDs with three flash LEDs.

Backlight only:
Largest step up: 2.7V to 14.4V @20mA (81% Duty)

Flashlight only:
Largest step up: 2.7V to 12V @ 100mA (78% Duty)

Both Strands: It requires: 14.4V @120mA

Suppose the efficiency of the boost converter is about 80%, the Maximum average input current is:

$$14.4V \times 120mA / (2.7V \times 80\%) = 0.8A.$$

Suppose a 1.5μH inductor is used, the peak inductor current would be:

POWER MANAGEMENT
Applications Information

$$I_{PK} = 0.8A + \left(\frac{2.7V}{1.5\mu H} \right) \times 1\mu S \times 81\% \times \frac{1}{2} = 1.5A$$

When using tiny inductors for size-sensitive applications, only a few limited selections are available that fulfill this need, and all are within the low μH range of inductance. We select a Coiltronics 1.5 μH SD3114 series, presently the only 3mmx3mmx1.5mm inductor that can provide the required current in the microminiature size required in space-constrained applications.

Table 4 shows a list of several low profile inductor manufacturers. Please consult the manufacturers for detailed information on their entire selection of power inductors.

PART	L (μH)	MAX DCR (Ω)	MAX HEIGHT (mm)	VENDOR
SD3112-1R0 SD3114-1R5 SD3114-4R7	1.0 1.5 4.7	0.069 0.057 0.147	1.2 1.45 1.45	Coiltronics www.cooperet.com
LQH3C4R7M24 LQH3C100M24	4.7 10	0.260 0.300	2.2 2.2	Murata www.murada.com
LB2016B4R7 LB2016B100	4.7 6.8	0.250 0.350	1.6 1.6	Taiyo Yuden www.t-yuden.com
CMD4D06-4R7 CLQ4D10-4R7 CLQ4D10-6R8	4.7 4.7 6.8	0.216 0.162 0.195	0.8 1.2 1.2	Sumida www.sumida.com
IHLP2525CZ1R5 IHLP2525CZ3R3 IHLP2525CZ4R7	1.5 3.3 4.7	0.014 0.028 0.037	3.0 3.0 3.0	Vishay www.vishay.com

Table 4. Recommended Inductors

Output Capacitor Selection

The next task in SC4505 design is targeting the proper amount of ripple voltage due to the constant-current LED loads. The two error amplifiers that control the PWM converter sense the delta between requested current and actual current in each output current regulator. On a cycle-by-cycle basis, a small amount of output ripple ensures good sensing and tight regulation, while the output current regulators keep each LED current at a fixed value. Overall, this allows usage of small output caps while ensuring precision LED current regulation.

Although the mechanics of regulation and frequency dependence may be complex, actual selection of output capacitor can be simplified to two boundary conditions, minimum output current and maximum output current. Output capacitor is chosen to keep ripple voltage between 10mV & 200mV under all loads.

Design example for Backlight=20mA, Flashlight=100mA:

Minimum Load Current: 20mA (Backlight Only)

Maximum Load Current: 120mA (Backlight and Flash)

All other cases (Torch mode only, Flash mode only, Backlight and Torch) fall within these two boundary conditions, so they are automatically satisfied by the selected output capacitor.

Since the load is a constant current, the capacitor

equation $\Delta I = C \cdot \left(\frac{\Delta V}{\Delta T} \right)$ can be solved for the output ripple.

$$\Delta V_{OUT} = \frac{I_{OUT}}{C_{OUT}} \times 1\mu S \times (1-D)$$

At 1MHz switching frequency and with the assumption of the worse case analysis ($D=0$), an even simpler relationship can be applied:

$$\Delta V_{OUT} = \frac{I_{OUT}}{C_{OUT}} \times 1\mu S$$

where C_{OUT} is in μF .

For worse case analysis, We see that our typical case of 20mA, 120mA can be immediately converted into its corresponding ripple relationships of:

$$\Delta V_{OUTMIN} = 20mV / C_{OUT}$$

where C_{OUT} is in μF .

$$\Delta V_{OUTMAX} = 120mV / C_{OUT}$$

where C_{OUT} is in μF .

For the example, if 1 μF output capacitor were used, the 20mV/120mV boundary conditions are well within the suggested guidelines.

Recommended ceramic capacitor manufacturers are listed in Table 5.

POWER MANAGEMENT

Applications Information

VENDOR	PHONE	WEBSITE
KEMET	408-986-0424	www.kemet.com
Murata	814-237-1431	www.murada.com
Taiyo Yuden	408-573-4150	www.t-yuden.com

Table 5. Recommended Ceramic Capacitor Manufacturers

Output Rectifying Diode Selection

Schottky diodes are the ideal choice for SC4505 due to their low forward voltage drop and fast switching speed. Table 6 shows several different Schottky diodes that work well with the SC4505. Make sure that the diode has a voltage rating greater than the possible maximum output voltage. The diode conducts current only when the power switch is turned off. So a 1A diode will be sufficient for most designs.

PART	VENDOR
SS13 SS14	Vishay www.vishay.com
10BQ015	International Rectifier www.irf.com

Table 6. Recommended Rectifying Diodes

Output Current Programming

The SC4505 features two independent LED current regulators. The LED current setpoints are chosen using external resistors. The relationships between the programming resistors and the two channel output current setpoints are shown as in the Figure 2 and Figure 3 below.

The relationships between the programming resistor value and the output current setpoint can be described as follows:

$$R_{O1SET} = (140 \text{ V}) / I_{O1}$$

$$R_{O2SET} = (154 \text{ V}) / I_{O2}$$

Where R_{O1SET} and R_{O2SET} are in Ohms. I_{O1} and I_{O2} are in Amperes.

I_{O1SET} Resistor Selection Chart

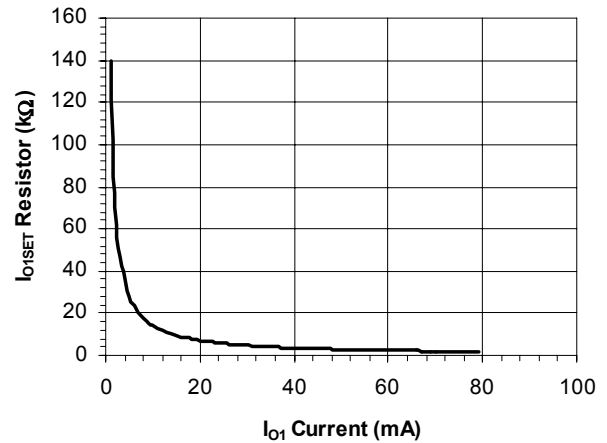

Figure 2. I_{O1SET} Resistor Selection Chart

I_{O2SET} Resistor Selection Chart

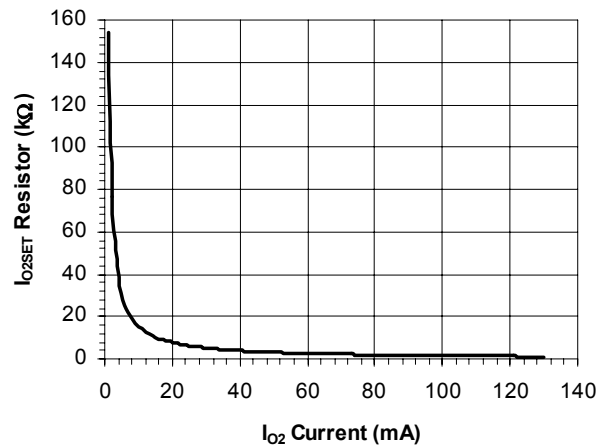

Figure 3. I_{O2SET} Resistor Selection Chart

PWM Dimming

Either of the enable pins can be toggled by external circuitry to allow PWM dimming. In a typical application, a microcontroller sets a register or counter that varies the pulsewidth on a GPIO pin. The SC4505 allows dimming over two decades in frequency (50Hz-50 kHz) in order to allow compatibility with a wide range of devices, including newest dimming strategies that avoid the audio band by using high frequency PWM dimming. In this manner, a wide range of illumination can be generated while keeping the instantaneous LED current at its peak value for luminescent efficiency and color purity. Furthermore, advanced lighting effects such as backlight “dim-on” or photographic red-eye reduction can be implemented as the SC4505 can resolve PWM from 12% to 90% duty at 32kHz.

POWER MANAGEMENT

Applications Information

An additional advantage of PWM dimming comes to customers who prefer to avoid inrush currents when filling the boost output capacitor – simply PWM the device at 12% duty for a millisecond or two, reducing inrush current to less than 50mA. This dim time will vary based on number of LED and size of output capacitor, but can be easily determined on the bench, and programmed into the uC firmware.

For an example, suppose the current flowing through the I_{O1} channel is programmed at 20mA by R_{O1SET}. A 1kHz PWM signal with the duty ratio of 20% is applied to the EN_BL pin of the SC4505. Then the average current flowing through the I_{O1} channel is

$$I_{O1AVG} = 20\% \times 20mA = 4mA$$

A startup delay time between the enable signal goes high and the internal current regulator actually turns on is about 1.6µs, which causes a small offset dependent on PWM frequency. As the PWM signal frequency goes higher, the effect of the delay will get more obvious to customers.

However, since PWM is always linear, offset can be easily corrected in software. The offset correction factor can be described as:

$$D_{CORRECTION} = 100 \times 1.6 \mu S \times F_{PWM}$$

F_{PWM} is in KHz.

For an example, at 20kHz, D_{CORRECTION} = 3%. So for 50% of the nominal LED current in I_{O1} channel, the PWM signal should have a duty ratio of 53%.

Flash Timeout Programming

When Channel IO2 is in flash mode, a timer is available to prevent LED overstress. The timer is only active in Flash mode – not active in torch mode. The capacitor tied between the FTO pin and the AGND sets the time duration of the flash mode. In flash mode, an external capacitor is charged with 1.2µA. When the voltage on this capacitor reaches the 1.25V threshold Channel 2 is turned off. The timer can be reset by entering torch mode or turning off channel 2. The FTO pin can simply be grounded to disable this feature, as would be necessary when using I_{O2} for sub display.

The relationship between the EN_FL, FL_TRB, FTO pin voltage and the current flowing through the IO2 pin is illustrated in Figure 4 below.

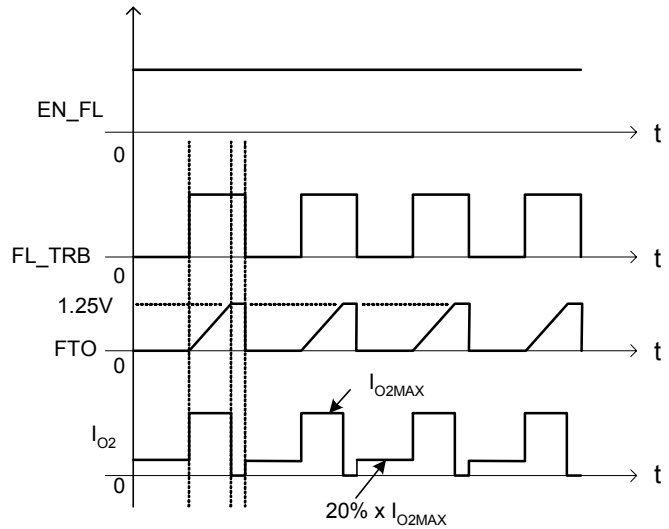

Figure 4. Relationship between RN_FL, FL_TRB, FTO and I_{O2} Current

To calculate the FTO capacitor needed for a desired timeout, a simple formula can be used as shown below:

$$C = 0.862 \cdot 10^{-6} \cdot t$$

Where C is in Farads, and t is in Seconds.

Over Voltage Protection (OVP)

SC4505 includes a built-in overvoltage protection circuit to prevent damage to the IC and output capacitor in the event of open-circuit condition. The output voltage of the boost converter is detected at the VO pin, and divided down by an internal resistor strand of 500kΩ. If the voltage at the VO pin exceeds 28V, the boost converter will be shut down, and a strong pulldown will be applied to the VO pin to quickly discharge the output capacitor. This additional level of protection prevents a condition where the output capacitor and Schottky diode must endure high voltage for an extended period of time, which can pose a reliability risk for the user’s system.

The boost OVP triggering point can be adjusted by adding an external resistor divider at VO pin as shown in Figure 5.

POWER MANAGEMENT

Applications Information

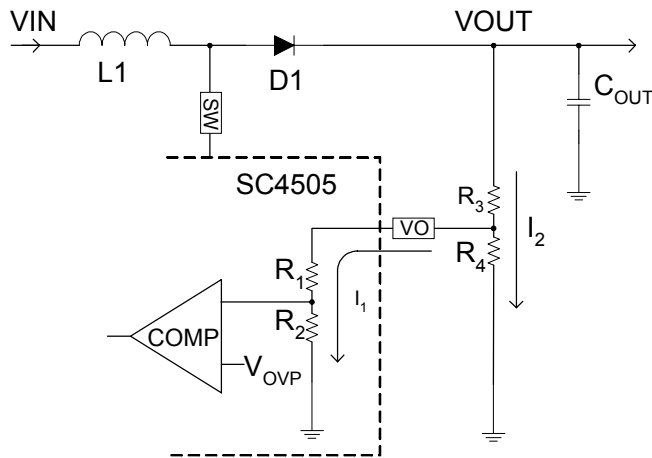

Figure 5. OVP Tweak

As shown in Figure 5, R_1 and R_2 are the internal resistor divider. R_3 and R_4 are external resistor divider for OVP triggering point adjustment. It is noted that the resistance of the internal resistor divider formed by R_1 and R_2 is around $500k\Omega$. When OVP happens, a strong pulldown will be applied to VO pin to quickly discharge the output capacitor. Any large value of R_3 will slow down the discharge process at OVP condition. Generally speaking, small value of R_3 is preferred in applications.

However, small value of the resistor divider formed by R_3 and R_4 would cause additional power loss. People often use $R_4=100k\Omega$ and then select R_3 according to the OVP specification. In this case, the OVP triggering threshold estimation equation can be rewritten as follows:

$$V_{OVP} = \frac{R_4 // 500K\Omega + R_3}{R_4 // 500K\Omega} \times 28V$$

Set

$$R_4 = 100K\Omega$$

We can get

$$R_3 = \left(\frac{V_{OVP}}{28V} - 1 \right) \times 83.3K\Omega$$

The tolerance of the R_3 and R_4 should also be considered in determining the OVP triggering point. Usually there is about 5%~8% difference between the calculated value and the measure OVP triggering threshold.

POWER MANAGEMENT

Applications Information

Layout Guideline

The SC4505 contains a boost converter. The placements of the power components outside the SC4505 should follow the guideline of general boost converter layout. The application circuit (Figure 7a) will be used as an example. The layout illustration diagram is shown as in Figure 6a and Figure 6b.

As shown in Figure 6a, C1 serves as decoupling capacitor for the SC4505. It should be placed close to the VIN and PGND of SC4505 to achieve the best performance. C2 is the input power filtering capacitor for the boost converter power train. L1 is the boost converter input inductor. D5 is the output rectifying diode. It is recommended that a schottky diode is used for fast reverse recovery.

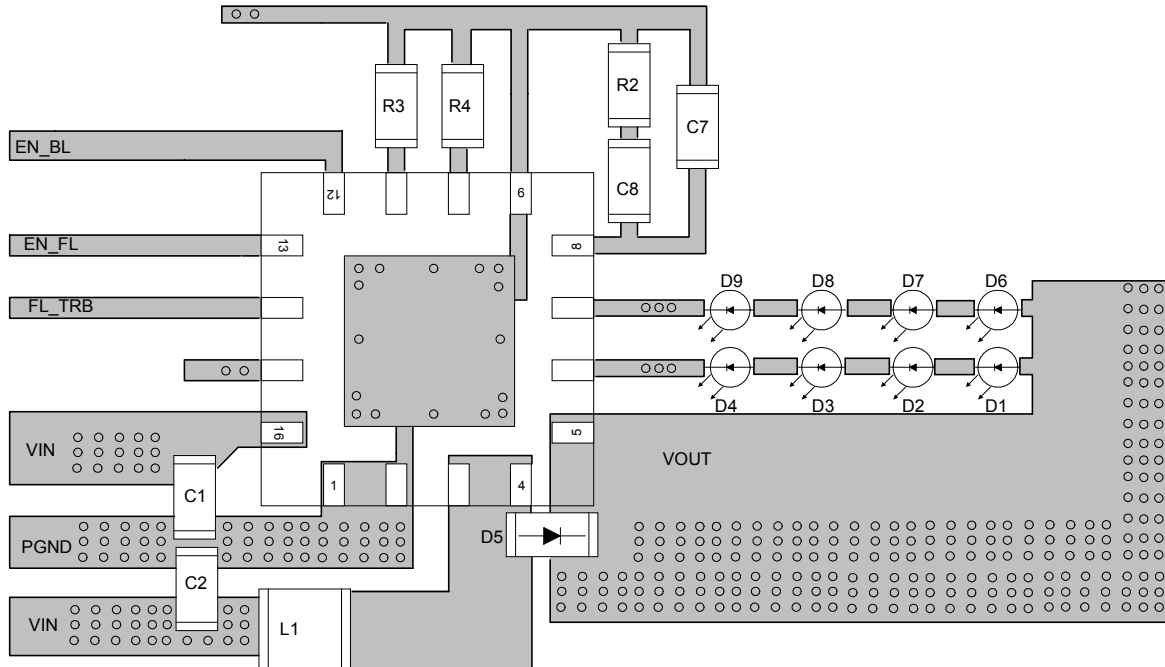

Figure 6a Layout Illustration -- Top Layer

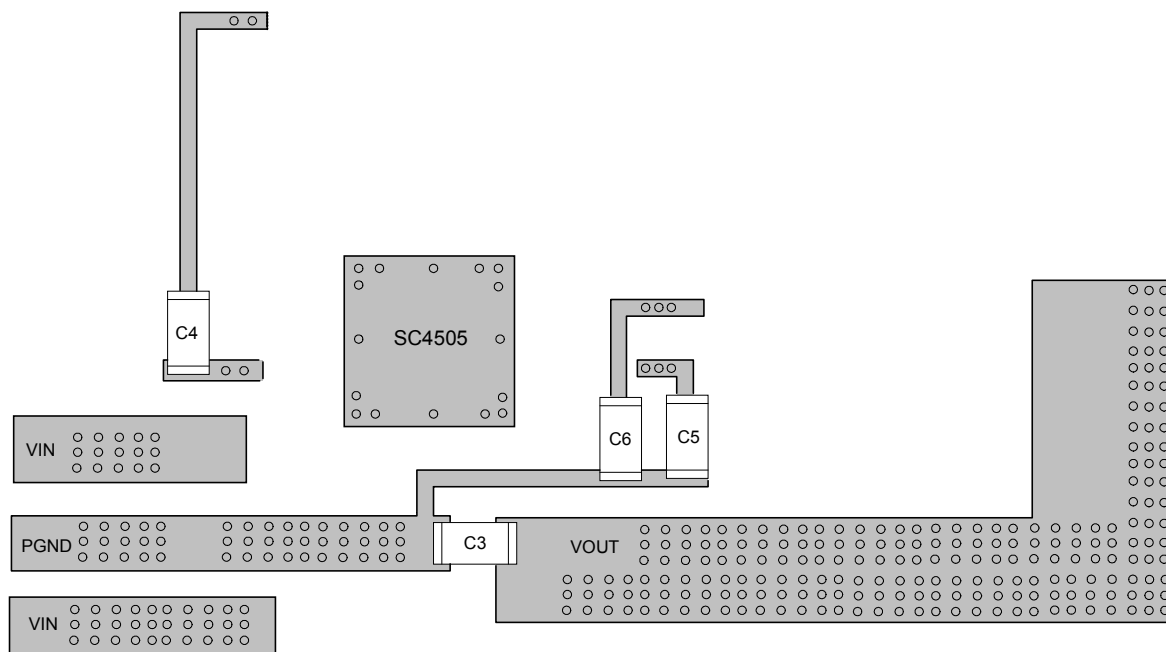

Figure 6b Layout Illustration -- Bottom Layer

POWER MANAGEMENT

Applications Information

To minimize switching noise for boost converter, the output capacitor, C3, should be placed right at the bottom as displayed in Figure 6b so that loop formed by C3, D5 and the SC4505 internal switch is the smallest. The output of the boost converter is used to power up the LEDs. The backlight LED string includes D6, D7, D8 and D9. The flashlight/torch-light string is composed of D1, D2, D3 and D4. C5 and C6 are the filtering capacitors for the IO2 and IO1 pins and they are optional to customers. If they are adopted, C5 should be placed as close as possible to IO2 and PGND and C6 should be placed as close as possible to IO1 and PGND. R2, C7 and C8 form the compensation network for the boost converter. C7 should return to analog ground. C4, on the bottom layer, determines the flash timeout duration. It should be connected to analog ground. R3 and R4 are the output current programming resistors for I_{01} and I_{02} respectively. R3 and R4 should return to analog ground.

Since there is pad at the bottom of the SC4505 for heat dissipation, as shown in Figure 6a, a copper area right underneath the pad is used for better heat spreading. On the bottom layer of the board, another square copper area, connected through vias to the top layer, is used for better thermal performance. The pad at the bottom of the SC4505 should be tied to the analog ground of the SC4505. The analog ground should be kelvin connected to the power ground near the input filtering capacitors for better noise immunity as shown in Figure 6a.

POWER MANAGEMENT

Typical Application Circuits

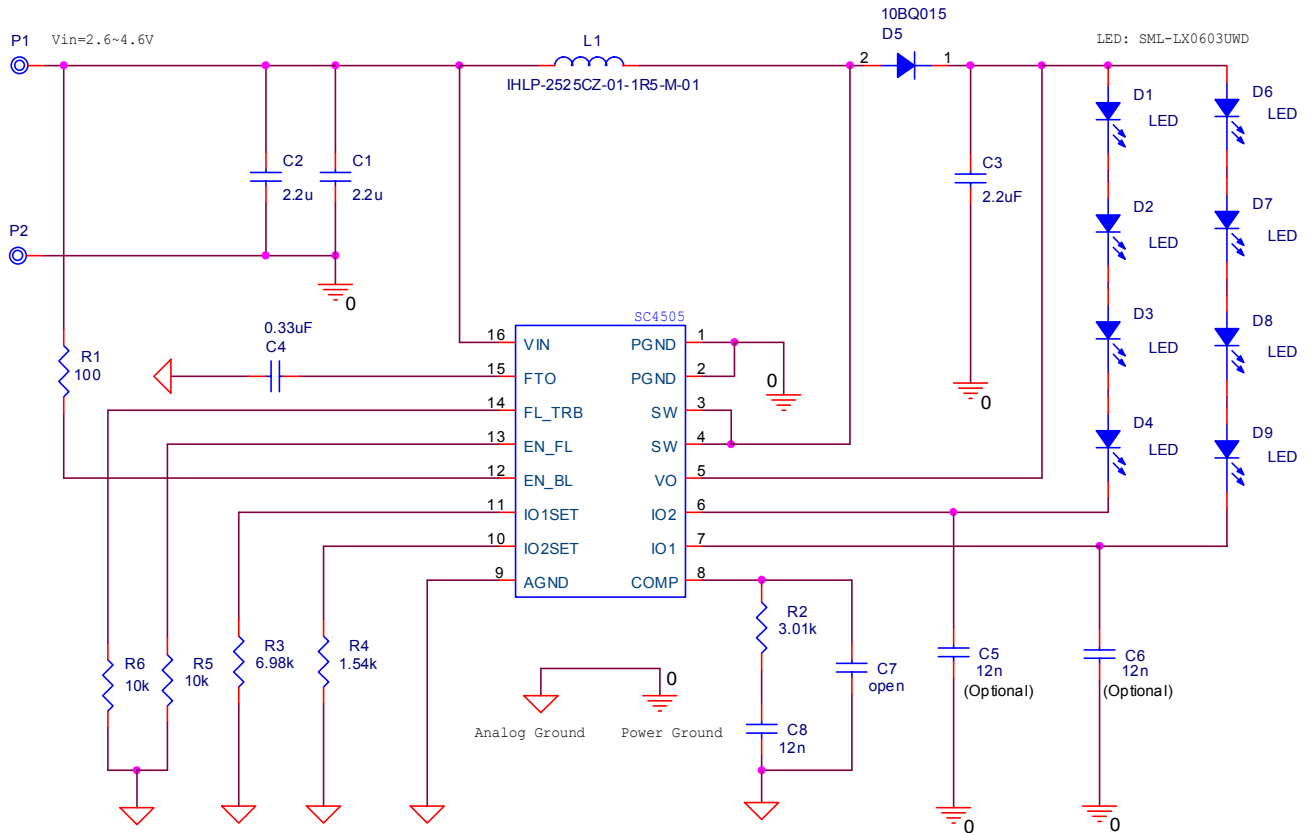

Figure 7a Backlight and Flashlight LED driver for $I_{O1}=20\text{mA}$ and $I_{O2}=100\text{mA}$

Boost Converter Efficiency vs Input Voltage
(Backlight Mode: 4 LEDs @ $I_{O1}=20\text{mA}$)

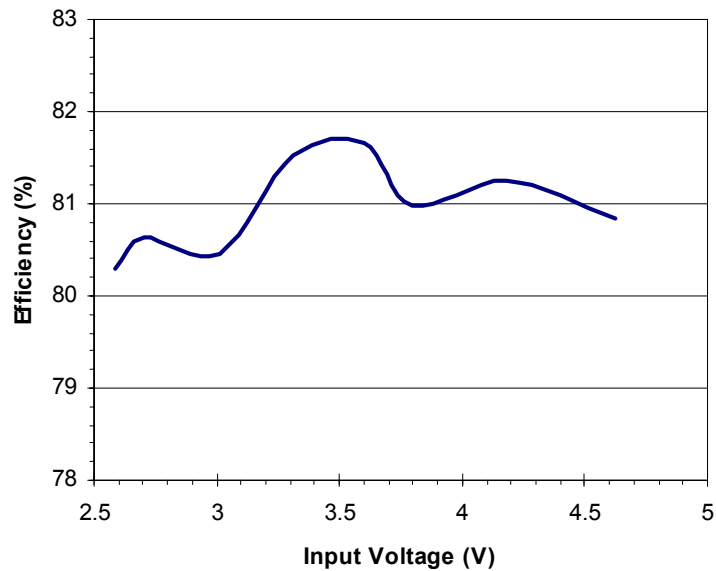
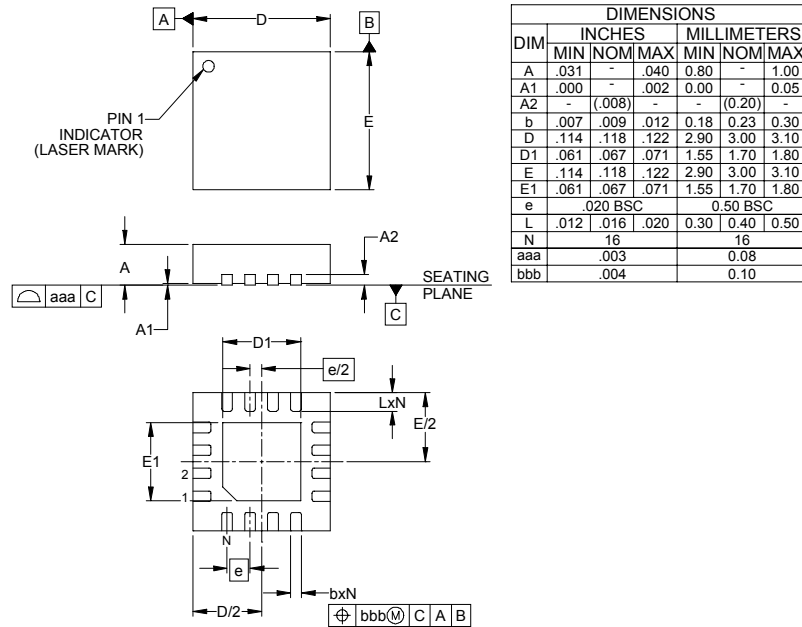

Figure 7b Efficiency Curve for Backlight LEDs Driver Application

POWER MANAGEMENT

Outline Drawing - MLPQ - 16



- NOTES:
1. CONTROLLING DIMENSIONS ARE IN MILLIMETERS (ANGLES IN DEGREES).
 2. COPLANARITY APPLIES TO THE EXPOSED PAD AS WELL AS THE TERMINALS.
 3. DAP IS 1.90 x 1.90mm.

Land Pattern - MLPQ - 16

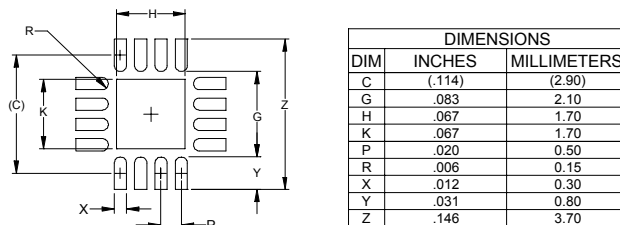

- NOTES:
1. THIS LAND PATTERN IS FOR REFERENCE PURPOSES ONLY. CONSULT YOUR MANUFACTURING GROUP TO ENSURE YOUR COMPANY'S MANUFACTURING GUIDELINES ARE MET.
 2. THERMAL VIAS IN THE LAND PATTERN OF THE EXPOSED PAD SHALL BE CONNECTED TO A SYSTEM GROUND PLANE. FAILURE TO DO SO MAY COMPROMISE THE THERMAL AND/OR FUNCTIONAL PERFORMANCE OF THE DEVICE.

Contact Information

Semtech Corporation
 Power Management Products Division
 200 Flynn Road, Camarillo, CA 93012
 Phone: (805)498-2111 FAX (805)498-3804