



Chipsmall Limited consists of a professional team with an average of over 10 year of expertise in the distribution of electronic components. Based in Hongkong, we have already established firm and mutual-benefit business relationships with customers from,Europe,America and south Asia,supplying obsolete and hard-to-find components to meet their specific needs.

With the principle of “Quality Parts,Customers Priority,Honest Operation,and Considerate Service”,our business mainly focus on the distribution of electronic components. Line cards we deal with include Microchip,ALPS,ROHM,Xilinx,Pulse,ON,Everlight and Freescale. Main products comprise IC,Modules,Potentiometer,IC Socket,Relay,Connector.Our parts cover such applications as commercial,industrial, and automotives areas.

We are looking forward to setting up business relationship with you and hope to provide you with the best service and solution. Let us make a better world for our industry!



## Contact us

Tel: +86-755-8981 8866 Fax: +86-755-8427 6832

Email & Skype: info@chipsmall.com Web: www.chipsmall.com

Address: A1208, Overseas Decoration Building, #122 Zhenhua RD., Futian, Shenzhen, China



### POWER MANAGEMENT

#### Description

The SC453 IC is a single chip high-performance Hysteretic PWM controller. With its integrated SmartDrive™ it powers advanced graphics and core processors. It provides sleep mode and boot voltage support. Automatic power-save is present to prevent negative current flow in the low-side FET during light loading conditions saving even more power. The high side driver initially turns on with a weak drive to reduce ringing, EMI, and capacitive turn-on of the low side.

A 6-bit DAC (accurate to 0.85%) sets the output voltage reference and implements the 0.700V to 1.708V range required by the processor. The hysteretic converter uses a comparator without an error amplifier to provide fast transient response while avoiding the stability issues inherent to classical PWM controllers. The DAC is externally slew rate limited to minimize transient currents and audible noise.

The SC453 operates from a 5V supply and also features soft-start, an open-drain power good signal with  $V_{CORE}$  transition blanking, and an enable input. Programmable current limiting shuts down the SC453 after 32 current limit pulses.

#### Features

- ◆ High Speed Hysteretic Controller
- ◆ Single Phase Operation
- ◆ Selectable Analog or VID Controlled Sleep Setting
- ◆ 6 Bit VID programmable Output
- ◆ Integrated Drivers with SmartDrive™
- ◆ Programmable Soft-Start
- ◆ Programmable Boot Voltage
- ◆ Programmable Sleep Voltage with Sleep Mode
- ◆ Under-Voltage Lockout on  $V_{CCA}$  and  $V_5$
- ◆ Over-voltage Protection on  $V_{CORE}$
- ◆ Current Limit Protection on  $V_{CORE}$
- ◆ Thermal Protection
- ◆ Power Good Flag with Blanking During  $V_{CORE}$  Changes
- ◆ Automatic Power Save at Light Load
- ◆ Package Types — TSSOP-28, MLPQ-32

#### Applications

- ◆ Low Power Notebook and Laptop Computers
- ◆ Embedded Applications

PowerStep IV™ and Smart Driver™ are trademarks of Semtech Corporation.

#### Typical Application Circuit

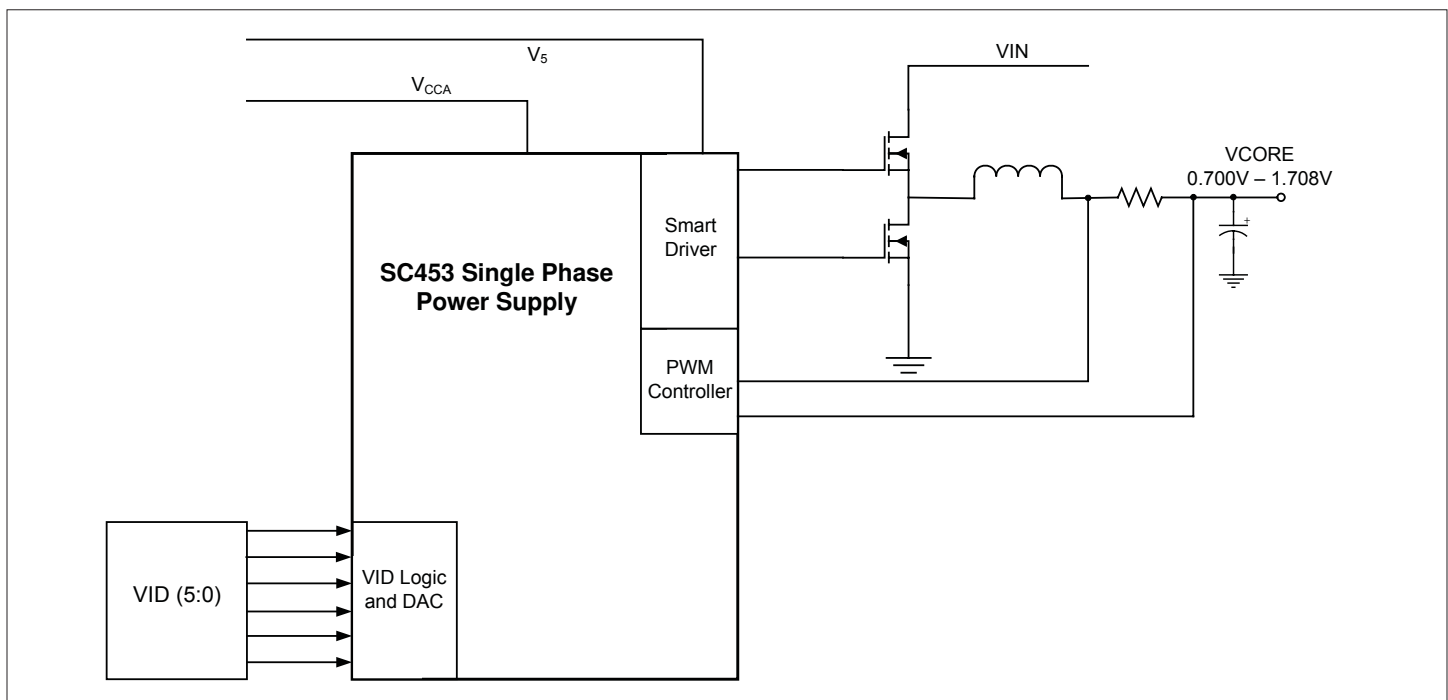

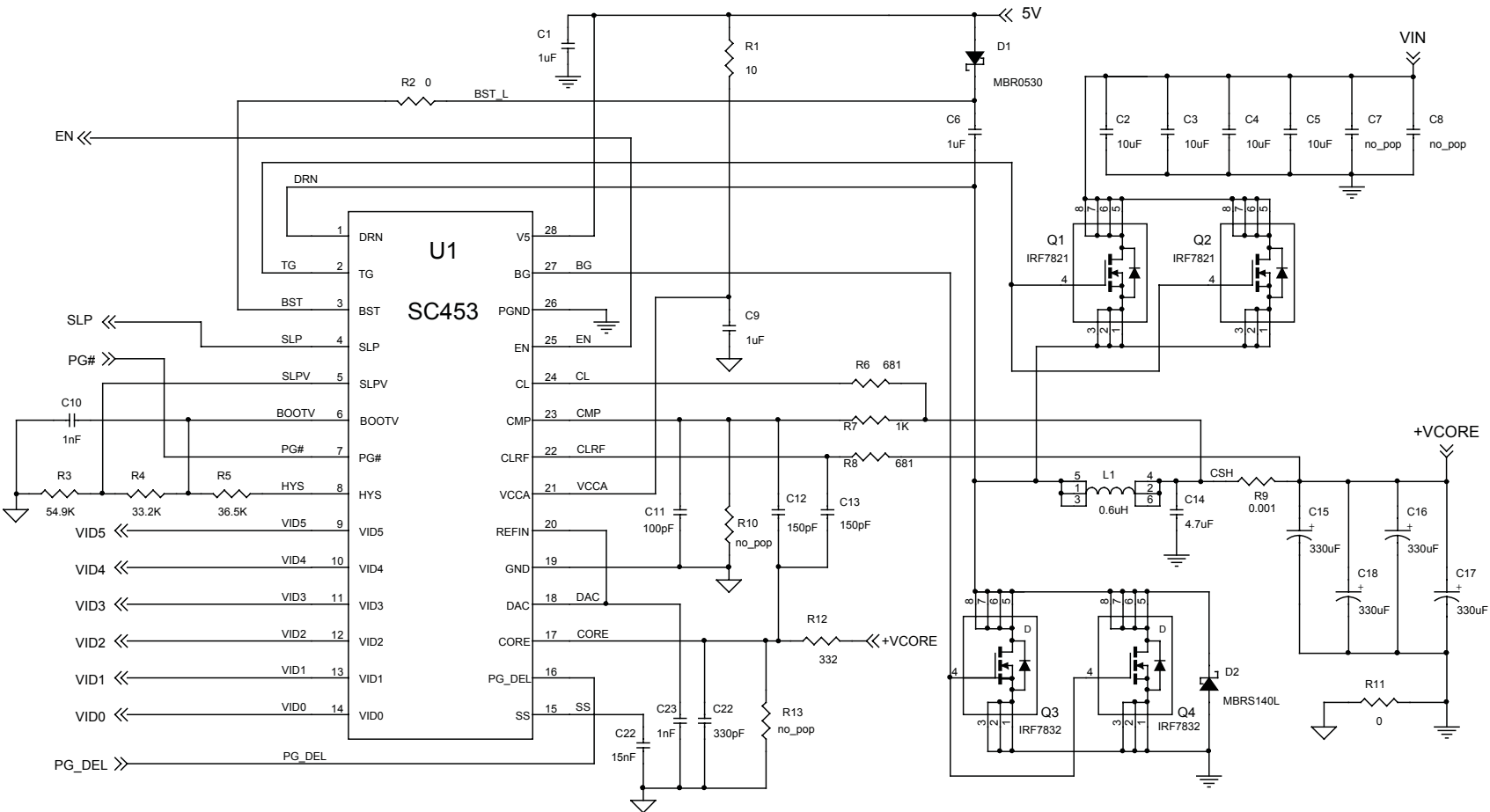
**POWER MANAGEMENT**  
**Reference Design**

**POWER MANAGEMENT**
**Absolute Maximum Ratings**

Exceeding the specifications below may result in permanent damage to the device or device malfunction. Operation outside of the parameters specified in the Electrical Characteristics section is not implied.

Parameter	Symbol	Conditions	Min	Max	Units
Supply Voltages	$V_{CCA}, V_5$		-0.3	7	V
Input and Output Voltages	$V_{SLPV}, V_{SLP}, V_{VID [0..5]}, V_{DAC}, V_{REFIN}, V_{CMP}, V_{HYS}, V_{CORE}, V_{CL}, V_{CLR}, V_{CLR}, V_{PG\#}, V_{BOOTV}, V_{SS}, V_{BG}, V_{CLSET}$	to GND	-0.3	$V_{CCA} + 0.3$	V
EN to GND	$V_{EN}$		-0.3	7	V
BST to PGND		Static Transient < 100ns	-0.3	36 40	V V
BST to DRN			-0.3	7	V
DRN to PGND		Static Transient < 100ns Transient < 10ns	-2 -5 -7.5	30 34 34	V V V
TG to BST			-0.3	BST + 0.3	V
PGND to GND			-0.3	0.3	V
Thermal Resistance Junction to Ambient	$\theta_{JA}$	TSSOP-28 <sup>(1)</sup> MLPQ-32		70 26	°C/W
Thermal Resistance Junction to Case	$\theta_{JC}$	TSSOP-28		20	°C/W
Lead Temperature (Soldering) 10s	$T_{LEAD}$	TSSOP-28		300	°C
Peak IR Reflow Temperature 10 - 40s	$T_{PKG}$	TSSOP-28 MLPQ-32		260 260	°C

**NOTES:**

(1) Calculated from package in still air, mounted to 3 x 4.5(in), 4 layer FR4 PCB.

(2) Tested according to JEDEC standard JESD22-A114.

**Electrical Characteristics**

Unless otherwise specified:  $V_{IN} = 15V, V_{CCA} = 5V,$  and  $V_5 = 5V.$

Parameter	Symbol	Conditions	Min	Typ	Max	Units
<b>Supply (<math>V_{IN}, V_{CCA}, V_5</math>)</b>						
$V_{IN}$ Supply Voltage Range	$V_{IN}$		3.0		25	V
$V_5$ Supply Voltage Range	$V_5$		4.3	5.0	6.0	V
$V_{CCA}$ Voltage Range	$V_{CCA}$		4.5	5.0	6.0	V

**POWER MANAGEMENT**
**Electrical Characteristics (Cont.)**

Parameter	Symbol	Conditions	Min	Typ	Max	Units	
$V_{CCA}$ Quiescent Current	$I_{CCQ}$	EN is low			10	$\mu$ A	
		EN is high, $V_{CCA}$ or $V_5$ in UVLO		400		$\mu$ A	
$V_{CCA}$ Operating Current	$I_{CC}$			5		mA	
<b>Under-Voltage Lockout Circuits (<math>V_{CCA}</math>, <math>V_5</math>)</b>							
Threshold ( $V_{CCA}$ falling)	$V_{HCCA}$		3.47	3.70	3.93	V	
$V_{CCA}$ Hysteresis	$V_{HYST CCA}$			190		mV	
Threshold ( $V_5$ falling)	$V_{HV5}$		3.85	4.00	4.25	V	
$V_5$ Hysteresis	$V_{HYST V5}$			210		mV	
<b>Fixed Over-Voltage Protection (CORE)</b>							
Threshold (CORE Rising)	$V_{TH CORE FIXED}$	Not dependent on DAC setting	1.95	2.00	2.05	V	
<b>Enable Input (EN)</b>							
Input High	$V_{IH (EN)}$		2			V	
Input Low	$V_{IL (EN)}$				0.8	V	
<b><math>V_{CORE}</math> Power Good Generator (PG_DEL, PG#)</b>							
Core Input Threshold	$V_{TH CORE}$	$V_{DAC} = 0.6 - 1.75V$ Note: during UVLO, the output level of this signal is undefined	Upper Threshold	$1.1 \times V_{DAC}$		$1.15 \times V_{DAC}$	V
			Lower Threshold	$0.86 \times V_{DAC}$		$0.9 \times V_{DAC}$	
			Hysteresis		1		
PG# Output Voltage	$V_{PG\#}$	Pulled up with external 680 $\Omega$ resistor to $V_{PULL-UP}$	$V_{CORE} = V_{DAC}$			0.4	V
			Either $V_{CORE} < 0.88 \times V_{DAC}$ , or, $V_{CORE} > 1.12 \times V_{DAC}$	$0.95 \times V_{PULL-UP}$			
			$V_{CCA}$ or $V_5$ in UVLO	$0.95 \times V_{PULL-UP}$			
PG_DEL Output Voltage	$V_{PG\_DEL}$	$V_{CORE} = V_{DAC}$ , PG_DEL pulled-up with external 680 $\Omega$ resistor to $V_{PULL-UP}$		$0.95 \times V_{PULL-UP}$			V
			$V_{CORE} < 0.88 \times V_{DAC}$ or $V_{CORE} > 1.12 \times V_{DAC}$			0.4	
			$V_{CCA}$ or $V_5$ in UVLO			0.8	
PG_DEL Delay (at start-up)		Measured from PG# assertion		1007		Clocks	

**POWER MANAGEMENT**
**Electrical Characteristics (Cont.)**

Parameter	Symbol	Conditions	Min	Typ	Max	Units
<b>Soft-Start &amp; DAC Slew (SS)</b>						
Soft-Start/DAC Slew Current  Note: SS cap is not discharged until EN goes low or UVLO cuts in. To enable the converter, SS has to drop below $V_{SS\_EN}$ .	$I_{SS}$	Discharge (sink) Current	5	10		mA
		Soft-Start transition $0 < T_A < 85^\circ\text{C}$ , $-40 < T_A < 85^\circ\text{C}$	7.5	10.5	16	$\mu\text{A}$
		Sleep Exit, $0 < T_A < 85^\circ\text{C}$	204	256	310	
		Sleep Exit, $-40 < T_A < 85^\circ\text{C}$	180	240	320	
		VID Transition, $0 < T_A < 85^\circ\text{C}$	102	128	155	
		VID Transition, $-40 < T_A < 85^\circ\text{C}$	90	120	160	
Soft-Start Enable Threshold	$V_{SS\_EN}$			40	100	mV
<b>DAC (VID [5:0])</b>						
VID Input Threshold	$V_{iH\_VID}$		0.55			V
	$V_{iL\_VID}$				0.45	
DAC Output Voltage Accuracy	$V_{DAC\_ERR}$	$0^\circ < T_A < 85^\circ\text{C}$ , VID [5:0] = 000000 - 111111 (1.708V - 0.812V)	-0.85		+0.85	%
		$-25^\circ\text{C} < T_A < 85^\circ\text{C}$ , VID [5:0] = 000000 - 111111 (1.708V - 0.700V)	-2.0		+2.0	%
<b>Boot Voltage (BOOTV)</b>						
Input Voltage Offset	$V_{BOOTV} - V_{DAC}$	BOOTV = 1.2V			$\pm 3$	%
BOOT Delay Time <sup>(1)</sup>	TBOOT		10	35		$\mu\text{s}$
<b>Sleep (SLP, SLPV)</b>						
Input Voltage Offset	$V_{SLPV} - V_{DAC}$	SLPV = 0.8V			$\pm 3$	%
SLP Logic Threshold	$V_{iH\_SLP}$		2			V
	$V_{iL\_SLP}$				0.8	
<b>CORE Comparator (CMP, REFIN, HYS)</b>						
Input Bias Current	$I_{REFIN}$	$V_{REFIN} = 1.3\text{V}$			$\pm 2$	$\mu\text{A}$
Input Voltage Offset	$V_{CMP} - V_{REFIN}$			$\pm 1.5$	$\pm 3$	mV

**POWER MANAGEMENT**
**Electrical Characteristics (Cont.)**

Parameter	Symbol	Conditions	Min	Typ	Max	Units	
<b>CORE Comparator (CMP, REFIN, HYS) (Cont.)</b>							
Hysteresis Setting Current SLP = low	$I_{CMP}$	$R_{HYS} = 17K$	$V_{CMP} < V_{REFIN}$	-110	-100	-90	$\mu A$
			$V_{CMP} > V_{REFIN}$	90	100	110	
		$R_{HYS} = 170K$	$V_{CMP} < V_{REFIN}$	-7	-10	-13	
			$V_{CMP} > V_{REFIN}$	7	10	13	
Hysteresis Setting Current SLP = high	$I_{SLP\_CMP}$	$R_{HYS} = 17K$	$V_{CMP} < V_{REFIN}$	-83	-73	-63	$\mu A$
			$V_{CMP} > V_{REFIN}$	63	73	83	
<b>Current Limit Comparator (CL, CLRF, HYS)</b>							
Input Bias Current	$I_{CL}$	$V_{CL1,2} = 1.3V$			$ \pm 2 $	$\mu A$	
Input Voltage Offset	$V_{CL} - V_{CLRF}$			$ \pm 3 $	$ \pm 5 $	mV	
Current Limit Setting Current SLP = low	$I_{CLRF}$	$R_{HYS} = 17K$	$V_{CL} < V_{CLRF}$	150	200	250	$\mu A$
			$V_{CL} > V_{CLRF}$	250	300	350	
		$R_{HYS} = 170K$	$V_{CL} < V_{CLRF}$	15	20	25	
			$V_{CL} > V_{CLRF}$	25	30	35	
Current Limit Setting Current SLP = high	$I_{SLP\_CLRF}$	$R_{HYS} = 17K$	$V_{CL} < V_{CLRF}$	120	150	180	$\mu A$
			$V_{CL} > V_{CLRF}$	195	230	265	
<b>Zero-Crossing (Powersave) Comparators (CL, CORE)</b>							
Offset	$V_{CL} - V_{CORE}$				$ \pm 5 $	mV	
<b>High Side Driver (TG)</b>							
Peak Output Current <sup>(1)</sup>	$I_{pkh}$			1.5		A	
Output Resistance	$R_{SRC\_TG}$	$I = 100mA,$ $V_{BST} - V_{DRN} = 5V$	$V_{DRN} < 1V$		4.2	$\Omega$	
			$V_{DRN} > 1V$		1		4
	$R_{SINK\_TG}$	$I = 100mA, V_{BST} - V_{DRN} = 5V$			0.7	1.4	$\Omega$
Rise Time <sup>(1)</sup>	$tr_{TG}$	$C_{TG} = 3nF, V_{BST} - V_{DRN} = 5V$			60		ns
Fall Time <sup>(1)</sup>	$tf_{TG}$	$C_{TG} = 3nF, V_{BST} - V_{DRN} = 5V$			36		ns

**POWER MANAGEMENT**
**Electrical Characteristics (Cont.)**

Parameter	Symbol	Conditions	Min	Typ	Max	Units
<b>High Side Driver (Cont.)</b>						
Propagation Delay TG Going High <sup>(1)</sup>	$tpdh_{TG}$	CMP crossing REFIN to 10% point of TG, $C_{TG} = 3nF$ , $BG = 0V$		45		ns
Propagation Delay TG Going Low <sup>(1)</sup>	$tpdl_{TG}$	CMP crossing REFIN to 90% point of TG, $C_{TG} = 3nF$		45		ns
Shoot-thru Protection Delay Time <sup>(1)</sup>	$tspd$		21	30	39	ns
<b>Low Side Driver (BG)</b>						
Peak Output Current <sup>(1)</sup>	$I_{pkl}$			3		A
Output Resistance	$R_{SRC\_BG}$	$I = 100mA$ , $V5 = 5V$		1.0	2.6	$\Omega$
	$R_{SINK\_BG}$			0.5	1.2	
Rise Time <sup>(1)</sup>	$tr_{BG}$	$C_{BG} = 3nF$ , $V5 = 5V$		25		ns
Fall Time <sup>(1)</sup>	$tf_{BG}$	$C_{TG} = 3nF$ , $V = 5V$		15		ns
Propagation Delay TG Going High <sup>(1)</sup>	$tpdh_{BG}$	CMP crossing REFIN to 10% point of BG, $C_{BG} = 3nF$ , $DRN = 0V$		35		ns
Propagation Delay TG Going Low <sup>(1)</sup>	$tpdl_{BG}$	CMP crossing REFIN to 90% point of TG, $C_{TG} = 3nF$ , $DRN = 0V$		35		ns

Notes:

1) Guaranteed by design.

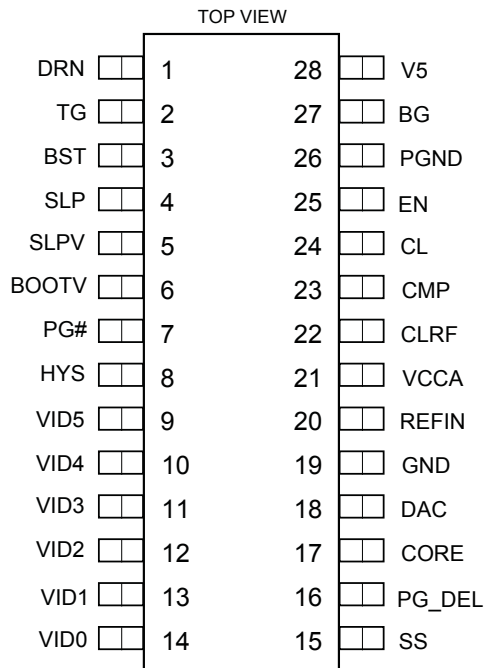

**POWER MANAGEMENT**
**Pin Configurations**

**TSSOP-28 Package**

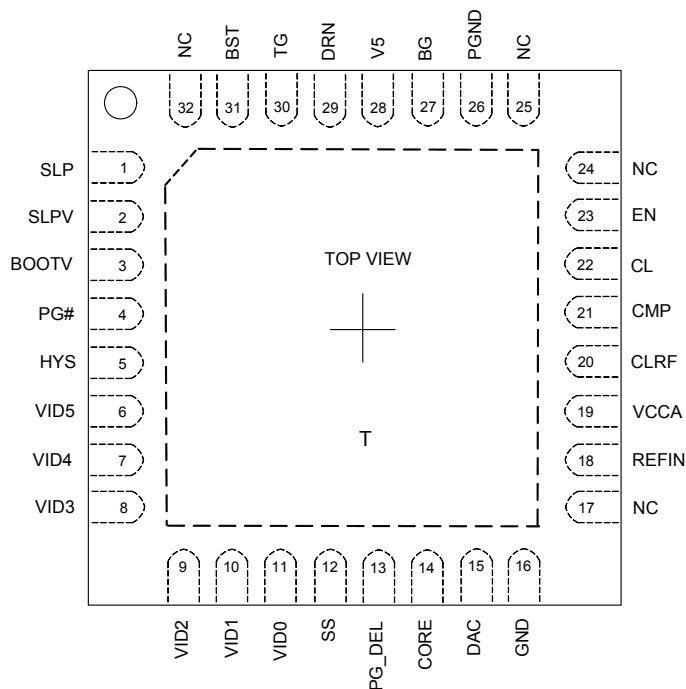
$$\theta_{JA} = 70^{\circ}\text{C/W}$$

**MLPQ-32 Package**

$$\theta_{JA} = 29^{\circ}\text{C/W}$$

**Ordering Information**

Device	Package
SC453TSTRT <sup>(1)(2)(3)</sup>	TSSOP-28
SC453EVB	EVALUATION BOARD
SC453MLTRT <sup>(1)(2)(4)</sup>	MLPQ-32

**Notes:**

1. This device is ESD sensitive. Use of standard ESD handling precautions is required.
2. Lead-free package only. Qualified to support maximum IR reflow temperature of 260°C for 30 seconds.
3. Available in tape and reel only. A reel contains 2500 devices.
4. Available in tape and reel only. A reel contains 3000 devices.

**POWER MANAGEMENT**
**Pin Descriptions**

Pin# TSSOP-28	Pin# MLPQ-32	Pin Name	Pin Function
1	29	DRN	This pin connects to the junction of the switching and synchronous MOSFETs.
2	30	TG	Gate drive for the switching (high-side) MOSFET.
3	31	BST	Bootstrap pin. A capacitor is connected between BST and DRN pins to develop the floating bootstrap voltage for the high-side MOSFET gate drive.
4	1	SLP	Sleep logic input signal.
5	2	SLPV	Connect this pin to $V_{CCA}$ to select VID Sleep Mode. Otherwise, SLPV Sleep Mode is selected and the voltage on this pin sets the DAC output during sleep.
6	3	BOOTV	The voltage on this pin sets the Boot-Up voltage.
7	4	PG#	Start clock indicator open drain output — Active low
8	5	HYS	Core Comparator Hysteresis — Connect to ground through an external resistor. Hysteresis current is established by the internal $V_{REF}$ voltage, 1.7V, divided by the total HYS resistance ( $R_{HYS}$ ).
9	6	VID5	VID input, most significant bit of the voltage programming DAC input
10	7	VID4	VID input
11	8	VID3	VID input
12	9	VID2	VID input
13	10	VID1	VID input
14	11	VID0	VID input, least significant bit of the voltage programming DAC input
15	12	SS	Soft-start — an external cap defines the soft-start ramp.
16	13	PG_DEL	Delayed Power Good — open drain output. After the $V_{CORE}$ output is within $\pm 14\%$ of the VID_DAC setting, and the $t_{CPU\_PWRGD}$ period has terminated, this internal pull-down MOSFET opens and the pin is pulled high by an external resistor.
17	14	CORE	Feedback input for the $V_{CORE}$ output. A small RC filter should be used to filter out high frequency noise to prevent false or faulty trip conditions.
18	15	DAC	Main controller digital-to-analog output
19	16	GND	Analog ground
20	18	REFIN	Core Comparator reference input pin — connect to DAC.
21	19	VCCA	5V supply for precision analog circuitry
22	20	CLRF	Current limit reference input
23	21	CMP	Core Comparator input
24	22	CL	Current limit input

**POWER MANAGEMENT**
**Pin Descriptions (Cont.)**

Pin# TSSOP-28	Pin# MLPQ-32	Pin Name	Pin Function
25	23	EN	Enable input — active high
26	26	PGND	Power ground — connect to the low-side MOSFET power ground
27	27	BG	Gate drive output for the synchronous (low-side) MOSFET
28	28	V5	5V supply input for the gate drive outputs — a 1 $\mu$ F minimum capacitor should be connected from V5 to GND
—	17	NC	No connection
—	24	NC	No connection
—	25	NC	No connection
—	32	NC	No connection
—	T	T	Thermal pad — No internal connection. Connect to GND.

POWER MANAGEMENT

Block Diagram

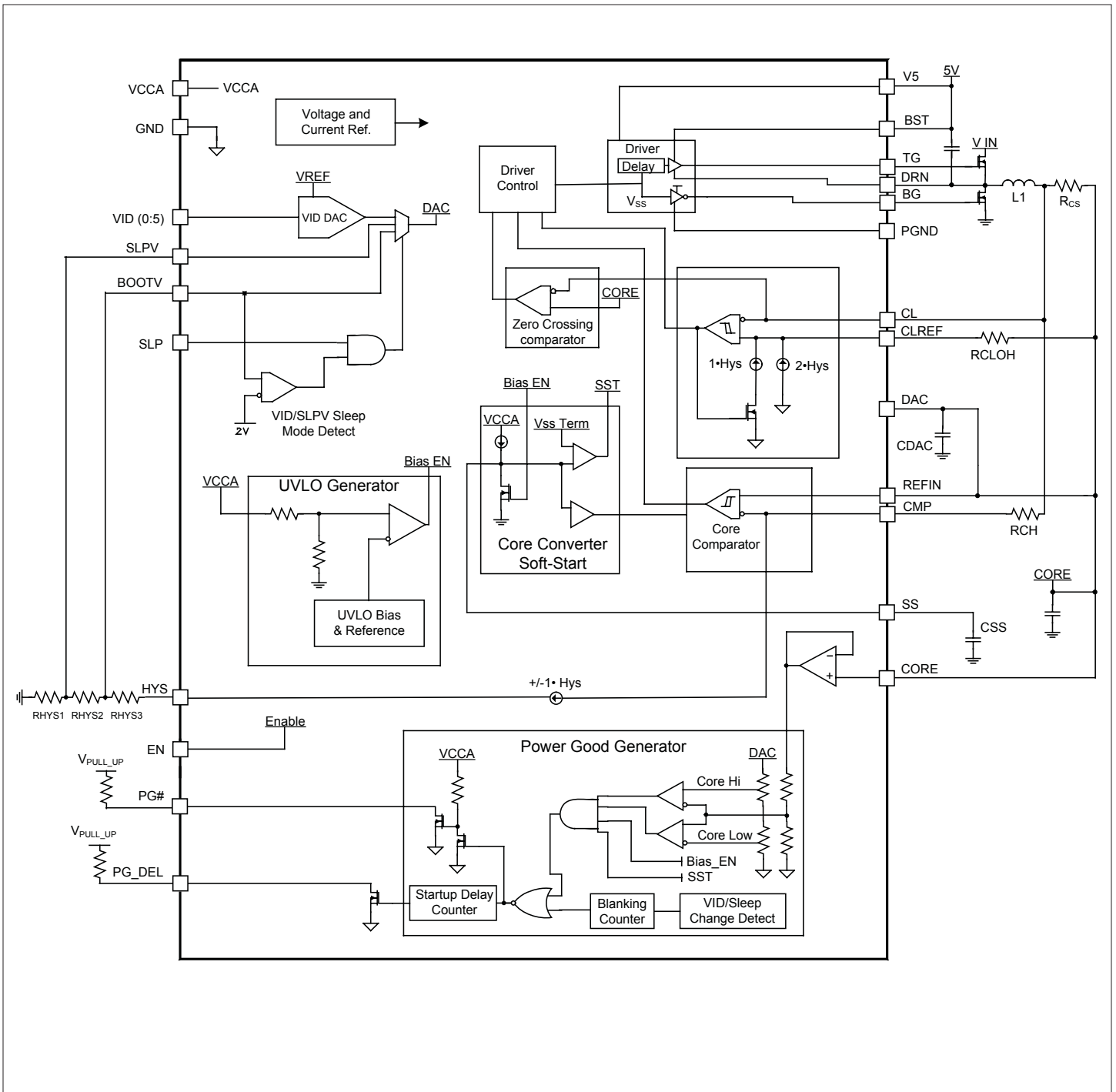

**POWER MANAGEMENT**
**Applications Information (Cont.)**
**SUPPLY, BIAS, UVLO, POWER GOOD GENERATOR**
**Supply**

The chip is optimized to operate from a  $5V \pm 5\%$  rail but also designed to work up to 6V maximum supply voltage.

**Under-Voltage Lock-Out Circuit**

The Under-Voltage Lock-Out (UVLO) circuitry monitors both the VCCA and V5 voltage levels. The SC453 is in UVLO mode while either supply has not ramped above the upper threshold or has dropped below the lower threshold. During UVLO, the external FETs are held off.

**Over-Voltage Protection**

If the CORE voltage is greater than +14% of the DAC (i.e., out of the power good window), the SC453 will latch off and hold the low-side driver on permanently. Either of the 5V supplies or the EN pin must be cycled to clear the latch. The latch is disabled during soft-start and VID/Sleep transitions. For safety, the latch is enabled if the CORE voltage exceeds 2V even during VID/Sleep transitions.

**Thermal Shutdown**

The device will be disabled and latched off when the internal junction temperature reaches approximately 160°C. Either the power or EN must be recycled to clear the latch.

**Band Gap Reference**

A  $\pm 0.85\%$  precision band gap reference acts as the internal reference voltage standard of the chip, which all critical biasing voltages and currents are derived from. All references to  $V_{REF}$  in the equations to follow will assume  $V_{REF} = 1.7V$ .

**Precision DAC**

This 6-bit digital-to-analog converter (DAC) serves as the programmable reference source of the core comparator. Programming is accomplished by logic voltage levels applied to the DAC inputs. The VID code vs. the DAC output is shown in the following table. The accuracy of the VID/DAC is maintained on the same level as the band gap reference.

VID						V <sub>DAC</sub>	VID						V <sub>DAC</sub>
5	4	3	2	1	0	V	5	4	3	2	1	0	V
0	0	0	0	0	0	1.708	1	0	0	0	0	0	1.196
0	0	0	0	0	1	1.692	1	0	0	0	0	1	1.180
0	0	0	0	1	0	1.676	1	0	0	0	1	0	1.164
0	0	0	0	1	1	1.660	1	0	0	0	1	1	1.148
0	0	0	1	0	0	1.644	1	0	0	1	0	0	1.132
0	0	0	1	0	1	1.628	1	0	0	1	0	1	1.116
0	0	0	1	1	0	1.612	1	0	0	1	1	0	1.100
0	0	0	1	1	1	1.596	1	0	0	1	1	1	1.084
0	0	1	0	0	0	1.580	1	0	1	0	0	0	1.068
0	0	1	0	0	1	1.564	1	0	1	0	0	1	1.052
0	0	1	0	1	0	1.548	1	0	1	0	1	0	1.036
0	0	1	0	1	1	1.532	1	0	1	0	1	1	1.020
0	0	1	1	0	0	1.516	1	0	1	1	0	0	1.004
0	0	1	1	0	1	1.500	1	0	1	1	0	1	0.988
0	0	1	1	1	0	1.484	1	0	1	1	1	0	0.972
0	0	1	1	1	1	1.468	1	0	1	1	1	1	0.956
0	1	0	0	0	0	1.452	1	1	0	0	0	0	0.940
0	1	0	0	0	1	1.436	1	1	0	0	0	1	0.924
0	1	0	0	1	0	1.420	1	1	0	0	1	0	0.908
0	1	0	0	1	1	1.404	1	1	0	0	1	1	0.892
0	1	0	1	0	0	1.388	1	1	0	1	0	0	0.876
0	1	0	1	0	1	1.372	1	1	0	1	0	1	0.860
0	1	0	1	1	0	1.356	1	1	0	1	1	0	0.844
0	1	0	1	1	1	1.340	1	1	0	1	1	1	0.828
0	1	1	0	0	0	1.324	1	1	1	0	0	0	0.812
0	1	1	0	0	1	1.308	1	1	1	0	0	1	0.796
0	1	1	0	1	0	1.292	1	1	1	0	1	0	0.780
0	1	1	0	1	1	1.276	1	1	1	0	1	1	0.764
0	1	1	1	0	0	1.260	1	1	1	1	0	0	0.748
0	1	1	1	0	1	1.244	1	1	1	1	0	1	0.732
0	1	1	1	1	0	1.228	1	1	1	1	1	0	0.716
0	1	1	1	1	1	1.212	1	1	1	1	1	1	0.700

## POWER MANAGEMENT

### Applications Information (Cont.)

#### CORE CONVERTER CONTROLLER

##### Core Comparator

This is an ultra-fast hysteretic comparator with a typical propagation delay of 20ns for 20mV overdrive. Hysteresis is generated by the current set at the HYS pin impressed upon an external resistor connected to the CMP pin.

##### Current Limit Comparator

The Current Limit Comparator compares the voltage between the CL and CLREF pins. The CL pin monitors the inductor current using the voltage drop across a resistor connected in series with the inductor. The CLREF voltage determines the upper limit for the Current Limit Comparator. The upper limit is equal to the (3 x HYS) current multiplied by the resistance connected to the CLREF pin.

A current limit condition occurs when the CL voltage exceeds the CLREF voltage, at which point the high side FETs are turned off. The high side FETs will not be enabled again until the inductor current drops below the lower current limit threshold. The upper and lower current limit thresholds are programmed by the voltage drop impressed upon an external resistor connected to the CLREF pin. The voltage drop is equal to the HYS current multiplied by the

##### Current Limit Latch

If the CORE voltage goes lower than 14% below the VID (i.e., out of the power good window), then sustained current limiting (32 current limit pulses) will cause the part to permanently latch off. The latch is inhibited during soft-start.

##### Core Converter Soft-Start Timer

This block controls the start-up ramp time of the CORE voltage up to the boot voltage. The primary purpose is to reduce the initial in-rush current on the core input voltage (battery) rail.

##### Cycle-by-Cycle Power-Save

A zero crossing comparator detects when the currents through the external sense resistor reduces to zero. When the current in the external sense resistor reaches zero, the bottom FET is latched off. The latch is reset when the controller decides to switch on the top FET. This prevents excessive switching at light loads and hence saves switching power losses.

##### DAC Slew Control

The output of the DAC will slew at a rate defined by the current in the SS pin and the capacitor applied externally to the SS pin. The slew rate (charge current) applied depends on which mode (soft-start, VID or sleep transition) is in effect. A 1nF capacitor is recommended for the DAC pin.

##### Blanking During VID Changes

On any VID change or Sleep change, the PG# and PG\_DEL signals are blanked for 62 switching cycles to prevent glitching during the transition.

##### Sleep Function and SLPV/VID Sleep Mode

By default, the controller is in SLPV controlled sleep mode. In this mode, the voltage applied to the SLPV pin appears at the DAC output when SLP is asserted high. This mode is selected by connecting the SLPV to a resistor divider from the HYS pin,

VID sleep mode is selected by connecting the SLPV pin to VCCA during startup. In this mode, the DAC output continues to be set by the VID inputs even when SLP is asserted high.

During sleep mode, the hysteresis current used for PWM switching and for current limit are reduced to 70% of their nominal values.

**POWER MANAGEMENT**

**Applications Information (Cont.)**

**PG# Output**

This is an open-drain output and should be pulled up externally. This signal is asserted (pulled low) by the SC453 whenever the core voltage is within  $\pm 14\%$  of the VID programmed value. If the chip is disabled or enabled in UVLO, then PG# is de-asserted. The signal is forced high (open drain) during VID and sleep transitions.

**PG\_DEL Output**

This signal is delayed a minimum of 3mS from first assertion of the PG# signal. This is an open drain output

and should be pulled up externally. This signal is asserted (open drain) by the SC453 whenever the core is within  $\pm 14\%$  of the VID programmed value. If the chip is disabled or enabled in UVLO, then PG\_DEL is de-asserted. The signal is forced high (open drain) during VID and sleep transitions.

**Start-Up and Sequencing**

On start-up,  $V_{CORE}$  ramps to the boot voltage set by the BOOTV pin irrespective of the status of the VID pins. After a minimum of 10 $\mu$ s, PG# asserts, and  $V_{CORE}$  will then respond to the VID inputs. The controller will then count 1007 switching cycles before asserting PG\_DEL.

**Summary of Fault Conditions**

Protection Mode	Latched?	When Active	Driver Status	SS Pin Status
Supply UVLO (VCCA, V5)	No	Always	All low	Low
32 Cycle Current Limit	Yes	SS has terminated and PGDEL is low	TG low	Sawtooth
114% $V_{CORE}$ OVP	Yes	SS has terminated and PGDEL is low	BG high	High
2.0V $V_{CORE}$ OVP	Yes	Always	BG high	High
Thermal Shutdown	Yes	Always	BG, TG low	High

**Driver Timing Diagram**

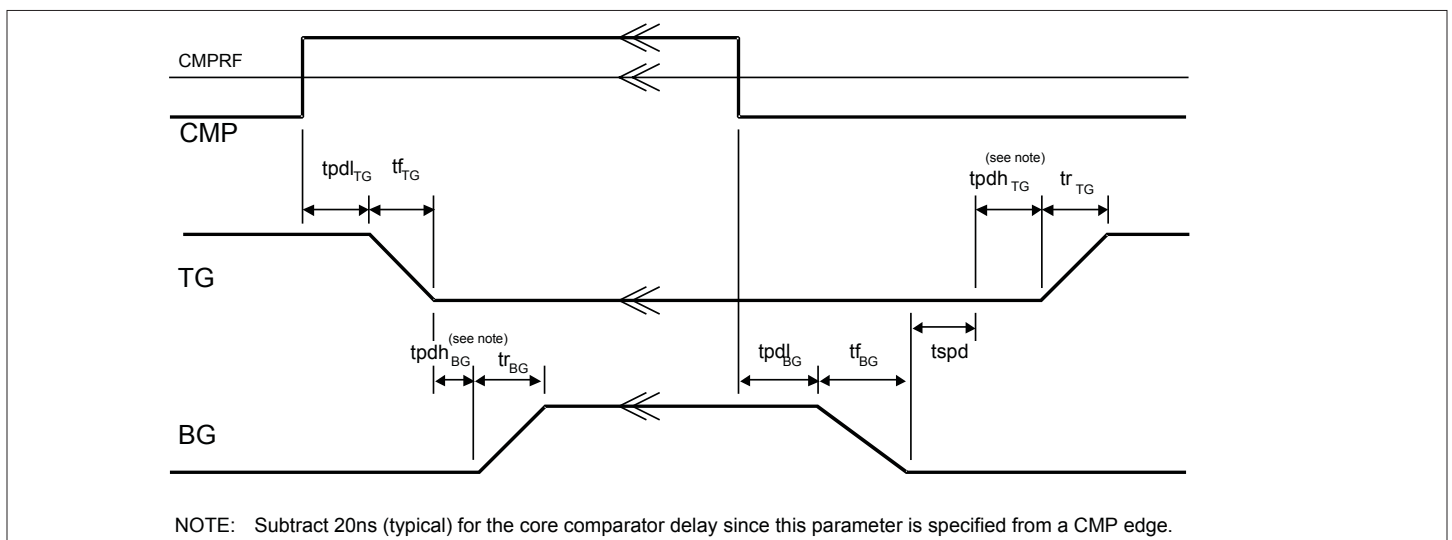

**POWER MANAGEMENT**
**Applications Information (Cont.)**
**DESIGN PROCEDURE**
**Step 1 — Define Constants**

$V_{INMAX} := 20\text{ V}$	Maximum input voltage
$V_{INMIN} := 8\text{ V}$	Minimum input voltage
$I_{MAX\_FL} := 20\text{ A}$	Maximum load current, highest output voltage
$I_{LKGMAX} := 5\text{ A}$	Leakage current, highest output voltage
$V_{MAX\_NL} := 1.212\text{ V}$	The highest $V_{CORE}$ voltage
$V_{MIN\_NL} := 0.956\text{ V}$	The lowest $V_{CORE}$ voltage
$V_{REF} := 1.7\text{ V}$	SC453 Internal reference voltage
$C_{OUT} := 330\text{ }\mu\text{F}$	Output capacitance per cap
$R_{ESR} := 6\text{ m}\cdot\Omega$	ESR per cap
$R_{CS} := 1\text{ m}\cdot\Omega$	Current sense resistor
$R_{CU} := 0.5\text{ m}\cdot\Omega$	Parasitic resistance from the current sense resistor to the processor
$V_{POS\_TRANS} := 50\text{ mV}$	Voltage droop allowed for a low current to high current transient
$V_{NEG\_TRANS} := 50\text{ mV}$	Voltage rise allowed for a high current to low current transient
$V_{RIPPLE} := 20\text{ mV}$	Desired maximum output ripple

**Step 2 — Output Inductor and Capacitor Selection**

The SC453 has passive droop. The voltage at full load is less than the DAC voltage by the voltage drop across the current sense resistor and any PCB copper losses from the sense resistor to the processor socket. The steady-state voltage at full load is as follows.

$$V_{MAX\_FL} := V_{MAX\_NL} - (R_{CS} + R_{CU})I_{MAX\_FL}$$

$$V_{MAX\_FL} = 1.182\text{ V}$$

Output capacitance and ESR values are a function of transient requirements and output inductor value. Figure 1 illustrates the response of a hysteretic converter to a positive transient. In a hysteretic converter with passive droop, like the SC453, two conditions determine if you meet the positive transient requirements.

$$ESR \leq \frac{V_{POS\_TRANS}}{(I_{MAX\_FL} - I_{LKGMAX})}$$

$$V_{NEG\_TRANS} \geq \Delta V(C_{OUT})$$

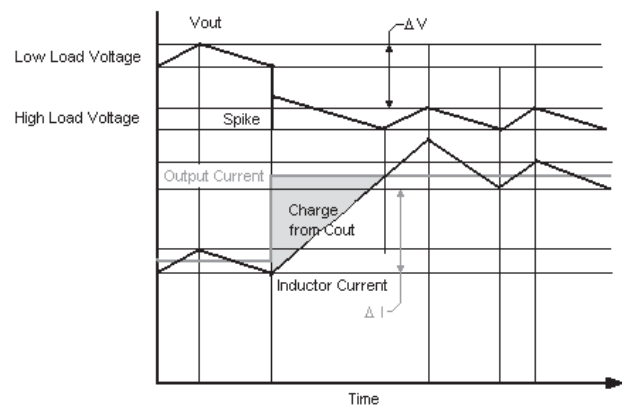

Figure 1 — Hysteretic Converter Response to a Positive Transient

The first condition is easy to see; if the ESR is too high, the instantaneous  $I \cdot ESR$  drop seen at the output will be larger than the allowed limit.



**POWER MANAGEMENT**
**Applications Information (Cont.)**

The second condition occurs later after the initial transient. Due to the fast response of the hysteretic converters, less than  $< 100\text{ns}$ , the capacitor voltage does not droop very far before the inductor current starts ramping up. Once the inductor current starts to rise, the I-ESR component of the capacitor voltage start to move upward. At the same time, the capacitive discharging causes the capacitor voltage to move downward. The lowest output voltage is reached when the inductor current reaches the load current (note the shaded area on the graph). If this voltage is higher than the lower limit ( $V_{\text{POS\_TRANS}}$ ), then the transient response passes.

Since the highest output voltage has the most severe requirements, any other modes are satisfied by a design optimized for the highest output voltage.

$$ESR_{\text{MAX}} := \frac{V_{\text{POS\_TRANS}}}{(I_{\text{MAX\_FL}} - I_{\text{LKGMAX}})}$$

$$ESR_{\text{MAX}} = 3.333 \times 10^{-3} \Omega$$

For the second condition, the inductor value is determined, which is a function of the highest desired switching frequency. The maximum frequency occurs at the highest input voltage. As a reasonable compromise between efficiency and component size, a maximum switching frequency of 350kHz is desired.

$$F_S := 350 \text{ K}\cdot\text{Hz}$$

$$d_{\text{MIN}} := \frac{V_{\text{MAX\_NL}}}{V_{\text{INMAX}}}$$

$$L_{\text{MIN}} := d_{\text{MIN}} \cdot \frac{(V_{\text{INMAX}} - V_{\text{MAX\_NL}})(ESR_{\text{MAX}} + R_{\text{CS}})}{F_S \cdot V_{\text{RIPPLE}} \cdot \left( \frac{ESR_{\text{MAX}} + R_{\text{CS}}}{ESR_{\text{MAX}}} \right)}$$

$$L_{\text{MIN}} = 5.422 \times 10^{-7} \text{ H}$$

The design is based on the following three factors: 1) minimum inductance requirement; 2) low DCR; 3) height and package size consideration. The design choice is made based upon the requirement of the converter design, including minimum inductance, minimum saturation current, efficiency, foot area, maximum allowable height, and device availability. In the current demo board design,

$$L_1 := 0.60 \cdot \mu\text{H}$$

This value of inductance is required up to maximum load. Inductors with a swinging choke characteristic, where the zero current value of inductance is much less than the full load current inductance can be used, as long as the above restriction is met. Then, the worst-case (low input voltage) response time (the time for the current to reach the new transient value) is:

$$dT := \frac{L_1 \cdot (I_{\text{MAX\_FL}} - I_{\text{LKGMAX}})}{V_{\text{INMIN}} - V_{\text{MAX\_NL}}}$$

$$dT = 1.326 \times 10^{-6} \text{ s}$$

Add 100ns for the typical propagation delay from a change at the output to the MOSFET switch turning on in reaction. Since the shaded area is, the total charge taken out of the capacitor is  $\Delta Q = C / dV = (dI/dt)/2$ . This is calculated using the following equation.

$$C_{\text{MINP}} := \frac{(I_{\text{MAX\_FL}} - I_{\text{LKGMAX}})(dT + 1 \cdot 10^{-7} \cdot \text{sec})}{V_{\text{POS\_TRANS}}}$$

$$C_{\text{MINP}} = 4.278 \times 10^{-4} \text{ F}$$

This condition applies only to the positive transient.

**POWER MANAGEMENT**

**Applications Information (Cont.)**

**LOAD RELEASE**

The worst-case for the transient load release is when the hysteresis has just reached the maximum, (i.e. the high-side switch has just turned of). At this time the inductor has reached its peak current as calculated below.

$$I_{RIPPLE} := \frac{(V_{INMAX} - V_{MAX\_F})}{L_1 \cdot F_S}$$

RIPPLE = 6.01 A

$I_{t0} := I_{MAX}$

$I_{t0} = 23.005 \text{ A}$

The load is stepping from high to low.

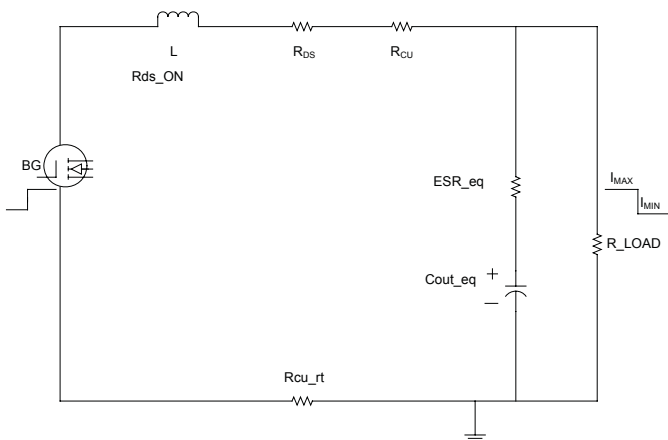

Immediately after the load steps down from  $I_{MAX}$  to  $I_{MIN}$ , the high side FET is turned off, and the bottom FET is turned on after the dead time. It is assumed for the worst-case condition that at  $t = 0$ , the inductor current is initially at its maximum;. After  $t = 0$ , the inductor discharges at a rate equal to  $V_{FL} / L$  (ignoring secondary order effects such as  $R_{ds\_on}$  drop, current sense resistor and copper losses). The energy released from the output inductor during load step-down, charges the output capacitors and is dissipated through the following means:  $R_{ds\_on}$ ,  $R_{cs}$ ,  $R_{cu}$ ,  $R_{cu\_rt}$ , ESR of the output capacitors and load.

$t := 0, 10 \text{ n.s.}.. 10 \mu\text{s}$

$$I_L(t) := \left( I_{t0} - \frac{V_{MAX\_FL} \cdot t}{L_1} \right)$$

$I_{CAP}(t) := I_L(t) - I_{LKGMAX}$

Since the output inductor is discharging at a fixed rate, there are two terms contributing to the increase of the voltage on the output capacitors: 1) is due to the ESR of the output capacitor; 2) is due to the added charge contributed by the inductor current.

$$V_{ESR}(t, N_{CAP}) := I_{CAP}(t) \cdot \frac{R_{ESR}}{N_{CAP}}$$

$$dV_{CAP}(t, N_{CAP}) := \frac{I_{CAP}(t) \cdot t}{C_{OUT} \cdot N_{CAP}}$$

$$V_{TOTAL}(t, N_{CAP}) := V_{ESR}(t, N_{CAP}) + dV_{CAP}(t, N_{CAP})$$

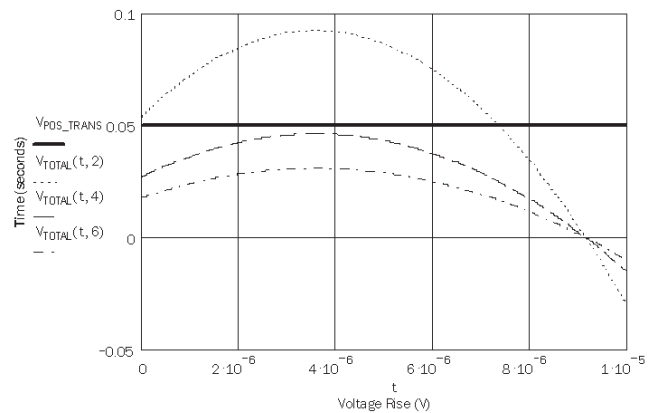

The chart above shows the system response for the capacitors defined in Step 1 and the chart to follow shows the details of the response for the chosen number of output capacitors.

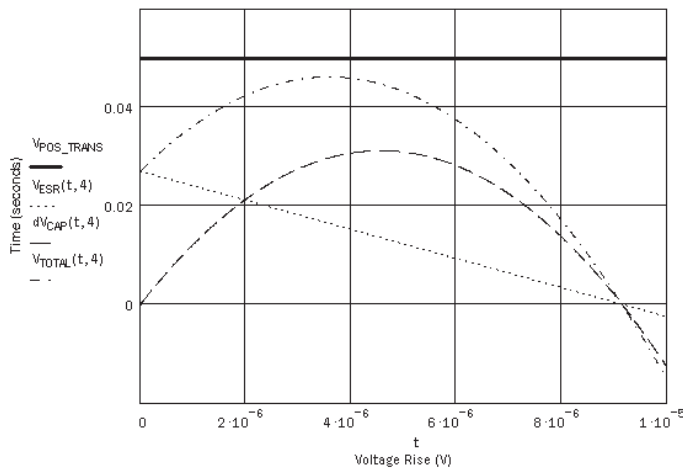
**POWER MANAGEMENT**
**Applications Information (Cont.)**

**Step 3 — Setting RHYS**

The next step is to calculate  $R_{HYS}$ . Since the SC453 is a hysteretic controller, it regulates the amount of output ripple according to a hysteresis value set by  $R_{HYS}$ . The designer must therefore decide upon the amount of desired output ripple, and then set  $R_{HYS}$  accordingly.

The hysteresis controls the amount of ripple voltage at the point of regulation, which is the point between the inductor and the current sense resistor. The amount of ripple at the output is defined by the current sense resistor and the output capacitor ESR. This factor is taken into account in the equation shown below relating  $V_{RIPPLE}$  to  $V_{HYS}$ .

To achieve tight accuracy, it is recommended that the output ripple be set to 20mV peak-to-peak.

$$ESR := \frac{R_{ESR}}{N_{CAP}} \quad ESR = 1.5 \times 10^{-3} \Omega$$

$$V_{RIPPLE} = 0.02 \text{ V}$$

$$V_{HYS} := V_{RIPPLE} \cdot \frac{(R_{CS} + ESR)}{ESR}$$

$$V_{HYS} = 0.033 \text{ V}$$

$V_{HYS}$  is created by switching a current source ( $I_{HYS}$ ) through a resistor in series with the CMP pin. The  $I_{HYS}$  value is controlled via  $R_{HYS}$ . For simplicity it is easier to select a value for CMP resistor ( $R_7$ , see Typical Application Circuit on page 2) and then calculate  $R_{HYS}$  as follows.

$$R_7 := 1K \cdot \Omega$$

$$R_{HYS} := \frac{2 \cdot V_{REF}}{\left( \frac{V_{HYS}}{R_7} \right)}$$

$$R_{HYS} = 102.0 \text{ K}\Omega$$

In the SC453 application circuit,  $R_{HYS}$  consists of three resistors ( $R_3$ ,  $R_4$  and  $R_5$ ) in parallel with  $R_{14}$ . These resistors also form the dividers for  $BOOTV$  and  $SLPV$ . Note also that depending on circuit layout and parasitics,  $R_{HYS}$  may have to be adjusted slightly to obtain optimum performance. (The above resistors will be calculated after the  $PBOOT$  and deeper sleep voltages are set later in this procedure). To increase hysteresis without having to change the divider resistors, a fourth resistor ( $R_{14}$ ), can be added. Additional hysteresis is needed when inductances in the current sense paths cause additional signal that adds to the resistive signal, limiting the accuracy of the calculations.

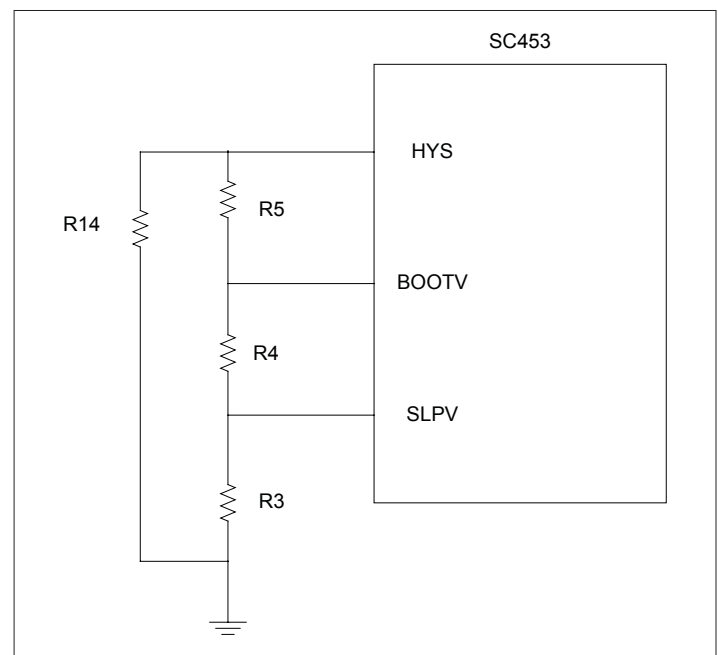

**POWER MANAGEMENT**
**Applications Information (Cont.)**
**Step 4 — BOOTV Design**

The boot-up voltage for  $V_{CORE}$  is set at 1.2V. For the SC453 typical application circuit, R3, R4, and R5 form a voltage divider off  $V_{REF}$  and are used to set the boot voltage. For simplicity  $R_{BOOT} := R3 + R4$ .

$$V_{BOOT} := 1.2 \text{ V}$$

$$R_{HYS} := \frac{1}{\frac{1}{R_{25}} + \frac{1}{R_{BOOT} + R_5}}$$

$$R_{BOOT} := \frac{V_{BOOT} \cdot R_5}{V_{REF} - V_{BOOT}}$$

**Step 5 — Sleep Voltage Design**

The sleep voltage is set at 0.750V nominally using the R3 - R4 - R5 divider.

$$V_{SLP} := 0.750 \text{ V}$$

$$R_3 := V_{SLP} \cdot \frac{(R_4 + R_5)}{V_{REF} - V_{SLP}}$$

R3, R4, and R5 are calculated using a matrix to solve the simultaneous equations. R14 is set at 1M $\Omega$  as a placeholder:

$$R_{14} := 1000 \text{ K}\Omega$$

$$M_x := \begin{pmatrix} 1 & 1 & 1 \\ 1 & 1 & -\frac{V_{BOOT}}{V_{REF} - V_{BOOT}} \\ 1 & V_{SLP} \cdot \frac{-1}{V_{REF} - V_{SLP}} & V_{SLP} \cdot \frac{-1}{V_{REF} - V_{SLP}} \end{pmatrix}$$

$$v := \begin{pmatrix} \frac{R_{14} \cdot R_{HYS}}{R_{14} - R_{HYS}} \\ 0 \\ 0 \end{pmatrix}$$

$$\text{soln} := \text{Isolve}(M_x, v) \quad \text{soln} = \begin{pmatrix} 5.011 \times 10^4 \\ 3.007 \times 10^4 \\ 3.341 \times 10^4 \end{pmatrix} \Omega$$

$$R_3 := (1 \ 0 \ 0) \cdot \text{soln} \quad R_3 = 5.011 \times 10^4 \Omega$$

$$R_4 := (0 \ 1 \ 0) \cdot \text{soln} \quad R_4 = 3.007 \times 10^4 \Omega$$

$$R_5 := (0 \ 0 \ 1) \cdot \text{soln} \quad R_5 = 3.341 \times 10^4 \Omega$$

From the standard 1% resistor value table, the following values are chosen according to the calculation results.

$$R_5 = 33.2\text{K}\Omega$$

$$R_4 = 30.1\text{K}\Omega$$

$$R_3 = 49.9\text{K}\Omega$$

**Step 6 — Current Limit Calculation**

Setting the threshold for current limit is a relatively straightforward process. To do this the peak current calculation is based on the maximum DC value plus the worst-case ripple current. The following calculations apply for a single phase. Worst-case ripple occurs at the highest input voltage. Since ripple is also inversely proportional to inductance, it is recommended that the minimum inductance value be used based on the manufacturer's specified tolerance:

$$L_{LOW} := L_1 \cdot (1 - 20\%) \quad L_{LOW} = 4.8 \times 10^{-7} \text{ H}$$

$$I_{RIPPLE\_MAX} := \frac{(V_{INMAX} - V_{MAX\_NL})d_{MIN}}{L_{LOW} \cdot F_S}$$

$$I_{RIPPLE\_MAX} = 6.777 \text{ A}$$

**POWER MANAGEMENT**
**Applications Information (Cont.)**

To calculate the maximum DC value of current the maximum DC current must be added to the maximum ripple value to obtain peak current:

$$I_{PEAK} := I_{MAX\_FL} + \frac{I_{RIPPLE\_MAX}}{2}$$

$$I_{PEAK} = 23.389 \text{ A}$$

It is recommended that the current limit be set at 120% of the peak value to allow for inductor current overshoot during load transients.

$$I_{CLIM} := 120 \% \cdot I_{PEAK}$$

$$I_{CLIM} = 28.066 \text{ A}$$

The Current Limit Comparator internal to the SC453 monitors the output current and turns the high side switch off when the current exceeds the upper current limit threshold,  $I_{CLMAX}$  and re-enables only if the load current drops below the lower current limit threshold,  $I_{CLMIN}$ . The current is sensed by monitoring the voltage drop across the current sense resistor  $R_{CS}$ .

Current limiting will cycle from  $I_{CLMAX}$  to  $I_{CLMIN}$  for 32 switching cycles to allow for short term transients, then the converter is latched off.  $I_{CLMAX}$  and  $I_{CLMIN}$  are set according to the following equations.

$$I_{CLMAX} := 3 \cdot V_{REF} \cdot \frac{R_{CL}}{R_{HYS} \cdot R_{CS}}$$

$$I_{CLMIN} := 2 \cdot V_{REF} \cdot \frac{R_{CL}}{R_{HYS} \cdot R_{CS}}$$

The current limit is set at  $I_{CLIM} = I_{CLMAX}$ , and then solve for  $R_{CL}$ , which is  $R_6$  in the typical applications circuit. For balance,  $R_8$ , in series with the CLRF pin is kept the same value as  $R_6$ .

$$R_{CL} := \frac{I_{CLIM} \cdot R_{HYS} \cdot R_{CS}}{2.5 \cdot V_{REF}}$$

$$R_{CL} = 673.59 \ \Omega \quad R_6 := 681 \ \Omega$$

$$R_8 := R_6 \quad R_8 = 681 \ \Omega$$

**Step 7 — Small Capacitors/Resistor Selection**

Several small capacitors are required for signal filtering. Refer to the Typical Application Circuit on page 2. Use SMT ceramic capacitors with an X7R or better temperature coefficient. COG is preferred.

$C_{11}$  and  $R_7$  are used to filter the hysteretic ripple signal. The components are sized to provide filtering above the 5th harmonic of the fundamental.

$$C_{11} := \frac{1}{2 \cdot \Pi \cdot R_7 \cdot F_S \cdot 5}$$

$$C_{11} = 9.095 \times 10^{-11} \text{ F}$$

In the evaluation board design a 100pF ceramic capacitor is used for  $C_{11}$ . The DAC output requires a 1nF capacitor ( $C_{23}$ ) for high frequency noise filtering. The values for  $C_{12}$  and  $C_{13}$  are calculated in a similar manner, though they are returned to the CORE pin because that is the reference point for the current limit comparator.

$$C_{12} := \frac{1}{2 \cdot \Pi \cdot R_6 \cdot F_S \cdot 5} \quad C_{13} := C_{12}$$

$$C_{12} = 1.335 \times 10^{-10} \text{ F} \quad C_{13} = 1.335 \times 10^{-10} \text{ F}$$

**POWER MANAGEMENT**
**Applications Information (Cont.)**
**Step 8 — Calculate Input RMS Current**

In order to calculate the worst-case RMS current for the input capacitors, the efficiency at  $V_{IN\_MIN}$  and full load, is conservatively set at 80%. The actual converter efficiency depends on component selection, layout, airflow, etc.

$$P_{OUT} := I_{MAX\_FL} \cdot V_{MAX\_FL} \quad P_{OUT} = 23.64 \text{ W}$$

$$P_{IN} := \frac{P_{OUT}}{85\%}$$

$$I_{IN\_DC} := \frac{P_{IN}}{V_{IN\_MIN}} \quad D := \frac{V_{MAX\_FL}}{V_{IN\_MIN}} \quad I_{IN\_DC} = 3.476 \text{ A}$$

$$I_{RMS} := \sqrt{\left[ (I_{MAX\_FL}) - I_{IN\_DC} \right]^2 \cdot D + \left[ I_{IN\_DC}^2 \cdot (1 - D) \right]}$$

$$I_{RMS} = 7.116 \text{ A}$$

$$C_{I\_RMS} := 2 \text{ A}$$

Using an RMS current rating of 2A, typical of 10 $\mu$ F, 25V MLCC capacitors, the number of required capacitors is calculated as shown below.

$$C_{I\_NUM} := \text{ceil} \left( \frac{I_{RMS}}{C_{I\_RMS}} \right) \quad C_{I\_NUM} = 4$$

The calculation indicates that four capacitors are needed to satisfy the worst-case RMS current requirement.

**Input Capacitance Calculation Using Ripple Voltage**

The allowable input ripple voltage seen at input capacitance is denoted  $dV_{in}$ . For this example 250mV is used as the maximum allowable input ripple voltage. The actual ripple voltage varies with duty cycle (D). The maximum value occurs at  $D = 0.5$ .

$$dV_{in} := 250 \text{ mV}$$

$$D_{MAX} := 0.5$$

$$T_{in} := \frac{1}{F_S}$$

$$C_{IN\_MIN} := \frac{I_{PEAK}}{2} \cdot \left( D_{MAX} - D_{MAX}^2 \right) \cdot \frac{T_{in}}{dV_{in}}$$

$$C_{IN\_MIN} = 3.341 \times 10^{-5} \text{ F}$$

$$C_{IN} := 10 \mu\text{F}$$

$$N_{IN\_MIN\_RIPPLE} := \text{ceil} \left( \frac{C_{IN\_MIN}}{C_{IN}} \right)$$

$$N_{IN\_MIN\_RIPPLE} = 4$$

Based on the above calculations, four capacitors are needed to satisfy the input ripple voltage requirement.

**Step 9 — OVP**

No calculations are necessary for Over-Voltage Protection. If  $V_{CORE}$  is greater than +14% of the DAC (i.e., out of the power good window), the SC453 will latch off and hold the low-side driver on permanently (for each phase). Either the power or EN must be recycled to clear the latch. The latch is disabled during soft-start and VID/Deeper Sleep transitions. The latch is enabled if  $V_{CORE}$  exceeds 2V even during VID/Deeper Sleep transitions to ensure that the processor maximum is not exceeded. The table on Page 13 is a summary of fault conditions using SC453.

**Step 10 — Soft-Start/DAC Slew Control**

The soft-start cap C21 in the SC453 design serves three conditions.

- 1) Define the start-up ramp.
- 2) Define the DAC slew rate during sleep and VID transitions. During VID transitions the SS current is nominally +/- 120 $\mu$ A; during sleep transitions the SS current increases to +/- 240 $\mu$ A;
- 3) During start-up, the SS current is normally +/- 6.5 $\mu$ A.

**POWER MANAGEMENT**
**Applications Information (Cont.)**

Three soft-start examples are based on the previous three conditions for SC453 application.

**1. Start-Up**

$$I_{SS} := 6.5 \mu\text{A}$$

$$dt_{SU} := 3 \text{ m s}$$

$$dV_{dacSU} := V_{MAX\_NL}$$

$$C_{SS\_max\_startup} := \frac{I_{SS} \cdot dt_{SU}}{dV_{dacSU}}$$

$$C_{SS\_max\_startup} = 1.609 \times 10^{-8} \text{ F}$$

**2. VID Change:**

$$I_{SSV} := 120 \mu\text{A}$$

$$dt_V := 100 \mu\text{s}$$

$$dV_{dacV} := V_{MAX\_NL} - V_{MIN\_NL}$$

$$C_{SS\_max\_VID} := \frac{I_{SSV} \cdot dt_V}{dV_{dacV}}$$

$$C_{SS\_max\_VID} = 4.687 \times 10^{-8} \text{ F}$$

**3. Sleep Entry/Exit:**

$$I_{SSS} := 240 \mu\text{A}$$

$$dt_S := 33 \mu\text{s}$$

$$dV_{dacS} := V_{MAX\_NL} - V_{SLP}$$

$$C_{SS\_max\_drs} := \frac{I_{SSS} \cdot dt_S}{dV_{dacS}}$$

$$C_{SS\_max\_drs} = 1.714 \times 10^{-8} \text{ F}$$

Example 1 predicts the maximum capacitance allowed. In order to allow tolerance C22 = 15nF is chosen.

POWER MANAGEMENT

Outline Drawing - TSSOP-28

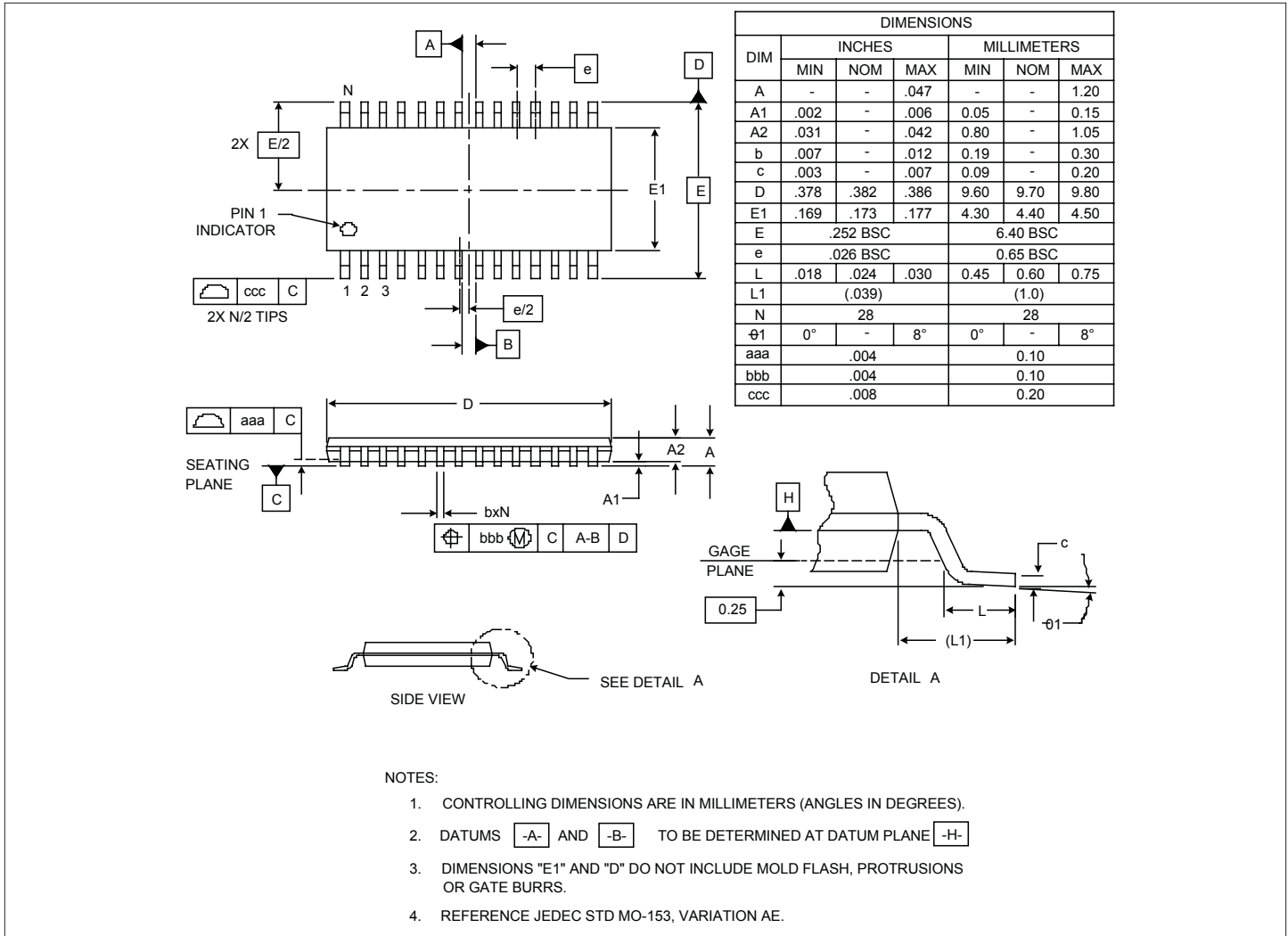

Marking Information TSSOP-28

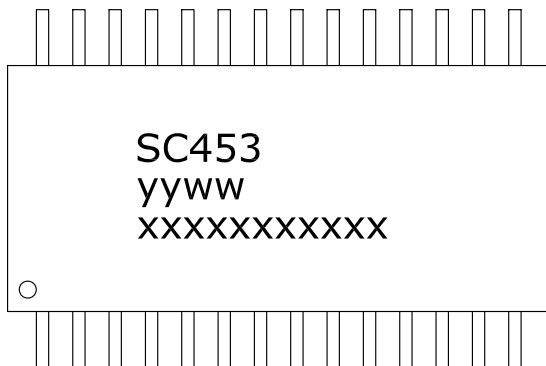

yyww = Date code  
 xxxxxxxxxxxx = Semtech lot number



POWER MANAGEMENT

Land Pattern - TSSOP-28

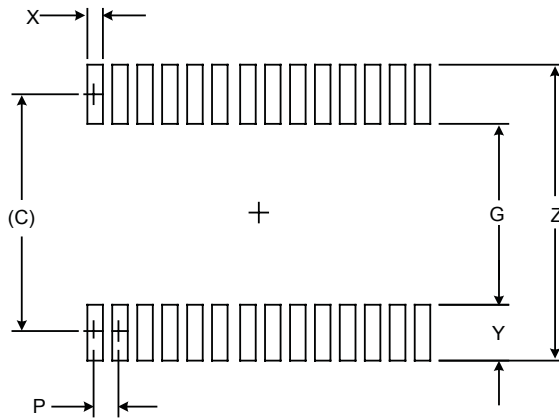

DIMENSIONS		
DIM	INCHES	MILLIMETERS
C	(.222)	(5.65)
G	.161	4.10
P	.026	0.65
X	.016	0.40
Y	.061	1.55
Z	.283	7.20

NOTES:

1. THIS LAND PATTERN IS FOR REFERENCE PURPOSES ONLY. CONSULT YOUR MANUFACTURING GROUP TO ENSURE YOUR COMPANY'S MANUFACTURING GUIDELINES ARE MET.

POWER MANAGEMENT

Outline Drawing - MLPQ-32

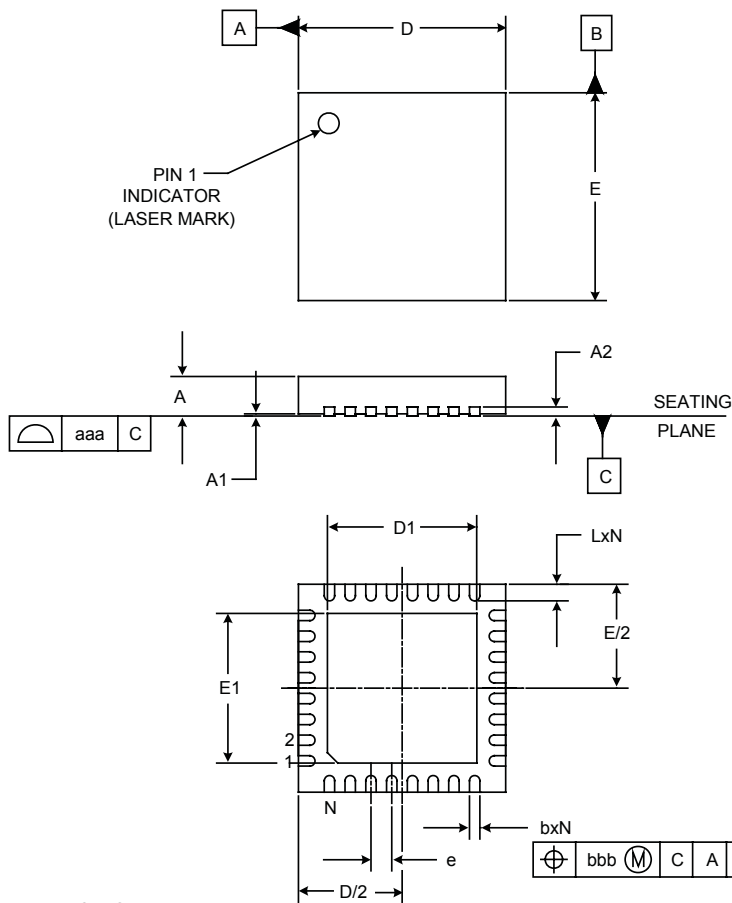

DIM	INCHES			MILLIMETERS		
	MIN	NOM	MAX	MIN	NOM	MAX
A	.031	-	.039	0.80	-	1.00
A1	.000	-	.002	0.00	-	0.05
A2	-	(.008)	-	-	(0.20)	-
b	.007	.010	.012	0.18	0.25	0.30
D	.193	.197	.201	4.90	5.00	5.10
D1	.140	.146	.150	3.30	3.70	3.80
E	.193	.197	.201	4.90	5.00	5.10
E1	.140	.146	.150	3.30	3.70	3.80
e	.020 BSC			0.50 BSC		
L	.012	.016	.020	0.30	0.40	0.50
N	32			32		
aaa	.003			0.08		
bbb	.004			0.10		

NOTES:

1. CONTROLLING DIMENSIONS ARE IN MILLIMETERS (ANGLES IN DEGREES).
2. COPLANARITY APPLIES TO THE EXPOSED PAD AS WELL AS THE TERMINALS.

Marking Information MLPQ-32

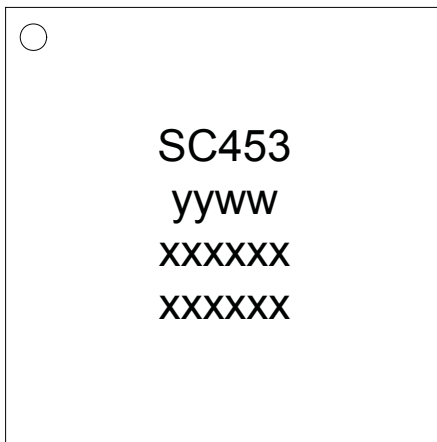

yyww = Date code  
 xxxxxx = Semtech lot number  
 xxxxxx = Semtech lot number