



Chipsmall Limited consists of a professional team with an average of over 10 year of expertise in the distribution of electronic components. Based in Hongkong, we have already established firm and mutual-benefit business relationships with customers from,Europe,America and south Asia,supplying obsolete and hard-to-find components to meet their specific needs.

With the principle of “Quality Parts,Customers Priority,Honest Operation,and Considerate Service”,our business mainly focus on the distribution of electronic components. Line cards we deal with include Microchip,ALPS,ROHM,Xilinx,Pulse,ON,Everlight and Freescale. Main products comprise IC,Modules,Potentiometer,IC Socket,Relay,Connector.Our parts cover such applications as commercial,industrial, and automotives areas.

We are looking forward to setting up business relationship with you and hope to provide you with the best service and solution. Let us make a better world for our industry!



## Contact us

Tel: +86-755-8981 8866 Fax: +86-755-8427 6832

Email & Skype: info@chipsmall.com Web: www.chipsmall.com

Address: A1208, Overseas Decoration Building, #122 Zhenhua RD., Futian, Shenzhen, China



### POWER MANAGEMENT

#### Description

The SC4614 is a high-speed, voltage mode PWM controller that provides the control and protection features necessary for a synchronous buck converter.

The SC4614 is designed to directly drive the top and bottom MOSFETs of the buck converter. It allows the converter to operate at 500kHz switching frequency with 4V to 25V power rail and as low as 0.5V output. It uses an internal 8.2V supply as the gate drive voltage for minimum driver power loss and MOSFET switching loss.

The SC4614 features soft-start, supply power under voltage lockout, and hiccup mode over current protection. The SC4614 monitors the output current by using the  $R_{ds(on)}$  of the bottom MOSFET in the buck converter that eliminates the need for a current sensing resistor. The SC4614 is offered in a MSOP-10 package.

#### Features

- ◆ 500kHz switching frequency
- ◆ 4V to 25V power rails
- ◆ 0.5V voltage reference for programmable output voltages
- ◆ Internal LDO for optimum gate drive voltage
- ◆ 1.5A gate drive current
- ◆ Adaptive non-overlapping gate drives provide shoot-through protection for MOSFETs
- ◆ Internal soft start
- ◆ Hiccup mode short circuit protection
- ◆ Power rail under voltage lockout
- ◆ MSOP-10 package, fully RoHS and WEEE compliant

#### Applications

- ◆ Embedded, low cost, high efficiency converters
- ◆ Point of load power supplies
- ◆ Set top box power supplies
- ◆ PDP/TFT TVs
- ◆ Consumer electronics

#### Typical Application Circuit

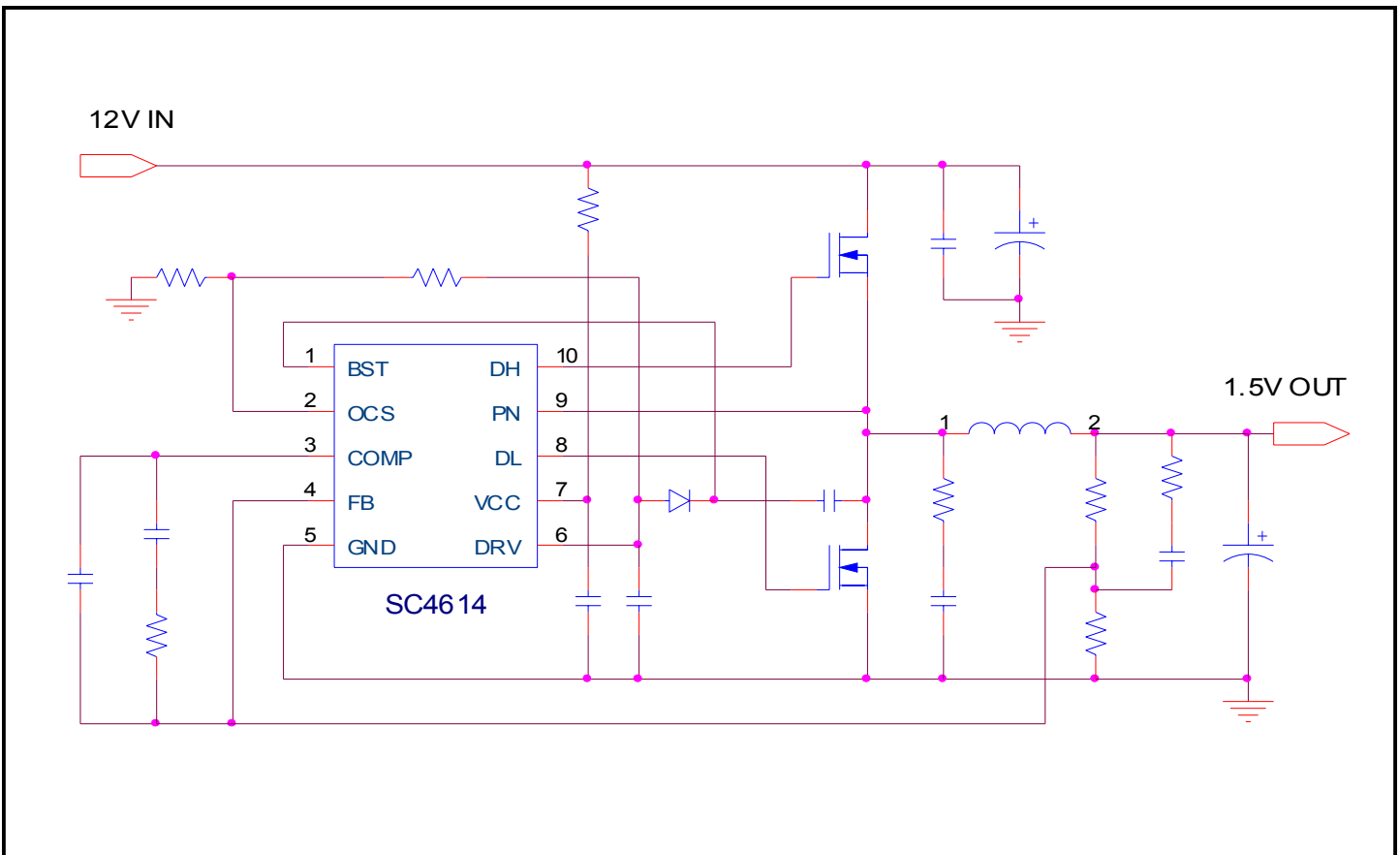

**POWER MANAGEMENT**
**Absolute Maximum Ratings**

Exceeding the specifications below may result in permanent damage to the device, or device malfunction. Operation outside of the parameters specified in the Electrical Characteristics section is not implied.

Parameter	Symbol	Maximum	Units
Input Supply Voltage	$V_{CC}$	20	V
BST to GND	$V_{BST}$	40	V
BST to PN	$V_{BST\_PN}$	10	V
PN to GND	$V_{PN}$	-1 to 30	V
PN to GND Negative Pulse ( $t_{pulse} < 20ns$ )	$V_{PN\_PULSE}$	-5	V
DL to GND	$V_{DL}$	-1 to +10	V
DL to GND Negative Pulse ( $t_{pulse} < 20ns$ )	$V_{DL\_PULSE}$	-3	V
DH to PN	$V_{DH\_PN}$	-1 to +10	V
DH to PN Negative Pulse ( $t_{pulse} < 20ns$ )	$V_{DH\_PULSE}$	-3	V
DRV to GND	$V_{DRV}$	10	V
Operating Ambient Temperature Range	$T_A$	-40 to 85	°C
Operating Junction Temperature	$T_J$	-40 to 125	°C
Thermal Resistance Junction to Ambient	$\theta_{JA}$	136	°C/W
Thermal Resistance Junction to Case	$\theta_{JC}$	45	°C/W
Lead Temperature (Soldering) 10s	$T_{LEAD}$	300	°C
Storage Temperature	$T_{STG}$	-65 to 150	°C

**Electrical Characteristics**

Unless specified:  $V_{CC} = 5V$  to  $18V$ ;  $V_{FB} = V_O$ ;  $V_{BST} - V_{PN} = 5V$  to  $8.2V$ ;  $T_A = -40$  to  $85^\circ C$

Parameter	Symbol	Conditions	Min	Typ	Max	Units
<b>General</b>						
VCC Supply Voltage	$V_{CC}$		4		18	V
VCC Quiescent Current	$I_{QVCC}$	$V_{CC} = 12V, V_{BST} - V_{PN} = 8.2V$		5	7	mA
VCC Under Voltage Lockout	$UV_{VCC}$	$V_{HYST} = 100mV$			4	V
BST to PN Supply Voltage	$V_{BST\_PN}$		4		10	V
BST Quiescent Current	$I_{QBST}$	$V_{CC} = 12V, V_{BST} - V_{PN} = 8.2V$			3	mA
<b>Internal LDO</b>						
LDO Output	$V_{DRV}$	$8.6V < V_{CC} < 18V$		8.2		V
Dropout Voltage	$V_{DROP}$	$4V < V_{CC} < 8.6V$		0.4		V



**POWER MANAGEMENT**
**Electrical Characteristics**

 Unless specified:  $V_{CC} = 5V$  to  $18V$ ;  $V_{FB} = V_O$ ;  $V_{BST} - V_{PN} = 5V$  to  $8.2V$ ;  $T_A = -40$  to  $85^\circ C$ 

Parameter	Symbol	Conditions	Min	Typ	Max	Units
<b>Switching Regulator</b>						
Reference Voltage	$V_{REF}$	$T_A = 25^\circ C, V_{CC} = 12V$	0.495	0.500	0.505	V
Load Regulation		$I_O = 0.2$ to $4A$		0.4		%
Line Regulation		$V_{CC} = 10V$ to $14V$		0.4		%
Operating Frequency	$F_S$		400	500	600	kHz
Ramp Amplitude <sup>(2)</sup>	$V_m$			0.8		V
Maximum Duty Cycle <sup>(2)</sup>	$D_{MAX}$			97		%
Minimum On-Time <sup>(2)</sup>	$T_{ON\_MIN}$			125		ns
DH Rising/Falling Time	$t_{SRC\_DH}$	6V Swing at $C_L = 3.3nF$ $V_{BST} - V_{PN} = 8.2V$		41		ns
	$t_{SINK\_DH}$			27		
DL Rising/Falling Time	$t_{SRC\_DL}$	6V Swing at $C_L = 3.3nF$ $V_{DRV} = 8.2V$		29		ns
	$t_{SINK\_DL}$			42		
DH, DL Nonoverlapping Time				30		ns
Soft Start Time		$T_A = 25^\circ C, V_{CC} = 12V$		1.5		ms
<b>Voltage Error Amplifier</b>						
Input Offset Voltage <sup>(2)</sup>				2		mV
Input Offset Current <sup>(2)</sup>				40		nA
Open Loop Gain <sup>(2)</sup>				80		dB
Unity Gain Bandwidth <sup>(2)</sup>				10		MHz
Output Source Current				0.9		mA
Output Sink Current				0.9		mA
Slew Rate <sup>(2)</sup>		For $C_L = 500pF$ Load		1.2		V/us

**Notes:**

- (1) This device is ESD sensitive. Use of standard ESD handling precautions is required.  
 (2) Guaranteed by design, not tested in production.

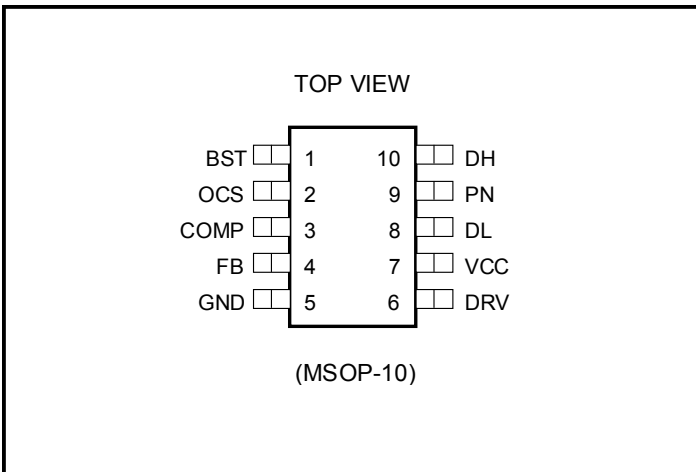
**POWER MANAGEMENT**
**Pin Configuration**

**Ordering Information**

Part Numbers	Package
SC4614MSTRT <sup>(1)(2)</sup>	MSOP-10
SC4614EVB	

**Note:**

(1) Only available in tape and reel packaging. A reel contains 2500 devices.

(2) Lead free product. This product is fully WEEE and RoHS compliant.

**Pin Descriptions**

Pin #	Pin Name	Pin Function
1	BST	Boost input for top gate drive bias.
2	OCS	Current limit setting. Connect resistors from this pin to DRV pin and to ground to program the trip point of load current. Refer to Applications Information Section for details.
3	COMP	Error amplifier output for compensation.
4	FB	Voltage feed back of synchronous buck converter.
5	GND	Chip ground.
6	DRV	Internal LDO output. Connect a 1uF ceramic capacitor from this pin to ground for decoupling. This voltage is used for chip bias, including gate drivers.
7	VCC	Chip input power supply.
8	DL	Gate drive for bottom MOSFET.
9	PN	Phase node. Connect this pin to bottom N-MOSFET drain.
10	DH	Gate drive for top MOSFET.

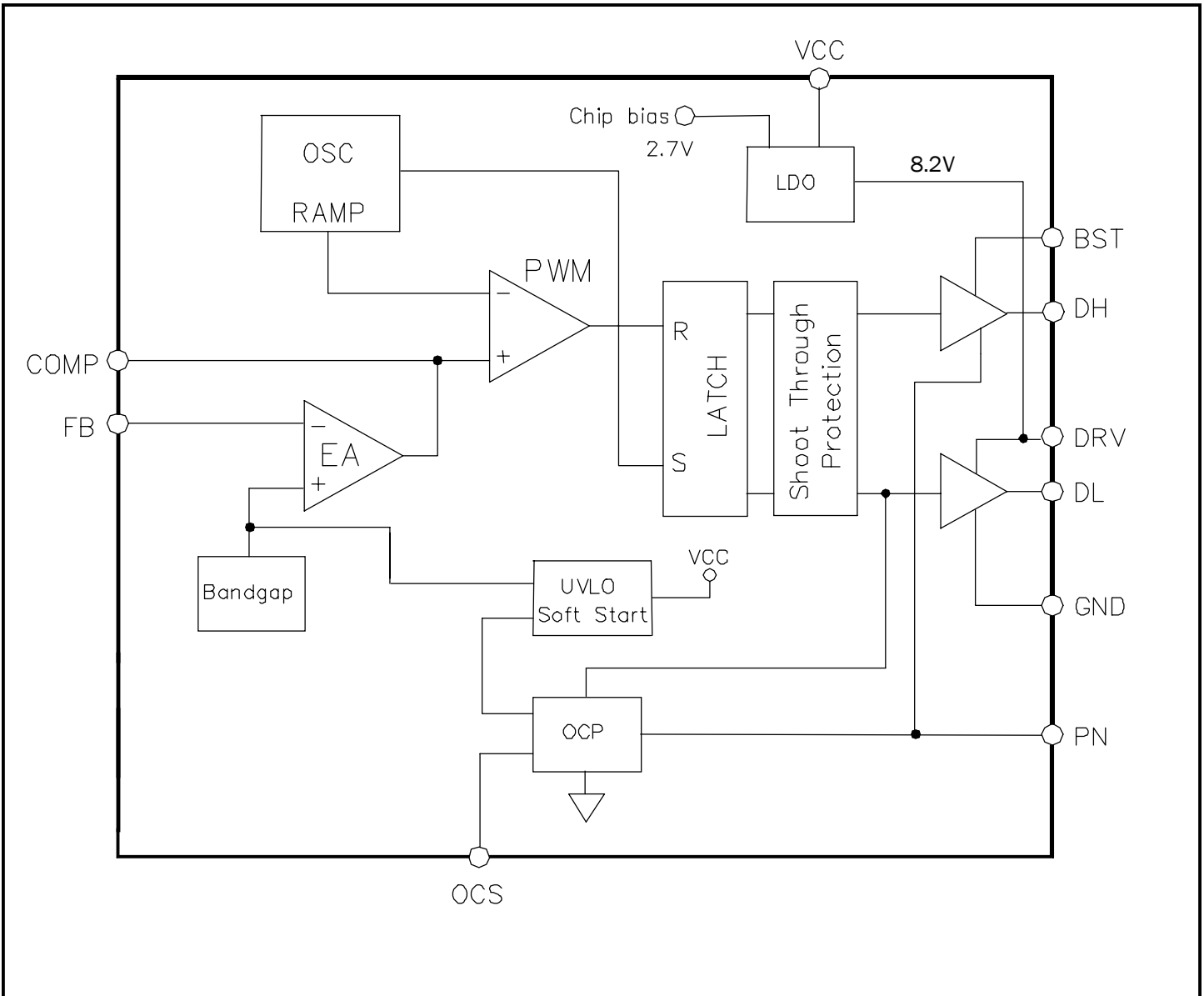

**THEORY OF OPERATION**

The SC4614 is a high-speed, voltage mode PWM controller that provides the control and protection features necessary for a synchronous buck converter.

As shown in the block diagram of the SC4614, the voltage-mode PWM controller consists of an error amplifier, a 500kHz ramp generator, a PWM comparator, a RS latch circuit, and two MOSFET drivers. The buck converter output voltage is fed back to the error amplifier negative input and is regulated to a reference voltage level. The error amplifier output is compared with the ramp to generate a PWM wave, which is amplified and used to drive the MOSFETs in the buck converter. The PWM wave at the phase node with the amplitude of  $V_{in}$  is filtered out to get a DC output. The PWM controller works with soft-start and fault monitoring circuitry to meet application requirements.

**UVLO, Start Up and Shut Down**

To initiate the SC4614, a supply voltage is applied to the Vcc pin. The top gate (DH) and bottom gate (DL) are held low until Vcc voltage exceeds UVLO (Under Voltage Lock Out) threshold, typically 4.0V. Then the internal Soft-Start (SS) capacitor begins to charge, the top gate remains low, and the bottom gate is pulled high to turn on the bottom MOSFET. When the SS voltage at the capacitor reaches 0.4V, the top and bottom gates of PWM controller begin to switch. The switching regulator output is slowly ramping up for a soft turn-on.

If the supply voltages at the Vcc pin falls below UVLO threshold during a normal operation, the SS capacitor begins to discharge. When the SS voltage reaches 0.4V, the PWM controller controls the switching regulator output to ramp down slowly for a soft turn-off.

**Hiccup Mode Short Circuit Protection**

The SC4614 uses low-side MOSFET  $R_{ds(on)}$  sensing for over current protection. In every switching cycle, after the bottom MOSFET is on for 150ns, the SC4614 detects the phase node voltage and compares it with an internal setting voltage. If the phase node is lower than the setting voltage, an overcurrent condition occurs. The SC4614 will discharge the internal SS capacitor and shut-down both outputs. After waiting for around 10 milliseconds, the SC4614 begins to charge the SS capacitor again and initiates a fresh startup. The startup and shut-down cycle will repeat until the short circuit is removed. This is called a hiccup mode short circuit protection.

To program a load trip point for short circuit protection, it is recommended to connect a 3.3k resistor from the OCS pin to the ground, and a resistor  $R_{set}$  from the OCS pin to the DRV pin, as shown in Fig. 1.

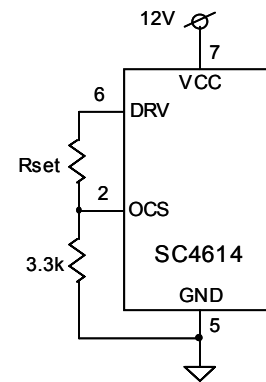

Fig. 1. Programming load trip point

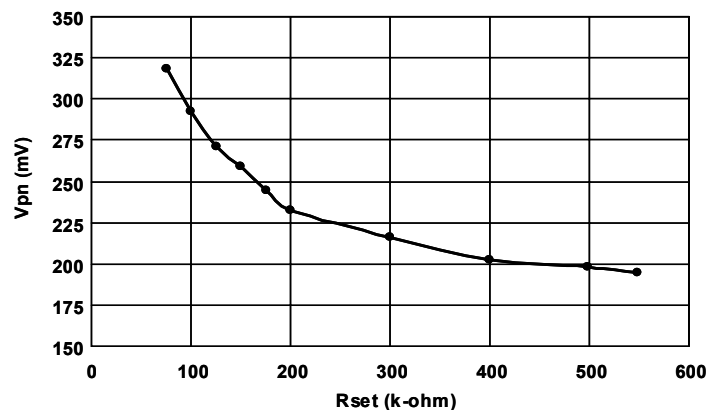

Fig. 2. Pull up resistor ( $R_{set}$ ) vs. trip voltage  $V_{pn}$

The resistor  $R_{set}$  can be found in Fig. 2 for a given phase node voltage  $V_{pn}$  at the load trip point. This voltage is the product of the inductor peak current at the load trip point and the  $R_{ds(on)}$  of the low-side MOSFET:

$$V_{pn} = I_{peak} \times R_{ds\_on}$$

The soft start time of the SC4614 is fixed at around 1.5ms. Therefore, the maximum soft start current is de-

**Applications Information (Cont.)**

terminated by the output inductance and output capacitance. The values of output inductor and output bulk capacitors have to be properly selected so that the soft start peak current does not exceed the load trip point of the short circuit protection.

**Internal LDO for Gate Drive**

An internal LDO is designed in the SC4614 to lower the 12V supply voltage for gate drive. A 1uF external ceramic capacitor connected in between DRV pin to the ground is needed to support the LDO. The LDO output is connected to the low gate drive internally, and has to be connected to the high gate drive through an external bootstrap circuit. The LDO output voltage is set at 8.2V. The manufacture data and bench tested results show that, for low  $R_{dson}$  MOSFETs run at applied load current, the optimum gate drive voltage is around 8.2V, where the total power losses of power MOSFETs are minimized.

**COMPONENT SELECTION**

General design guideline of switching power supplies can be applied to the component selection for the SC4614.

**Inductor and MOSFETs**

The selection of inductor and MOSFETs should meet thermal requirements because they are power loss dominant components. Pick an inductor with as high inductance as possible without adding extra cost and size. The higher inductance, the lower ripple current, the smaller core loss and the higher efficiency will be. However, too high inductance slows down output transient response. It is recommended to choose the inductance that creates an inductor ripple current of approximate 20% of maximum load current. So choose inductor value from:

$$L = \frac{5}{I_O \cdot f_{osc}} \cdot V_O \cdot \left(1 - \frac{V_O}{V_{IN}}\right)$$

The MOSFETs are selected by their  $R_{dson}$ , gate charge, and package specifications. The SC4614 provides 1.5A gate drive current and gives 50nC/1.5A=33ns switching time for driving a 50nC gate charge MOSFET. The switching time  $t_s$  contributes to the top MOSFET switching loss:

$$P_S = I_O \cdot V_{IN} \cdot t_s \cdot f_{OSC}$$

There is no significant switching loss for the bottom MOSFET because of its zero voltage switching. The con-

duction losses of the top and bottom MOSFETs are given by:

$$P_{C\_TOP} = I_O^2 \cdot R_{dson} \cdot D$$

$$P_{C\_BOT} = I_O^2 \cdot R_{dson} \cdot (1 - D)$$

If the requirement of total power losses for each MOSFET is given, the above equations can be used to calculate the values of  $R_{dson}$  and gate charge, then the devices can be determined accordingly. The solution should ensure the MOSFET is within its maximum junction temperature at highest ambient temperature.

**Output Capacitor**

The output capacitors should be selected to meet both output ripple and transient response criteria. The output capacitor ESR causes output ripple  $V_{RIPPLE}$  during the inductor ripple current flowing in. To meet output ripple criteria, the ESR value should be:

$$R_{ESR} < \frac{L \cdot f_{OSC} \cdot V_{RIPPLE}}{V_O \cdot \left(1 - \frac{V_O}{V_{IN}}\right)}$$

The output capacitor ESR also causes output voltage transient  $V_T$  during a transient load current  $I_T$  flowing in. To meet output transient criteria, the ESR value should be:

$$R_{ESR} < \frac{V_T}{I_T}$$

To meet both criteria, the smaller one of above two ESRs is required.

The output capacitor value also contributes to load transient response. Based on a worst case where the inductor energy 100% dumps to the output capacitor during the load transient, the capacitance then can be calculated by:

$$C > L \cdot \frac{I_T^2}{V_T^2}$$

**Input Capacitor**

The input capacitor should be chosen to handle the RMS ripple current of a synchronous buck converter. This value



is given by:

$$I_{RMS} = \sqrt{(1-D) \cdot I_{IN}^2 + D \cdot (I_o - I_{IN})^2}$$

where  $I_o$  is the load current,  $I_{IN}$  is the input average current, and  $D$  is the duty cycle. Choosing low ESR input capacitors will help maximize ripple rating for a given size.

### Bootstrap Circuit

The SC4614 uses an external bootstrap circuit to provide a voltage at the BST pin for the top MOSFET drive. This voltage, referring to the Phase Node, is held up by a bootstrap capacitor. Typically, it is recommended to use a 1uF ceramic capacitor with 16V rating and a commonly available diode IN4148 for the bootstrap circuit.

### Filters for Supply Power

For each pin of DRV and Vcc, it is recommended to use a 1uF/16V ceramic capacitor for decoupling. In addition, place a small resistor (10 ohm) in between the Vcc pin and the supply power for noise reduction.

## CONTROL LOOP DESIGN

The goal of compensation is to shape the frequency response characteristics of the buck converter to achieve a better DC accuracy and a faster transient response for the output voltage, while maintaining the loop stability.

The block diagram in Fig. 3 represents the control loop of a buck converter designed with the SC4614. The control loop consists of a compensator, a PWM modulator, and a LC filter.

The LC filter and PWM modulator represent the small signal model of the buck converter operating at fixed switching frequency. The transfer function of the model is given by:

$$\frac{V_o}{V_c} = \frac{V_{IN}}{V_m} \cdot \frac{1 + sR_{ESR}C}{1 + sL/R + s^2LC}$$

where  $V_{IN}$  is the power rail voltage,  $V_m$  is the amplitude of the 500kHz ramp, and  $R$  is the equivalent load.

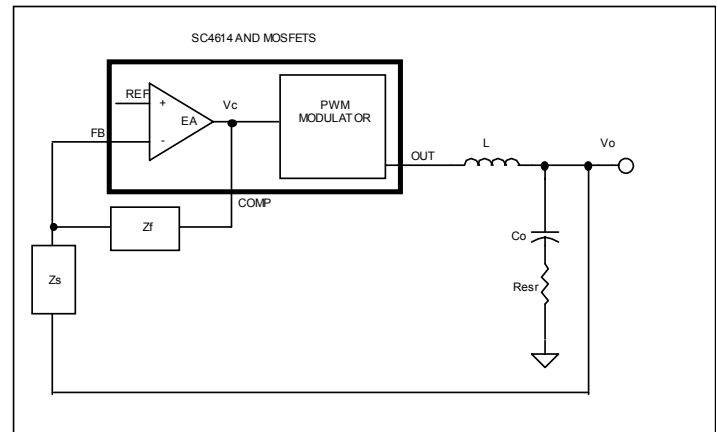

Fig. 3. Block diagram of the control loop

The model is a second order system with a finite DC gain, a complex pole pair at  $F_o$ , and an ESR zero at  $F_z$ , as shown in Fig. 4. The locations of the poles and zero are determined by:

$$F_o = \frac{1}{\sqrt{LC}}$$

$$F_z = \frac{1}{R_{ESR}C}$$

The compensator in Fig. 3 includes an error amplifier and impedance networks  $Z_f$  and  $Z_s$ . It is implemented by the circuit in Fig. 5. The compensator provides an integrator, double poles and double zeros. As shown in Fig. 4, the integrator is used to boost the gain at low frequency. Two zeros are introduced to compensate excessive phase lag at the loop gain crossover due to the integrator (-90deg) and complex pole pair (-180deg). Two high frequency poles are designed to compensate the ESR zero and attenuate high frequency noise.

Applications Information (Cont.)

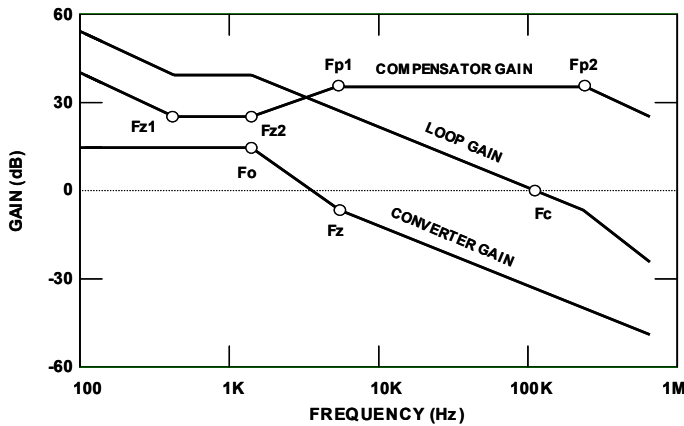

Fig. 4. Bode plots for control loop design

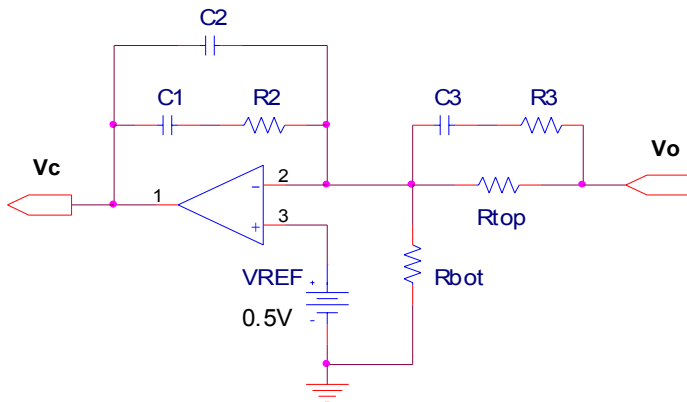

Fig. 5. Compensation network

The top resistor  $R_{top}$  of the voltage divider in Fig. 5 can be chosen from 1k to 5k. Then the bottom resistor  $R_{bot}$  is found from:

$$R_{bot} = \frac{0.5V}{V_o - 0.5V} \cdot R_{top}$$

where 0.5V is the internal reference voltage of the SC4614.

The other components of the compensator can be calculated using following design procedure:

(1). Plot the converter gain, including LC filter and PWM modulator.

(2). Select the open loop crossover frequency  $F_c$  located at 10% to 20% of the switching frequency. At  $F_c$ , find the required DC gain.

(3). Use the first compensator pole  $F_{p1}$  to cancel the ESR zero  $F_z$ .

(4). Have the second compensator pole  $F_{p2}$  at half the switching frequency to attenuate the switching ripple and high frequency noise.

(5). Place the first compensator zero  $F_{z1}$  at or below 50% of the power stage resonant frequency  $F_o$ .

(6). Place the second compensator zero  $F_{z2}$  at or below the power stage resonant frequency  $F_o$ .

A MathCAD program is available upon request for the calculation of the compensation parameters.

LAYOUT GUIDELINES

The switching regulator is a high di/dt power circuit. Its Printed Circuit Board (PCB) layout is critical. A good layout can achieve an optimum circuit performance while minimizing the component stress, resulting in better system reliability. During PCB layout, the SC4614 controller, MOSFETs, inductor, and power decoupling capacitors have to be considered as a unit.

The following guidelines are typically recommended for using the SC4614 controller.

(1). Place a 4.7uF to 10uF ceramic capacitor close to the drain of top MOSFET for the high frequency and high current decoupling. The loop formed by the capacitor, the top and bottom MOSFETs must be as small as possible. Keep the input bulk capacitors close to the drain of the top MOSFETs.

(2). Place the SC4614 over a quiet ground plane to avoid pulsing current noise. Keep the ground return of the gate drive short.

(3). Connect bypass capacitors as close as possible to the decoupling pins (DRV and Vcc) to the ground pin GND. The trace length of the decoupling capacitor on DRV pin should be no more than 0.2" (5mm).

(4). Locate the components of the bootstrap circuit close to the SC4614.

POWER MANAGEMENT

Applications Information (Cont.)

Typical Application Schematics with 12V Input

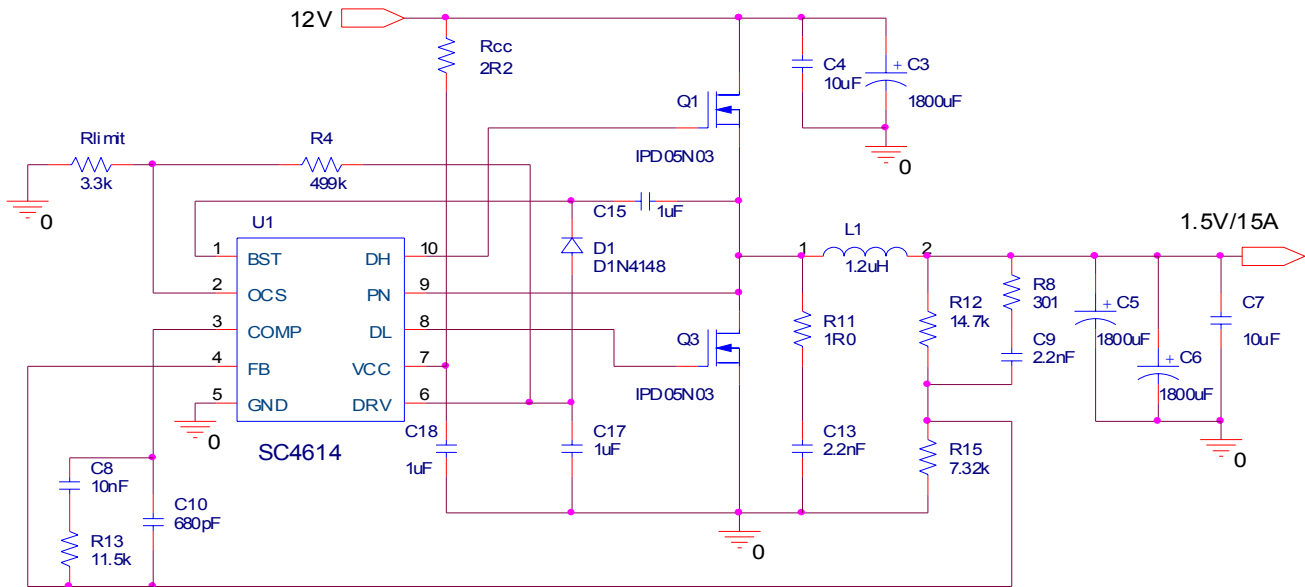

Bill of Materials (12V Input)

Item	Quantity	Reference	Part	Vendor
1	1	C4	10uF/16V	Vishay
2	1	C7	10uF/6.3V	Vishay
3	1	C3	1800uF/16V	Rubycon, MBZ
4	2	C5,C6	1800uF/6.3V	Rubycon, MBZ
5	3	C15,C17,C18	1uF	Vishay
6	1	C9	2.2nF	Vishay
7	1	C13	2.2nF	Vishay
8	1	C8	10nF	Vishay
9	1	C10	680pF	Vishay
10	1	D1	D1N4148	Any
11	1	L1	1.2uH	Cooper Electr. Tech
12	2	Q3,Q1	IPD05N03	Infineon
13	1	Rcc	2R2	Vishay
14	1	Rlimit	3.3k	Vishay
15	1	R4	499k	Vishay
16	1	R8	301	Vishay
17	1	R11	1R0	Vishay
18	1	R12	14.7k	Vishay
19	1	R15	7.32k	Vishay
20	1	R13	11.5k	Vishay
21	1	U1	SC4614	SEMTECH

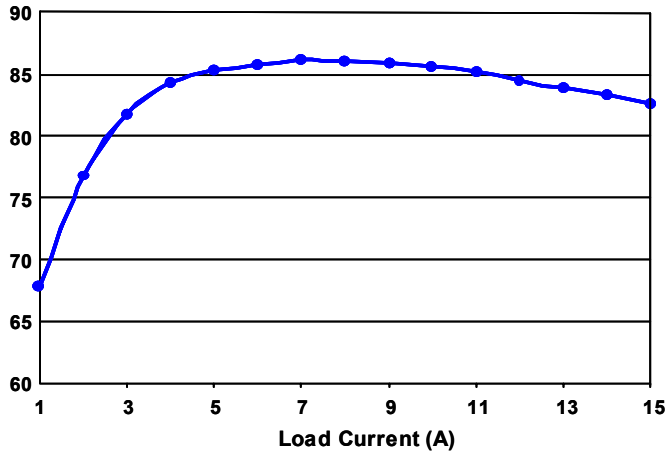
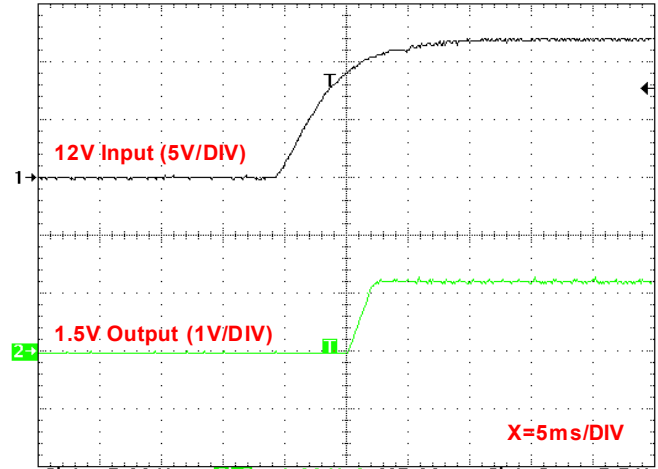
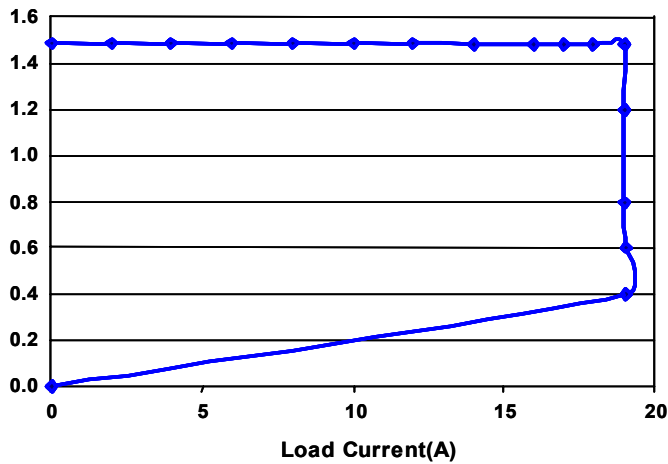
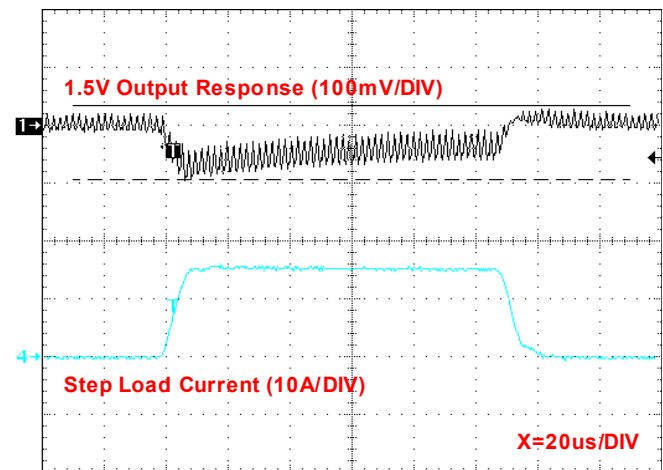
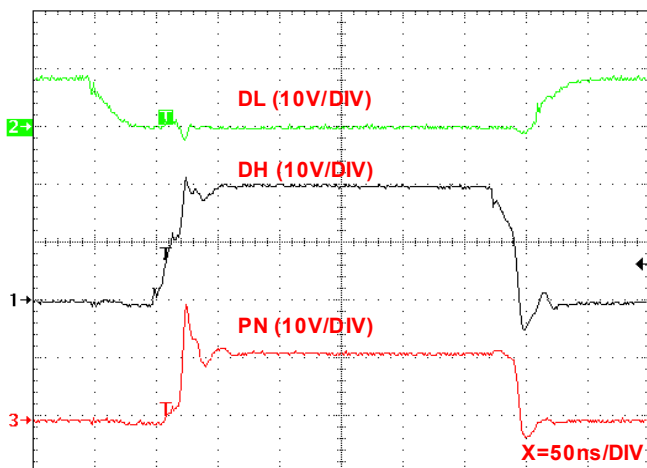
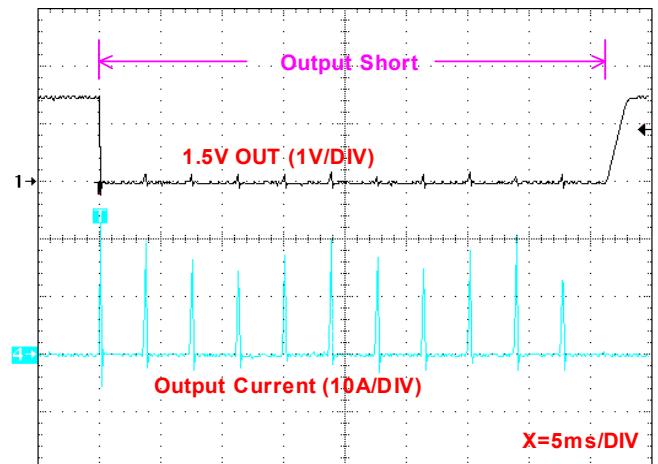
**Performance Characteristics (12V Input)**
**Efficiency (%) vs Load Current**

**Start up**

**Load Characteristics (Output vs Load Current)**

**Transient Response**

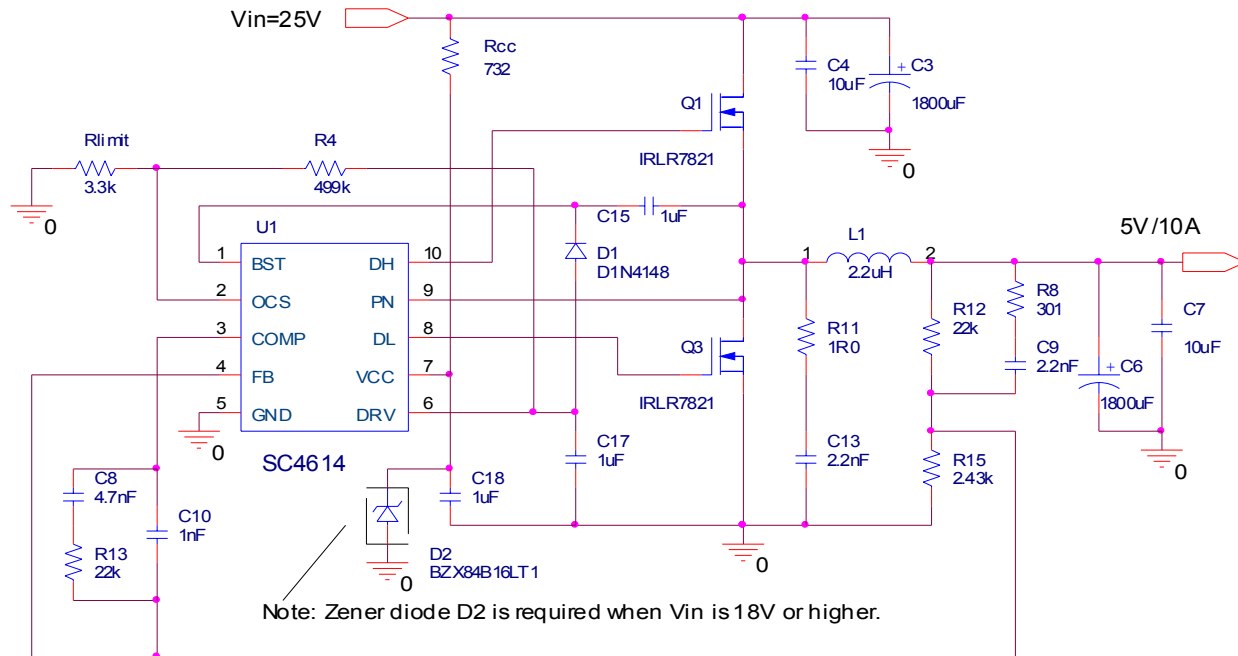
**Gate Waveforms (Io=15A)**

**Short Circuit Protection**

POWER MANAGEMENT

Applications Information (Cont.)

Typical Application Schematics with 25V Input



Bill of Materials (25V Input)

Item	Quantity	Reference	Part	Vendor
1	1	C4	10uF/35V	Murata
2	1	C7	10uF/6.3V	Vishay
3	1	C3	1800uF/35V	Rubycon
4	1	C6	1500uF/6.3V	Rubycon, MBZ
5	3	C15,C17,C18	1uF	Vishay
6	1	C9	2.2nF	Vishay
7	1	C13	2.2nF	Vishay
8	1	C8	4.7nF	Vishay
9	1	C10	1nF	Vishay
10	1	D1	D1N4148	Any
11	1	D2	BZX84B16LT1	ON Semi
12	1	L1	2.2uH	Cooper Electr. Tech
13	2	Q3,Q1	IRLR7821	IR
14	1	Rcc	732	Vishay
15	1	Rlimit	3.3k	Vishay
16	1	R4	499k	Vishay
17	1	R8	301	Vishay
18	1	R11	1R0	Vishay
19	1	R12	22k	Vishay
20	1	R15	2.43k	Vishay
21	1	R13	22k	Vishay
22	1	U1	SC4614	SEMTECH

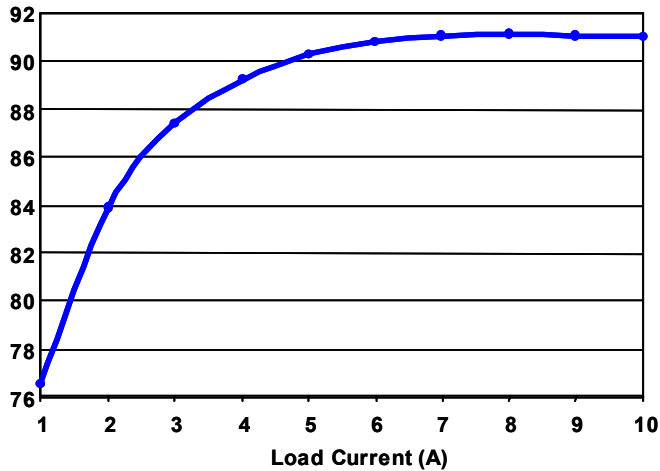
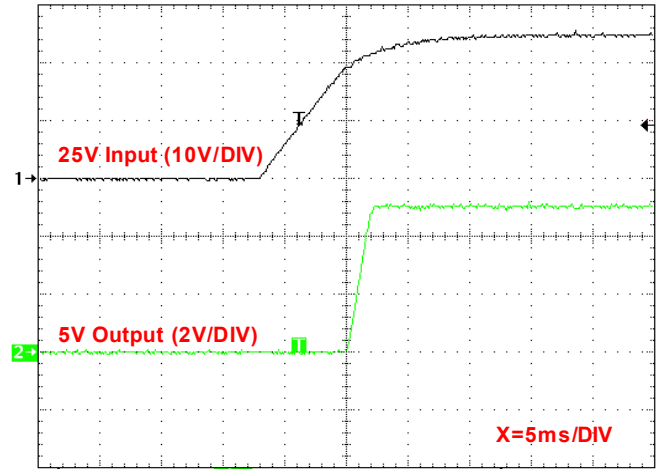
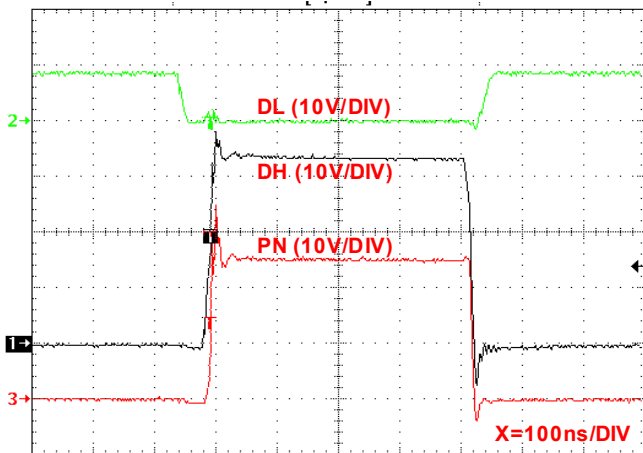
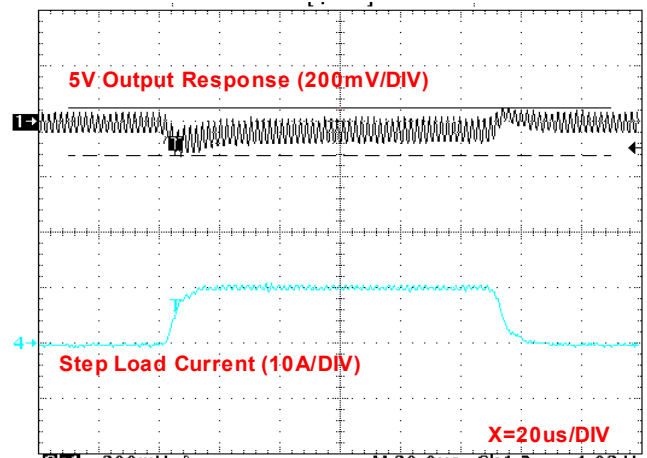

**Performance Characteristics (25V Input)**
**Efficiency (%) vs Load Current**

**Start up**

**Gate Waveforms (Io=10A)**

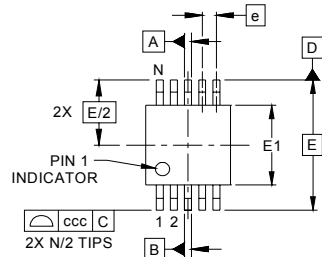
**Transient Response**

POWER MANAGEMENT

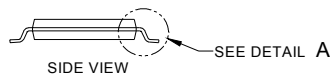
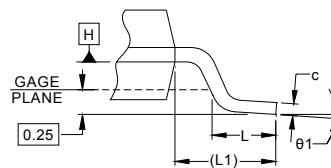
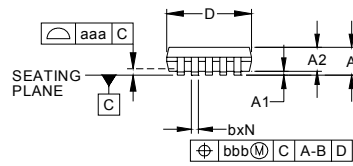
Outline Drawing - MSOP-10



DIM	INCHES			MILLIMETERS		
	MIN	NOM	MAX	MIN	NOM	MAX
A	-	-	.043	-	-	1.10
A1	.000	-	.006	0.00	-	0.15
A2	.030	-	.037	0.75	-	0.95
b	.007	-	.011	0.17	-	0.27
c	.003	-	.009	0.08	-	0.23
D	.114	.118	.122	2.90	3.00	3.10
E1	.114	.118	.122	2.90	3.00	3.10
E	.193 BSC			4.90 BSC		
e	.020 BSC			0.50 BSC		
L	.016	.024	.032	0.40	0.60	0.80
L1	(.037)			(.95)		
N	10			10		
θ1	0°	-	8°	0°	-	8°
aaa	.004			0.10		
bbb	.003			0.08		
ccc	.010			0.25		



NOTES:

1. CONTROLLING DIMENSIONS ARE IN MILLIMETERS (ANGLES IN DEGREES).
2. DATUMS [-A-] AND [-B-] TO BE DETERMINED AT DATUM PLANE [-H-].
3. DIMENSIONS "E1" AND "D" DO NOT INCLUDE MOLD FLASH, PROTRUSIONS OR GATE BURRS.
4. REFERENCE JEDEC STD MO-187, VARIATION BA.

Land Pattern - MSOP-10

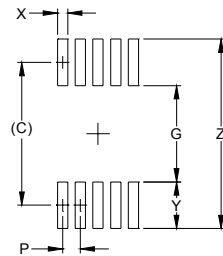

DIM	DIMENSIONS	
	INCHES	MILLIMETERS
C	(.161)	(4.10)
G	.098	2.50
P	.020	0.50
X	.011	0.30
Y	.063	1.60
Z	.224	5.70

NOTES:

1. THIS LAND PATTERN IS FOR REFERENCE PURPOSES ONLY. CONSULT YOUR MANUFACTURING GROUP TO ENSURE YOUR COMPANY'S MANUFACTURING GUIDELINES ARE MET.

Contact Information

Semtech Corporation  
 Power Management Products Division  
 200 Flynn Road, Camarillo, CA 93012  
 Phone: (805)498-2111 FAX (805)498-3804