



Chipsmall Limited consists of a professional team with an average of over 10 year of expertise in the distribution of electronic components. Based in Hongkong, we have already established firm and mutual-benefit business relationships with customers from,Europe,America and south Asia,supplying obsolete and hard-to-find components to meet their specific needs.

With the principle of "Quality Parts,Customers Priority,Honest Operation,and Considerate Service",our business mainly focus on the distribution of electronic components. Line cards we deal with include Microchip,ALPS,ROHM,Xilinx,Pulse,ON,Everlight and Freescale. Main products comprise IC,Modules,Potentiometer,IC Socket,Relay,Connector.Our parts cover such applications as commercial,industrial, and automotives areas.

We are looking forward to setting up business relationship with you and hope to provide you with the best service and solution. Let us make a better world for our industry!



## Contact us

Tel: +86-755-8981 8866 Fax: +86-755-8427 6832

Email & Skype: info@chipsmall.com Web: www.chipsmall.com

Address: A1208, Overseas Decoration Building, #122 Zhenhua RD., Futian, Shenzhen, China



### POWER MANAGEMENT

#### Features

- $V_{IN}$  Range — 4.5V to 27V,  $V_{OUT}$  Range — Up to 50V
- Step-up (Boost) Controller
  - Ultra-Fast Transient Response
  - Integrated Soft-start
  - Programmable Switching Frequency
- Linear Current Sinks
  - 8 Strings, up to 50mA/String
  - Current Matching  $\pm 1\%$
  - Current Accuracy  $\pm 2\%$
- PWM Dimming
  - String-by-String Phase Shifting
  - Input Dimming Frequency 100Hz-30kHz
  - User Selectable 9 or 10 Bits Dimming Resolution
  - Optional Synchronization to VSYNC/HSYNC Signal
- Optional External p-MOSFET Disconnect Switch
  - True Load Disconnect and Inrush Current Limiting
- I<sup>2</sup>C Interface
  - Fault Status — Open/Short LED, UVLO, OTP
  - Device Control — SYNC Freq, PLL Setting
- Protection Features
  - Open/Shorted LED(s) and adjustable OVP
  - Over-Temperature and UVLO Shutdown Protection
- 4 X 4 X 0.6 (mm) 28-pin QFN Package

#### Applications

- Notebook PCs, UMPC, LCD Monitors, and Tablet PCs

#### Typical Application Circuit

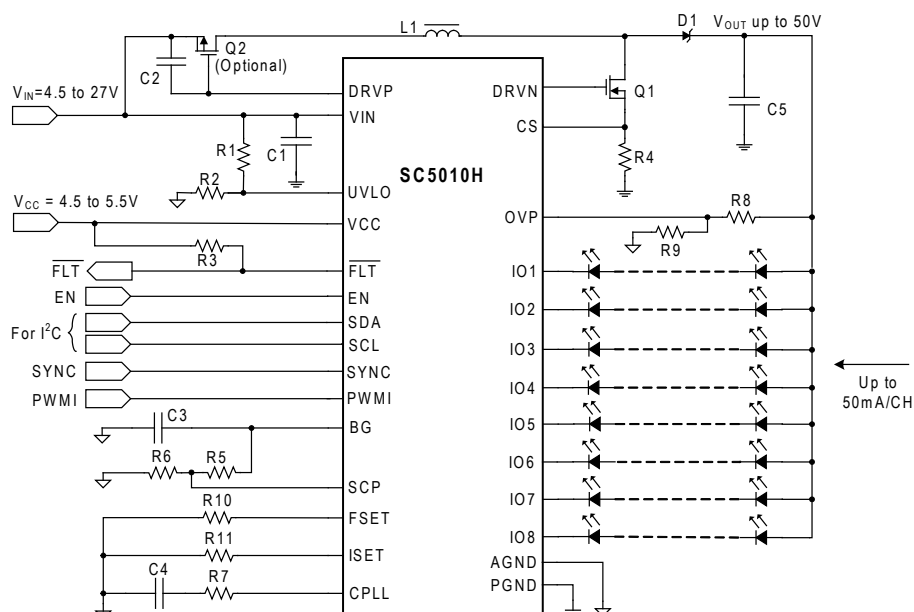

#### Description

The SC5010H is an 8-channel high-precision, high-efficiency step-up (Boost) LED driver for backlight applications. It features wide input voltage range (4.5V to 27V), flexible output configuration, wide analog and PWM dimming range, phase shifting and fading. It also features video signal synchronization (VSYNC), I<sup>2</sup>C interface, and numerous protection features. An optional disconnect p-MOSFET provides true load disconnection and inrush current limiting.

The boost controller, with programmable switching frequency from 200kHz to 2.2MHz, maximizes efficiency by dynamically minimizing the output voltage while maintaining LED string current accuracy. It provides excellent line and load response with no external compensation components. Each linear current sink is matched within  $\pm 1\%$  for superb lighting uniformity, and the accuracy of each string current is  $\pm 2\%$ . An external resistor adjusts the current from 10-50mA per string. It also features PWM dimming resolution of 9 or 10 bits (user selectable) over dimming frequency from 100Hz to 20kHz, synchronized to the SYNC signal or the boost oscillator. String-by-string phase shifting reduces the demand on the input/output capacitance, decreases EMI, and improves dimming linearity.

SC5010H is available in a low-profile, thermally enhanced, 4 X 4 X 0.6(mm) QFN 28-pin package.