



Chipsmall Limited consists of a professional team with an average of over 10 year of expertise in the distribution of electronic components. Based in Hongkong, we have already established firm and mutual-benefit business relationships with customers from,Europe,America and south Asia,supplying obsolete and hard-to-find components to meet their specific needs.

With the principle of “Quality Parts,Customers Priority,Honest Operation,and Considerate Service”,our business mainly focus on the distribution of electronic components. Line cards we deal with include Microchip,ALPS,ROHM,Xilinx,Pulse,ON,Everlight and Freescale. Main products comprise IC,Modules,Potentiometer,IC Socket,Relay,Connector.Our parts cover such applications as commercial,industrial, and automotives areas.

We are looking forward to setting up business relationship with you and hope to provide you with the best service and solution. Let us make a better world for our industry!



Contact us

Tel: +86-755-8981 8866 Fax: +86-755-8427 6832

Email & Skype: info@chipsmall.com Web: www.chipsmall.com

Address: A1208, Overseas Decoration Building, #122 Zhenhua RD., Futian, Shenzhen, China



POWER MANAGEMENT

Description

The SC805 is a fully integrated, single cell, constant-current (CC)/constant-voltage (CV) Lithium-Ion battery charger in a tiny 3x3 mm thermally enhanced lead free MLP package. The SC805 can operate as a stand-alone charger or in conjunction with a Power Management Controller (PMIC).

The SC805 has a pre-charge function for trickle charging deeply discharged batteries. The fast charge current is enabled automatically when the battery voltage reaches the required threshold. When the battery reaches the constant voltage or CV portion of the charge curve the SC805 switches to CV regulation mode. In this mode the output current decays as the battery charges until the termination current is reached and the SC805 signals the charge cycle is complete. The SC805 can be configured to continue charging for a predetermined time before turning off, or to turn off immediately upon termination. After turning off its output, The SC805 enters monitor mode. If the battery voltage drops by 100mV from the CV voltage a new charge cycle will begin. The timer function also protects against charging faulty batteries by turning off if the pre-charge time exceeds 1/4 of the total programmed charge duration.

The SC805 also provides battery detection, and a battery NTC thermistor interface to disable charging when the battery temperature exceeds safe-to-charge limits.

The SC805 can also function as a general purpose current source or as a current source for charging nickel-cadmium (NiCd) and nickel-metal-hydride (NiMH) batteries.

Typical Application Circuit

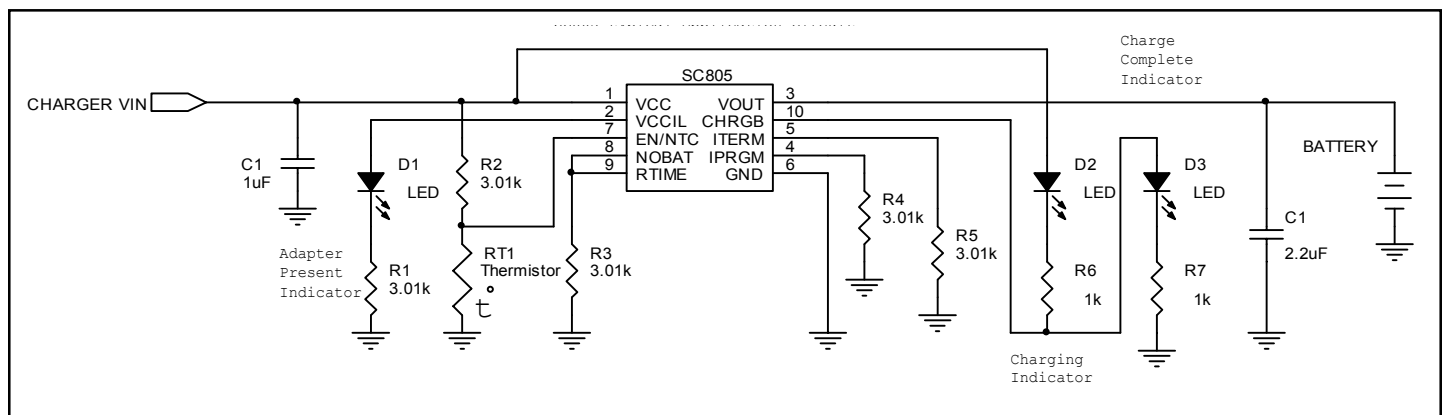

Features

- ◆ Fully integrated charger with FET pass transistor, reverse-blocking diode, sense resistor and thermal protection
- ◆ High Accuracy Charge Current*
- ◆ Tiny 3mm x 3mm 10 lead MLP package
- ◆ Programmable precharge, fastcharge & termination current
- ◆ Battery voltage controlled to 1% accuracy
- ◆ Built in timer for protection and complete charging
- ◆ NTC interface with battery detection
- ◆ Soft-start for step load and adaptor plug-in
- ◆ Up to 1A continuous charge current
- ◆ Input voltage range from 3V to 6V allows seamless charging from current limited adapter
- ◆ Provides adapter voltage VCCIL to power external accessories
- ◆ Battery Present detection and output indicator
- ◆ Operates in charger or LDO-mode without battery
- ◆ 0.1µA battery drain current in shutdown and monitor modes
- ◆ Over current protection in all charging modes
- ◆ CHRGB output communicates charging and end of charge cycle

*Patent Pending

Applications

- ◆ Cellular phones
- ◆ PDA's
- ◆ Handheld meters
- ◆ Charging stations
- ◆ USB chargers
- ◆ Digital cameras
- ◆ Programmable current source

POWER MANAGEMENT
Absolute Maximum Ratings

Exceeding the specifications below may result in permanent damage to the device or device malfunction. Operation outside of the parameters specified in the Electrical Characteristics section is not implied.

Parameter	Symbol	Maximum	Units
VCC, VCCIL, EN/NTC to GND		-0.3 to 7.0	V
VOOUT, NOBAT, IPRGM, CHRGB, ITERM, RTIME to GND		-0.3 to +6.0	V
Power Dissipation MLP (Derate 20mW/ °C above 85°C)	Pd	2	W
Thermal Impedance, Junction to Case	θ_{JA}	50*	°C/W
Junction Temperature	T_J	150	°C
Operating Ambient Temperature Range	T_A	-40 to +85	°C
Peak IR Reflow temperature, soldering 20s-40s	T_{LEAD}	260	°C
Storage Temperature Range	T_{STG}	-65 to 150	°C
VOOUT short to GND		Continuous	A
$I_{VCCIL} + I_{VOOUT}$ Total Output Current	I_{OUT_TOT}	1	A

*Calculated from package in still air, mounted to 3" to 4.5", 4 layer FR4 PCB with thermal vias under the exposed pad per JESD51 standards.

Electrical Characteristics

Unless otherwise noted: VCC = 4.75V - 5.25V

Parameter	Symbol	Conditions	25°C			T_A (-40°C to +85°C)		Units
			Min	Typ	Max	Min	Max	
Input Voltage				5		3.15	5.9	V
Operating Current	ICC_{DIS}	Shutdown Mode, EN = 0		0.1			1	µA
	ICC_{CHG}	Charging Mode CHRGB, ITERM, IPRG = 0µA		1.2			2.25	mA
Battery Leakage Current	I_{leak_BAT}	VCC = 0V		0.1			1	µA
Regulated Voltage	VBAT***			4.20		4.16	4.24	V
Battery Pre-Charge Current	IPREQ	ITERM Resistor R = 3.01k		50		44	54	mA
Battery Termination Current	ITERMQ			50		44.5	53.5	
Battery Fast-Charge Current	I_{FastQ_1} I_{FastQ_2}	IPRGM = 15k IPRGM = 1.87k VBATTERY = 3.8V Dropout Voltage = 550mV		100 787		91.5 -5	111.5 +5	mA %
Battery Fast-Charge Max Current Limit		2.8V < VBATTERY < VBAT					1.0	A
Iprog Regulated Voltage	V_{IPRGM}			1.5		1.4	1.6	V
Iterm Regulated Voltage	V_{ITERM}			1.5		1.4	1.6	V

POWER MANAGEMENT
Electrical Characteristics (Cont.)

Parameter	Symbol	Conditions	25°C			T _A (-40°C to +85°C)		Units
			Min	Typ	Max	Min	Max	
Vin OVP Rising Threshold	V _{T_OVPR}			6.8		6.4	7.5	V
Vin OVP Falling Threshold	V _{T_OVPF}			6.4	6.0	5.9	7.15	V
Vin OVP Hysteresis	V _{T_OVPH}			375		150		mV
Vin UVLO Rising Threshold	V _{T_UVLOR}			2.8		2.55	3.15	V
Vin UVLO Falling Threshold	V _{T_UVLOF}			2.75		2.5	3.1	V
Vin UVLO Hysteresis	V _{T_UVLOH}			50		30		mV
Vbat Precharge Threshold	V _{T_PREQR}			2.8		2.7	2.9	V
Vbat Recharge Threshold	V _{T_REQ}	VBAT - VBATTERY		100		60	140	mV
Pre-Charge Fault Time-Out	T _{PQFAULT}	Rtime=39.2k		38		30.7	44.7	min
Charge Complete Time-Out	T _{FASTQ}	Rtime=39.2k		2.5		2.0	3.0	hrs
Timer Disable Threshold	V _{T_TIMER}	Rtime VIL Voltage		1.0		0.7		V
LDO-Mode Select Threshold	V _{T_INTTS}	VCC-RTIME Voltage		1.1		0.7		V
En-NTC Thresholds	V _{T_DIS}	SC805 disable		< 1.1		0.7		V
	V _{T_NTCH}	NTC Hot Vth Vcc=5		0.3V _{CC}		0.294V _{CC}	0.314V _{CC}	V
	V _{T_NTCC}	NTC Cold Vth Vcc=5		0.75V _{CC}		0.736V _{CC}	0.756V _{CC}	V
	V _{T_NOBAT}	No Battery Detect Vcc=5		0.95V _{CC}		0.93V _{CC}	0.97V _{CC}	V
	NTC _{HYS}	Hot/Cold Hysteresis		50				mV
Over Temperature Shutdown	OT	Hysteresis = 10°C		150				°C
CHRGB LED Output	V _{CB_VO}	Charge Complete Isrc=2mA		4.5		4.3	5.0	V
	V _{CB_V}	Charging Isnk=2mA		0.2		0.05	0.5	V
	I _{CB_OFF}	Disable or LDO-mode off leakage		0.1			1.0	µA
NoBat Output	V _{NB_VO}	EN=VCC, Isrc=1mA		4.8		4.5		V
	I _{NB_OFF}	EN=VCC/2 off leakage		0.1			1.0	µA
VCCIL Resistance	VCCIL _R	R VCC to VCCIL, I=100mA		0.2				W
Reduced Fastcharge Current	I _{fqRed}	Vout=3.8v, Rprog=1.87k VCCIL load = 200mA		585		545	625	mA

* Tied to PCB with 1 Square Inch, 2 Ounce Copper. T_{ja}=41°C/W using JESD 51 Standard

** Charge current is reduced by VCCIL current. VCCIL current is not limited by the IC

*** Vbat load=75mA. See typical performance curves for load regulation.

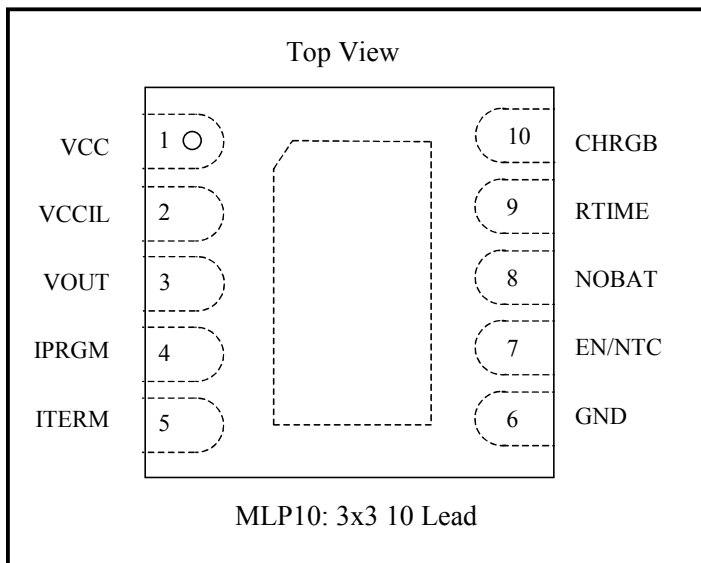
POWER MANAGEMENT
Pin Configuration

Ordering Information

Device ⁽¹⁾	Package
SC805IMLTRT ⁽²⁾	MLP-10
SC805EVB	Evaluation Board

Note:

(1) Only available in tape and reel packaging. A reel contains 3,000 devices.

(2) Available in lead-free packaging only. This product is fully WEEE and RoHS compliant.

Pin Descriptions

Pin #	Pin Name	Pin Function
1	VCC	Supply pin, connect to adaptor power.
2	VCCIL	Adapter input voltage. This pin provides a bias voltage approximately equal to the adapter input voltage. The output current when charging will be reduced by the load current on VCCIL.
3	VOUT	Charger output, connect to battery.
4	IPRGM	Current limit program pin for charge and LDO-mode. Requires a resistor to ground to program fast-charge current.
5	ITERM	Selection for current termination and pre-charge current. Requires a resistor to ground to program pre-charge and termination current.
6	GND	Ground
7	EN/NTC	Combined device enable/disable and NTC input pin. Logic low disables the device. Analog voltages between 0.3VCC and 0.75VCC enable the NTC function. Voltages above 95% of VCC force the NOBAT output high.
8	NOBAT	Battery Present Indicator. This output goes high when the NTC voltage exceeds 95% of VCC indicating the Battery and NTC have been removed.
9	RTIME	Charge time programming resistor. Connect a resistor between RTIME and GND to program the charge time. Force the pin to GND to disable the timer. Force the pin to VCC to select LDO-mode.
10	CHRGB	Output status indicator designed to drive two LEDs. Connect cathode of the 'charging' led to this pin to indicate charge in progress. Connect the anode of the 'charge complete' led to this pin to indicate charge complete.

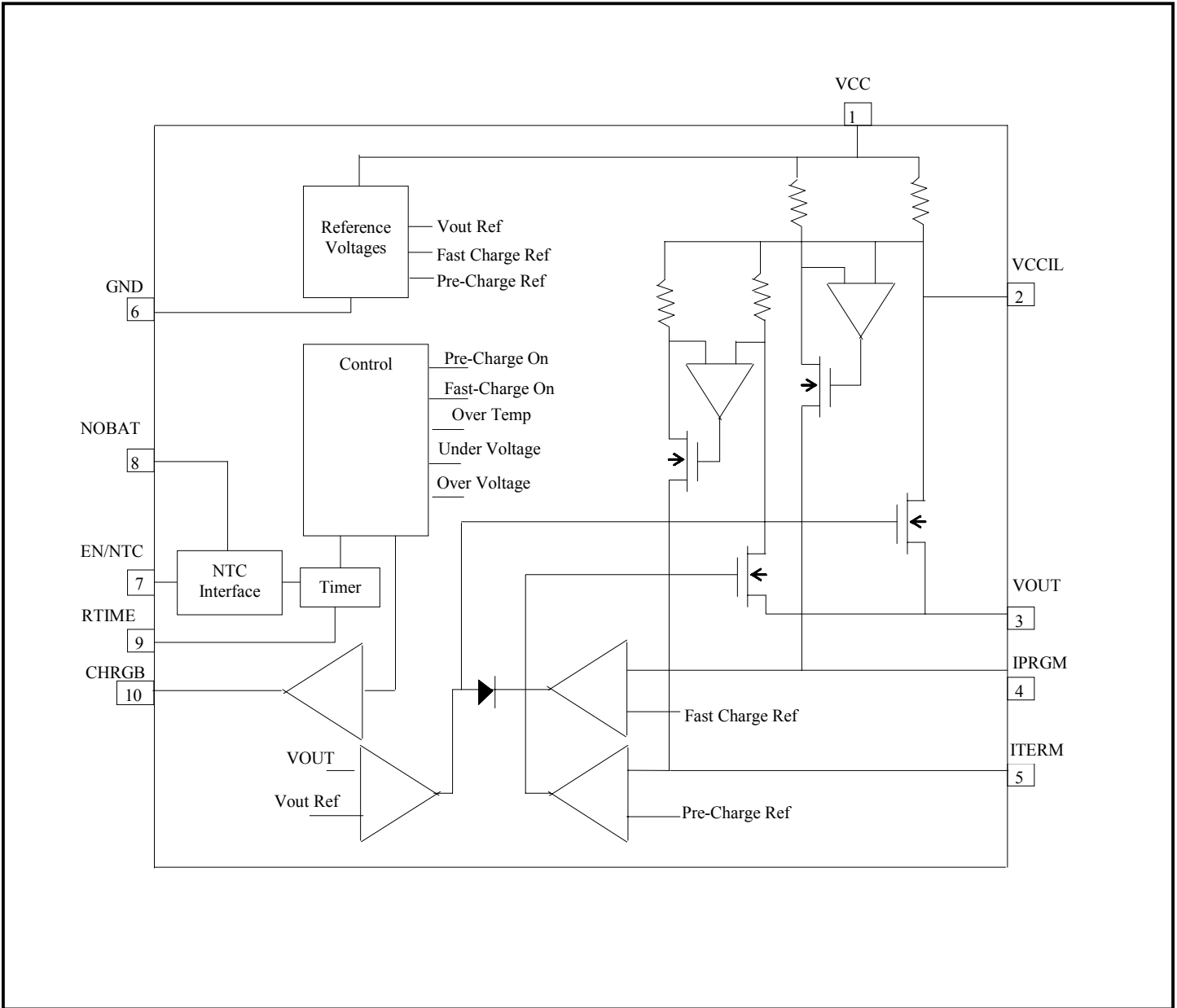
POWER MANAGEMENT
Block Diagram

POWER MANAGEMENT
Applications Information
General Operation

The SC805 is configured based on the application for Fast Charge and Termination current, timing requirements, and operation with and without a battery (LDO mode). A typical charging cycle is described below. Details on alternate applications and output programmability are covered in the individual sections.

The charging cycle begins when the adapter is plugged in. The SC805 performs glitch filtering on the VCC input and initiates a charge cycle when $VCC > UVLO$. At this time, the CHRGB signal is active low turning on the charging LED. If the battery voltage is less than 2.8V, the SC805 will charge the output with the pre-charge current. When the battery voltage exceeds 2.8V, the SC805 enters fast-charge or constant current (CC) mode. When the battery voltage reaches its final value, the charger enters the constant voltage (CV) mode. In this mode the output current decreases as the battery continues to charge until the termination current level is reached.

The CHRGB pin goes high when Iout is less than Itermination turning off the 'charging' LED and turning on the 'charge complete' LED. The SC805 continues to hold the battery in CV charge mode until the timer expires. At this point the charger enters the monitor mode where the output remains off until Vout drops by 100mV and a new charge cycle is initiated.

Pre-Charge Mode

Pre-charge mode is automatically enabled whenever the battery voltage is below 2.8V. It is used to limit the power dissipation and precondition the battery for fast charging. The pre-charge current value is selected by the resistor on the ITERM pin. The pre-charge current is programmable from 10mA to 125mA. The equation to select the pre-charge current is given by:

$$PCI = \left(\frac{1.5}{R_{TERM}} \right) \cdot 100$$

If the charge timer is in use there is also a maximum allowed pre-charge duration. If the pre-charge time exceeds 1/4 of the total charge cycle the charger will turn off due to a pre-charge fault. This fault is cleared when EN or VCC is toggled or the output voltage rises above 2.8V.

Fast-Charge Mode (CC)

The fast-charge or CC mode is active when the battery voltage is above 2.8V and less than the CV or final float charge voltage of the battery. The fast-charge current can be set to a maximum of 1.0A and is selected by the program resistor on the IPRGM pin. The voltage on this pin will represent the current through the battery enabling a microprocessor via an analog-to-digital converter (ADC) to monitor battery current by sensing the voltage on the IPRGM pin. The equation to set the fast-charge current is given by:

$$FCI = \left(\frac{1.5}{R_{PRGM}} \right) \cdot 1000$$

Note that for a given program resistor the current through the battery in CV mode can be determined by replacing 1.5 with the actual voltage on the IPRGM pin in the above equation.

The superior fast-charge current accuracy of the SC805 is obtained by use of a patented* polarity-switched (i.e., chopped) current sense amplifier to nullify current measurement offset errors.

Termination Current

Once the battery reaches the program voltage of 4.2V the device will transition from a constant current source to a constant voltage source and the current through the battery begins to decrease while the voltage remains constant. When the current falls below the programmed termination current set by the termination resistor on the ITERM pin, the SC805 will transition the CHRGB pin from low to high. If the timer is enabled the output will continue to float charge in CV mode until the timer expires. If the timer is disabled then the output will turn off as soon as the termination current level is reached. If the part is in LDO mode the SC805 will remain on indefinitely at the regulated CV voltage. The equation to set the termination current is given by:

$$ITERM = \left(\frac{1.5}{R_{TERM}} \right) \cdot 100$$

Monitor Mode

When a charge cycle is completed, the SC805 output turns off and the device enters monitor mode. If the voltage of the battery falls below the recharge threshold

*US Patent 6,836,095

POWER MANAGEMENT
Applications Information (Cont.)

of CV-100mV the charger will clear the charge timer and re-initiate a charge cycle. The maximum current drain of the battery during monitor mode will be no more than 1µA over temperature. The status of the charger output as a function of RTime, and IOUt is shown below.

Output State	Rtime	Timer	Iout
On	VCC	N/A	N/A
On	R	T < Timer	N/A
Off	R	T > Timer	N/A
On	Low	Disabled	> Itermination
Off	Low	Disabled	< Itermination

Charge Timer

The timer on the SC805 is used as protection in the case of a faulty battery and to maximize charging capacity. Connect a resistor from the RTIME pin to GND to select the desired charge time duration according to the following equation.

$$\text{Charge Time} = \left(\frac{R_{\text{TIME}}}{39.2k} \right) \cdot 2.5\text{hrs}$$

The timer is programmable over the range of 1 to 10 hrs. To disable the charge timer connect RTIME to GND. Driving the RTIME pin to VCC will disable the timer and select LDO-mode operation for the SC805. One implementation of this feature is discussed in the NOBAT operating section.

The SC805 will automatically turn off the output when the charge timer times out.

NOBAT output

The SC805 detects the absence of the battery by monitoring the voltage on the NTC pin. When the NTC pin voltage exceeds 95% of VCC the NOBAT output is driven high. This function utilizes the standard NTC configuration with the NTC component residing in the battery pack. When the battery is removed the NTC element in the resistor divider is missing and the NTC voltage is pulled up to VCC.

The NOBAT output can be used to signal the system that the battery has been removed, drive an external LED, or fed back to the SC805 to select LDO-mode.

Connect the NOBAT pin to the RTIME pin to select LDO mode when the battery is removed and re-enable the output of the SC805.

LDO Mode

The SC805 is designed to work with or without a battery. If the battery is not in place the device can enter LDO mode. In this mode the SC805 will act like a low dropout regulator. The input pin RTIME is used to select LDO mode. If RTIME is high the device will be in LDO mode. When LDO-mode is selected and the EN-NTC pin is greater than 90% of VCC the output will be on in LDO mode. During LDO mode the device will regulate the output voltage with a current limit set by the resistor tied to the IPRGM pin.

EN-NTC Interface

The Enable pin on the SC805 provides three functions; device disable, battery detection, and NTC temperature protection. It can be used to turn off the device by driving the pin to Ground. It can also be connected to an external resistor divider consisting of a resistor and an NTC Thermistor to disable the charge cycle when the temperature is out of range. If the pin is pulled to VCC the SC805 will signal a 'No Battery' condition on the NOBAT pin. Note that the SC805 will be disabled due to the NTC function when the 'No Battery' condition is detected due to the NTC feature. The NTC temperature fault can be overridden to re-enable the output of the charger for no battery conditions as described in the NOBAT section of the datasheet.

POWER MANAGEMENT
Applications Information (Cont.)

The NTC external component configuration is shown in the typical application schematic on page 1 of the datasheet. When the NTC voltage from the divider is above or below the cold and hot temperature threshold values the SC805 will suspend the charge cycle by turning off the output, freezing the charge timer, and indicating a fault on the CHRGB LED. Hysteresis is included for both hot and cold thresholds to avoid chatter at the NTC trip points. When the temperature returns to the valid range the SC805 will automatically resume the charge cycle. The charge timer will time-out when the SC805 output on-time exceeds the timer setting regardless of how long it has been disabled due to the NTC temperature. The internal NTC thresholds of 30% and 75% VCC were designed to work with Curve-2 type thermistors available from numerous vendors.

Design Example based on the typical application schematic of page 1 using a Curve 2 Vishay-Dale NTC.

Thot = 50°C

Tcold = 0°C

Find R2 and RT1

Step 1: Pick an RT1 value high enough to prevent self-heating.

$$RT1 \geq \frac{(V(RT1))^2}{DC}$$

In general lower values of RT1 provide more noise immunity for the NTC voltage at the expense of bias current from the input adapter. The dissipation constant DC is the power rating of the NTC resulting in a 1°C self heating error.

The DC value for this NTC is 3mW and the voltage across the NTC is 2.5V for a 5V adapter. Therefore RT1 > 2K,

Set RT1 = 10k

Step 2: Find R2 to set the correct Hot level trip point,

$$R2 = 2.33 \cdot \left(R_{T25} \cdot \left(\frac{R_{T50}}{R_{T25}} \right) \right) = 9.52k$$

The closest standard resistor value is 9.53k. RT(temp)/RT(25°C) is often referred to as the ratio at the given temp. For this NTC at 50°C the ratio is 0.4086.

Step 3: Calculate the Tcold value.

$$\left(\frac{RT_{COLD}}{RT_{25}} \right) = 3 \cdot \left(\frac{R2}{10K} \right) = 2.86$$

The ratio for the curve 2 NTC at 0°C is 2.816. The difference represents less than 1/2°C (i.e., actual trip would be -0.5°C instead of 0°C.) For temperature trip values other than 0°C and 50°C alternate curve-type NTC elements can be used or an additional resistor can be added to the Rntc divider to alter the temperature coefficient.

CHRGB LED Flag

The CHRGB LED driver on the SC805 can be used to drive two external LEDs: CHRGB=Low (Charging) and CHRGB=High (Charge Complete). The CHRGB output will be high impedance when the VCC is in a UV condition. The Table below defines the CHRGB LED output states.

LED	High	Low	High-Z	Blinking
CHRGB	Iout < Iterm	Iout > Iterm	VCC < UV	PreCharge OV or NTC Fault

The CHRGB output can be used for a VCC indicator. When the SC805 is enabled the CHRGB output is either high or low providing the VCC input is above UVLO.

The CHRGB output signifies the charging status. When the output current is > Itermination, CHRGB=low. CHRGB is high when Iout is < Itermination. The CHRGB output is latched high at the end of the charge cycle when the output current is less than Itermination. The CHRGB output will remain high until the timer expires and vbatt enters a re-charge cycle, or if EN, or VCC are toggled.

POWER MANAGEMENT
Applications Information (Cont.)

The CHRGB indicator operates the same way in both charge and LDO mode.

The CHRGB output can be used for a VCC indicator. When the SC805 is enabled the CHRGB output is either high or low providing the VCC input is above UVLO. Alternately an LED connected to VCCIL can be used for a VCC indicator as shown in the typical application schematic on the front page of the datasheet.

There are five fault modes detected by the SC805; (Input under voltage, input over voltage, NTC temperature, Max die temperature or OT and pre-charge timeout). The LED states for these fault modes are shown below.

Fault	CHRGB
VCC UVLO	High-Z
VCC OVP	Blinking
NTC Fault	Blinking
Pre-Charge Time-out	Blinking
Tj > 150°C	Blinking

Overcurrent and Max Temperature Protection

Overcurrent protection is inherent in all modes of operation. When the device is in charge-mode the output is current limited to either the pre-charge current limit value or the fast charge current limit value depending on the voltage at the output. When the device is in LDO mode the output current is limited to the fast charge current limit. Max die temperature protection is included on the SC805. This feature allows the SC805 to operate with maximum power dissipation by disabling the output current when the die temperature reaches OT. The result is that the SC805 will operate as a pulse charger in extreme power dissipation applications delivering the maximum allowable output current while regulating the internal die temperature to a safe level.

Layout Guidelines

The two most critical aspects of the pcb layout are the power path and thermal layout. The power path starts at the Adapter + input and runs to the VCC input of the SC805, then from the Vout pin of the SC805 to the Battery + terminal, and completes with the return trace from the battery - terminal to the adapter - input. All of these traces need to be designed to handle the required charging current. The trace from Vout of the SC805 is most critical and should be made as wide as possible to minimize IR drops between the regulated voltage at the SC805 vout pin and the battery terminal. Keep the Adapter+ to SC805 VCC input trace wide to minimize voltage drops that will add to the dropout voltage of the SC805. The GND pin of the SC805 should be connected in a kelvin fashion at the Battery-terminal to eliminate voltage drops in the return path which reduce the regulated battery voltage.

The thermal performance of the SC805 package requires a low impedance connection from the heat slug on the bottom of the package to an external ground plane. This is best accomplished by using a single large via under the device connected to a ground plane on the bottom exposed side of the pcb. The evaluation board uses 1 square inch of copper on the bottom of the pcb and is capable of 1A charging current.

The input and output bulk decoupling capacitors for the SC805 should be placed near the external terminals for the adapter and battery. This short low impedance loop is for the high current spikes that result from input/output hot-plugging of the charger. To minimize these current spikes the value of the decoupling capacitor should be minimized. A typical application requires a 0.1µF input/output capacitor. If the distance from the external terminals to the SC805 is greater than 1", 0.1µ local decoupling capacitors at the SC805 may be required.

POWER MANAGEMENT

Evaluation Board Schematic

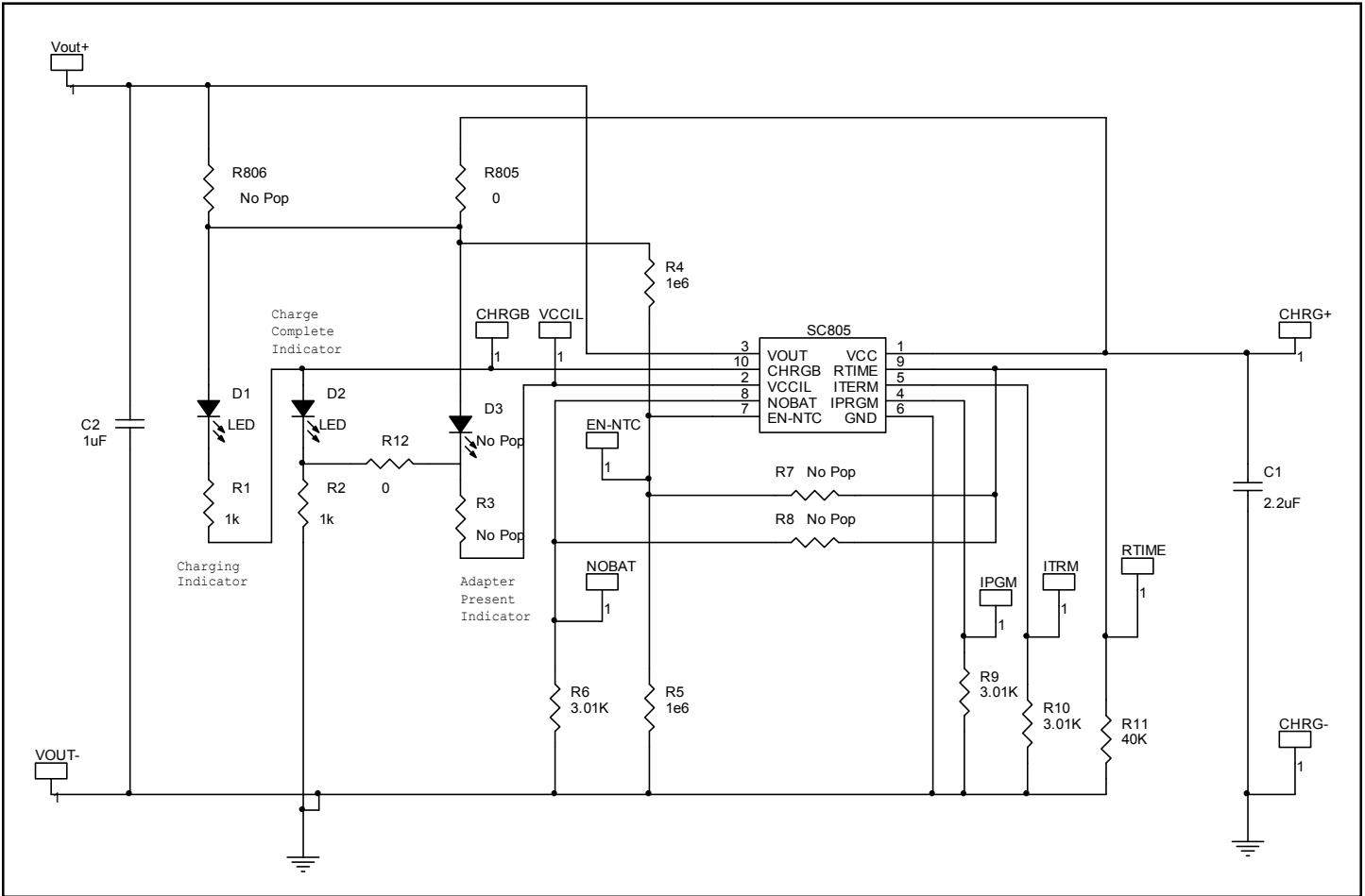

POWER MANAGEMENT

Typical Characteristics

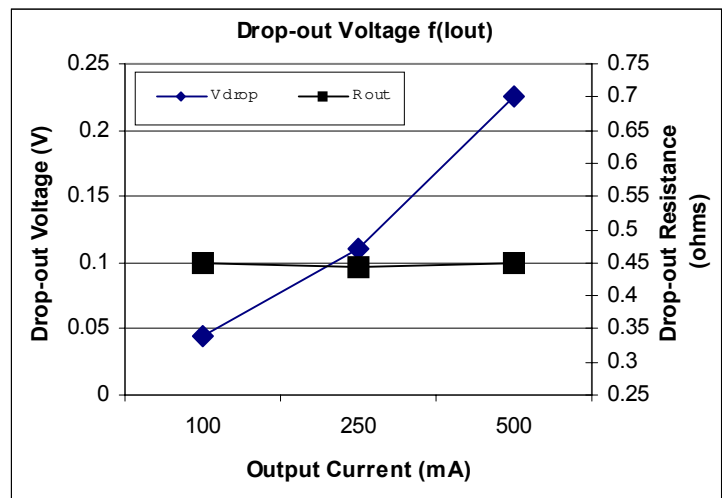
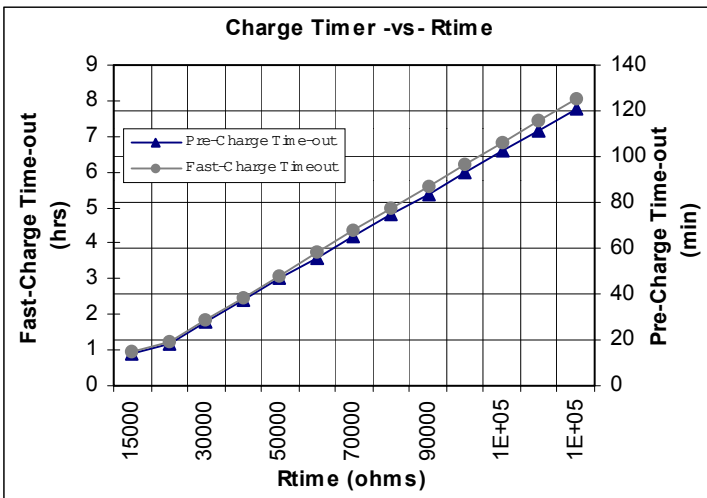
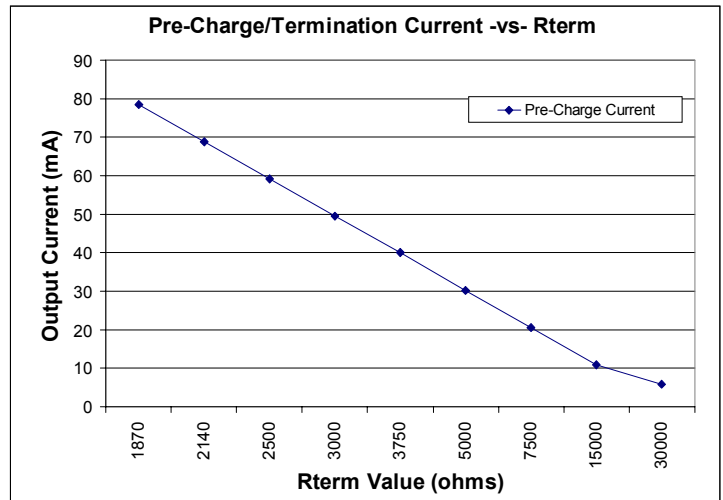
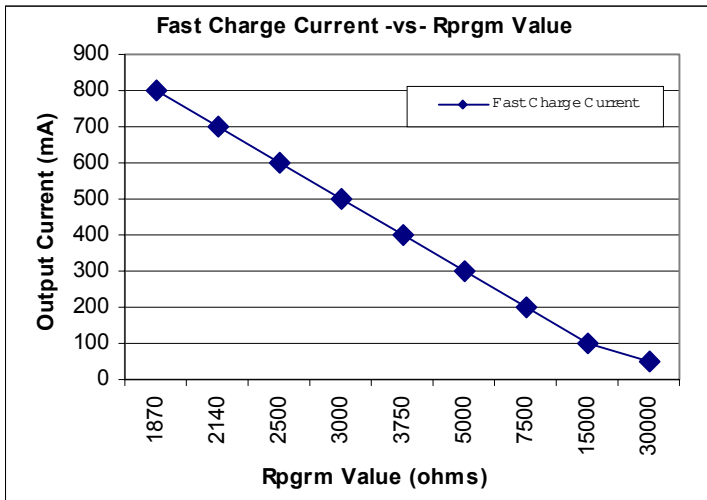
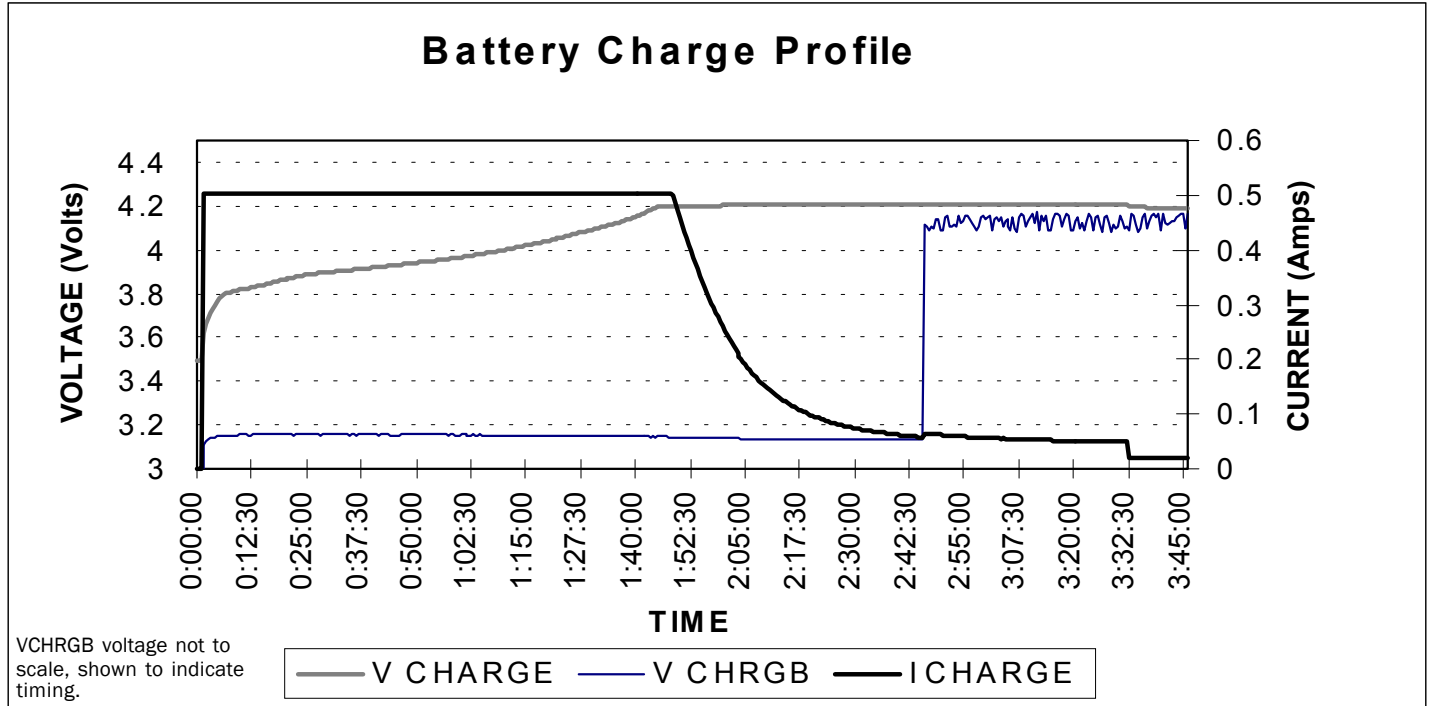

POWER MANAGEMENT

Typical Characteristics (Cont.)

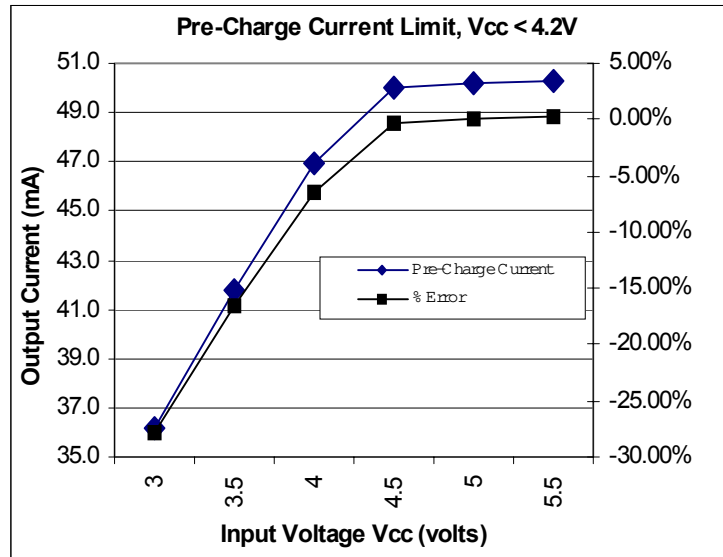
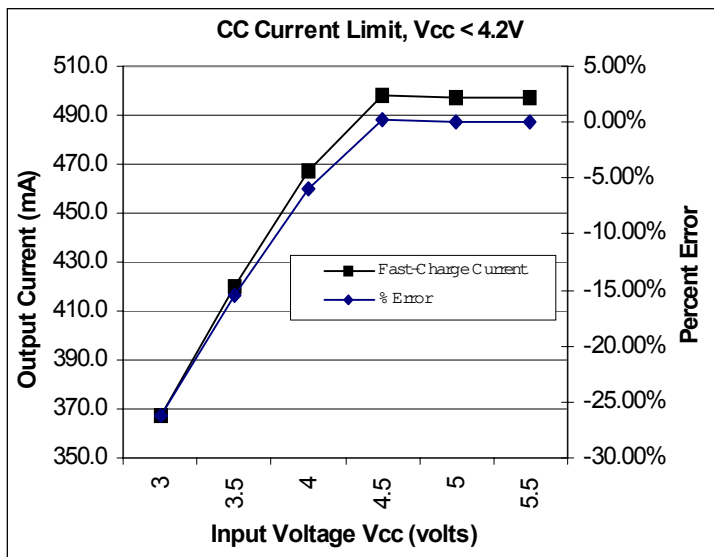
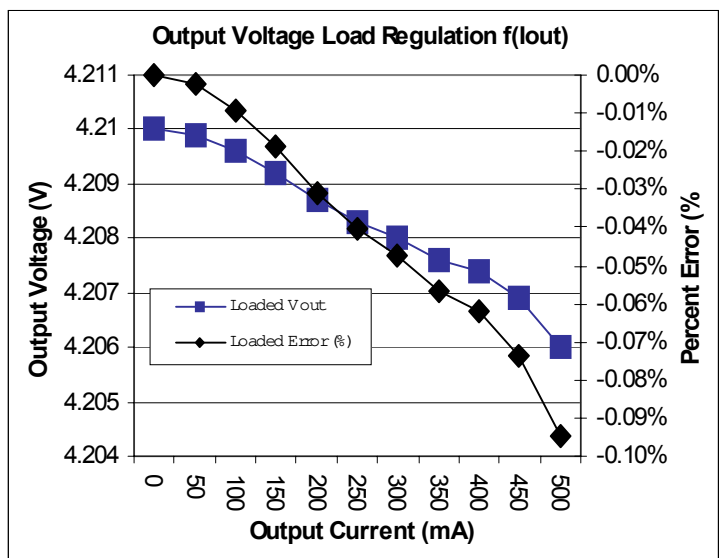
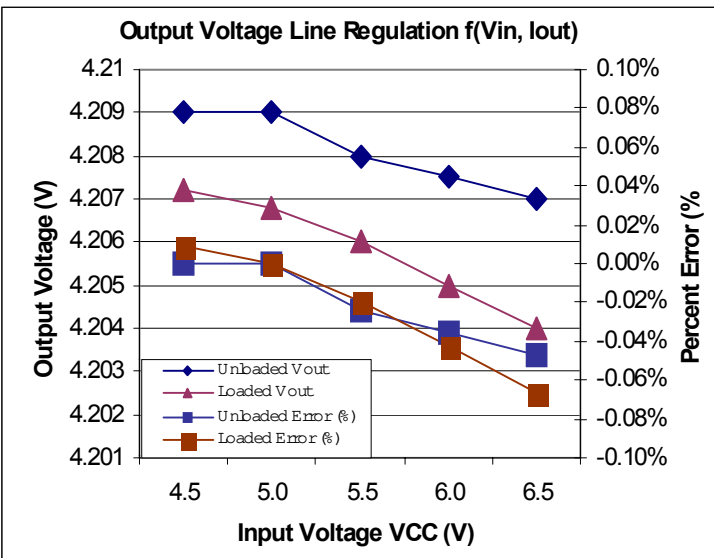
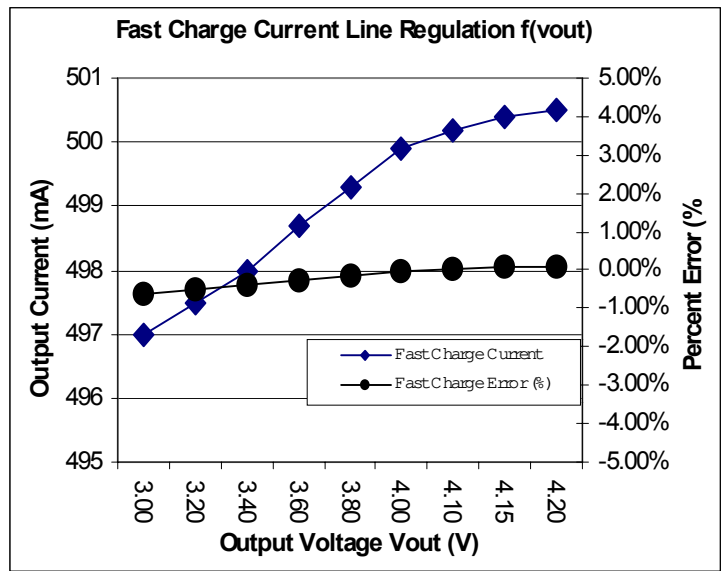
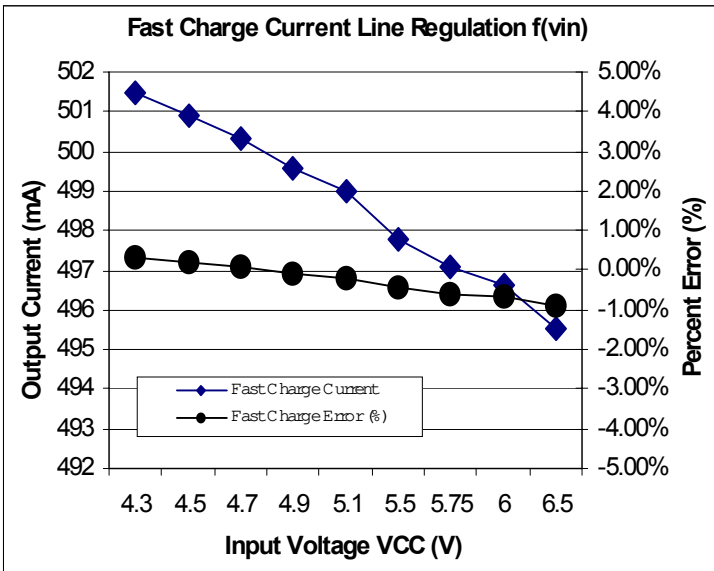

POWER MANAGEMENT

State Diagram

Under Voltage will force the SC805 into Shutdown Mode from any state.

Over Voltage will disable the output, suspend the timer, and blink CHRGB

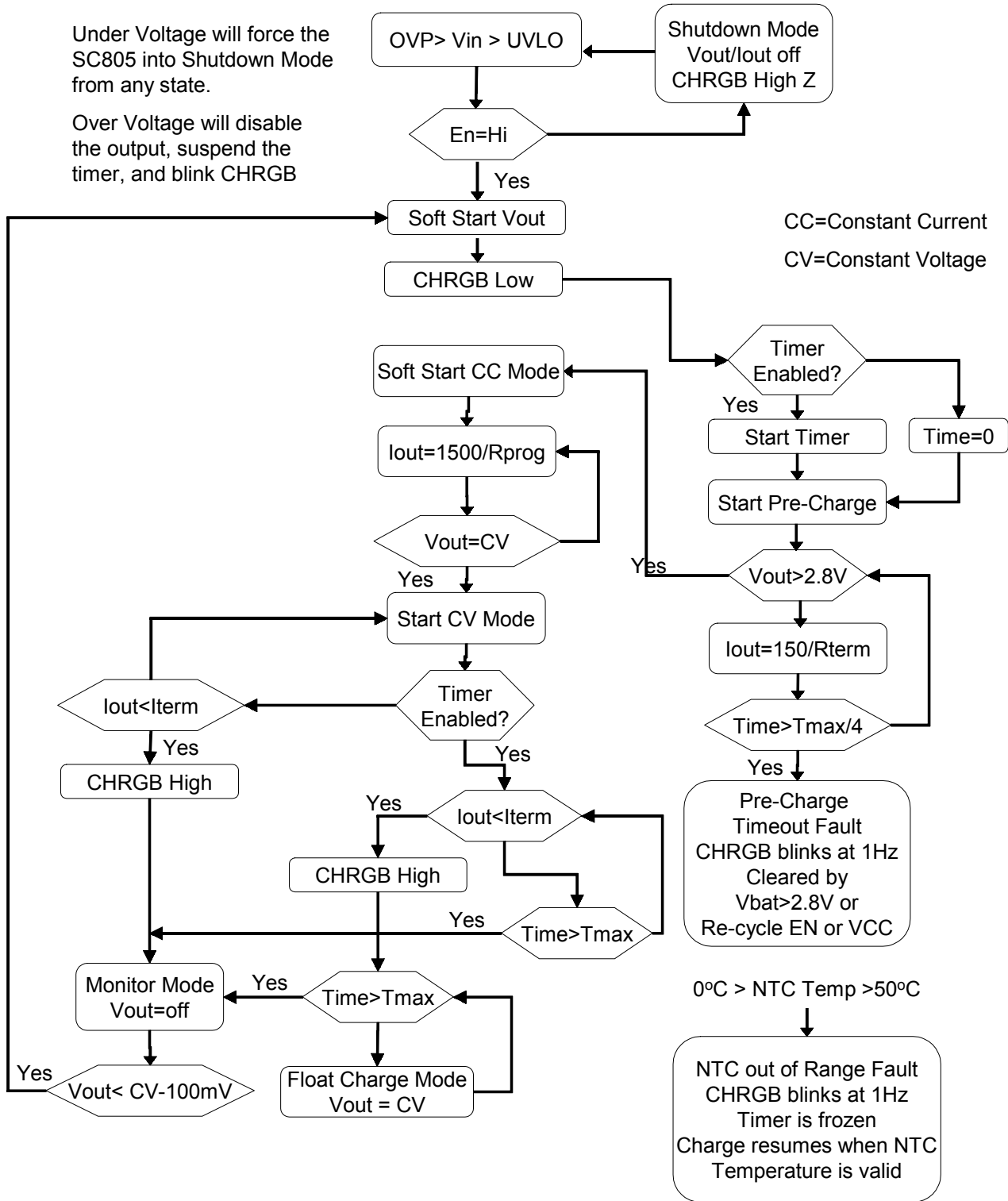

POWER MANAGEMENT

Outline Drawing - MLP3x3-10

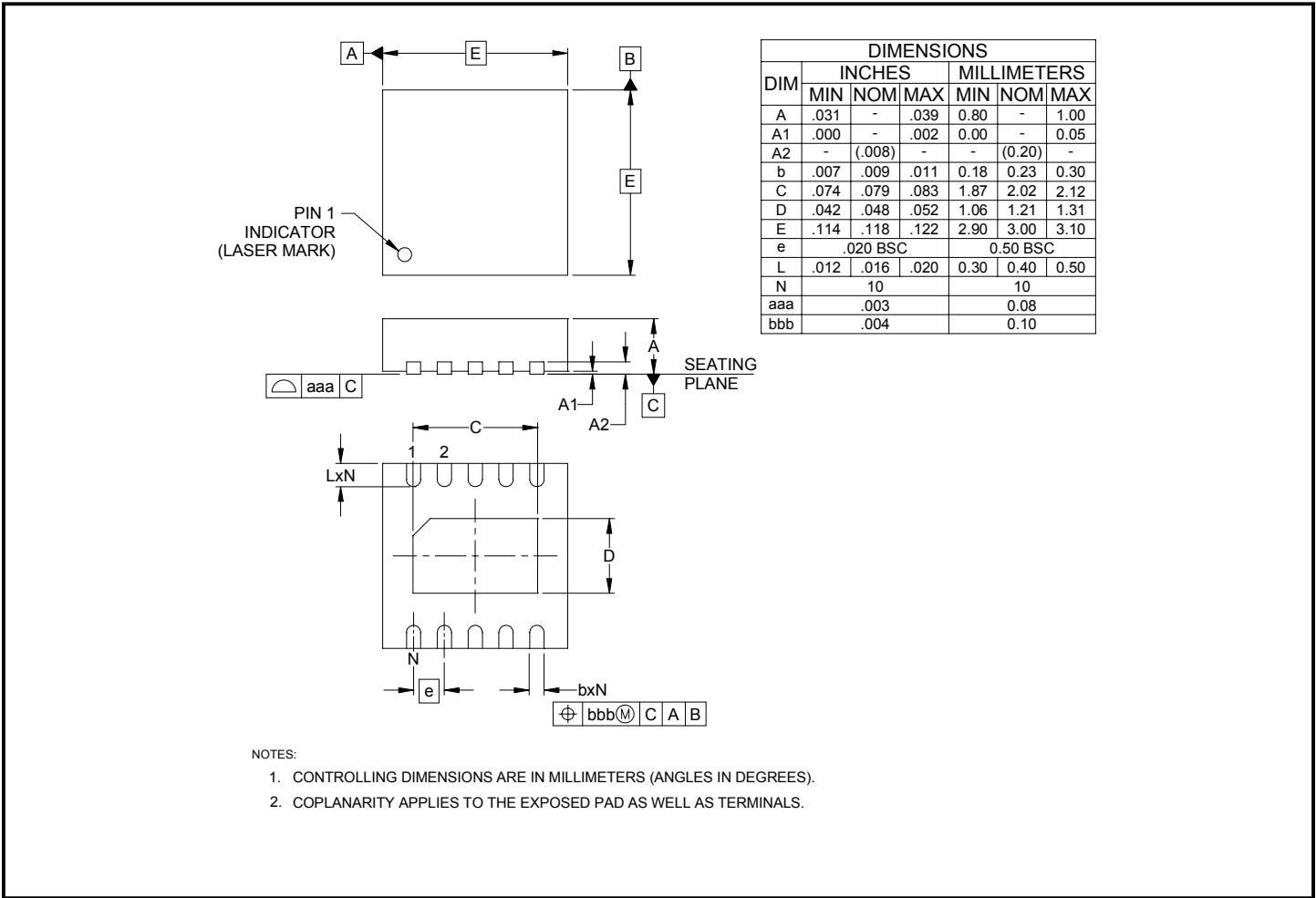

Marking Information



POWER MANAGEMENT

Land Pattern - MLP3x3-10

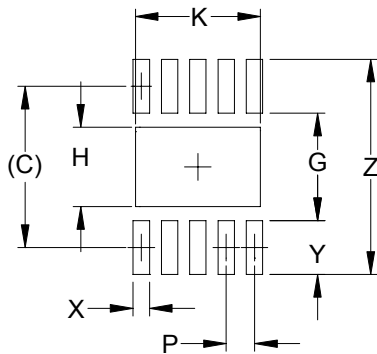

DIMENSIONS		
DIM	INCHES	MILLIMETERS
C	(.112)	(2.85)
G	.075	1.90
H	.055	1.40
K	.087	2.20
P	.020	0.50
X	.012	0.30
Y	.037	0.95
Z	.150	3.80

NOTES:

1. THIS LAND PATTERN IS FOR REFERENCE PURPOSES ONLY. CONSULT YOUR MANUFACTURING GROUP TO ENSURE YOUR COMPANY'S MANUFACTURING GUIDELINES ARE MET.

Contact Information

Semtech Corporation
 Power Management Products Division
 200 Flynn Road, Camarillo, CA 93012
 Phone: (805)498-2111 FAX (805)498-3804