



Chipsmall Limited consists of a professional team with an average of over 10 year of expertise in the distribution of electronic components. Based in Hongkong, we have already established firm and mutual-benefit business relationships with customers from,Europe,America and south Asia,supplying obsolete and hard-to-find components to meet their specific needs.

With the principle of “Quality Parts,Customers Priority,Honest Operation,and Considerate Service”,our business mainly focus on the distribution of electronic components. Line cards we deal with include Microchip,ALPS,ROHM,Xilinx,Pulse,ON,Everlight and Freescale. Main products comprise IC,Modules,Potentiometer,IC Socket,Relay,Connector.Our parts cover such applications as commercial,industrial, and automotives areas.

We are looking forward to setting up business relationship with you and hope to provide you with the best service and solution. Let us make a better world for our industry!



Contact us

Tel: +86-755-8981 8866 Fax: +86-755-8427 6832

Email & Skype: info@chipsmall.com Web: www.chipsmall.com

Address: A1208, Overseas Decoration Building, #122 Zhenhua RD., Futian, Shenzhen, China



POWER MANAGEMENT

Description

The SC806 is a fully integrated, single cell, constant-current (cc)/constant-voltage (cv) Lithium-Ion battery charger in a tiny 3x3 mm thermally enhanced MLP package. The SC806 can operate as a stand-alone charger or in conjunction with a Power Management Controller (PMIC).

The SC806 has a pre-charge function for trickle charging deeply discharged batteries. The fast charge current is enabled automatically when the battery voltage reaches the required threshold. When the battery reaches the constant voltage or CV portion of the charge curve the SC806 switches to CV regulation mode. In this mode the output current decays until the termination current is reached. At this point the SC806 signals the charge cycle is complete and turns off the output and enters the monitor mode. If the battery voltage drops by 100mV from the CV voltage a new charge cycle will begin.

The SC806 can also function as a general purpose current source or as a current source for charging Nickel-Cadmium (NiCd) and Nickel-Metal-Hydride (NiMH) batteries.

Features

- ◆ Fully integrated charger with FET pass transistor, reverse-blocking diode, sense resistor and thermal protection
- ◆ High Accuracy Charge Current*
- ◆ Tiny 3mm x 3mm 10 lead MLP package
- ◆ Programmable precharge, fastcharge and termination current
- ◆ Battery voltage controlled to 1% accuracy
- ◆ Battery Charge Current accurate to 5% at 800mA
- ◆ Soft-start for step load and adapter plug-in
- ◆ Up to 1A continuous charge current
- ◆ Input voltage range from 3V to 6V allows seamless charging from current limited adapter
- ◆ 0.1µA battery drain current in shutdown and monitor modes
- ◆ Over current protection in all charging modes
- ◆ Automatic loss of battery detection
- ◆ Adapter Present, Charge Status, and No Battery output LED drivers

*Patent Pending

Applications

- ◆ Cellular phones
- ◆ PDAs
- ◆ Handheld meters
- ◆ Charging stations
- ◆ USB chargers
- ◆ Digital cameras
- ◆ GPS Handhelds
- ◆ Programmable current source

Typical Application Circuit

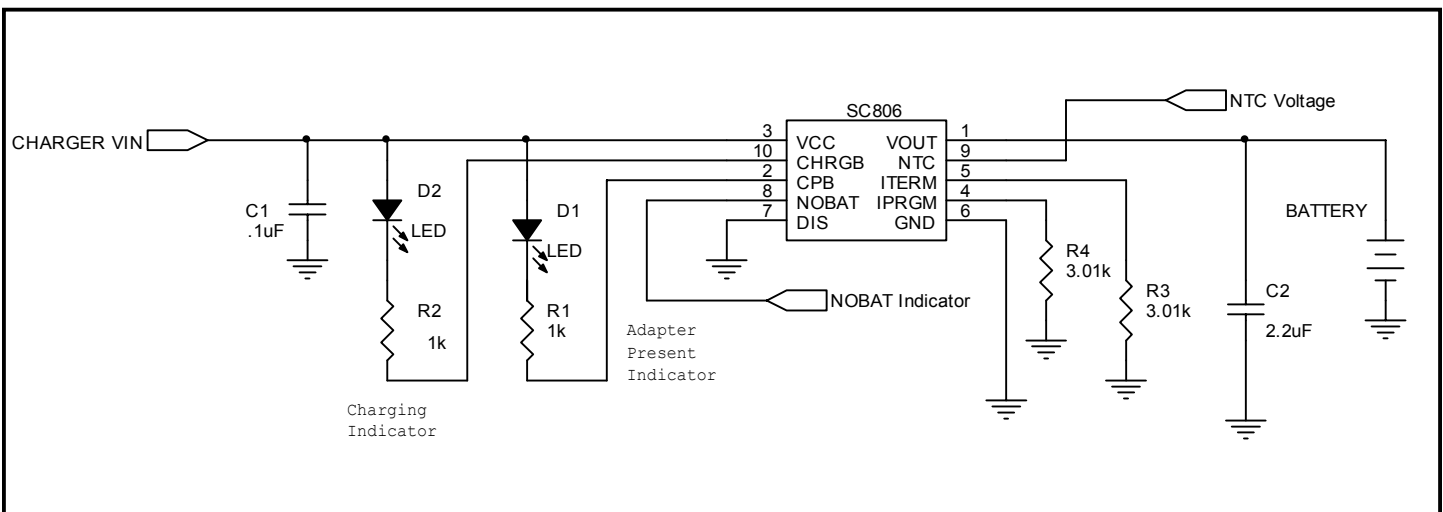

POWER MANAGEMENT
Absolute Maximum Ratings

Exceeding the specifications below may result in permanent damage to the device or device malfunction. Operation outside of the parameters specified in the Electrical Characteristics section is not implied.

Parameter	Symbol	Maximum	Units
VCC, CPB, CHRGB, NTC, DIS to GND		-0.3 to 7.0	V
VOUT, NOBAT, IPRGM, ITERM to GND		-0.3 to +6.0	V
Power Dissipation MLP (Derate 20mW/°C above 85°C)	Pd	2	W
Thermal Impedance, Junction to Case	θ_{JA}	50*	°C/W
Junction Temperature	Tjmax	150	°C
Operating Ambient Temperature Range	T _A	-40 to +85	°C
Peak IR Reflow temperature, soldering 20s-40s	T _{LEAD}	260	°C
Storage Temperature Range	T _{STG}	-65 to 150	°C
VOUT short to GND		Continuous	A
VOUT Output Current		1	A

*Calculated from package in still air, mounted to 3" x 4.5", 4 layer FR4 PCB with thermal vias under the exposed pad per JESD51 standards.

Electrical Characteristics

Unless otherwise noted: VCC = 4.75V - 5.25V.

Parameter	Symbol	Conditions	25°C			T _A (-40°C to +85°C)		Units
			Min	Typ	Max	Min	Max	
Input Voltage	VCC			5		3.15	6.3	V
Operating Current	ICC _{DIS}	Shutdown Mode DIS = 5V		850		400	1200	µA
	ICC _{CHG}	Charging Mode, CPB, CHRGB, ITERM, IPRGM = 0 µA		1.2		0.8	2.25	mA
Battery Leakage Current	Ileak _{BAT}	VCC = 0V		0.1			1	µA
Regulated Voltage	VBAT**			4.2		4.16	4.24	V
Battery Pre-Charge Current	IPREQ	ITERM Resistor R = 3.01k		50		45	55	mA
Battery Termination Current	ITERMQ			50		45	55	
Battery Fast-Charge Current	IFastQ ₁	IPRGM = 15k IPRGM = 1.87k VBATTERY = 3.8V		100		91.5	111.5	mA
	IFastQ ₂			787		-5	+5	%
Battery Fast-Charge Current Limit		2.8V < VBATTERY < VBAT Dropout Voltage = 1V					1.0***	A

POWER MANAGEMENT
Electrical Characteristics (Cont.)

Unless otherwise noted: VCC = 4.75V - 5.25V.

Parameter	Symbol	Conditions	25°C			T _A (-40°C to +85°C)		Units
			Min	Typ	Max	Min	Max	
Iprog Regulated Voltage	V _{IPRGM}			1.5		1.4	1.6	V
Iterm Regulated Voltage	V _{ITERM}			1.5		1.4	1.6	V
Vin UVLO Rising Threshold	VT _{UVLOR}			2.8		2.65	3.15	V
Vin UVLO Falling Threshold	VT _{UVLOF}			2.75		2.60	3.10	V
Vin UVLO Hysteresis	VT _{UVLOH}		20	50				mV
Vin OVP Rising Threshold	VT _{OVPOR}			6.8		6.3	7.5	V
Vin OVP Falling Threshold	VT _{OVPof}			6.4		5.9	7.15	V
Vin OVP Hysteresis	VT _{OVPoH}			400		150	600	mV
Vbat Precharge Threshold	VT _{PREQR}			2.8		2.7	2.9	V
Vbat Recharge Threshold	VT _{REQ}	VBAT - VBATTERY	60	100	140			mV
NTC Thresholds	VT _{NOBAT}	No Battery Detect Tested at Vcc=5V		95		93	96	%Vcc
DIS Threshold	VT _{DIS}	VCC=5V		1.0		0.4	1.25	V
Over Temperature Shutdown	OT	Hysteresis = 10°C		150				°C
CHRGB LED output	VCB _{VOL}	Charging Isnk=2mA		0.2			.5	V
	ICB _{OFF}	Charge Complete, Disable or UV off leakage		.1			1	μA
CPB LED output	VCP _{VOL}	Charger Present Isnk=2mA		0.2			.5	V
	ICP _{OFF}	UV off leakage		.1			1	μA
NoBat output	VNB _{VOH}	NTC=VCC, Isrc=1mA		4.8		4.5		V
	INB _{OFF}	NTC=VCC/2 off leakage		.1			1	μA

Notes:

 * Tied to PCB with 1 Square Inch, 2 Ounce Copper. T_{ja}=41°C/W using JESD 51 Standard.

** Iload=75mA. See typical performance curve for load regulation characteristics.

*** Thermally Limited.

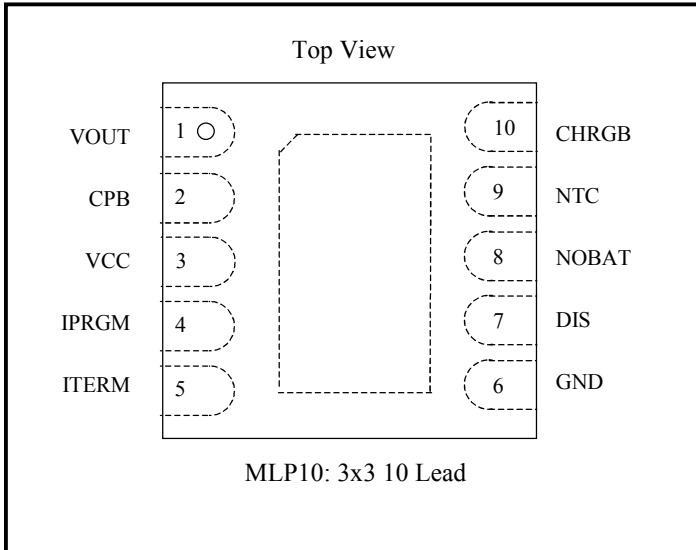
POWER MANAGEMENT
Pin Configuration

Ordering Information

Device ⁽¹⁾	Package
SC806IMLTRT ⁽²⁾	MLP-10
SC806EVB	Evaluation Board

Note:

(1) Only available in tape and reel packaging. A reel contains 3,000 devices.

(2) Available in lead-free packaging only. This product is fully WEEE and RoHS compliant.

Pin Descriptions

Pin #	Pin Name	Pin Function
1	VOUT	Charger output, connect to battery.
2	CPB	Output status indicator for the adapter present. This output is active low when the VCC input voltage is above the UVLO threshold.
3	VCC	Supply pin, connect to adaptor power.
4	IPRGM	Charger current limit program pin. Requires a resistor to ground to program fast-charge current.
5	ITERM	Selection for current termination and pre-charge current. Requires a resistor to ground to program pre-charge and termination current.
6	GND	Ground.
7	DIS	Device disable/enable pin. This pin is active low to enable the SC806, a high level disables operation.
8	NOBAT	Output status indicator for 'No Battery' condition. Output is active high when the battery is removed. Output is high impedance when the battery is present.
9	NTC	This pin is used to detect the NTC element inside the battery pack by detecting a voltage within 95% of VCC. Connect to resistor pullup to VCC and NTC to ground. This pin only controls the NOBAT output and does not effect the charger output.
10	CHRGB	Output status indicator. Active low output indicates charger is delivering current to the battery. CHRGB output goes high impedance when the output current falls below the termination current setting and the output is turned off. Connect cathode of the 'charging' LED this pin to indicate charge in progress.

POWER MANAGEMENT

Block Diagram

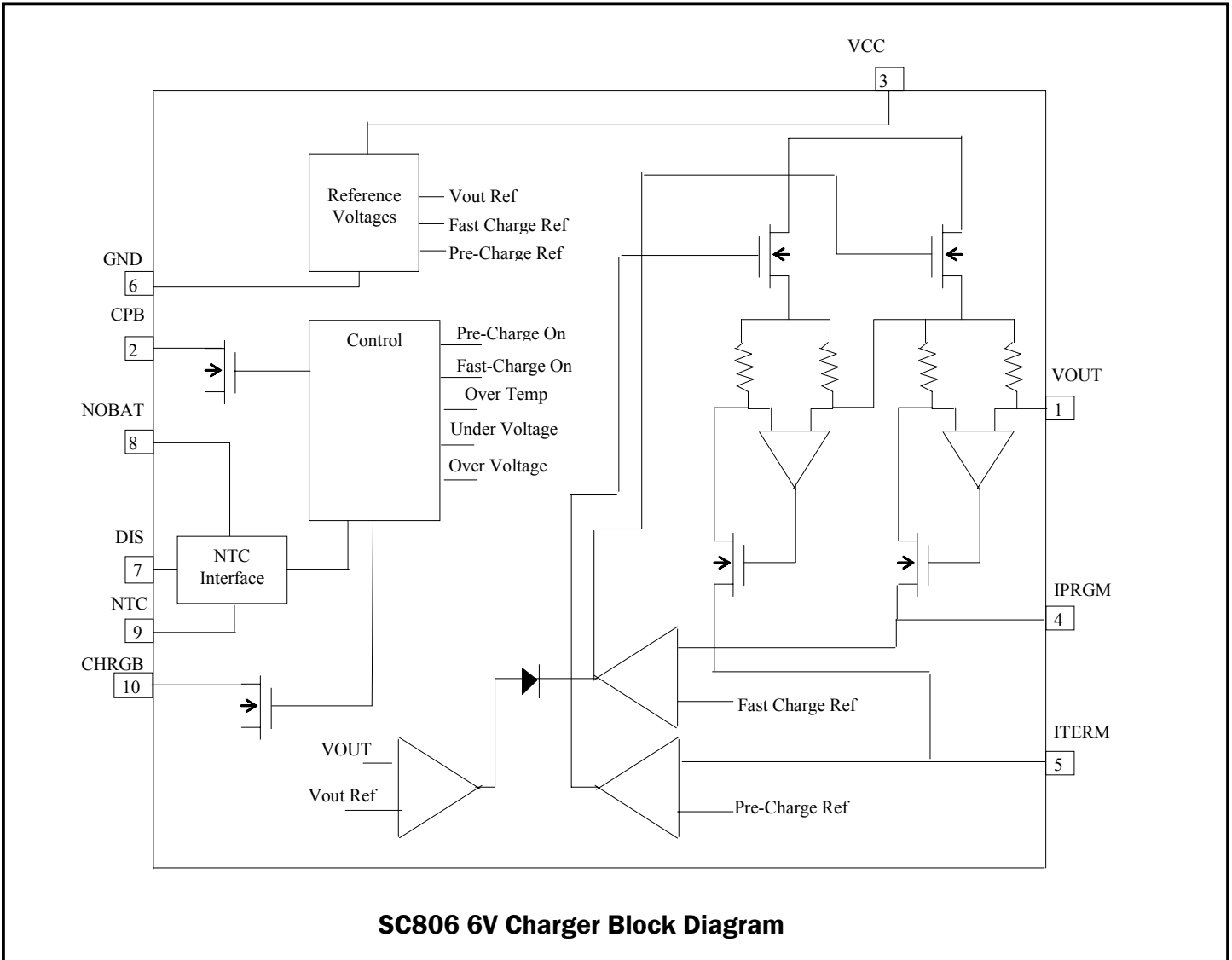

SC806 6V Charger Block Diagram

POWER MANAGEMENT
General Operation

The SC806 is configured based on the application for Fast Charge and Termination current. A typical charging cycle is described below. Details on alternate applications and output programmability are covered in the individual sections.

The charging cycle begins when the adapter is plugged in. The SC806 performs glitch filtering on the VCC input and initiates a charge cycle when $VCC > UVLO$. At this time, the CHRGB and CPB signals are active low turning on the LEDs. If the battery voltage is less than 2.8V, the SC806 will charge the output with the pre-charge current. When the battery voltage exceeds 2.8V, the SC806 enters fast-charge or constant current (CC) mode. When the battery voltage reaches its final value, the charger enters the constant voltage (CV) mode. In this mode the output voltage is held constant and the current decreases until the termination current level is reached.

At this point the charger enters monitor mode and the CHRGB output is high impedance. The charger output remains off in monitor mode until V_{out} drops by 100mV and a new charge cycle is initiated.

Pre-Charge Mode

Pre-charge mode is automatically enabled whenever the battery voltage is below 2.8V. It is used to limit the power dissipation and precondition the battery for fast charging. The pre-charge current value is selected by the resistor on the ITERM pin. The pre-charge current is programmable from 10mA to 125mA. The equation to select the pre-charge current is given by:

$$PCI = \left(\frac{1.5}{R_{TERM}} \right) \cdot 100$$

Fast-Charge Mode (CC)

The fast-charge or CC mode is active when the battery voltage is above 2.8V and less than the 4.2V CV voltage of the battery. The fast-charge current can be set to a maximum of 1.0A and is selected by the program resistor on the IPRGM pin. The voltage on this pin will represent the current through the battery enabling a micro-processor to monitor battery current by sensing the voltage on the IPRGM pin. The equation to set the fast-charge current is given by:

$$FCI = \left(\frac{1.5}{R_{PRGM}} \right) \cdot 1000$$

Note that for a given program resistor the current through the battery in CV mode can be determined by replacing 1.5 with the actual voltage on the IPRGM pin in the above equation.

Termination Current

Once the battery reaches the program voltage of 4.2V the device will transition from a constant current source to a constant voltage source and the current through the battery begins to decrease while the voltage remains constant. When the current falls below the programmed termination current set by the termination resistor on the ITERM pin, the SC806 will transition the CHRGB pin from low to high. The equation to set the termination current is given by:

$$ITERM = \left(\frac{1.5}{R_{TERM}} \right) \cdot 100$$

Monitor Mode

When a charge cycle is completed, the SC806 output turns off and the device enters monitor mode. If the voltage of the battery falls below the recharge threshold of 4.1V the charger will re-initiate a charge cycle. The maximum current drain of the battery during monitor mode will be no more than 1 μ A over temperature

NTC Input/NOBAT output

The SC806 detects the absence of the battery by monitoring the voltage on the NTC pin. When the NTC pin voltage exceeds 90% of VCC the NOBAT output is driven high. This function utilizes the standard NTC configuration with the NTC component residing in the battery pack. When the battery is removed the NTC element in the resistor divider is missing and the NTC voltage is pulled up to VCC.

The NOBAT output can be used to signal the system that the battery has been removed or drive an external LED.

DIS Device Disable Interface

The DIS pin on the SC806 is used to shutdown the SC806 charger. This pin must be pulled low to enable the charger, high will disable the charger (do not leave floating). The CPB output indicating the adapter input status is active regardless of the state of DIS.

POWER MANAGEMENT
CHRGB LED Flag

The CHRGB LED driver on the SC806 can be used to drive an LED and/or signal the system processor. CHRGB=Low (Charging) and CHRGB=High-Z (Charge Complete). The CHRGB output will be high impedance when the VCC is in a UV condition. The Table below defines the CHRGB LED output states.

LED	Low	High-Z	Blinking
CHRGB	$I_{out} > I_{term}$	$I_{out} < I_{term}$	OV or OT Fault

The CHRGB output signifies the charging status. When the output current is $> I_{termination}$, CHRGB=low. CHRGB is high impedance when I_{out} is $< I_{termination}$. The CHRGB output is latched high-Z at the end of the charge cycle when the output current is less than $I_{termination}$. The CHRGB output will remain high until the battery enters a recharge cycle, or if EN, or VCC are toggled.

There are three fault modes detected by the SC806; (Input under voltage, input over voltage, and Max die temperature or OT). The LED states for these fault modes are shown below.

Fault	CHRGB
VCC UVLO	High-Z
VCC OVP	Blinking
$T_j > 150^{\circ}\text{C}$	Blinking

Overcurrent and Max Temperature Protection

Overcurrent protection is inherent in all modes of operation. When the device is in charge-mode the output is current limited to either the pre-charge current limit value or the fast charge current limit value depending on the voltage at the output. Max die temperature protection is included on the SC806. This feature allows the SC806 to operate with maximum power dissipation by disabling the output current when the die temperature reaches OT. The result is that the SC806 will operate as a pulse charger in extreme power dissipation applications delivering the maximum allowable output current while regulating the internal die temperature to a safe level.

CPB LED Flag

The CPB LED driver on the SC806 is used to indicate that the adapter voltage is present at the input to the SC806. The CPB output is an active low output when the input voltage is greater than 3V. This feature is active regardless of the state of the DIS pin.

Layout Guidelines

The two most critical aspects of the pcb layout are the power path and thermal layout. The power path starts at the Adapter + input and runs to the VCC input of the SC806, then from the Vout pin of the SC806 to the Battery + terminal, and completes with the return trace from the battery - terminal to the adapter - input. All of these traces need to be designed to handle the required charging current. The trace from Vout of the SC806 is most critical and should be made as wide as possible to minimize IR drops between the regulated voltage at the SC806 vout pin and the battery terminal. Keep the Adapter+ to SC806 VCC input trace wide to minimize voltage drops that will add to the dropout voltage capability of the SC806. The GND pin of the SC806 should be connected in a kelvin fashion at the Battery terminal to eliminate voltage drops in the return path reducing the regulated battery voltage.

The thermal performance of the SC806 package requires a low impedance connection from the heat slug on the bottom of the package to an external ground plane. This is best accomplished by using a single large via under the device connected to a ground plane on the bottom exposed side of the pcb. The evaluation board uses 1 square inch of copper on the bottom of the pcb and is capable of 1A charging current.

The input and output bulk decoupling capacitors for the SC806 should be placed near the external terminals for the adapter and battery. This short low impedance loop is for the high current spikes that result from input/output hot-plugging of the charger. To minimize these current spikes should be minimized. A typical application requires a 0.1 μF input/output capacitor. If the distance from the external terminals to the SC806 is greater than 1", 0.1 μF local decoupling capacitors at the SC806 may be required.

POWER MANAGEMENT

Evaluation Board Schematic

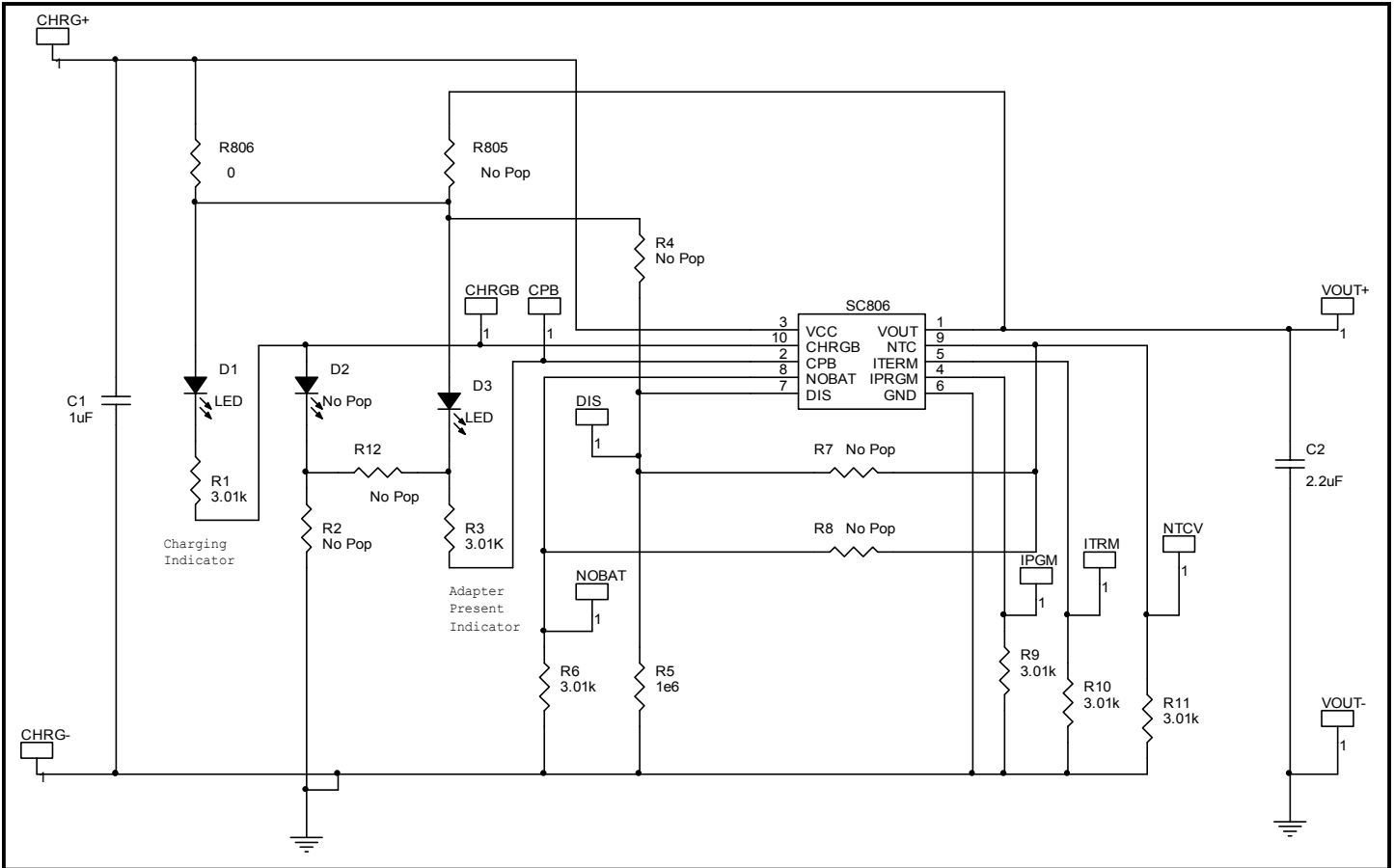

Timing Diagram

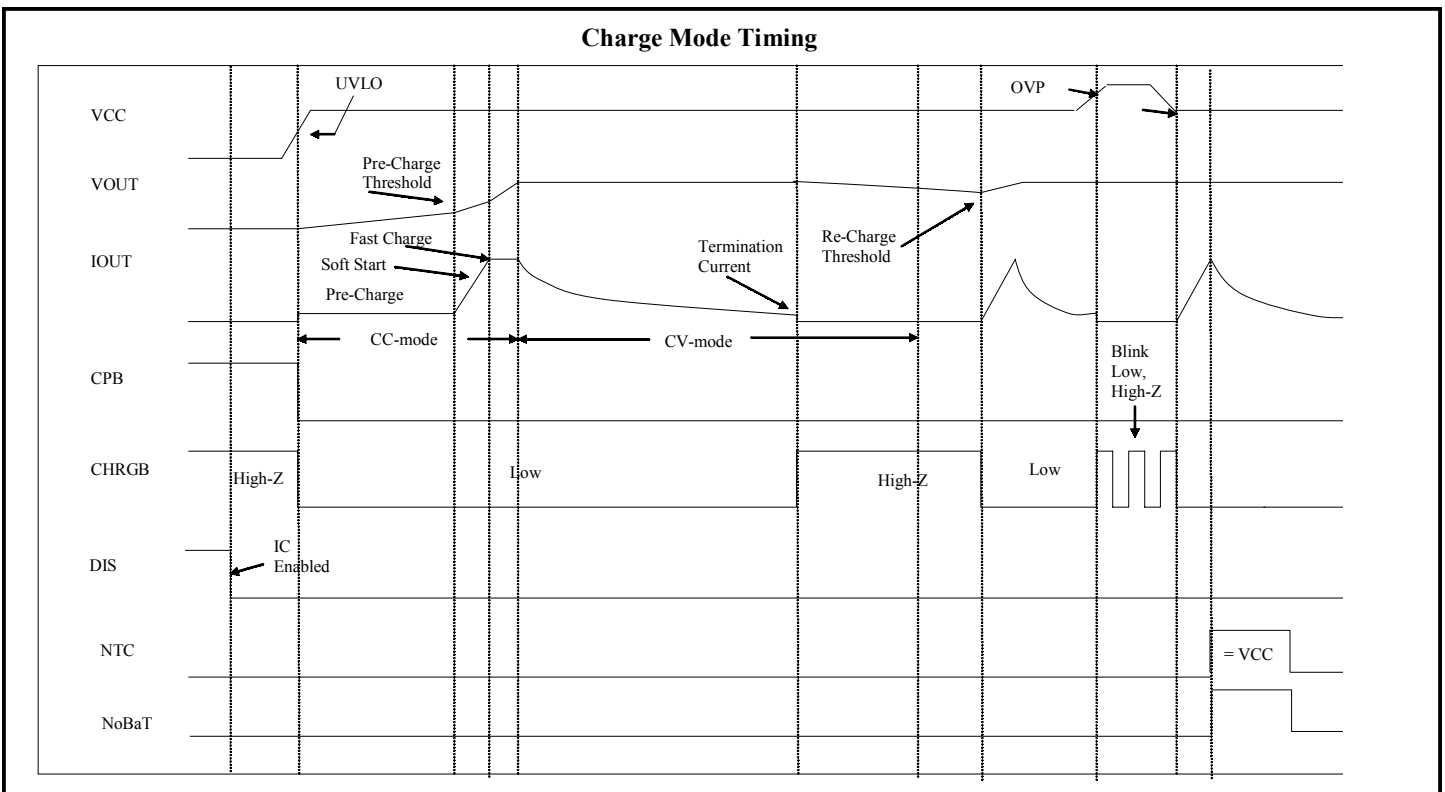

POWER MANAGEMENT

Typical Characteristics

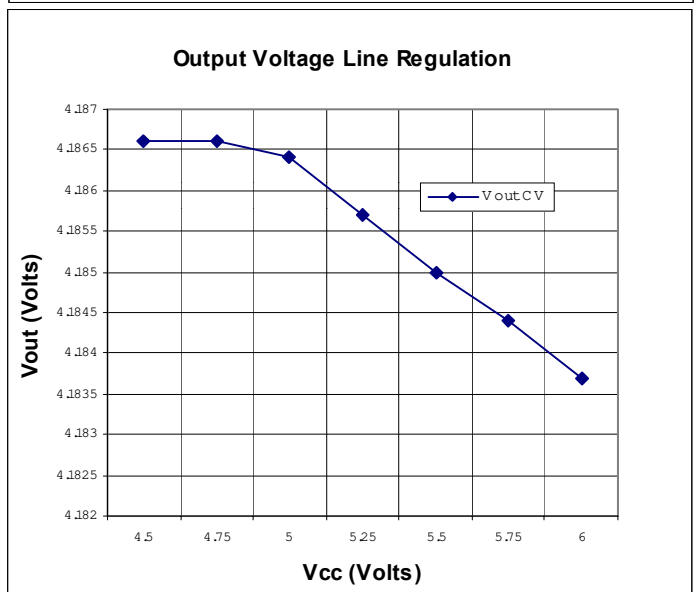
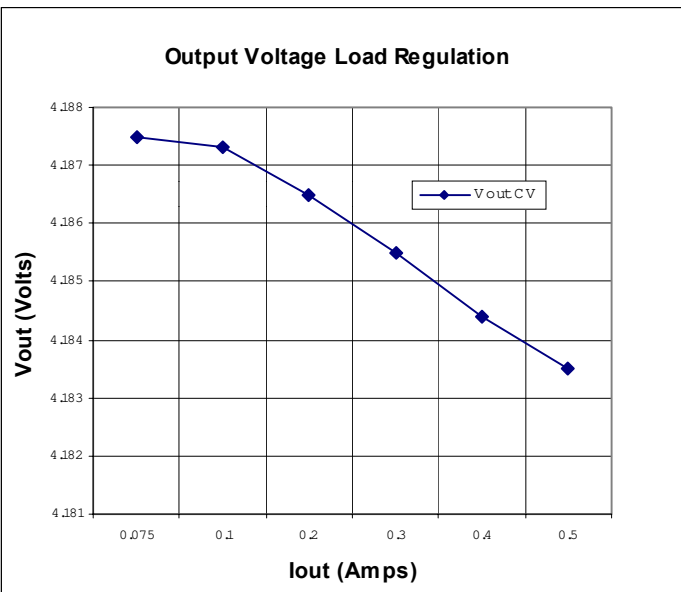
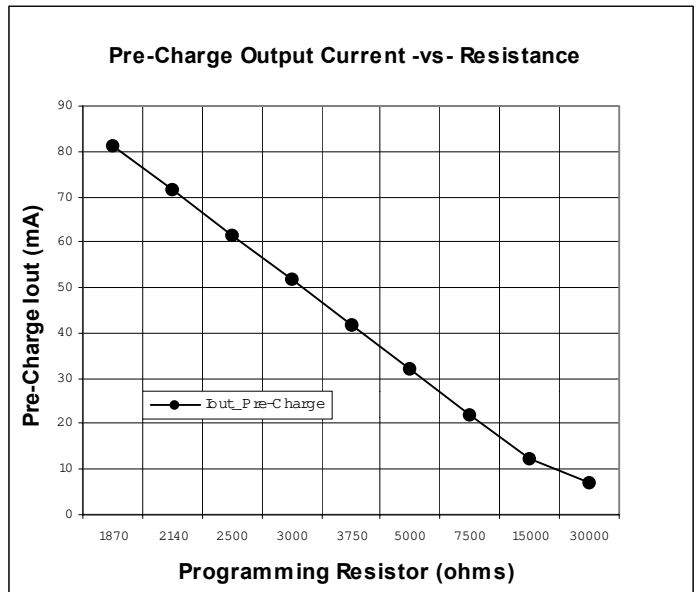
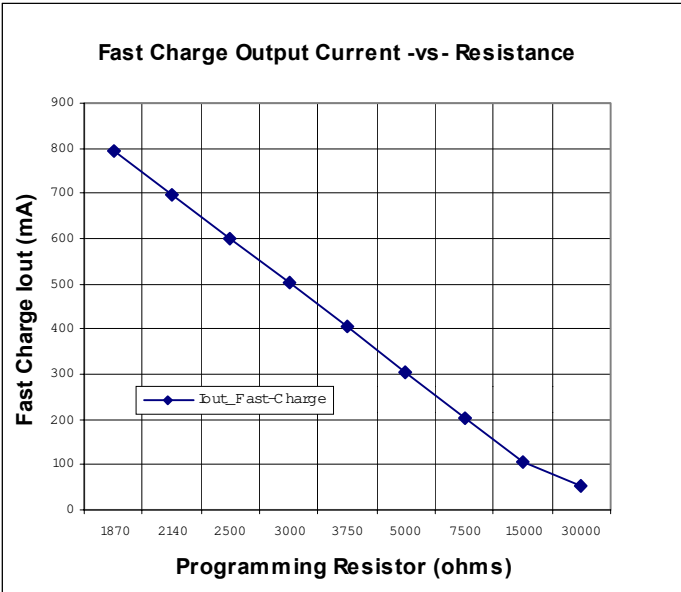
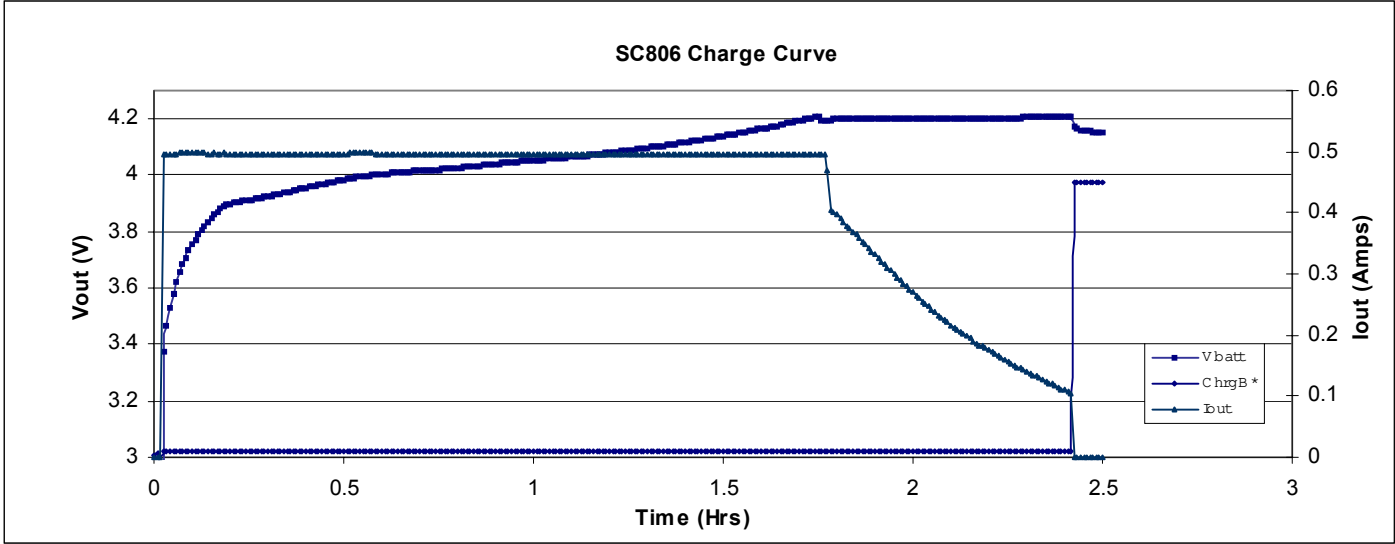

POWER MANAGEMENT

Typical Characteristics

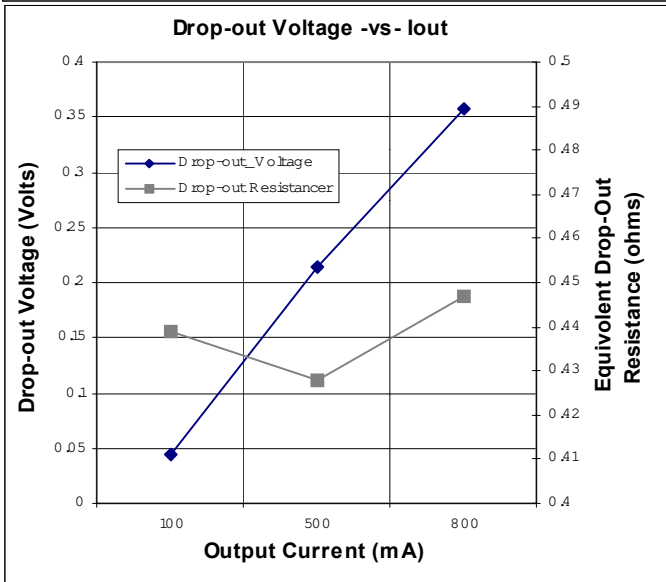
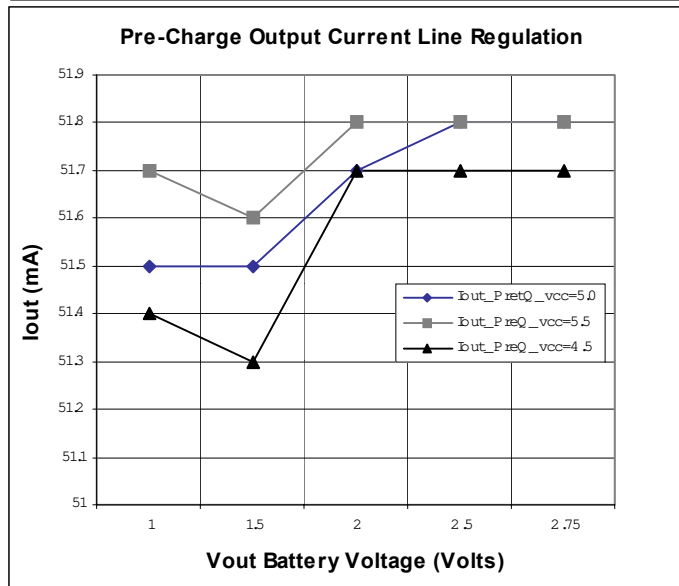
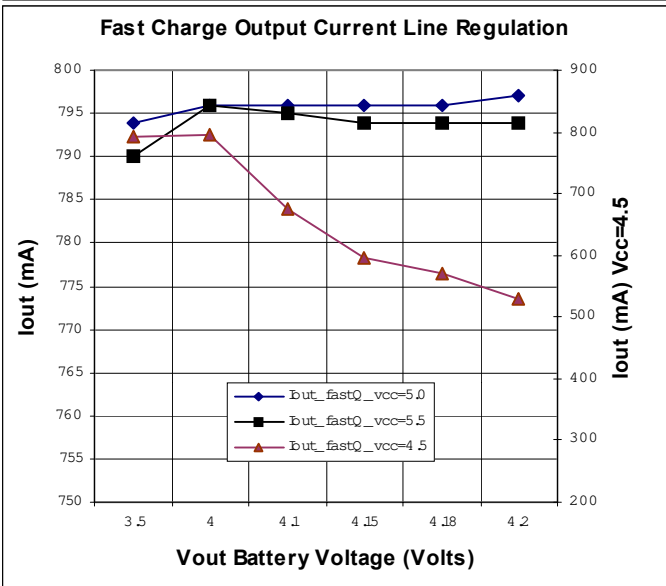
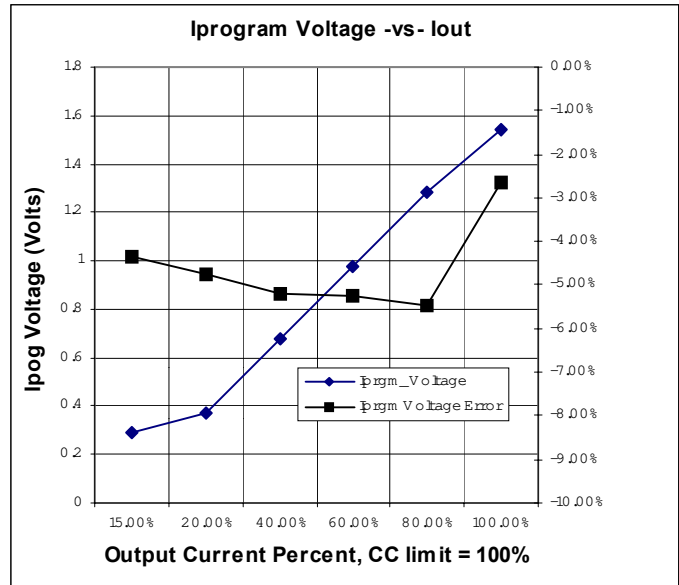
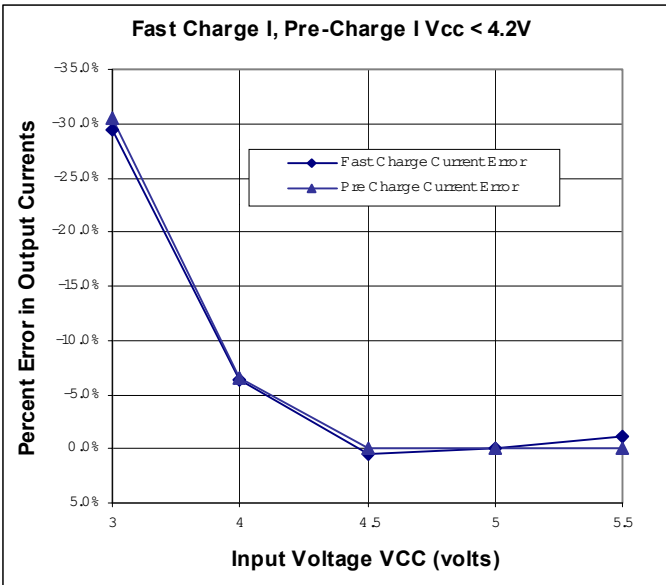

POWER MANAGEMENT

SC806 State Diagram

Under Voltage will force the SC806 into Shutdown Mode from any state.

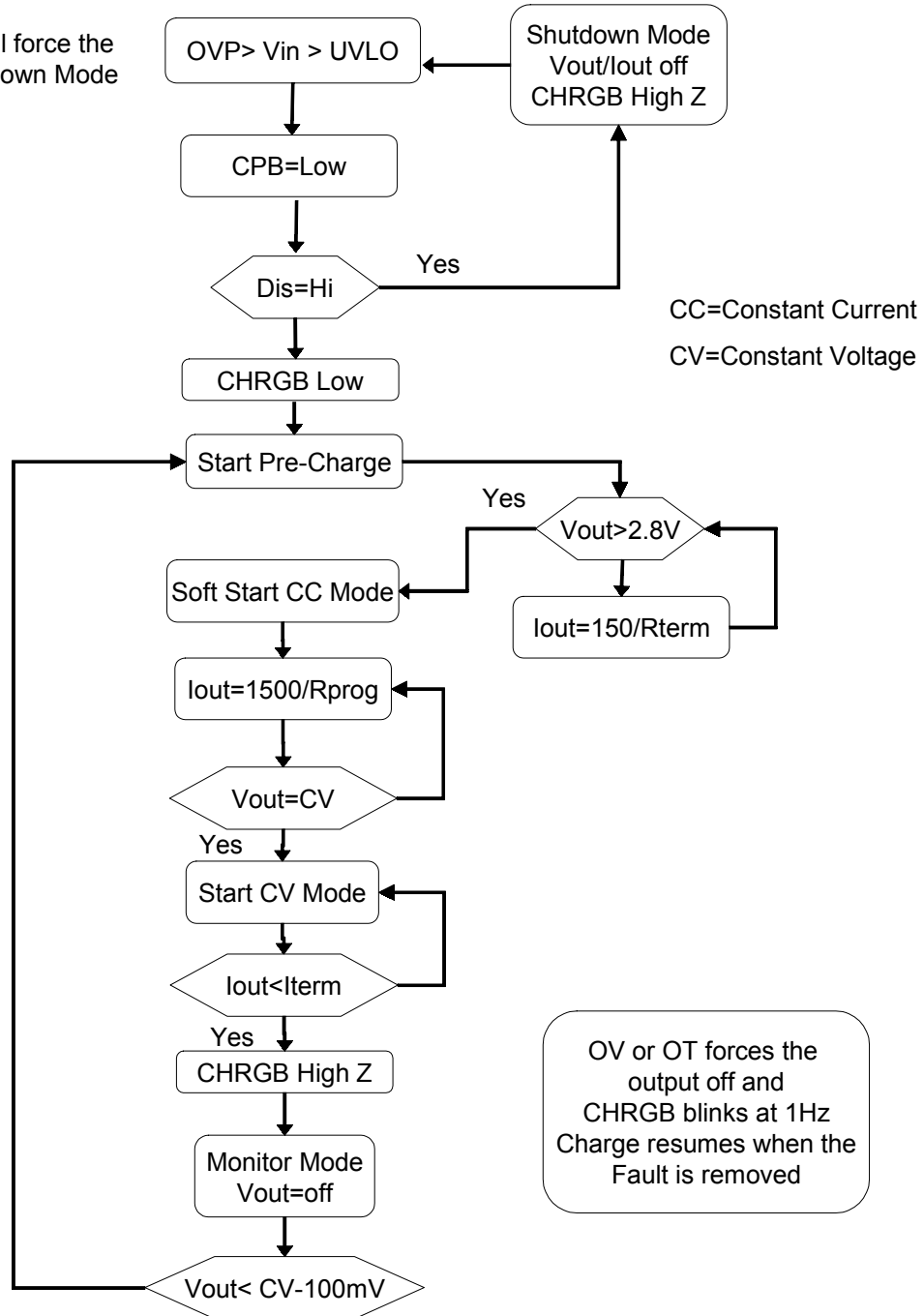

POWER MANAGEMENT

Outline Drawing - MLPD-10, 3 x 3

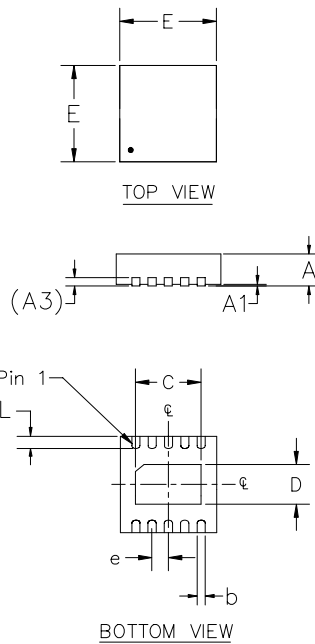

DIM ^N	INCHES		MM		NOTE
	MIN	MAX	MIN	MAX	
A	.032	.039	0.80	1.00	—
A1	0	.002	0	0.05	—
A3	.006	.010	0.15	0.25	REF
b	.008	.011	0.18	0.28	—
C	.076	.083	1.92	2.12	—
D	.044	.052	1.11	1.31	—
E	.118		3.00		NOM
e	.020	BSC	0.50	BSC	—
L	.012	.018	0.30	0.45	—

1 CONTROLLING DIMENSIONS: MILLIMETERS.

Marking Instructions

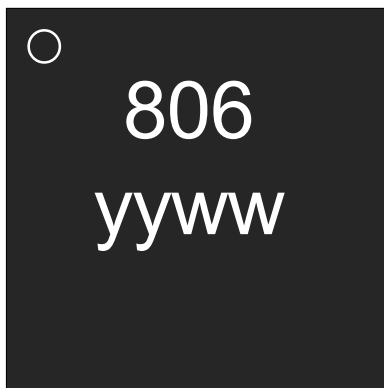

Top View

Marking for the SC806 MLPD-10 Lead package:

yyww = Date Code (Example: 0012)

POWER MANAGEMENT

Land Pattern - MLPD-10, 3 x 3

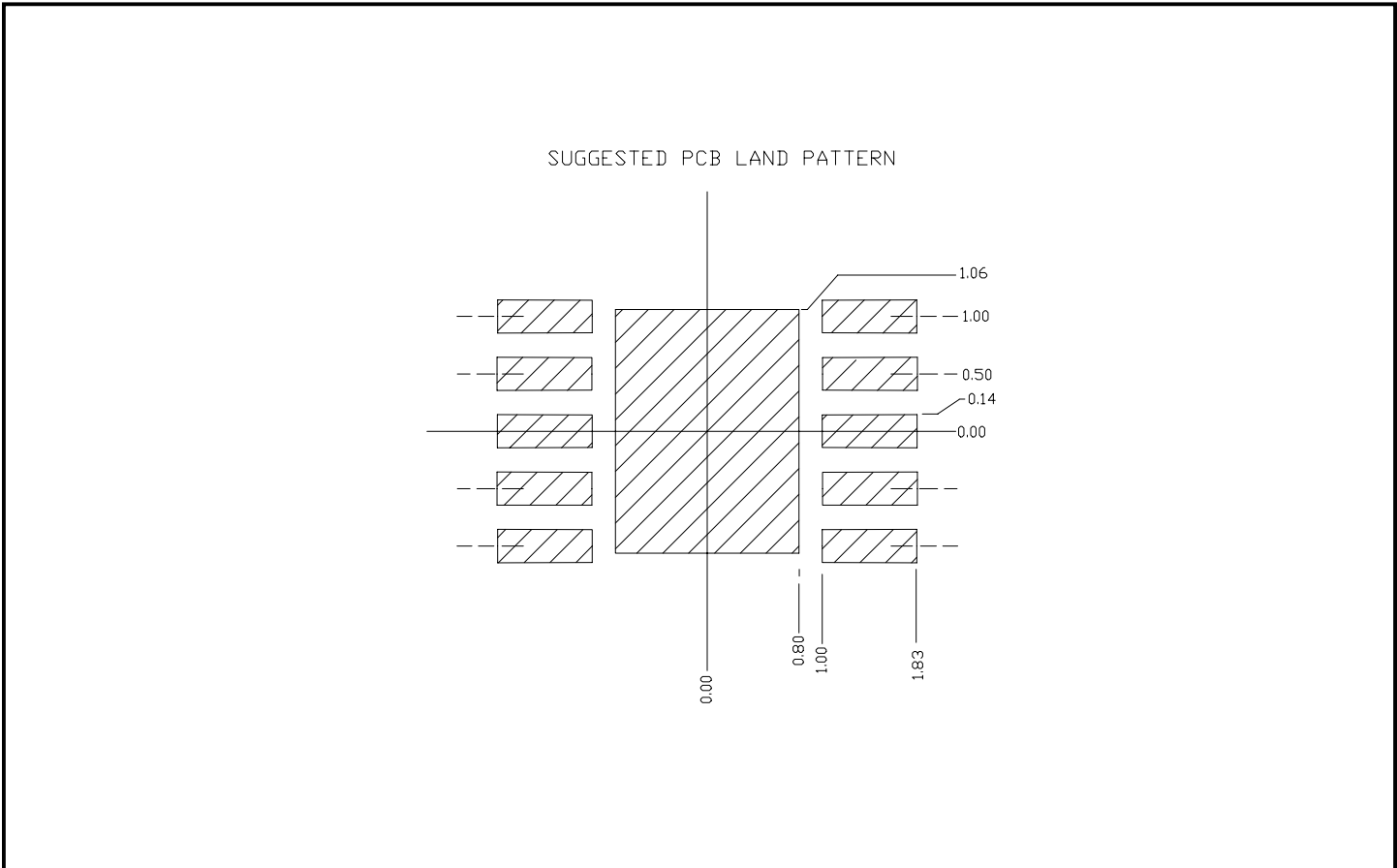

Contact Information

Semtech Corporation
Power Management Products Division
200 Flynn Road, Camarillo, CA 93012
Phone: (805)498-2111 FAX (805)498-3804