



Chipsmall Limited consists of a professional team with an average of over 10 year of expertise in the distribution of electronic components. Based in Hongkong, we have already established firm and mutual-benefit business relationships with customers from,Europe,America and south Asia,supplying obsolete and hard-to-find components to meet their specific needs.

With the principle of “Quality Parts,Customers Priority,Honest Operation,and Considerate Service”,our business mainly focus on the distribution of electronic components. Line cards we deal with include Microchip,ALPS,ROHM,Xilinx,Pulse,ON,Everlight and Freescale. Main products comprise IC,Modules,Potentiometer,IC Socket,Relay,Connector.Our parts cover such applications as commercial,industrial, and automotives areas.

We are looking forward to setting up business relationship with you and hope to provide you with the best service and solution. Let us make a better world for our industry!



Contact us

Tel: +86-755-8981 8866 Fax: +86-755-8427 6832

Email & Skype: info@chipsmall.com Web: www.chipsmall.com

Address: A1208, Overseas Decoration Building, #122 Zhenhua RD., Futian, Shenzhen, China



PRODUCT DATASHEET



SCA10H

Doc. No. 1322 Rev. 1

Table of Contents

1	Features and benefits	3
2	Target Applications	3
3	Product code	3
4	Block diagram	3
5	Dimensions, Measurement Direction, Terminal Configurations and Land Pattern	4
5.1	Dimensions	4
5.2	Measurement Direction.....	5
5.3	Terminal Configurations.....	5
5.4	Recommended Land Pattern	7
6	Maximum absolute ratings	7
7	Electrical specification	8
8	Serial port configuration	8
9	Functional specification	8
10	Application schematic	9
11	Communication	9
12	Firmware update	9
13	Reliability	10
14	Storage	10
15	Handling	11
16	Standard PCB Design (Land Pattern and Dimensions)	11
17	Notice for Chip Placer	11
18	Soldering Conditions	11
19	Cleaning	12
20	Potting	12
21	Operational Environment Conditions	12
22	Packaging	13
22.1	Tray	13
22.2	Inner Box	13
22.3	Outer Box	14
23	Note	14
24	Change control	15

1 Features and benefits

- Contactless measurement enables continuous monitoring without disturbing the patient.
- Ultra low noise and narrow noise bandwidth SCA61T 3D MEMS accelerometer and analog signal conditioning.
- Embedded heart and respiration rate signal processing with 1 Hz output rate.
- Low power and only tens of bytes per second communication bandwidth requirement.
- Easy to use
 - UART-interface
 - Solderable PCB-module

2 Target Applications

- Hospitals, elderly care, assisted living
- Heart and respiration rate detection
- Cardiac output estimation
- Bed occupancy
- Stress and relaxation index
- Sleep quality monitoring

3 Product code

Product code	Quantity	SW version
SCA10H-D01-Sample	1	1
SCA10H-D01-112	112	1

4 Block diagram

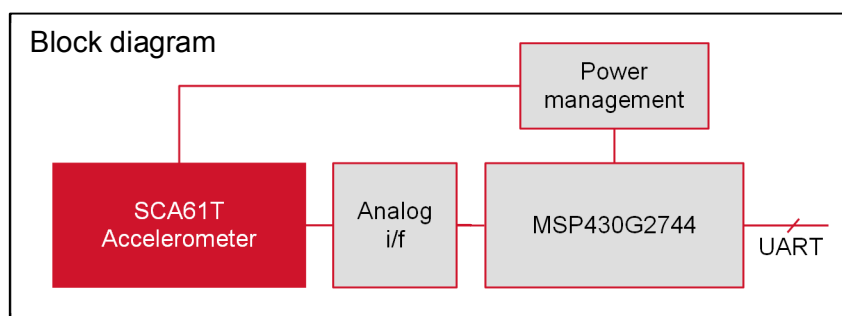

Figure 1 Functional block diagram

5 Dimensions, Measurement Direction, Terminal Configurations and Land Pattern

5.1 Dimensions

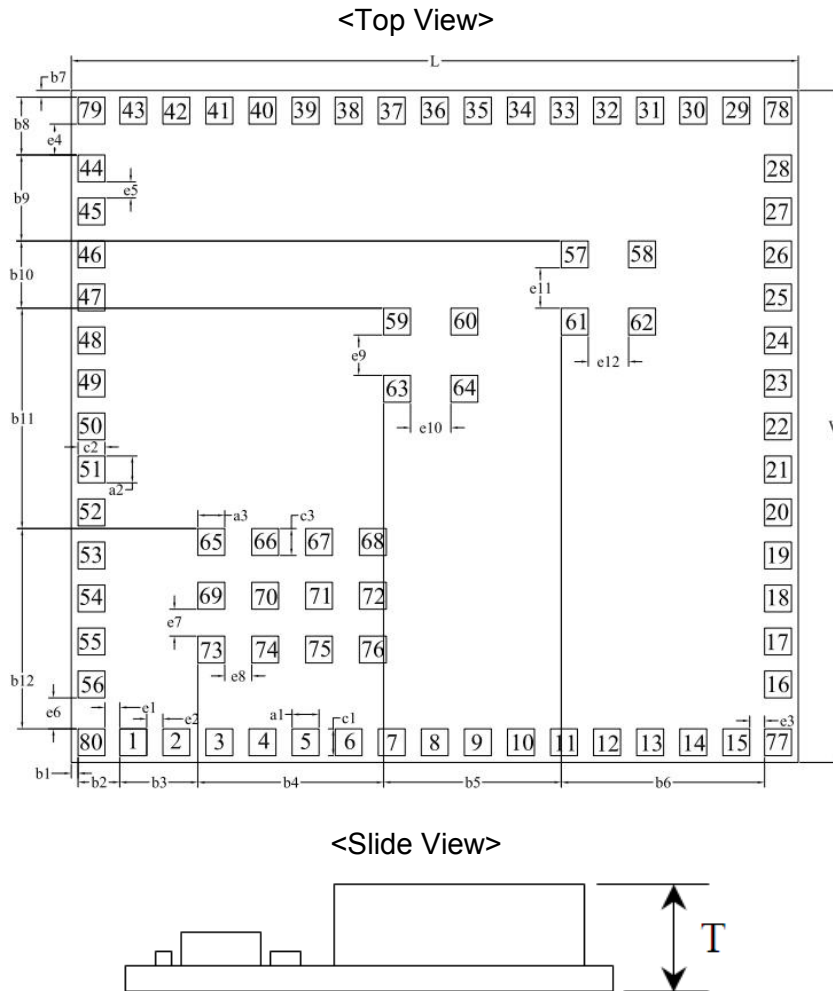

Figure 2 Module dimensions

Table 1 Dimensions (unit: mm)

Mark	Dimension	Mark	Dimension	Mark	Dimension
L	27.6±0.25	W	25.6±0.25	T	6.6max
a1	1.0±0.1	a2	1.0±0.1	a3	1.0±0.1
b1	0.55±0.15	b2	1.55±0.15	b3	2.9±0.15
b4	6.9±0.15	b5	6.6±0.15	b6	7.55±0.15
b7	0.55±0.15	b8	2.15±0.15	b9	3.2±0.15
b10	2.5±0.15	b11	8.2±0.15	b12	7.45±0.15
c1	1.0±0.1	c2	1.0±0.1	c3	1.0±0.1
e1	0.55±0.1	e2	0.6±0.1	e3	0.55±0.1
e4	1.15±0.1	e5	0.6±0.1	e6	1.15±0.1
e7	1.0±0.1	e8	1.0±0.1	e9	1.5±0.1
e10	1.5±0.1	e11	1.5±0.1	e12	1.5±0.1

5.2 Measurement Direction

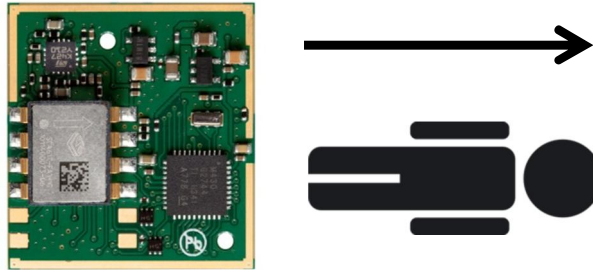

Figure 3 Measurement direction

5.3 Terminal Configurations

Table 2 Pin names and descriptions

Pin no	Name	Description	MSP430G2744 pin ⁽¹⁾
1	P1.2/TA1	P1.2/TA1	P1.2/TA1
2	P1.3/TA2	P1.3/TA2	P1.3/TA2
3	P1.4/SMCLK/TCK	JTAG Interface	P1.4/SMCLK/TCK
4	P1.5/TA0/TMS	JTAG Interface	P1.5/TA0/TMS
5	P1.6/TA1/TDI/TCLK	JTAG Interface	P1.6/TA1/TDI/TCLK
6	P1.7/TA2/TDO/TDI	JTAG Interface	P1.7/TA2/TDO/TDI
7	GND	Ground	
8	GND	Ground	
9	TEST/SBWTCK	TEST/SBWTCK	TEST/SBWTCK
10	JTAG_TCK	NC	
11	INT_IN	Interrupt from host to module	P2.5/ROSC
12	MCU_VDD	NC	DVCC
13	GND	Ground	
14	GND	Ground	
15	GND	Ground	
16	GND	Ground	
17	RST_n/SBWTDIO	Reset	RST/NMI/SBWTDIO
18	VIN	Power Supply voltage	
19	GND	Ground	GND
20	BSL_RX	BSL_RX	P2.2/TA0/A2
21	P3.0/CS_n	SPI Chip Select	P3.0/UCB0STE/UCA0CLK/A5
22	P3.1/SDA/MOSI	I2C data / SPI MOSI	P3.1/UCB0SIMO/UCB0SDA
23	P3.2/SCL/MISO	I2C clk / SPI MISO	P3.2/UCB0SOMI/UCB0SCL
24	P3.3/CLK	SPI CLK	P3.3/UCB0CLK/UCA0STE
25	GND	Ground	
26	GND	Ground	
27	GND	Ground	
28	GND	Ground	
29	GND	Ground	
30	GND	Ground	
31	GND	Ground	
32	GND	Ground	

Pin no	Name	Description	MSP430G2744 pin ⁽¹⁾
33	GND	Ground	
34	SPI_SCK_SCA61T	NC	
35	GND	Ground	
36	SPI_MISO_SCA61T	NC	
37	SPI_MOSI_SCA61T	NC	
38	SPI_MOSI_SCA10X	NC	
39	P4.0/TB0	P4.0/TB0	P4.0/TB0
40	P4.1/TB1	P4.1/TB1	P4.1/TB1
41	P4.2/TB2	P4.2/TB2	P4.2/TB2
42	GND		
43	GND		
44	GND		
45	GND		
46	SPI_CSB_SCA61T	NC	
47	SPI_CSB_SCA10X	NC	
48	ST1	NC	
49	ST2	NC	
50	INT_OUT	Interrupt from module to host	P4.6/TBOUTH/A15
51	UART_TX	UART_TX	P3.4/UCA0TXD/UCA0SIMO
52	UART_RX	UART_RX	P3.5/UCA0RXD/UCA0SOMI
53	XTRA1	NC	P3.6/A6
54	XTRA2	NC	P3.7/A7
55	P1.0	P1.0/TACLK/ADC10CLK	P1.0/TACLK/ADC10CLK
56	BSL_TX	BSL_TX	P1.1/TA0
57~80	GND	Ground	

¹⁾ Please refer to TI's MSP430G2744 datasheet for digital I/O DC and timing parameters. The used processor's supply voltage is 3.3V +/- 5%.

5.4 Recommended Land Pattern

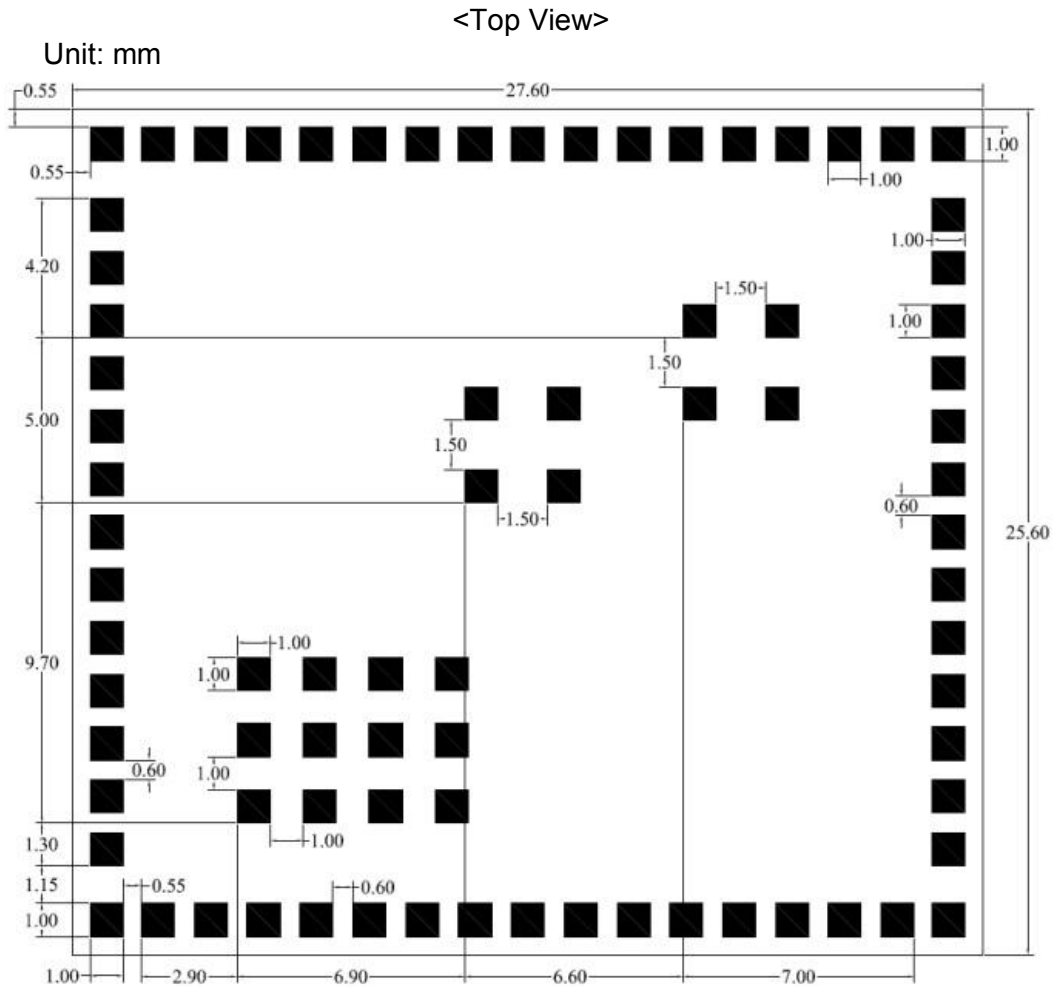

Figure 4 Recommended Land Pattern

Note: The recommended stencil mask thickness for above land pattern is 120µm. The stencil mask area is 0.9mm x 0.9mm, and the position is on the center of each land.

6 Maximum absolute ratings

Table 3 Maximum ratings

Parameter	Min	Max	Unit
Storage temperature	-40	85	°C
Vin	-0.1	20	V
Voltage on any IO-pin, Vin=9 V	-0.1	3.4	V
Voltage on any IO-pin, Vin=0 V	-0.1	0.1	V
ESD (Human Body Model)		3	kV
Mechanical shock ^{**}		1000	g

* When the supply voltage Vin is 9V

** 1 m drop on concrete may cause >> 1000 g shock.

7 Electrical specification

Table 4 Electrical specification parameters

Parameter	Min	Typ	Max	Unit
Module's supply voltage V_{in}	8		10	V
Temperature range	0		80	°C
Current consumption		8		mA
Acceleration raw data noise level ⁽¹⁾		1.3		LSB RMS
Acceleration sensor sensitivity ⁽²⁾		427		LSB/g
Acceleration sensor's step response gain ⁽³⁾	1			

⁽¹⁾ RMS-noise within the application bandwidth measured on stone table in raw data mode without any external vibration or noise.

⁽²⁾ Sensitivity measurement by tilting the module in test mode

⁽³⁾ BCG- and inclination channel gain ratio $G = \text{BCG-channel step response gain} / \text{inclination channel step response gain}$ when sensor's self-test is activated

8 Serial port configuration

Table 5 Serial port configuration

Parameter	
Baud rate	230400 baud
Data bits	8
Parity	None
Stop bits	1
Flow control	None

9 Functional specification

Table 6 Functional specification parameters

Parameter	Min	Typ	Max	Unit
Pulse detection range	40		120	BPM
Steady state pulse rate for test input ⁽¹⁾	48		52	BPM

⁽¹⁾ Accelerometer is disconnected from the circuit. Pre-defined test signal is injected to the output node of the accelerometer V_{out} . With default BCG-parameters steady state output HR is 50 ± 2 BPM. Test setup is according to Figure 5 below and example measurement and simulation is in Figure 6.

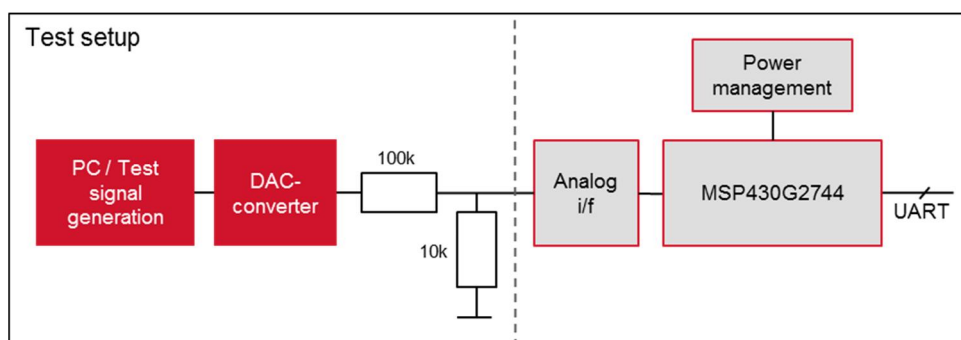

Figure 5 Functional test setup

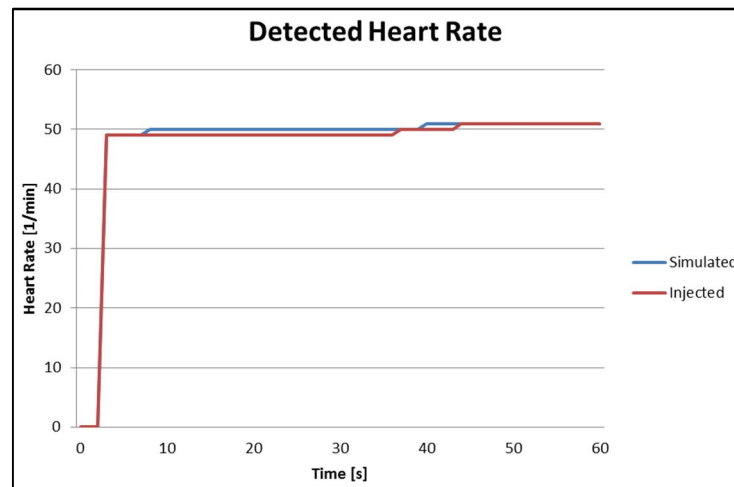
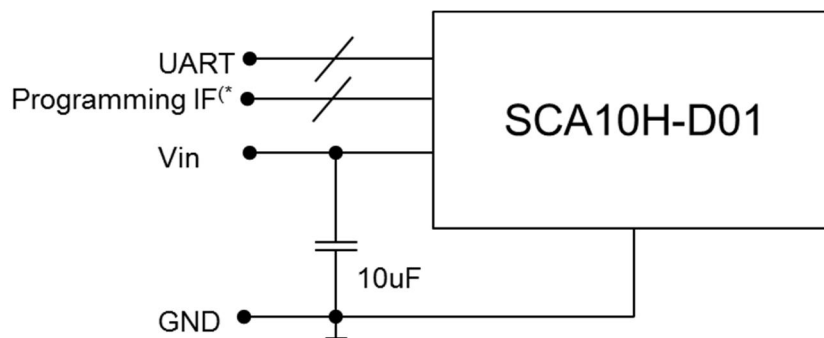

Figure 6 Injected vs simulated output with test signal using default BCG-parameters

10 Application schematic



*) See section firmware update

Figure 7 Application schematic

11 Communication

Communication protocol is discussed in *Product Specification 1327 SCA10H binary protocol specification*.

12 Firmware update

Programming IF includes pins
 #17 RST_n/SBWDIO
 #20 BSL_RX
 #56 BSL_TX
 GND

With FW version 1.5.0.1 and later, modules FW can be updated according to the *Product Specification 1326 SCA10H FW upgrade specification*.

13 Reliability

SCA10H-D01 has been verified against the following test conditions:

Table 7 Test items and conditions

Test item	Test condition
1. Temperature humidity bake (THB)	- 85RH/85°C - 9V biased - 500h - N=12
2. Low temperature storage life (LTSL)	- -40°C - 500 h - N=12
3. Temperature cycling test (TCY)	- -40°C...+85°C - 30 min dwell time - 200 cycles (c) - N=12
4. Mixed gas test	- IEC60068-2-60 method 2 - 14 days - N=5
5. Vibration test	- 10<f<2000Hz, log sweep, A=20 G - 10 cycles/1 ax, 15min/cycle - 2.5hrs/axis, total 7.5hrs
6. Drop test	- 2 directional drops on each 6 sides (=12 drops) on concrete - Module attached to a jig - Drop height 1 m - N=6
7. ESD (HBM)	- 3 kV - N=5
8. ESD (MM)	- 200 V - N=5
9. ESD (CDM)	- 600 V - N=5

14 Storage

Please use this product within 6 months after receipt.

- The product shall be stored without opening the packing under the ambient temperature from 5 to 35 °C and humidity from 20 to 70 %RH. (Packing materials, in particular, may be deformed at the temperature over 40 °C)
- The product shall be stored in non-corrosive gas (Cl₂, NH₃, SO₂, NO_x, etc.).
- Any excess mechanical shock including, but not limited to, sticking the packing materials by sharp object and dropping the product, shall not be applied in order not to damage the packing materials.

This product is applicable to MSL3 (Based on JEDEC Standard J-STD-020)

- After the packing opened, the product shall be stored at <30deg.C / <60%RH and the product shall be used within 168hours.
- When the color of the indicator in the packing changed, the product shall be baked before soldering.
- Baking condition : 125 +5/-0deg.C, 24hours, 1time

The products shall be baked on the heat-resistant tray because the material (Base Tape, Reel Tape and Cover Tape) are not heat-resistant.

15 Handling

Be careful in handling or transporting products because excessive stress or mechanical shock may break products due to the nature of PWB structure.

Handle with care. If products have cracks or damages on their terminals, the characteristics of products may change.

Ensure cleanliness when handling. Pad contamination may affect solderability.

16 Standard PCB Design (Land Pattern and Dimensions)

All the ground terminals should be connected to the ground patterns. Furthermore, the ground pattern should be provided between IN and OUT terminals. Please refer to the specifications for the standard land dimensions.

The recommended land pattern and dimensions is as Murata's standard. The characteristics of products may vary depending on the pattern drawing method, grounding method, land dimensions, land forming method of the NC terminals and the PCB material and thickness. Therefore, be sure to verify the characteristics in the actual set. When using non-standard land pattern, please contact Murata beforehand.

17 Notice for Chip Placer

When placing products on the PCB, products may be stressed and broken by uneven forces from a worn-out chucking locating claw or a suction nozzle. To prevent products from damages, be sure to follow the specifications for the maintenance of the chip placer being used. For the positioning of products on the PCB, be aware that mechanical chucking may damage products.

18 Soldering Conditions

Carefully perform preheating so that the temperature difference (ΔT) between the solder and products surface should be in the following range. When products are immersed in solvent after mounting, pay special attention to maintain the temperature difference within 100 °C.

Soldering must be carried out by the above mentioned conditions to prevent products from damage. Contact Murata before use if concerning other soldering conditions.

Table 8 Soldering methods

Soldering Method	Temperature
Soldering iron method	$\Delta T < 130 \text{ }^\circ\text{C/s}$
Reflow method	

– Soldering iron method conditions are indicated below.

Table 9 Soldering iron conditions

Soldering iron conditions	
Soldering iron power	≤ 18W
Temperature of iron tip	≤ 350 °C
Iron contact time	within 3s

- Diameter of iron-tip: max 3.0 mm.
- Do not allow the iron-tip to directly touch the ceramic element.

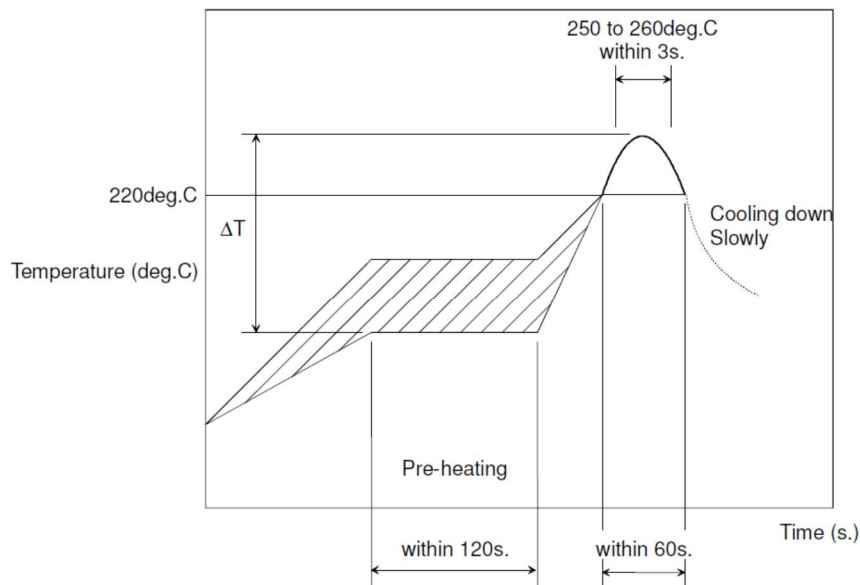

Figure 8 Example reflow soldering standard conditions

19 Cleaning

Any cleaning of this product is not permitted.

20 Potting

Potting the product is not recommended. Potting material may get between the sensor and circuit board resulting in mechanical damages due to thermal expansion.

21 Operational Environment Conditions

Products are designed to work for electronic products under normal environmental conditions (ambient temperature, humidity and pressure). Therefore, products have no problems to be used under the similar conditions to the above-mentioned. However, if products are used under the following circumstances, it may damage products and leakage of electricity and abnormal temperature may occur.

- In an atmosphere containing corrosive gas (Cl₂, NH₃, SO_x, NO_x etc.)
- In an atmosphere containing combustible and volatile gases
- Dusty place
- Direct sunlight place
- Water splashing place

- Humid place where water condenses
- Freezing place

If there are possibilities for products to be used under the preceding clause, consult with Murata before actual use.

As it might be a cause of degradation or destruction to apply static electricity to products, do not apply static electricity or excessive voltage while assembling and measuring.

22 Packaging

22.1 Tray

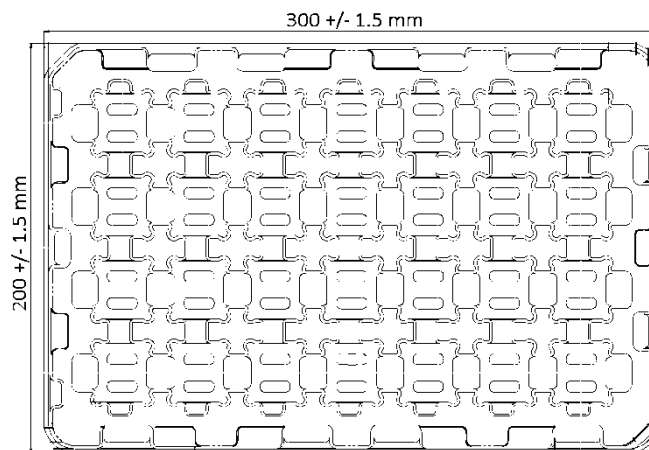

Figure 9 Product tray 28 pcs

22.2 Inner Box

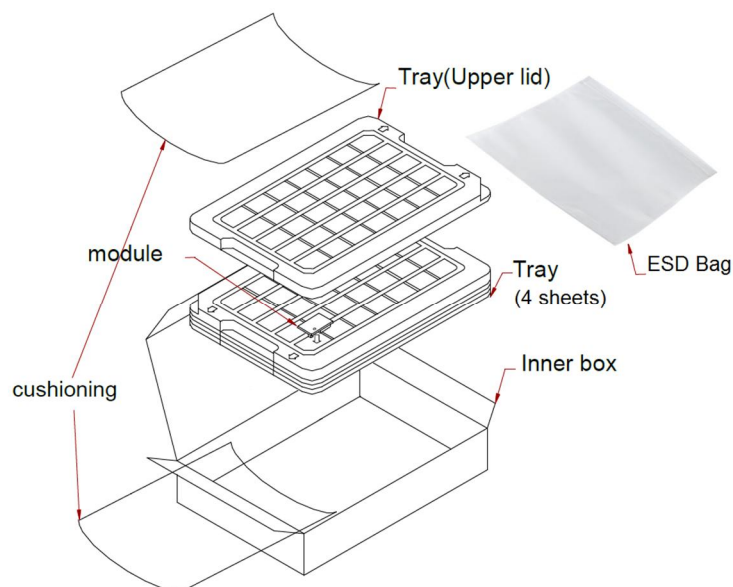

Figure 10 Inner box 112 pcs

22.3 Outer Box

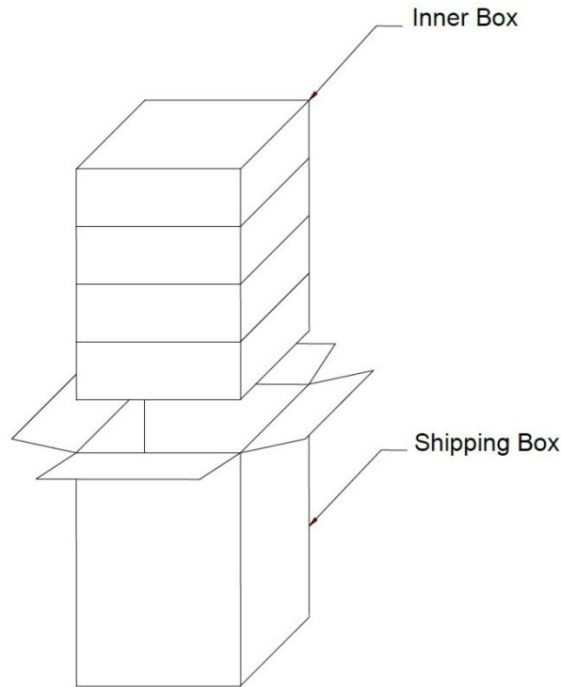

Figure 11 Outer box 448 pcs

- Outer box contains 4 inner boxes. One or more inner boxes can be dummies depending on the actual delivery quantity.
- Please don't stack more than 5 shipping boxes.

23 Note

Please make sure that our product SCA10H has been evaluated and confirmed against your specifications. Please also note that our product SCA10H has not been qualified for medical or similar use where it might directly or indirectly cause damage to the third party's life, body or property.

All the items and parameters in this product specification have been prescribed on the premise that our product is used for the purpose, under the condition and in the environment agreed upon between you and us. You are requested not to use our product deviating from such agreement.

We consider it is not appropriate to include other terms and conditions for transaction warranty in your product specifications, drawings or other technical documents. Therefore, even if your original part of this product specification includes such terms and conditions as warranty clause, product liability clause, or intellectual property infringement liability clause, we are not able to accept such terms and conditions in our product specification unless they are based on the governmental regulation and we have agreed in a separate contract. We would like you to discuss them when negotiating the contract.

24 Change control

Rev.	Date	Change Description
1	09-Sep-15	Document moved to new control system and template, section 8 added, document references in section 11 and 12 updated.