



Chipsmall Limited consists of a professional team with an average of over 10 year of expertise in the distribution of electronic components. Based in Hongkong, we have already established firm and mutual-benefit business relationships with customers from,Europe,America and south Asia,supplying obsolete and hard-to-find components to meet their specific needs.

With the principle of "Quality Parts,Customers Priority,Honest Operation,and Considerate Service",our business mainly focus on the distribution of electronic components. Line cards we deal with include Microchip,ALPS,ROHM,Xilinx,Pulse,ON,Everlight and Freescale. Main products comprise IC,Modules,Potentiometer,IC Socket,Relay,Connector.Our parts cover such applications as commercial,industrial, and automotives areas.

We are looking forward to setting up business relationship with you and hope to provide you with the best service and solution. Let us make a better world for our industry!



## Contact us

Tel: +86-755-8981 8866 Fax: +86-755-8427 6832

Email & Skype: info@chipsmall.com Web: www.chipsmall.com

Address: A1208, Overseas Decoration Building, #122 Zhenhua RD., Futian, Shenzhen, China



## Data Sheet



# SCA2110-D04 2-AXIS HIGH PERFORMANCE ACCELEROMETER WITH DIGITAL SPI INTERFACE

### Features

- 3.3V supply voltage
- $\pm 2$  g measurement range
- 2-axis measurement XZ directions
- $\pm 30$ mg offset accuracy over temp range
- SPI digital interface
- Enhanced self diagnostics features
- Size 7.6 x 3.3 x 8.6 mm (w x h x l)
- Qualified according to AEC-Q100 standard
- Package, pin-out and SPI protocol compatible with Murata digital accelerometer product family
- RoHS compliant Dual Flat Lead (DFL) plastic package suitable for lead free soldering process and SMD mounting
- Proven capacitive 3D-MEMS technology

### Applications

SCA2110-D04 is targeted to automotive applications with high stability requirements. Typical applications include

- Electronic Stability Control (ESC)
- Hill Start Aid (HSA)
- Electronic Parking Brake (EPB)
- Roll Over
- Suspension
- Inclination
- Industrial applications

### General Description

SCA2110-D04 is a high performance two axis accelerometer component based on Murata capacitive 3D-MEMS technology. The component integrates high accuracy micromechanical acceleration sensing together with a flexible SPI digital interface. Dual Flat Lead (DFL) housing of the component guarantees robust operation over the product lifetime.

SCA2110-D04 is designed, manufactured and tested for high stability, reliability and quality requirements of automotive applications. The accelerometer has extremely stable output over wide range of temperature, humidity and mechanical noise. The component is qualified against AEC-Q100 standard and has several advanced self diagnostics features. The DFL housing is suitable for SMD mounting and the component is compatible with RoHS and ELV directives.

SCA2110-D04 is a part of Murata digital accelerometer family and fully compatible with single axis accelerometers (SCA800 series) and other multi axis accelerometers (SCA2100 series and SCA3100 series).

## Performance Characteristics

Vdd=3.3 V and ambient temperature unless otherwise specified.

Parameter	Condition				Units
		Min	Typ	Max	
Analog and digital Vdd		3.0		3.6	V
Current consumption	Active mode		3	5	mA
	Power down mode		0.12		mA
Measurement range	Measurement axes (XZ)	-2		2	g
Operating temperature		-40		125	°C
Offset total error <sup>A)</sup>	Temperature range -40 ... +125 °C	-100		100	mg
	Temperature range -40 ... +105 °C	-70		70	mg
	RT 25 °C ±5°C	-40		40	mg
Offset temperature drift <sup>B)</sup>	Temperature range -40 ... +125 °C	-50		50	mg
	Temperature range -40 ... +105 °C	-30		30	mg
Sensitivity	12 bit output		900		Count/g
Total sensitivity error		-4		4	% FS
Linearity error	+1g ... -1g range	-20		20	mg
Cross-Axis sensitivity				±3.5	%
Zero acceleration output	2-complement		0		Counts
Amplitude response <sup>C)</sup>	-3dB frequency	30		55	Hz
Noise				5	mg RMS
Power on setup time				0.1	s
Output data rate			2000		Hz
Output load				50	pF
SPI clock rate				8	MHz
ESD protection	Human Body Model			2	kV
	Charge Device Model			1	kV
Moisture sensitivity level	IPC/JEDEC J-STD-020C, Level 3				
Mechanical shock				20 000	g

A) Includes offset deviation from 0g value including calibration error and drift over lifetime, temperature and supply voltage.

B) Offset drift due to temperature. Value is a relative value and has not to be centered to zero.

C) See figure 4.

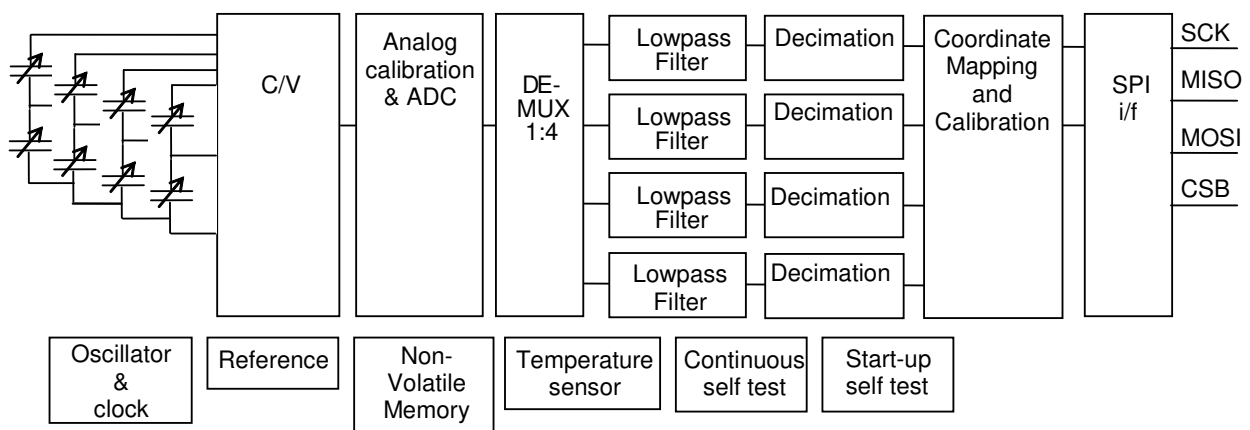

Figure 1. SCA2110-D04 Block diagram

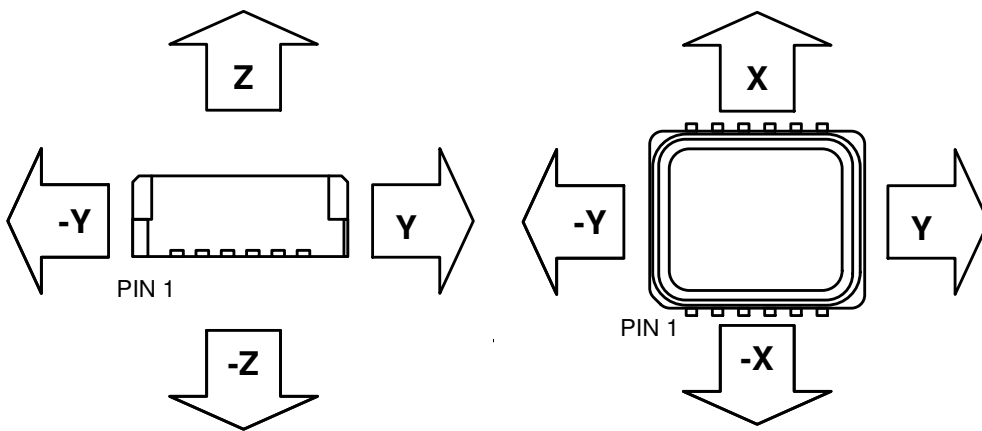

Figure 2. Accelerometer measuring directions

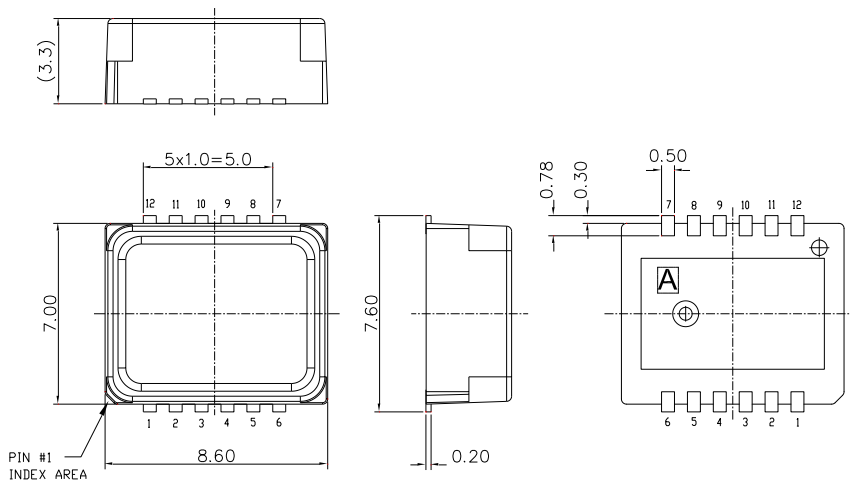

Figure 3. Housing dimensions

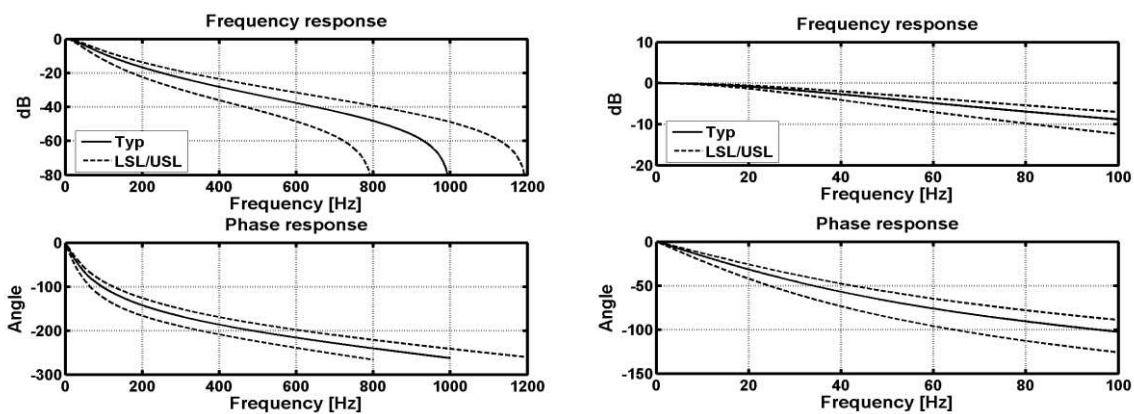

Figure 4. Frequency response curves