



Chipsmall Limited consists of a professional team with an average of over 10 year of expertise in the distribution of electronic components. Based in Hongkong, we have already established firm and mutual-benefit business relationships with customers from,Europe,America and south Asia,supplying obsolete and hard-to-find components to meet their specific needs.

With the principle of "Quality Parts,Customers Priority,Honest Operation,and Considerate Service",our business mainly focus on the distribution of electronic components. Line cards we deal with include Microchip,ALPS,ROHM,Xilinx,Pulse,ON,Everlight and Freescale. Main products comprise IC,Modules,Potentiometer,IC Socket,Relay,Connector.Our parts cover such applications as commercial,industrial, and automotives areas.

We are looking forward to setting up business relationship with you and hope to provide you with the best service and solution. Let us make a better world for our industry!



Contact us

Tel: +86-755-8981 8866 Fax: +86-755-8427 6832

Email & Skype: info@chipsmall.com Web: www.chipsmall.com

Address: A1208, Overseas Decoration Building, #122 Zhenhua RD., Futian, Shenzhen, China



SCR9L

Universal Lamp Alarm Relay



Description

The SCR9L is a universal lamp alarm relay designed to sense the failure of flashing or steady LED beacon lamps or obstruction lamps. The SCR9L energizes when one or more lamps fail. It will monitor the operation of one to eight beacon or obstruction lamps. All monitored lamps must be the same wattage and voltage. When connected to a site monitoring system, it provides the remote lamp monitoring protection required by the FAA-AC No: 150/5345-43E.

Operation

When a lamp fails, the SCR9L senses a decrease in current flow. After a 10s trip delay, the onboard LED glows and the two alarm outputs energize. The outputs and the LED are reset when the failed lamps are replaced and the unit is recalibrated. The SCR9L will sense an open flasher, it will not sense a continuously ON flasher (see FB Series). Removing input voltage de-energizes the output and the LED's. It does not change the calibration.

Wiring Diagram

BEACON LAMP CONNECTION DIAGRAM

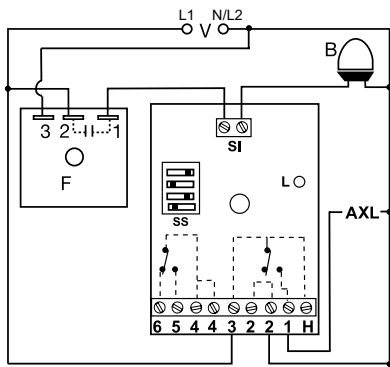

- V = Voltage
- B = Beacon Lamps
- SS = Selector Switch
- L = LED Indicator
- F = Flasher
- AXL = Auxiliary Load/Alarm
- OL = Obstruction Lamps
- SI = Sensor Input
- H = "3" Spare AC Hot Connection (2A max.)

OBSTRUCTION LAMP CONNECTION DIAGRAM

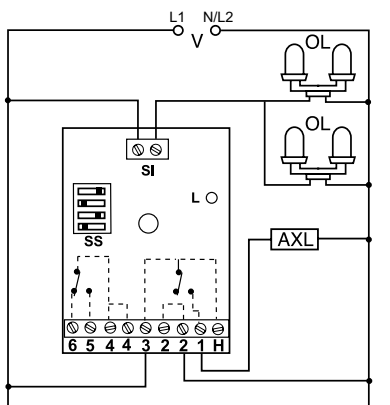

Features & Benefits

FEATURES	BENEFITS
Self calibrating	Designed for use with all types of LED beacon and obstruction lamps
Failsafe beacon monitoring	Relay will also provide an alarm signal on a failed flasher (open)
Number of lamps monitored is switch selectable up to 8	User selection allows quick set up and easy adaption to multiple applications
Universal voltage 120 to 230VAC	Designed for use in most applications
Isolated, 10A, SPDT alarm output contacts	Provides remote beacon monitoring when connected to a site monitoring system, as is required by the FAA
LED indication	Provides visual relay status of operation, alarm, trip delay, and calibration
Fully encapsulated	Protects against shock, vibration, and humidity

Accessories

C103PM (AL) DIN Rail
35 mm aluminum DIN rail available in a 36 in. (91.4 cm) length.

P1023-20 DIN Rail Adapter
Allows module to be mounted on a 35 mm DIN type rail with two #10 screws.

SCR9L



Calibration

Alarm relays must be calibrated at initial installation and when LED lamps are replaced. Due to LED lamp aging, recalibration is recommended every 12 months.

1. Remove input voltage
2. Move calibration switch to off position
3. Re-apply input voltage
4. LED will flash red to indicate the unit is ready for calibration
5. Visually inspect structure's lighting to make sure all lamps and flashers (if used) are operating properly
6. Remove input voltage
7. Adjust lamp selector switches for the correct number of lamps to be monitored (see adjustment diagram below)
8. Re-apply input voltage
9. LED should flash red
10. Move calibrate switch to ON position
11. The LED will alternate flashing red and green
12. LED will glow steady green within 30 secs.
Calibration is complete

Calibration Failed

If the LED double blinks red, calibration failed. Remove input voltage and repeat steps 6-8.

Notes:

- a. Monitoring a mixture of LED beacons and LED obstruction lamps is not possible with the SCR9L.
- b. This alarm relay is not designed to monitor incandescent lamps.
- c. Applying input voltage when the calibrate switch is in the OFF position, erases the previous calibration settings. The LED will flash Red. The output relays are OFF and the unit will not sense lamp failures.
- d. Only one temperature compensated LED beacon can be monitored with this product. A combination of temperature compensated and standard LED beacons cannot be monitored.

Adjustment Example

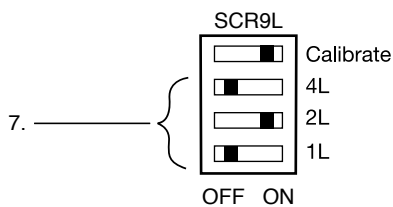

Example Shown: SCR9L two lamps are ON during normal operation.

Indicator Table

L	Green	Input ON & Calibrated
L	Green Flashing	Trip Delay
L	Red	Lamp Failure
L	Red/Green Flashing	Calibrating
L	Red Flashing	Not Calibrated

Specifications

Sensors

Calibration Range

(total all Lamps) 150mA - 8.0A

Absolute Max Current

(total all Lamps) 15A max. (may not calibrate above 8A)

Single Lamp Current

150mA - 8.0A (total all lamps < 8.0A)

Time Delay

Trip Delay

Input

Input Voltage/Tolerance

AC Line Frequency

Output

Line Voltage Output (SPNO)

Isolated Alarm Output (SPDT)

Auxiliary Input Voltage (H)

Mechanical

Mounting

Dimensions

Termination

Protection

Circuitry

Environmental

Operating / Storage

Temperature

Weight

Operating / Storage

Temperature

Weight

Weight

Weight

Weight

Weight

Weight

Weight

Weight

Weight

Weight

Weight

Weight

Weight

Weight

Weight

Weight

Weight

Weight

Weight

Weight

150mA - 8.0A

15A max. (may not calibrate above 8A)

150mA - 8.0A (total all lamps < 8.0A)

Factory fixed \approx 10s

120 to 230VAC \pm 15%

50/60Hz

To operate a spare lamp or alarm

5A @ 240VAC or 30VDC resistive;

1/4 hp @ 125VAC; 1/2 hp @ 250VAC

10A @ 240VAC or 30VDC resistive;

1/4 hp @ 125VAC; 1/2 hp @ 250VAC

\leq 2A @ 230VAC

One #10 (M5 x 0.8) screw

H 76.7 mm (3"); **W** 51.3 mm (2.02");

D 41.7 mm (1.64")

IP20 screw terminals for up to 14 AWG

(2.45 mm²) wire or two 16 AWG

(1.3 mm²) wires

Encapsulated

-40° to 60°C / - 40° to 85°C

\approx 3.9 oz (111 g)