



Chipsmall Limited consists of a professional team with an average of over 10 year of expertise in the distribution of electronic components. Based in Hongkong, we have already established firm and mutual-benefit business relationships with customers from,Europe,America and south Asia,supplying obsolete and hard-to-find components to meet their specific needs.

With the principle of "Quality Parts,Customers Priority,Honest Operation,and Considerate Service",our business mainly focus on the distribution of electronic components. Line cards we deal with include Microchip,ALPS,ROHM,Xilinx,Pulse,ON,Everlight and Freescale. Main products comprise IC,Modules,Potentiometer,IC Socket,Relay,Connector.Our parts cover such applications as commercial,industrial, and automotives areas.

We are looking forward to setting up business relationship with you and hope to provide you with the best service and solution. Let us make a better world for our industry!



## Contact us

Tel: +86-755-8981 8866 Fax: +86-755-8427 6832

Email & Skype: info@chipsmall.com Web: www.chipsmall.com

Address: A1208, Overseas Decoration Building, #122 Zhenhua RD., Futian, Shenzhen, China



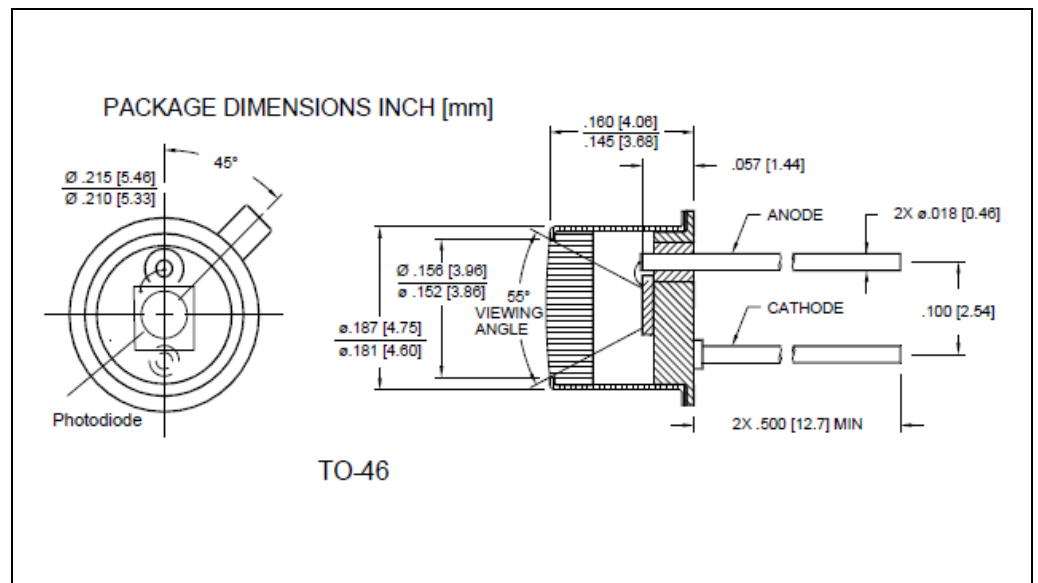

### DESCRIPTION

The **SD012-UVA-011** is a GaN UVA photodiode with a 0.076 mm<sup>2</sup> active area. Unlike most UV detectors it cuts off unwanted visible light from its detection spectrum (**220-370nm**), thereby eliminating the need for optical filter. Photodiode is assembled in a hermetic TO-46 package

### RELIABILITY

This API high-reliability detector is in principle able to meet military test requirements (Mil-STD-750, Mil-STD-883) after proper screening and group test. Contact API for recommendations on specific test conditions and procedures.

### ABSOLUTE MAXIMUM RATINGS

PARAMETER	MIN	MAX	UNITS
Storage Temperature	-30	+85	°C
Operating Temperature	-40	+125	°C
Soldering Temperature*	-	+240	°C
Forward Current	-	1.0	mA
Reverse Voltage	-	5.0	V

T<sub>a</sub> = 23°C unless noted

### FEATURES

- Schottky-Type Photodiode
- Photovoltaic Mode Operation
- Low Noise
- High Speed
- Visible Blindness

### APPLICATIONS

- UVA Detection and Monitoring
- Medical
- Military

**OPTO-ELECTRICAL PARAMETERS**

T<sub>a</sub> = 23°C unless noted otherwise

PARAMETER	TEST CONDITIONS	MIN	TYP	MAX	UNITS
Dark Current	V <sub>R</sub> = 0.1V	-	0.1	100	pA
Shunt Resistance	V <sub>R</sub> = 10 mV	1.0	100	-	GΩ
Short Circuit Current	UVI=1.0	-	20	-	nA
Spectral Application Range	Spot Scan	220	-	370	nm
Responsivity Peak	λ = 350 nm V, V <sub>R</sub> = 0 V	-	0.18	-	A/W
Capacitance	V <sub>bias</sub> = 0V; f = 1 MHz	-	10	-	pF
Noise Equivalent Power	λ = 350 nm	-	1.6	-	10 <sup>-17</sup> W/Hz <sup>0.5</sup>

**TYPICAL PERFORMANCE**

**UV-A PHOTOCURRENT**

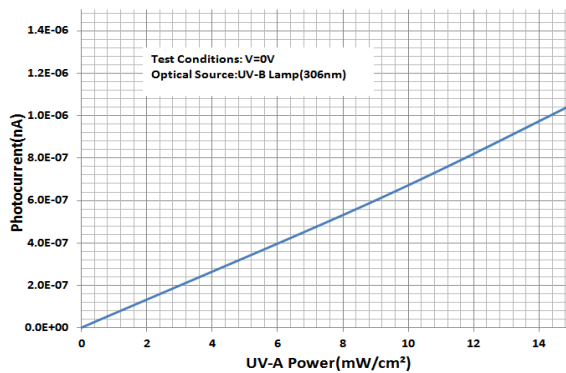

**UV-I PHOTOCURRENT**

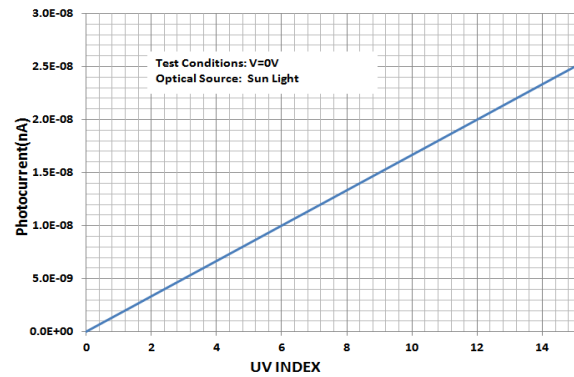

**NOISE vs. BIAS**

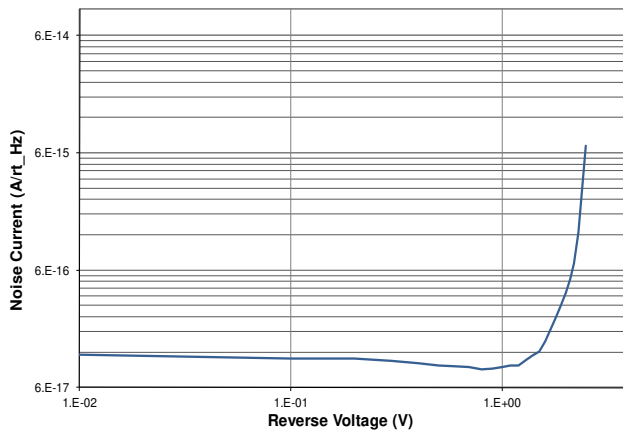

**SPECTRAL RESPONSE**

