



Chipsmall Limited consists of a professional team with an average of over 10 year of expertise in the distribution of electronic components. Based in Hongkong, we have already established firm and mutual-benefit business relationships with customers from,Europe,America and south Asia,supplying obsolete and hard-to-find components to meet their specific needs.

With the principle of “Quality Parts,Customers Priority,Honest Operation,and Considerate Service”,our business mainly focus on the distribution of electronic components. Line cards we deal with include Microchip,ALPS,ROHM,Xilinx,Pulse,ON,Everlight and Freescale. Main products comprise IC,Modules,Potentiometer,IC Socket,Relay,Connector.Our parts cover such applications as commercial,industrial, and automotives areas.

We are looking forward to setting up business relationship with you and hope to provide you with the best service and solution. Let us make a better world for our industry!



## Contact us

Tel: +86-755-8981 8866 Fax: +86-755-8427 6832

Email & Skype: info@chipsmall.com Web: www.chipsmall.com

Address: A1208, Overseas Decoration Building, #122 Zhenhua RD., Futian, Shenzhen, China



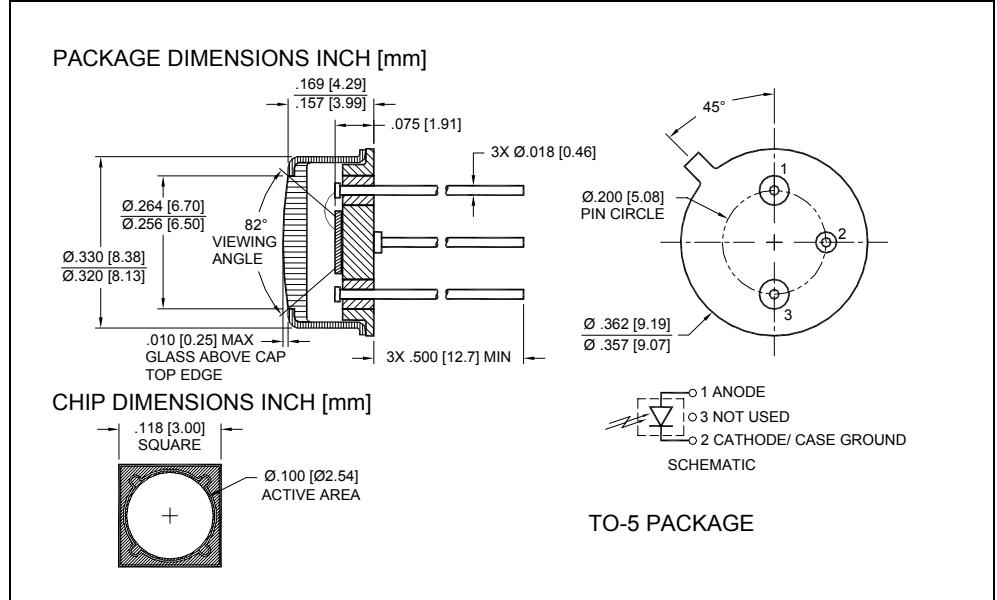

### FEATURES

- Low noise
- Blue enhanced
- High shunt resistance
- High response

### DESCRIPTION

The **SD 100-12-22-021** is a blue enhanced silicon PIN photodiode, packaged in a hermetic TO-5 metal package.

### APPLICATIONS

- Instrumentation
- Industrial
- Medical



### ABSOLUTE MAXIMUM RATING (TA) = 23°C UNLESS OTHERWISE NOTED

SYMBOL	PARAMETER	MIN	MAX	UNITS
$V_{BR}$	Reverse Voltage		75	V
$T_{STG}$	Storage Temperature	-55	+150	°C
$T_O$	Operating Temperature	-40	+125	°C
$T_S$	Soldering Temperature*		+240	°C

\* 1/16 inch from case for 3 seconds max.

### SPECTRAL RESPONSE

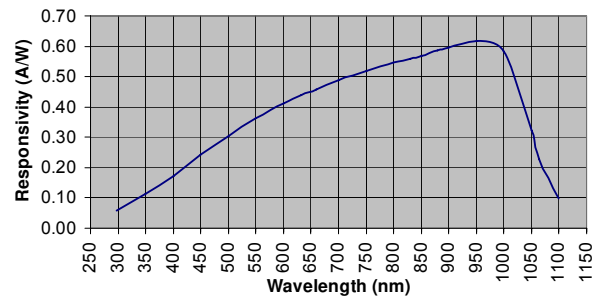

### ELECTRO-OPTICAL CHARACTERISTICS RATING (TA) = 23°C UNLESS OTHERWISE NOTED

SYMBOL	CHARACTERISTIC	TEST CONDITIONS	MIN	TYP	MAX	UNITS
$I_D$	Dark Current	$V_R = 5V$		1.6	6.4	nA
$R_{SH}$	Shunt Resistance	$V_R = 10\text{ mV}$	300			$M\Omega$
$C_J$	Junction Capacitance	$V_R = 0\text{ V}, f = 1\text{ MHz}$		87		pF
		$V_R = 5\text{ V}, f = 1\text{ MHz}$		26		
$\lambda_{range}$	Spectral Application Range	Spot Scan	350		1100	nm
R	Responsivity	$\lambda = 450\text{ nm V}, V_R = 0\text{ V}$	0.20	0.28		A/W
$V_{BR}$	Breakdown Voltage	$I = 10\ \mu A$		50		V
NEP	Noise Equivalent Power	$V_R = 0V @ \lambda = \text{Peak}$		$4.2 \times 10^{-14}$		$W/\sqrt{\text{Hz}}$
$t_r$	Response Time**	$RL = 50\ \Omega, V_R = 0\text{ V}$		190		nS
		$RL = 50\ \Omega, V_R = 10\text{ V}$		13		

\*\*Response time of 10% to 90% is specified at 660nm wavelength light.

Information in this technical datasheet is believed to be correct and reliable. However, no responsibility is assumed for possible inaccuracies or omission. Specifications are subject to change without notice.