



Chipsmall Limited consists of a professional team with an average of over 10 year of expertise in the distribution of electronic components. Based in Hongkong, we have already established firm and mutual-benefit business relationships with customers from,Europe,America and south Asia,supplying obsolete and hard-to-find components to meet their specific needs.

With the principle of "Quality Parts,Customers Priority,Honest Operation,and Considerate Service",our business mainly focus on the distribution of electronic components. Line cards we deal with include Microchip,ALPS,ROHM,Xilinx,Pulse,ON,Everlight and Freescale. Main products comprise IC,Modules,Potentiometer,IC Socket,Relay,Connector.Our parts cover such applications as commercial,industrial, and automotives areas.

We are looking forward to setting up business relationship with you and hope to provide you with the best service and solution. Let us make a better world for our industry!



Contact us

Tel: +86-755-8981 8866 Fax: +86-755-8427 6832

Email & Skype: info@chipsmall.com Web: www.chipsmall.com

Address: A1208, Overseas Decoration Building, #122 Zhenhua RD., Futian, Shenzhen, China



PROTECTION PRODUCTS

Description

The SDxx TVS diodes are designed to replace multilayer varistors (MLVs) in portable applications such as cell phones, notebook computers, and PDA's. They offer superior electrical characteristics such as lower clamping voltage and no device degradation when compared to MLVs. The SDxx series TVS diodes are designed to protect sensitive semiconductor components from damage or upset due to electrostatic discharge (ESD) and other voltage induced transient events.

The SDxx is in a SOD-323 package and will protect one unidirectional line. They are available with working voltages of 5 volts (SD05) and 12 volts (SD12). These devices will fit on the same PCB pad area as an 0805 MLV device. They give the designer the flexibility to protect one line in applications where arrays are not practical. Additionally, it may be "sprinkled" around the board in applications where board space is at a premium.

They may be used to meet the ESD immunity requirements of IEC 61000-4-2, Level 4 ($\pm 15\text{kV}$ air, $\pm 8\text{kV}$ contact discharge).

Features

- ◆ 350 Watts peak pulse power ($t_p = 8/20\mu\text{s}$)
- ◆ Transient protection for data lines to
IEC 61000-4-2 (ESD) $\pm 25\text{kV}$ (air), $\pm 10\text{kV}$ (contact)
IEC 61000-4-4 (EFT) 40A (5/50ns)
IEC 61000-4-5 (Lightning) 24A (8/20 μs)
- ◆ Small package for use in portable electronics
- ◆ Suitable replacement for MLV's in ESD protection applications
- ◆ Protects one I/O or power line
- ◆ Low clamping voltage
- ◆ Working voltages: 5V and 12V
- ◆ Low leakage current
- ◆ Solid-state silicon-avalanche technology

Mechanical Characteristics

- ◆ EIAJ SOD-323 package
- ◆ Molding compound flammability rating: UL 94V-0
- ◆ Marking : Marking code, cathode band
- ◆ Packaging : Tape and Reel per EIA 481

Applications

- ◆ Cell Phone Handsets and Accessories
- ◆ Microprocessor based equipment
- ◆ Personal Digital Assistants (PDA's)
- ◆ Notebooks, Desktops, and Servers
- ◆ Portable Instrumentation
- ◆ Pagers Peripherals

Schematic & PIN Configuration

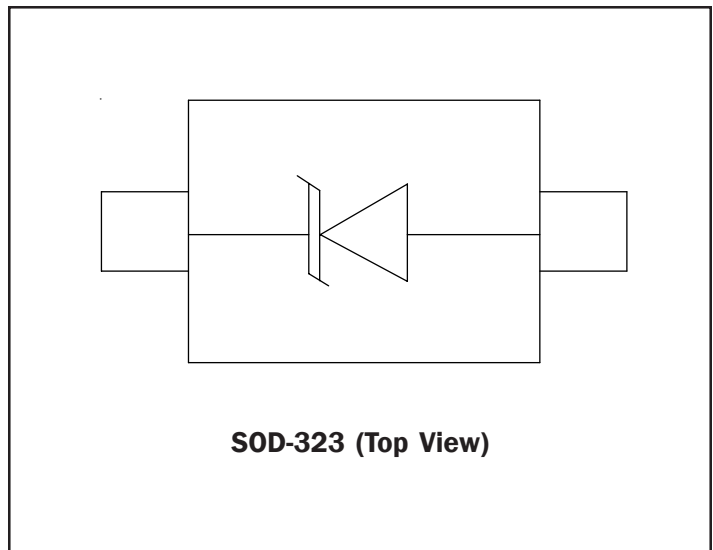

PROTECTION PRODUCTS
Absolute Maximum Rating

Rating	Symbol	Value	Units
Peak Pulse Power ($t_p = 8/20\mu s$)	P_{pk}	350	Watts
ESD Voltage (HBM Waveform per IEC 61000-4-2)	V_{ESD}	30	kV
Lead Soldering Temperature	T_L	260 (10 sec.)	°C
Operating Temperature	T_J	-55 to +125	°C
Storage Temperature	T_{STG}	-55 to +150	°C

Electrical Characteristics

SD05						
Parameter	Symbol	Conditions	Minimum	Typical	Maximum	Units
Reverse Stand-Off Voltage	V_{RWM}				5	V
Reverse Breakdown Voltage	V_{BR}	$I_t = 1mA$	6			V
Reverse Leakage Current	I_R	$V_{RWM} = 5V, T=25^\circ C$			10	μA
Clamping Voltage	V_C	$I_{PP} = 5A, t_p = 8/20\mu s$			9.8	V
Clamping Voltage	V_C	$I_{PP} = 24A, t_p = 8/20\mu s$			14.5	V
Peak Pulse Current	I_{PP}	$t_p = 8/20\mu s$			24	A
Junction Capacitance	C_J	$V_R = 0V, f = 1MHz$			350	pF

SD12						
Parameter	Symbol	Conditions	Minimum	Typical	Maximum	Units
Reverse Stand-Off Voltage	V_{RWM}				12	V
Reverse Breakdown Voltage	V_{BR}	$I_t = 1mA$	13.3			V
Reverse Leakage Current	I_R	$V_{RWM} = 12V, T=25^\circ C$			1	μA
Clamping Voltage	V_C	$I_{PP} = 5A, t_p = 8/20\mu s$			19	V
Clamping Voltage	V_C	$I_{PP} = 15A, t_p = 8/20\mu s$			25	V
Peak Pulse Current	I_{PP}	$t_p = 8/20\mu s$			15	A
Junction Capacitance	C_J	$V_R = 0V, f = 1MHz$			150	pF

PROTECTION PRODUCTS

Typical Characteristics

Non-Repetitive Peak Pulse Power vs. Pulse Time

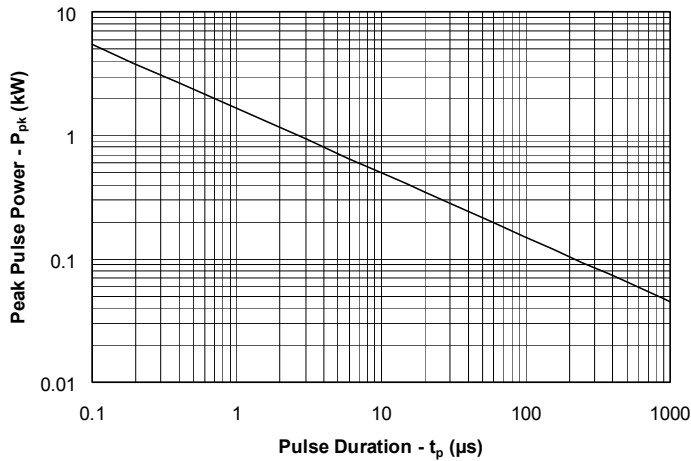

Power Derating Curve

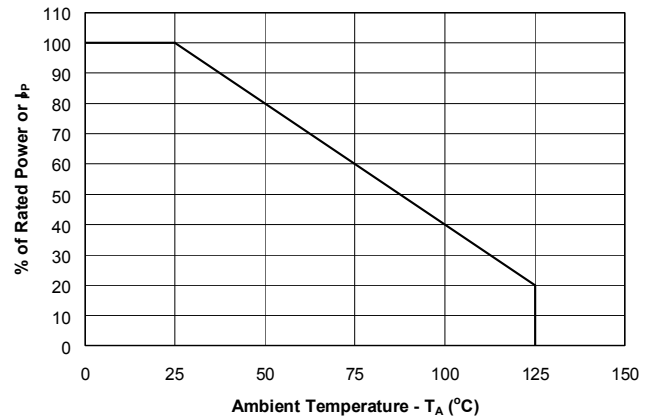

Pulse Waveform

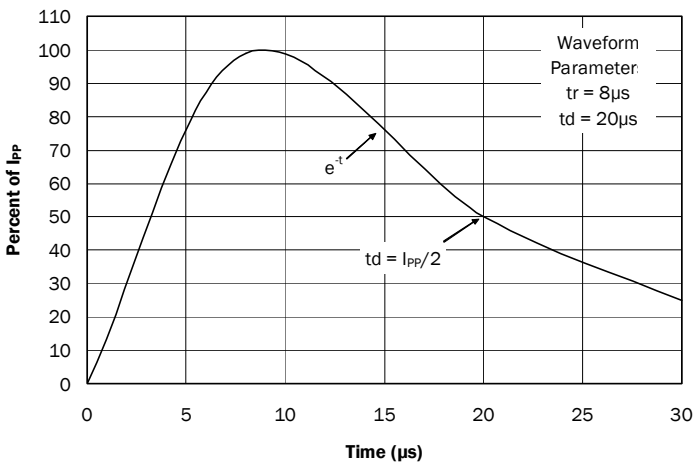

Clamping Voltage vs. Peak Pulse Current

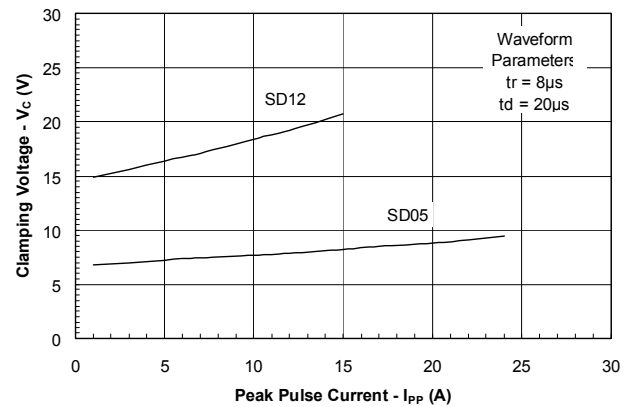

Capacitance vs. Reverse Voltage

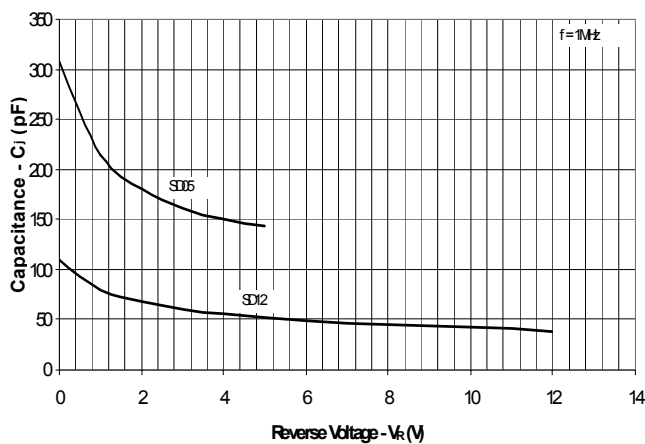

Forward Voltage vs. Forward Current

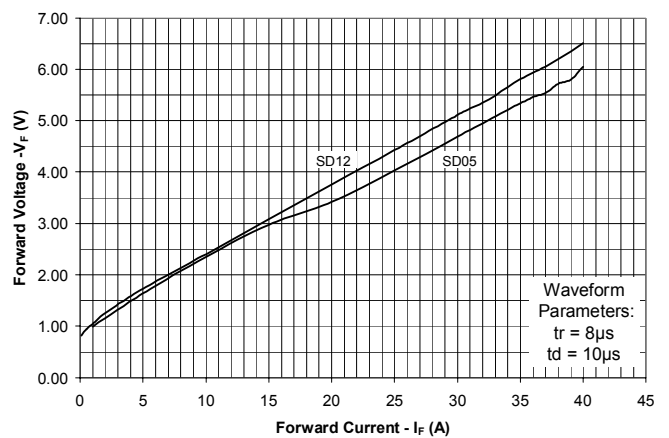

PROTECTION PRODUCTS

Applications Information

Device Connection Options

The SDxx TVS diodes are designed to protect one data, I/O, or power supply line. The device is designed to replace multi-layer varistors (MLVs) in portable applications. It is easily implemented on existing 0805 MLV pads and is only slightly larger than 0603 MLV pads. The device is unidirectional and may be used on lines where the signal polarity is above ground. The cathode band should be placed towards the line that is to be protected.

Circuit Board Layout Recommendations for Suppression of ESD.

Good circuit board layout is critical for the suppression of fast rise-time transients such as ESD. The following guidelines are recommended (Refer to application note SI99-01 for more detailed information):

- Place the TVS near the input terminals or connectors to restrict transient coupling.
- Minimize the path length between the TVS and the protected line.
- The ESD transient return path to ground should be kept as short as possible.
- Place a TVS and decoupling capacitor between power and ground of components that may be vulnerable to electrostatic discharges to the ground plane.
- Minimize all conductive loops including power and ground loops.
- Use multilayer boards when possible.
- Minimize interconnecting line lengths.
- Never run critical signals near board edges.
- Fill unused portions of the PCB with ground plane.

Matte Tin Lead Finish

Matte tin has become the industry standard lead-free replacement for SnPb lead finishes. A matte tin finish is composed of 100% tin solder with large grains. Since the solder volume on the leads is small compared to the solder paste volume that is placed on the land pattern of the PCB, the reflow profile will be determined by the requirements of the solder paste. Therefore, these devices are compatible with both lead-free and SnPb assembly techniques. In addition, unlike other lead-free compositions, matte tin does not have any added alloys that can cause degradation of the solder joint.

Device Schematic and Pin Configuration

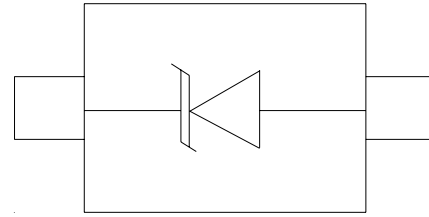

Size Comparison to 0805 MLV

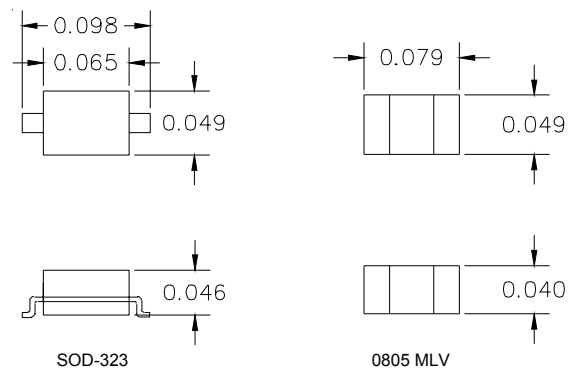

SOD-323

0805 MLV

Note: Nominal dimensions in inches

Component Placement Comparison

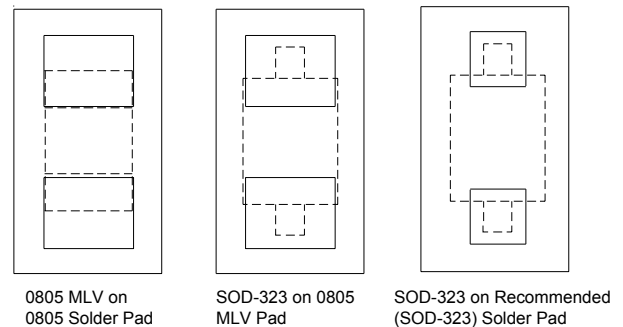

0805 MLV on
0805 Solder Pad

SOD-323 on 0805
MLV Pad

SOD-323 on Recommended
(SOD-323) Solder Pad

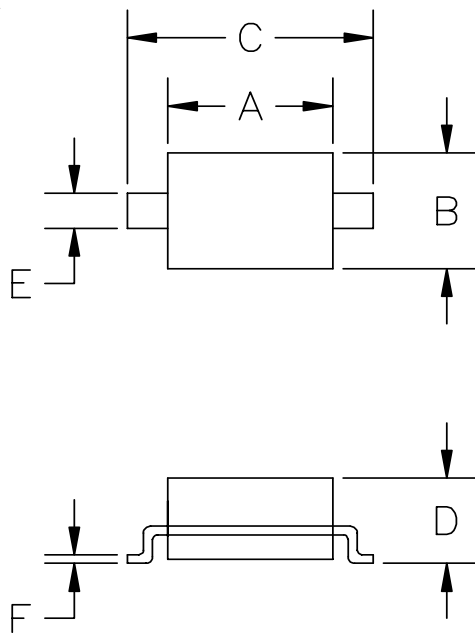
PROTECTION PRODUCTS
Outline Drawing

DIM ^N	INCHES		MM ¹		NOTE
	MIN	MAX	MIN	MAX	
A	.060	.071	1.5	1.8	—
B	.045	.054	1.2	1.4	—
C	.090	.107	2.3	2.7	—
D	—	.043	—	1.1	—
E	.012	.016	0.3	0.4	—
F	.004	.010	.10	.25	—
H	—	.004	—	.10	—

¹ CONTROLLING DIMENSION: MILLIMETERS

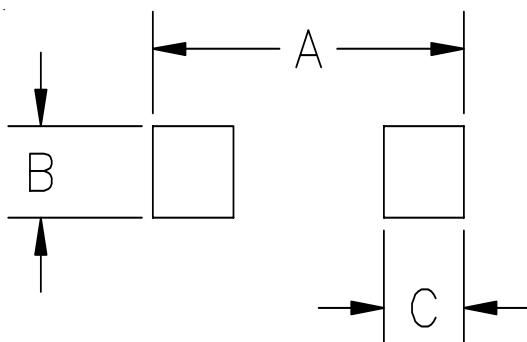
Land Pattern

DIM ^N	INCHES		MM ¹		NOTE
	MIN	MAX	MIN	MAX	
A	—	.120	—	3.05	—
B	—	.031	—	0.8	—
C	—	.031	—	0.8	—

¹ CONTROLLING DIMENSION: MILLIMETERS

PROTECTION PRODUCTS**Marking Codes**

Part Number	Marking Code
SD05	5U
SD12	6U

Ordering Information

Part Number	Lead Finish	Qty per Reel	Reel Size
SD05.TC	SnPb	3,000	7"
SD12.TC	SnPb	3,000	7"
SD05.TCT	Pb free	3,000	7"
SD12.TCT	Pb free	3,000	7"

Contact Information

Semtech Corporation
Protection Products Division
200 Flynn Rd., Camarillo, CA 93012
Phone: (805)498-2111 FAX (805)498-3804