



Chipsmall Limited consists of a professional team with an average of over 10 year of expertise in the distribution of electronic components. Based in Hongkong, we have already established firm and mutual-benefit business relationships with customers from,Europe,America and south Asia,supplying obsolete and hard-to-find components to meet their specific needs.

With the principle of “Quality Parts,Customers Priority,Honest Operation,and Considerate Service”,our business mainly focus on the distribution of electronic components. Line cards we deal with include Microchip,ALPS,ROHM,Xilinx,Pulse,ON,Everlight and Freescale. Main products comprise IC,Modules,Potentiometer,IC Socket,Relay,Connector.Our parts cover such applications as commercial,industrial, and automotives areas.

We are looking forward to setting up business relationship with you and hope to provide you with the best service and solution. Let us make a better world for our industry!



Contact us

Tel: +86-755-8981 8866 Fax: +86-755-8427 6832

Email & Skype: info@chipsmall.com Web: www.chipsmall.com

Address: A1208, Overseas Decoration Building, #122 Zhenhua RD., Futian, Shenzhen, China



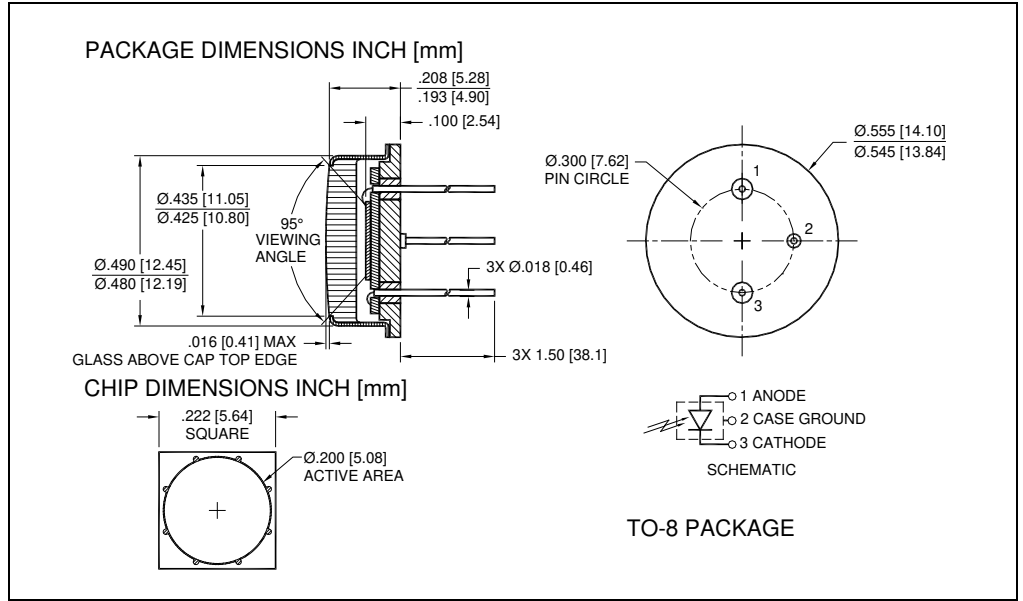

DESCRIPTION

The SD 200-11-31-241 is an ultra low capacitance silicon PIN photodiode, red enhanced, packaged in a leaded hermetic TO-8 metal package.

FEATURES

- Low Noise
- Red Enhanced
- High Shunt Resistance
- High Response

RELIABILITY

Contact Luna for recommendations on specific test conditions and procedures.

APPLICATIONS

- Military
- Industrial
- Medical



ABSOLUTE MAXIMUM RATINGS

SYMBOL	MIN		MAX	UNITS	
Reverse Voltage	-	-	75	V	T _a = 23°C UNLESS OTHERWISE NOTED
Storage Temperature	-55	to	+150	°C	-
Operating Temperature	-40	to	+125	°C	-
Soldering Temperature*	-	-	+240	°C	-

* 1/16 inch from case for 3 seconds max.

OPTO-ELECTRICAL PARAMETERS

T_a = 23°C UNLESS OTHERWISE NOTED

PARAMETER	TEST CONDITIONS	MIN	TYP	MAX	UNITS
Dark Current	V _R = 50V	-	50	200	nA
Junction Capacitance	V _R = 0V, f = 1 MHz	-	110	-	pF
	V _R = 50V, f = 1 MHz	-	11	-	
Spectral Application Range	Spot Scan	350	-	1100	nm
Responsivity	λ = 900nm, V _R = 0V	0.50	0.55	-	A/W
Breakdown Voltage	I = 10 μA	-	75	-	V
Noise Equivalent Power	V _R = 5V @ λ = 950nm	-	3.0x10 ⁻¹³	-	W/√Hz
Response Time**	RL = 50Ω, V _R = 0V	-	190	-	nS
	RL = 50Ω, V _R = 50V	-	8	-	

**Response time of 10% to 90% is specified at 660nm wavelength light.

TYPICAL PERFORMANCE

SPECTRAL RESPONSE

