



Chipsmall Limited consists of a professional team with an average of over 10 year of expertise in the distribution of electronic components. Based in Hongkong, we have already established firm and mutual-benefit business relationships with customers from,Europe,America and south Asia,supplying obsolete and hard-to-find components to meet their specific needs.

With the principle of “Quality Parts,Customers Priority,Honest Operation,and Considerate Service”,our business mainly focus on the distribution of electronic components. Line cards we deal with include Microchip,ALPS,ROHM,Xilinx,Pulse,ON,Everlight and Freescale. Main products comprise IC,Modules,Potentiometer,IC Socket,Relay,Connector.Our parts cover such applications as commercial,industrial, and automotives areas.

We are looking forward to setting up business relationship with you and hope to provide you with the best service and solution. Let us make a better world for our industry!



Contact us

Tel: +86-755-8981 8866 Fax: +86-755-8427 6832

Email & Skype: info@chipsmall.com Web: www.chipsmall.com

Address: A1208, Overseas Decoration Building, #122 Zhenhua RD., Futian, Shenzhen, China



150 W – 50 V moisture resistant HF/VHF DMOS transistor

Datasheet - production data

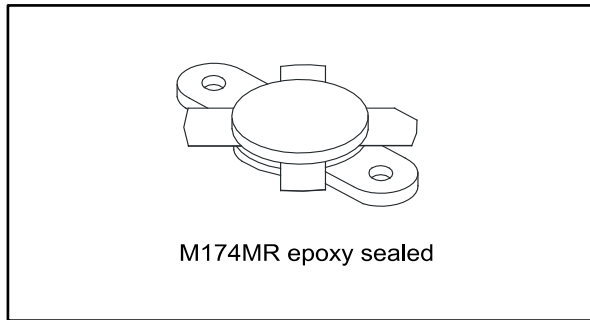
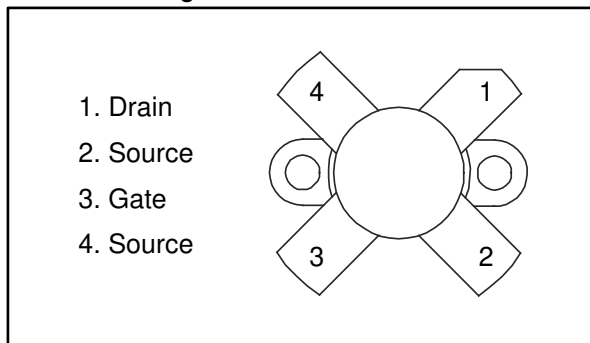

Figure 1: Pin connection



Features

- Gold metallization
- Excellent thermal stability
- Common source push-pull configuration
- $P_{OUT} = 150\text{ W}$ min. with 14 dB gain @ 175 MHz
- Thermally enhanced packing for lower junction temperatures
- G_{FS} and V_{GS} sort marked on unit
- Moisture resistant package specifically designed to operate in extreme environments

Description

The SD2931-12MR is a gold metallized N-channel MOS field-effect RF power transistor. Electrically identical to the standard SD2931 MOSFET, it is used for 50 V DC large signal applications up to 230 MHz.

The SD2931-12MR is mechanically compatible with the SD2931 but offers better thermal capability (25% lower thermal resistance), representing the best-in-class in transistors for ISM applications, where reliability and ruggedness are critical factors.

The SD2931-12MR benefits from the latest generation of environmentally designed packing, ruggedized against cyclic high moisture operation and severe storage conditions.

Table 1: Device summary

Order code	Marking	Package	Packing
SD2931-12MR	SD2931-12MR ⁽¹⁾	M174MR	Plastic tray

Notes:

⁽¹⁾For more details please refer to [Section 5: "Marking, packing and shipping specifications"](#).

Contents

- 1 Electrical data 3**
 - 1.1 Maximum ratings 3
 - 1.2 Thermal data 3
- 2 Electrical characteristics 4**
- 3 Transient thermal impedance 5**
- 4 Typical performance 7**
 - 4.1 Typical performance (175 MHz) 8
 - 4.1.1 Test circuit (175 MHz) 9
 - 4.2 Typical performance (30 MHz) 11
 - 4.2.1 Test circuit (30 MHz) 12
- 5 Marking, packing and shipping specifications 13**
- 6 Package information 14**
 - 6.1 M174MR package information 14
- 7 Revision history 15**

1 Electrical data

1.1 Maximum ratings

$T_{CASE} = 25\text{ °C}$

Table 2: Absolute maximum ratings

Symbol	Parameter	Value	Unit
$V_{(BR)DSS}$	Drain source voltage	125	V
V_{DGR}	Drain-gate voltage ($R_{GS} = 1\text{ M}\Omega$)	125	V
V_{GS}	Gate-source voltage	± 40	V
I_D	Drain current	20	A
P_{DISS}	Power dissipation	389	W
T_J	Max. operating junction temperature	200	$^{\circ}\text{C}$
T_{STG}	Storage temperature	-65 to +150	$^{\circ}\text{C}$

1.2 Thermal data

Table 3: Thermal data

Symbol	Parameter	Value	Unit
R_{thJC}	Junction-to-case thermal resistance	0.45	$^{\circ}\text{C}/\text{W}$

2 Electrical characteristics

T_{CASE} = 25 °C

Table 4: Static

Symbol	Test conditions	Min.	Typ.	Max.	Unit
V _{(BR)DSS}	V _{GS} = 0 V I _{DS} = 100 mA	125			V
I _{DSS}	V _{GS} = 0 V V _{DS} = 5 V			20	
	V _{GS} = 0 V V _{DS} = 50 V			50	μA
I _{GSS}	V _{GS} = 20 V V _{DS} = 0 V			250	nA
V _{GS(Q)} ⁽¹⁾	V _{DS} = 10 V I _D = 250 mA	See table below			V
V _{DS(ON)}	V _{GS} = 10 V I _D = 10 A			3.0	V
G _{FS} ⁽¹⁾	V _{DS} = 10 V I _D = 5 A	See table below			mho
C _{ISS}	V _{GS} = 0 V V _{DS} = 50 V f = 1 MHz		480		pF
C _{OSS}	V _{GS} = 0 V V _{DS} = 50 V f = 1 MHz		190		pF
C _{RSS}	V _{GS} = 0 V V _{DS} = 50 V f = 1 MHz		18		pF

Notes:

⁽¹⁾V_{GS(Q)} and G_{FS} sorted with alpha/numeric code marked on unit.

Table 5: V_{GS} and G_{FS} sorts

Code	V _{GS}	G _{FS}
I	2.65 - 3.15	6.0 - 6.5
J	2.65 - 3.15	6.5 - 7.0
K	2.65 - 3.15	7.0 - 7.5

Table 6: Dynamic

Symbol	Test conditions	Min.	Typ.	Max.	Unit
P _{OUT}	V _{DD} = 50 V I _{DQ} = 250 mA f = 175 MHz	150			W
G _{PS}	V _{DD} = 50 V I _{DQ} = 250 mA P _{OUT} = 150 W f = 175 MHz	14	15		dB
η _D	V _{DD} = 50 V I _{DQ} = 250 mA P _{OUT} = 150 W f = 175 MHz	55	65		%
Load mismatch	V _{DD} = 50 V I _{DQ} = 250 mA P _{OUT} = 150 W f = 175 MHz all phase angles	10:1			VSWR

3 Transient thermal impedance

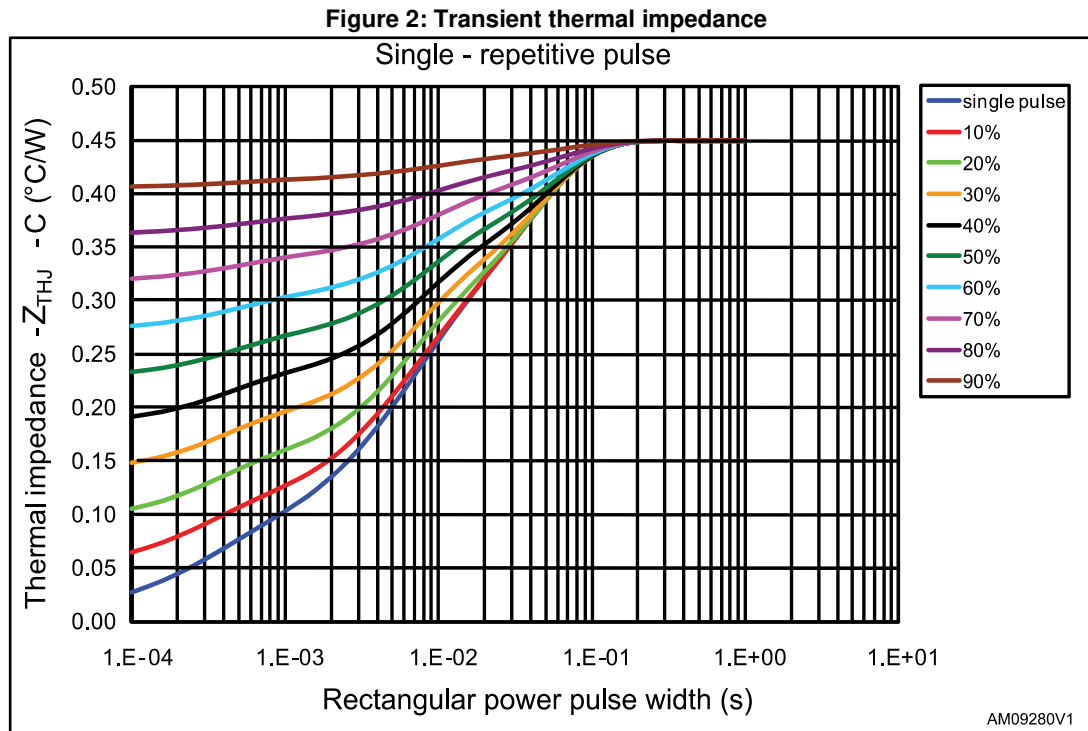
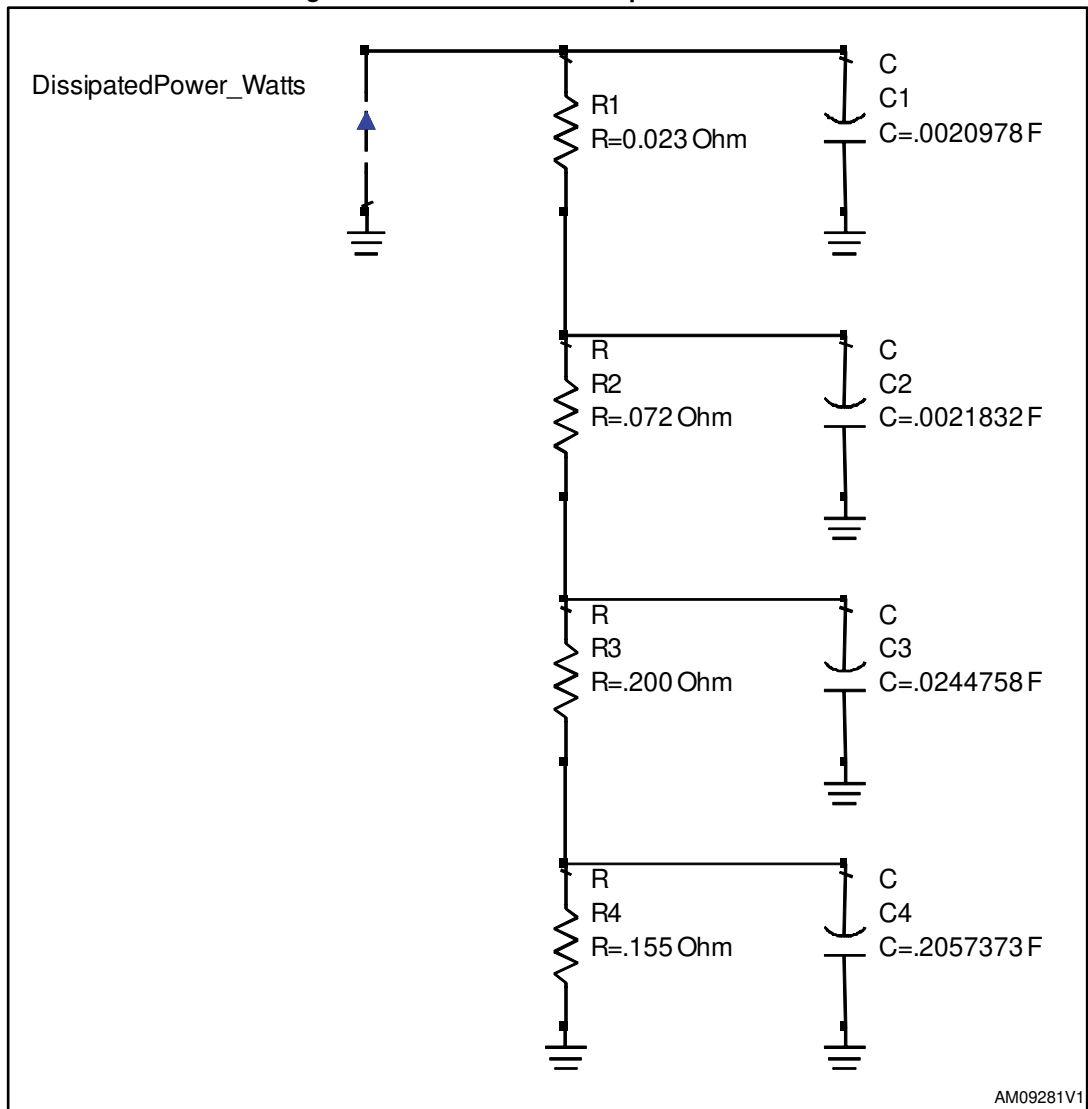
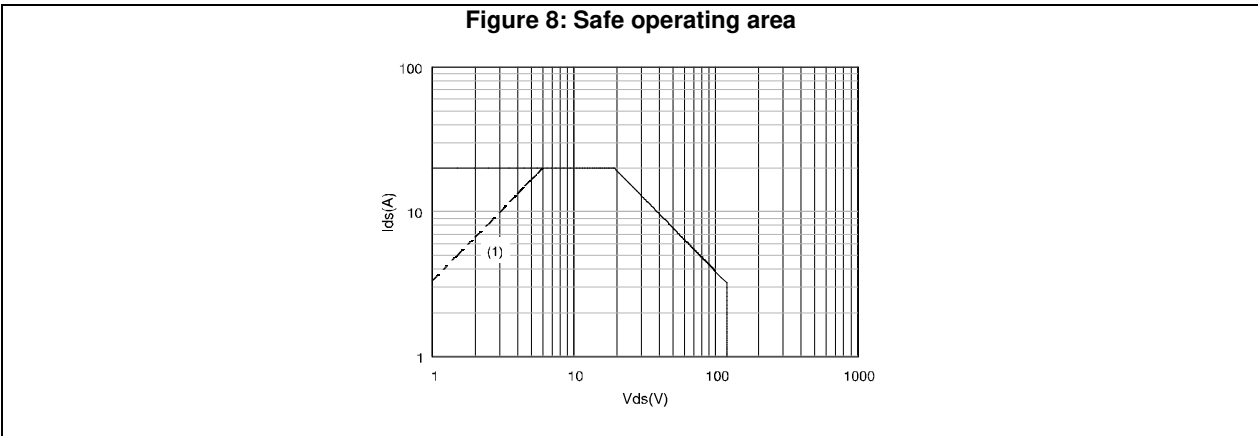
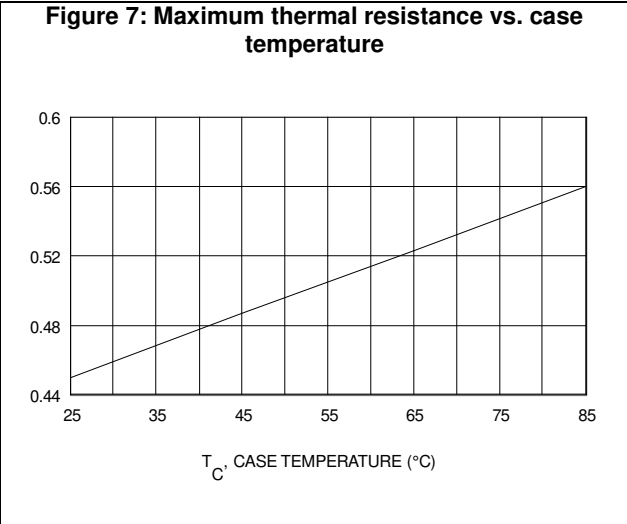
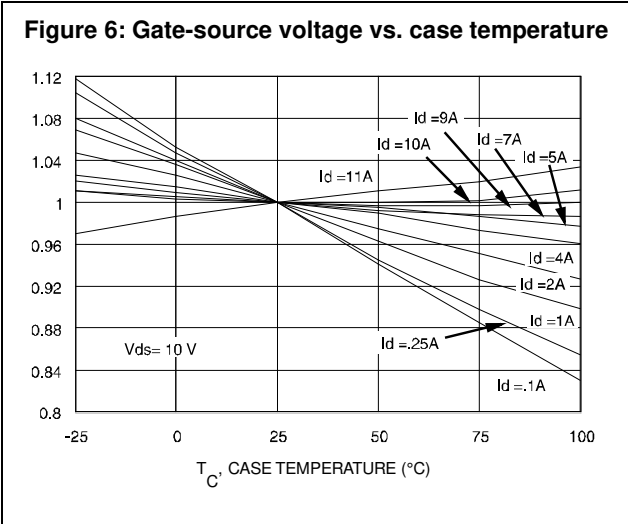
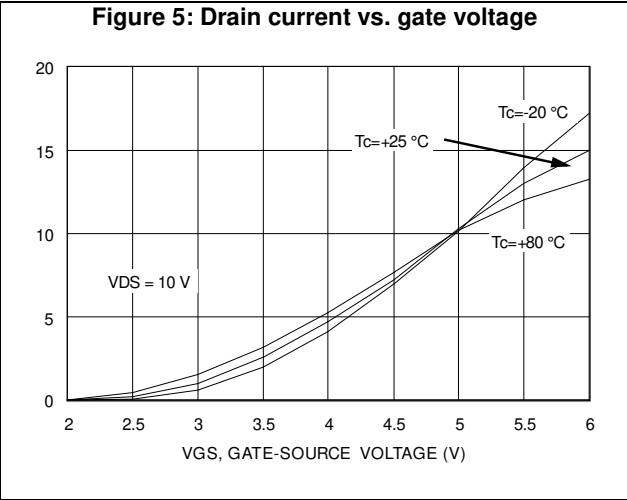
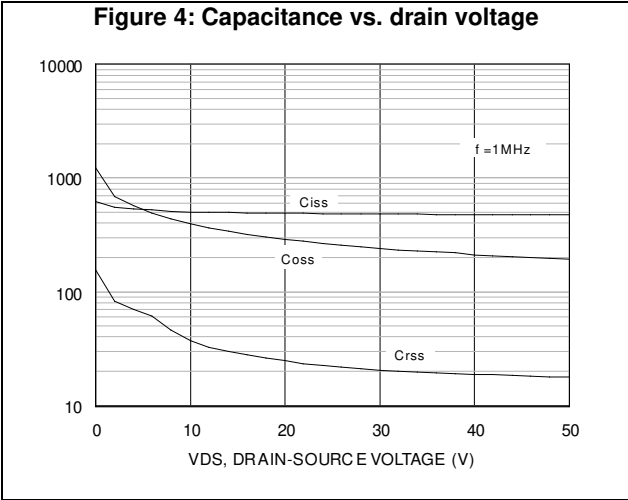

Figure 3: Transient thermal impedance model



4 Typical performance



4.1 Typical performance (175 MHz)

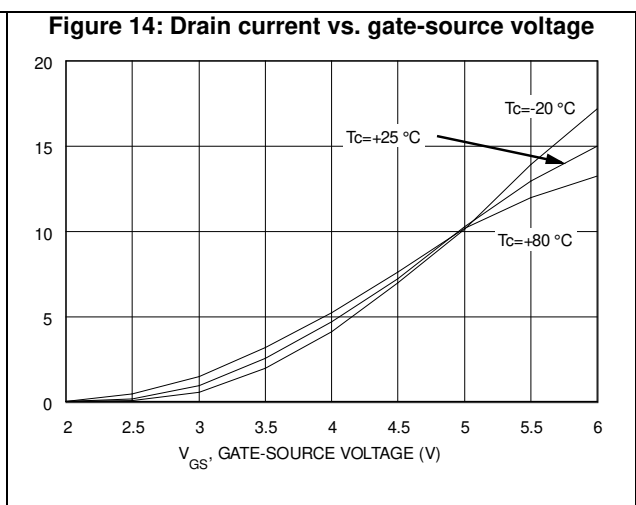
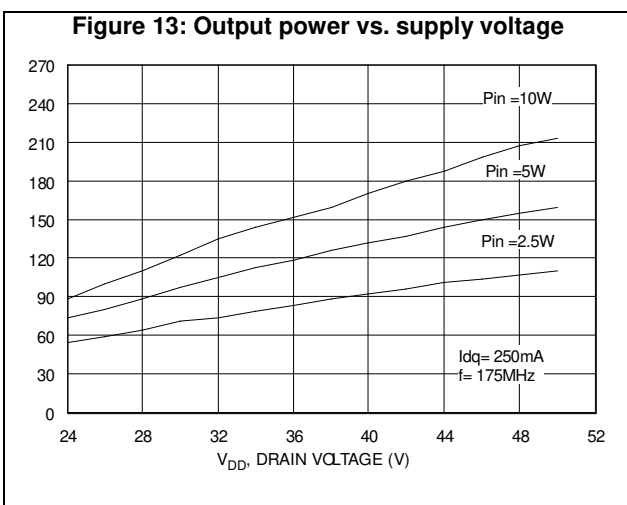
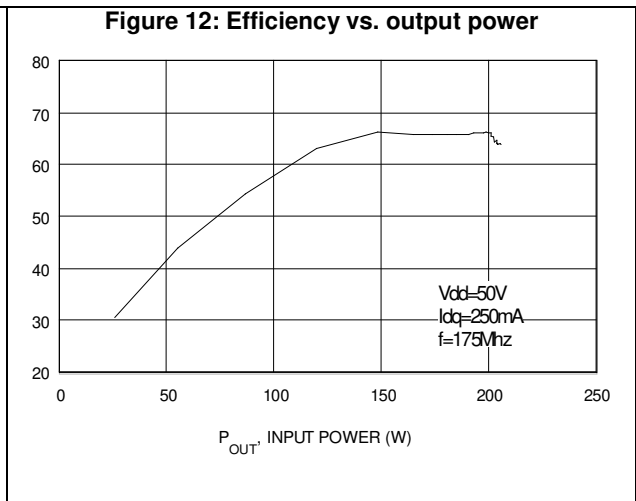
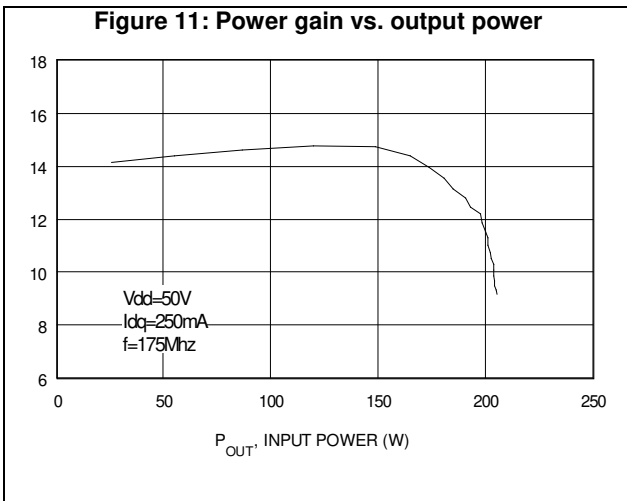
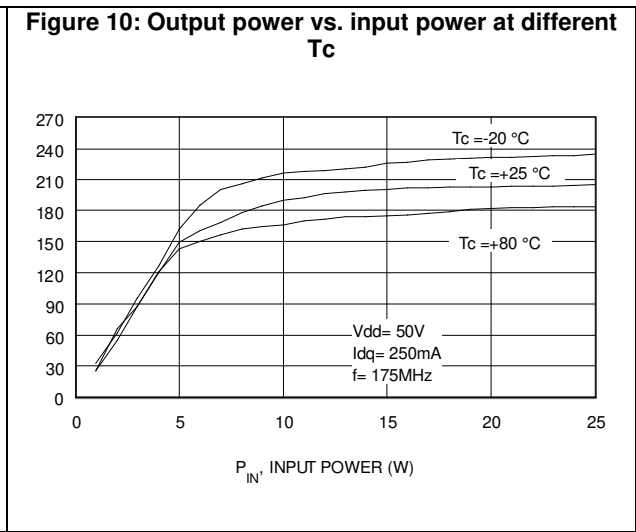
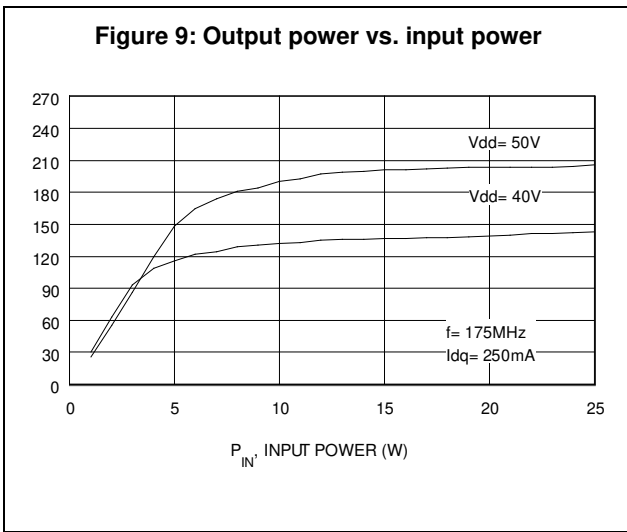

4.1.1 Test circuit (175 MHz)

Figure 15: 175 MHz test circuit schematic (production test circuit)

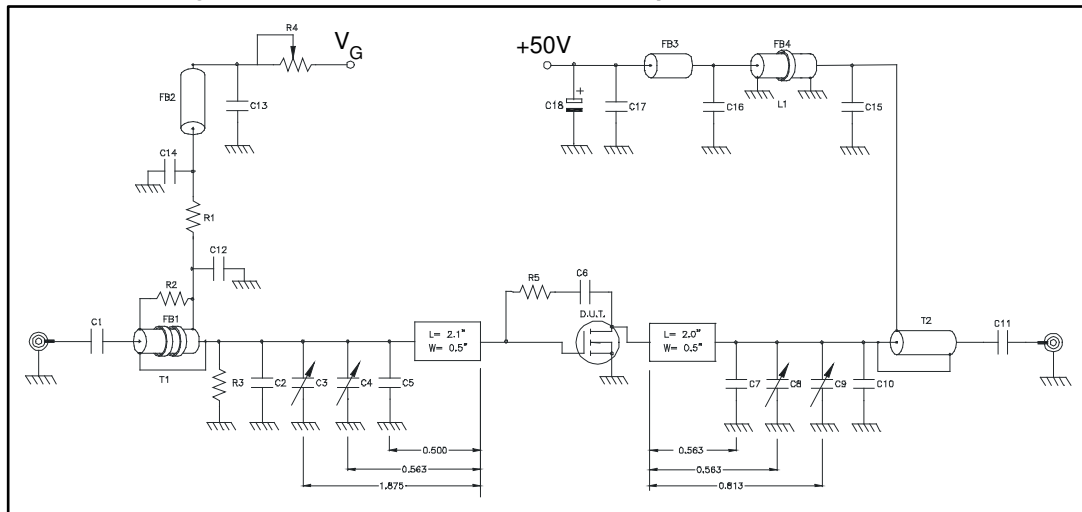

Table 7: 175 MHz test circuit part list

Component	Description
T1	4:1 transformer, 25 Ω flexible coax .090 OD 6" long
T2	1:4 transformer, 25 Ω semi-rigid coax .141 OD 6" long
FB1	Toroid X 2, 0.5" OD .312" ID 850 μ 2 turns
FB2, FB3	VK200
FB4	Shield bead, 1" OD 0.5" ID 850 μ 3 turns
L1	1/4 wave choke, 50 Ω semi-rigid coax .141 OD 12" long
PCB	0.62" woven fiberglass, 1 oz. copper, 2 sides, $\epsilon_r = 2.55$
R1, R3	470 Ω 1 W chip resistor
R2	360 Ω 1/2 W resistor
R4	20 k Ω 10 turn potentiometer
R5	560 Ω 1 W resistor
C1, C11	470 pF ATC chip cap
C2	43 pF ATC chip cap
C3, C8, C9	Arco 404, 12-65 pF
C4	Arco 423, 16-100 pF
C5	120 pF ATC chip cap
C6	0.01 μ F ATC chip cap
C7	30 pF ATC chip cap
C10	91 pF ATC chip cap
C12, C15	1200 pF ATC chip cap
C13, C14, C16, C17	0.01 μ F / 500 V chip cap
C18	10 μ F 63 V electrolytic capacitor

Figure 16: 175 MHz test circuit photomaster

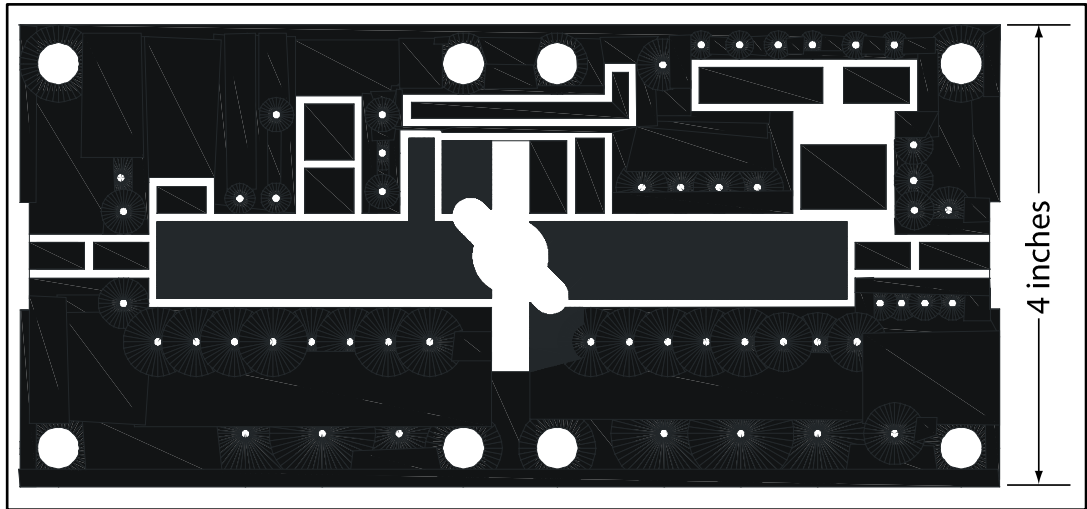
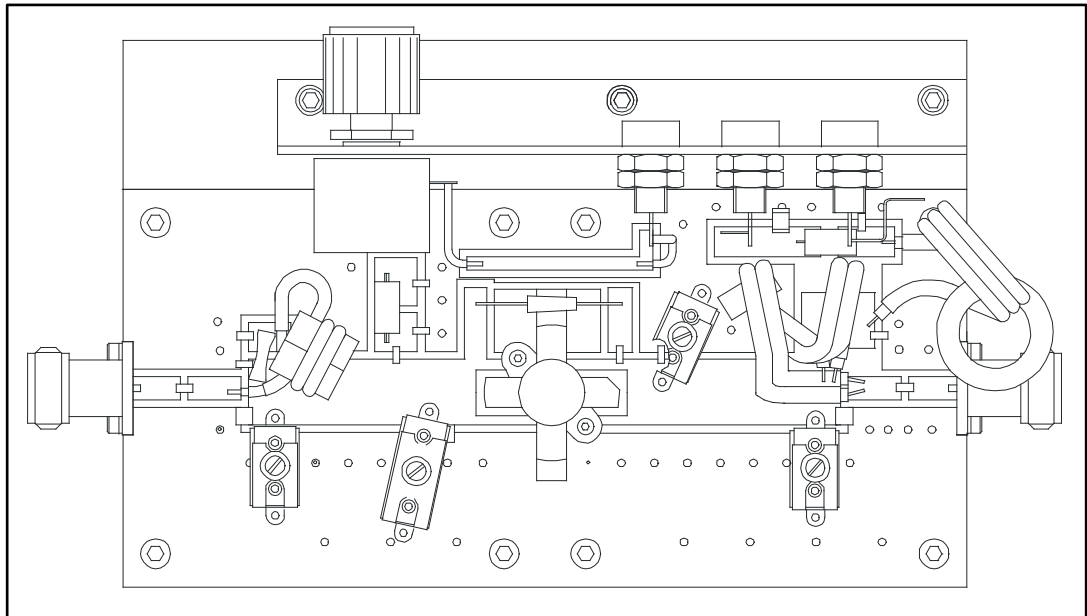
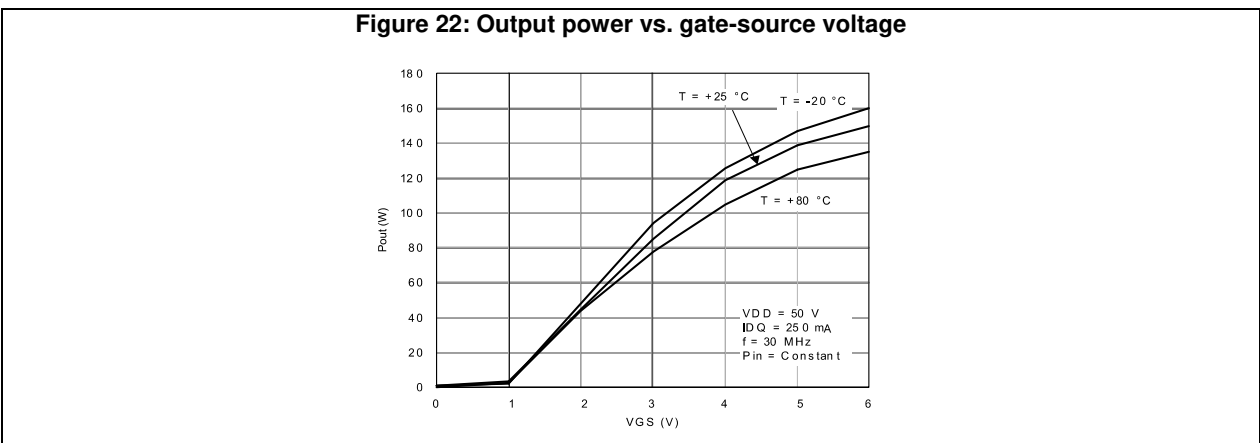
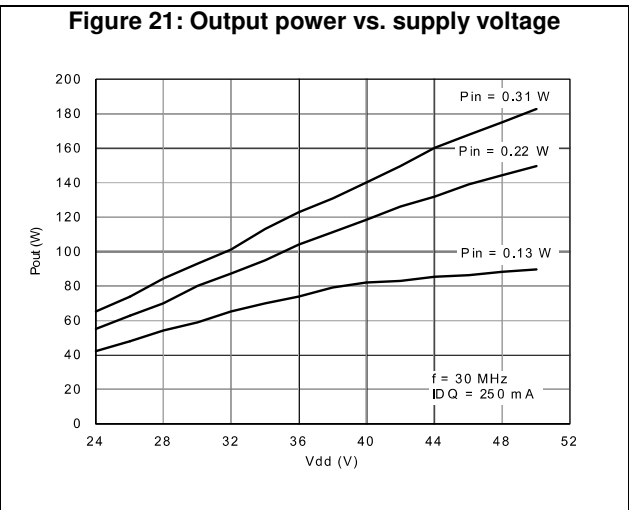
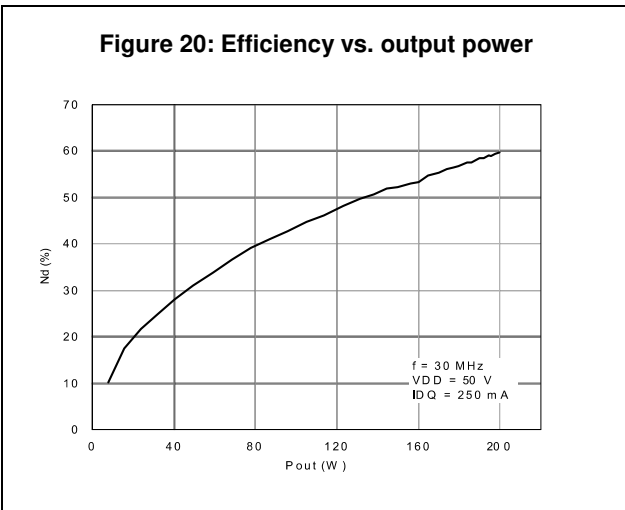
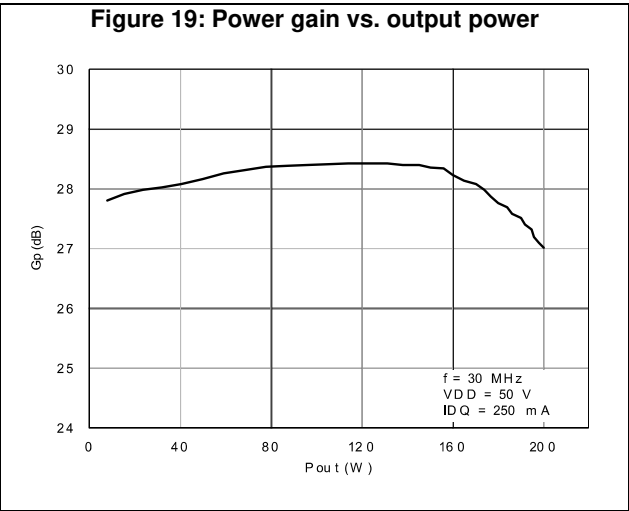
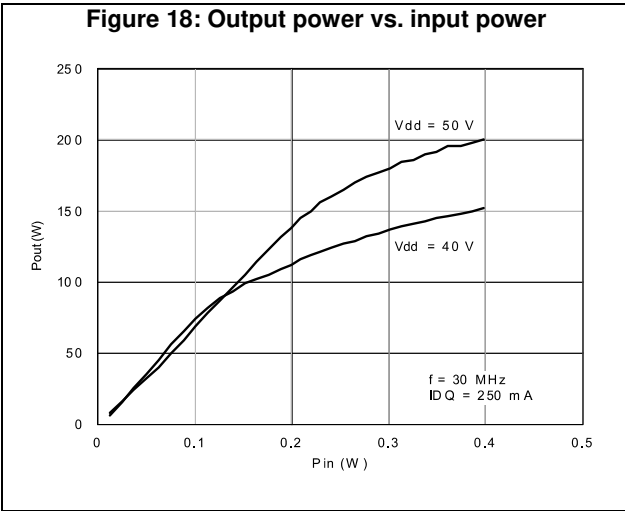

Figure 17: 175 MHz test circuit



4.2 Typical performance (30 MHz)



4.2.1 Test circuit (30 MHz)

Figure 23: 30 MHz test circuit schematic (production test circuit)

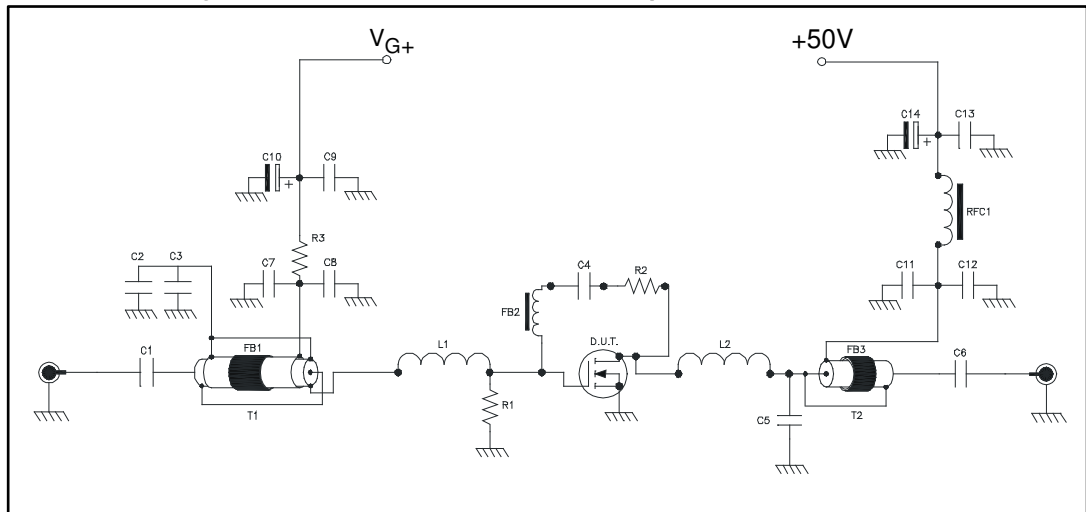

Table 8: 30 MHz test circuit part list

Component	Description
T1	9:1 transformer, 25 Ω flexible coax with extra shield .090 OD 15" long
T2	1:4 transformer, 50 Ω flexible coax .225 OD 15" long
FB1	Toroid 1.7" OD .30" ID 220 μ 4 turns
FB2	Surface mount EMI shield bead
FB3	Toroid 1.7" OD .300" ID 220 μ 3 turns
RFC1	Toroid 0.5" OD 0.30" ID 125 μ 4 turns 12 awg wire
PCB	0.62" woven fiberglass, 1 oz. copper, 2 sides, εr = 2.55
R1, R3	1 kohm 1 W chip resistor
R2	680 ohm 3 W wirewound resistor
C1, C4, C6, C7, C8, C9, C11, C12, C13	0.1 μF ATC chip cap
C2, C3	750 pF ATC chip cap
C5	470 pF ATC chip cap
C10	10 μF 63 V electrolytic capacitor
C14	100 μF 63 V electrolytic capacitor

5 Marking, packing and shipping specifications

Table 9: Packing and shipping specifications

Order code	Packing	Pieces per tray	Dry pack humidity	V _{GS} and G _{FS} code	Lot code
SD2931-12MR	Plastic tray	25	< 10%	Not mixed	Not mixed

Figure 24: SD2931-12MR marking layout

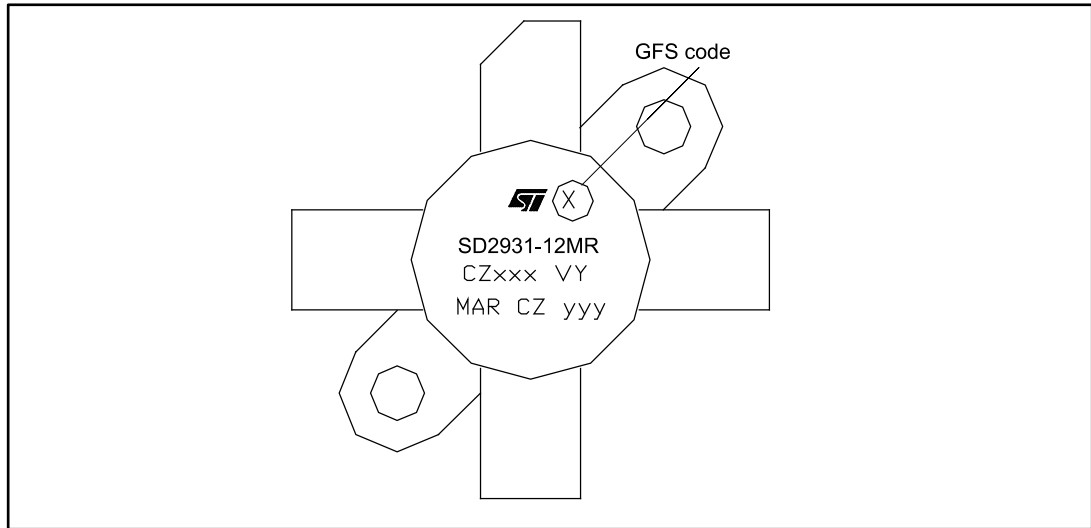

Table 10: Marking specifications

Symbol	Description
X	V _{GS} and G _{FS} sort
CZ	Assembly plant
xxx	Last 3 digits of diffusion lot
VY	Diffusion plant
MAR	Country of origin
CZ	Test and finishing plant
y	Assembly year
yy	Assembly week

6 Package information

In order to meet environmental requirements, ST offers these devices in different grades of ECOPACK® packages, depending on their level of environmental compliance. ECOPACK® specifications, grade definitions and product status are available at: www.st.com. ECOPACK® is an ST trademark.

6.1 M174MR package information

Figure 25: M174MR package outline

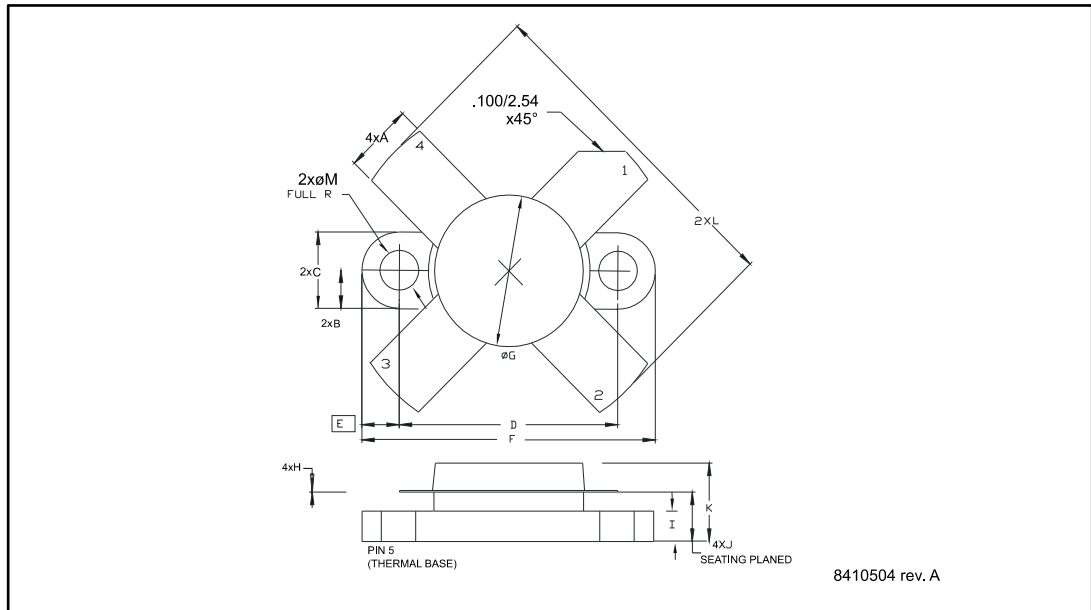

Table 11: M174MR package mechanical data

Dim.	mm		
	Min.	Typ.	Max.
A	5.56		5.584
B		3.18	
C	6.22		6.48
D	18.28		18.54
E		3.18	
F	24.64		24.89
G	12.07		12.83
H	0.08		0.18
I	2.11		3.00
J	3.81		4.45
K			8.00
L	25.53		26.67
M	3.05		3.30

7 Revision history

Table 12: Document revision history

Date	Revision	Changes
20-Feb-2013	1	Initial release
10-Sep-2013	2	Document promoted from preliminary data to full datasheet. Formatting and minor text changes.
11-Nov-2016	3	Updated Table 2: "Absolute maximum ratings" .

IMPORTANT NOTICE – PLEASE READ CAREFULLY

STMicroelectronics NV and its subsidiaries ("ST") reserve the right to make changes, corrections, enhancements, modifications, and improvements to ST products and/or to this document at any time without notice. Purchasers should obtain the latest relevant information on ST products before placing orders. ST products are sold pursuant to ST's terms and conditions of sale in place at the time of order acknowledgement.

Purchasers are solely responsible for the choice, selection, and use of ST products and ST assumes no liability for application assistance or the design of Purchasers' products.

No license, express or implied, to any intellectual property right is granted by ST herein.

Resale of ST products with provisions different from the information set forth herein shall void any warranty granted by ST for such product.

ST and the ST logo are trademarks of ST. All other product or service names are the property of their respective owners.

Information in this document supersedes and replaces information previously supplied in any prior versions of this document.

© 2016 STMicroelectronics – All rights reserved