



Chipsmall Limited consists of a professional team with an average of over 10 year of expertise in the distribution of electronic components. Based in Hongkong, we have already established firm and mutual-benefit business relationships with customers from,Europe,America and south Asia,supplying obsolete and hard-to-find components to meet their specific needs.

With the principle of “Quality Parts,Customers Priority,Honest Operation,and Considerate Service”,our business mainly focus on the distribution of electronic components. Line cards we deal with include Microchip,ALPS,ROHM,Xilinx,Pulse,ON,Everlight and Freescale. Main products comprise IC,Modules,Potentiometer,IC Socket,Relay,Connector.Our parts cover such applications as commercial,industrial, and automotives areas.

We are looking forward to setting up business relationship with you and hope to provide you with the best service and solution. Let us make a better world for our industry!



Contact us

Tel: +86-755-8981 8866 Fax: +86-755-8427 6832

Email & Skype: info@chipsmall.com Web: www.chipsmall.com

Address: A1208, Overseas Decoration Building, #122 Zhenhua RD., Futian, Shenzhen, China



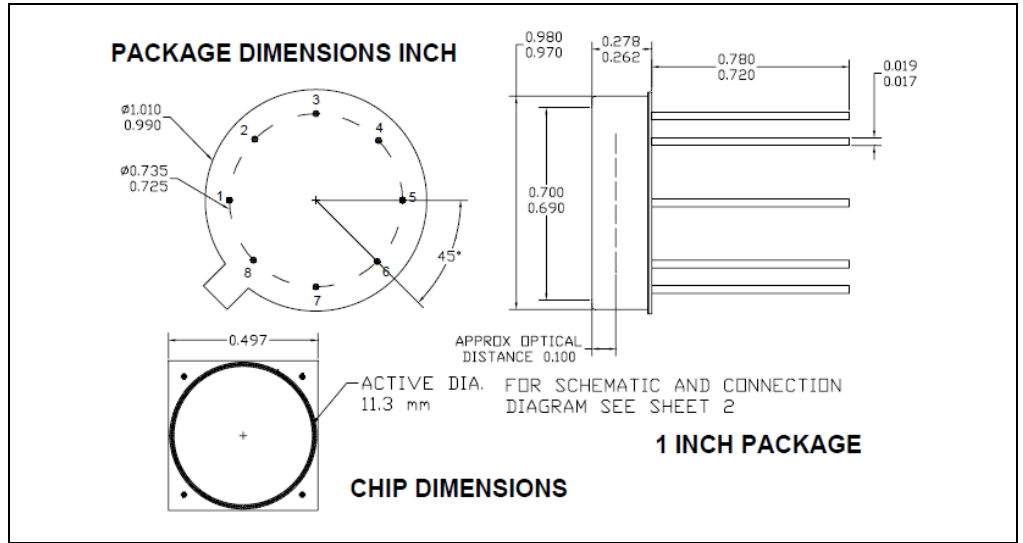
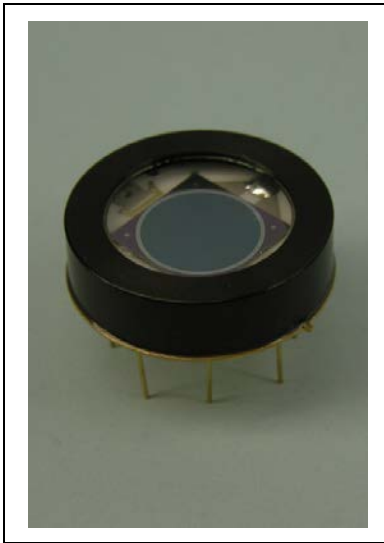

DESCRIPTION

The SD 444-42-22-261 is a detector/amplifier hybrid that combines a silicon photodiode with an opamp without the feedback resistor and capacitor, available in a hermetic metal can package.

FEATURES

- Low Noise
- Blue Enhanced
- Custom Feedback
- High Speed

RELIABILITY

Contact Luna for recommendations on specific test conditions and procedures.

APPLICATIONS

- Instrumentation
- Medical
- Industrial



ABSOLUTE MAXIMUM RATINGS

T_a = 23°C UNLESS OTHERWISE NOTED

SYMBOL	MIN	TYPE	MAX	UNITS
Voltage Supplies	±5	±15	±18	V
Input Offset Voltage	-	1	2	mV
Input Voltage Noise@ f=10KHz	-	12	-	nV/√Hz
Input Bias Current	-	15	40	pA
Input Offset Current	-	20	30	pA
Input Current Noise @ f=10KHz	-	20	30	fA/√Hz
Gain Bandwidth Product	-	18	-	MHz
Supply Current	-	6.5	7	mA
Storage Temperature	-65	-	+125	°C
Operating Temperature	-40	-	-85	°C

Information in this technical datasheet is believed to be correct and reliable. However, no responsibility is assumed for possible inaccuracies or omission. Specifications are subject to change without notice.

OPTO-ELECTRICAL PARAMETERS

$T_a = 23^\circ\text{C}$ UNLESS NOTED OTHERWISE

PARAMETER	TEST CONDITIONS	MIN	TYP	MAX	UNITS
Dark Current	$V_R = 10\text{ V}$	-	-	150	nA
Shunt Resistance	$V_R = 0\text{ V}$	15	-	-	$M\Omega$
Junction Capacitance	$V_R = 0\text{V}; f = 1\text{ MHz}$	-	1700	-	pF
	$V_R = 10\text{V}; f = 1\text{ MHz}$	-	340	-	
Spectral Application Range	Spot Scan	250	-	1100	nm
Responsivity	$\lambda = 450\text{nm}, V_R = 0\text{ V}$	-	.28	-	-

TYPICAL PERFORMANCE

SPECTRAL RESPONSE

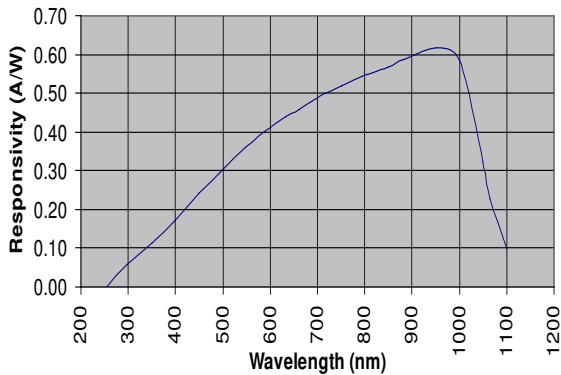

SCHEMATIC AND CONNECTION DIAGRAM

PHOTOVOLTAIC MODE

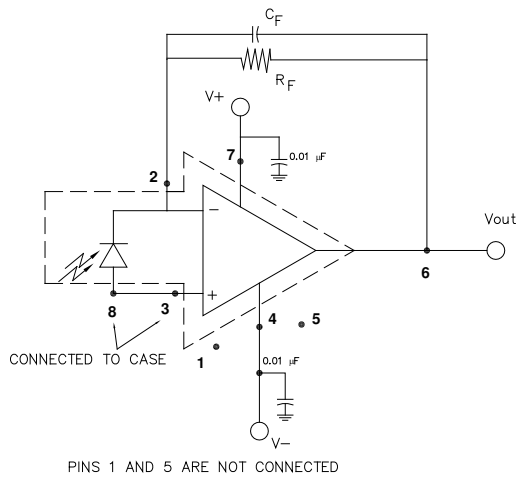

Note: Components shown outside the dashed area are external to the device, and must be supplied by the user.

PHOTOCONDUCTIVE MODE

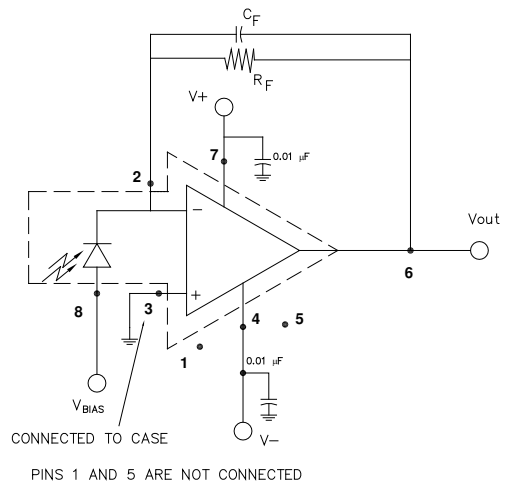

Note: Components shown outside the dashed area are external to the device, and must be supplied by the user.