



Chipsmall Limited consists of a professional team with an average of over 10 year of expertise in the distribution of electronic components. Based in Hongkong, we have already established firm and mutual-benefit business relationships with customers from,Europe,America and south Asia,supplying obsolete and hard-to-find components to meet their specific needs.

With the principle of “Quality Parts,Customers Priority,Honest Operation,and Considerate Service”,our business mainly focus on the distribution of electronic components. Line cards we deal with include Microchip,ALPS,ROHM,Xilinx,Pulse,ON,Everlight and Freescale. Main products comprise IC,Modules,Potentiometer,IC Socket,Relay,Connector.Our parts cover such applications as commercial,industrial, and automotives areas.

We are looking forward to setting up business relationship with you and hope to provide you with the best service and solution. Let us make a better world for our industry!



## Contact us

Tel: +86-755-8981 8866 Fax: +86-755-8427 6832

Email & Skype: info@chipsmall.com Web: www.chipsmall.com

Address: A1208, Overseas Decoration Building, #122 Zhenhua RD., Futian, Shenzhen, China



## 50 V moisture resistant DMOS transistor for ISM applications

Datasheet - preliminary data

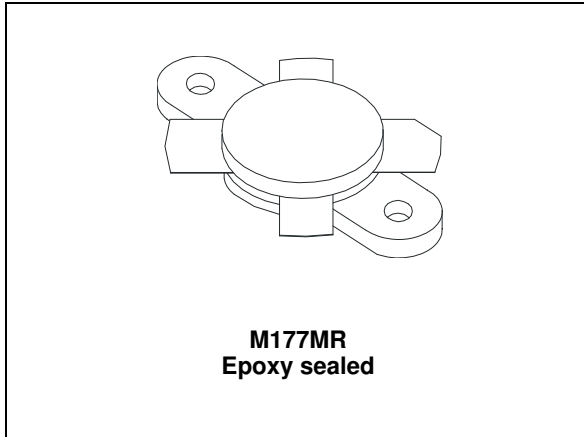

**Figure 1. Pin connection**

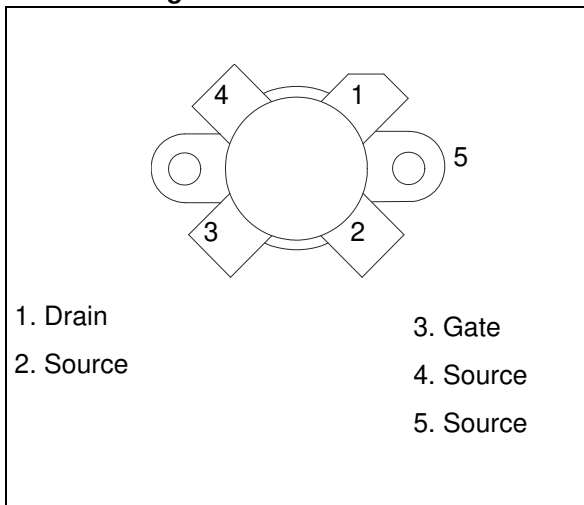

### Features

- Improved ruggedness  $V_{(BR)DSS} > 200\text{ V}$
- Excellent thermal stability
- 20:1 all phases load mismatch capability
- $P_{OUT} = 300\text{ W}$  min. with 24 dB gain @ 30 MHz
- In compliance with the 2002/95/EEC European directive
- Moisture resistant package specifically designed to operate under extreme environments

### Description

The SD4933MR is an N-channel MOS field-effect RF power transistor. It is intended for use in 50 V ISM applications up to 100 MHz.

The SD4933MR benefits from the latest generation of environmentally designed packaging, ruggedized against cyclic high moisture operating and severe storage conditions.

**Table 1. Device summary**

Order code	Marking	Base qty.	Package	Packaging
SD4933MR	SD4933MR <sup>(1)</sup>	25 pcs	M177MR	Plastic tray

1. For more details please refer to [Chapter 8: Marking, packing and shipping specifications](#).

# Contents

- 1      Electrical data ..... 3**
  - 1.1    Maximum ratings ..... 3
  - 1.2    Thermal data ..... 3
- 2      Electrical characteristics ..... 4**
  - 2.1    Static ..... 4
  - 2.2    Dynamic ..... 4
- 3      Impedance data ..... 5**
- 4      Typical performance ..... 6**
- 5      Typical performance (30 MHz) ..... 9**
  - 5.1    Test circuit (30 MHz) ..... 10
- 6      Circuit layout ..... 12**
- 7      V<sub>GS</sub>/G<sub>FS</sub> sorts ..... 13**
- 8      Marking, packing and shipping specifications ..... 16**
- 9      Package mechanical data ..... 17**
- 10     Revision history ..... 19**

# 1 Electrical data

## 1.1 Maximum ratings

( $T_{CASE} = 25\text{ °C}$ )

**Table 2. Absolute maximum ratings**

Symbol	Parameter	Value	Unit
$V_{(BR)DSS}$	Drain source voltage	200	V
$V_{DGR}$	Drain-gate voltage ( $R_{GS} = 1\text{ M}\Omega$ )	200	V
$V_{GS}$	Gate-source voltage	$\pm 20$	V
$I_D$	Drain current	40	A
$P_{DISS}$	Power dissipation	648	W
$E_{AS}$	Avalanche energy Single pulse ( $I_D = 56\text{ A} - 800\text{ }\mu\text{H}$ coil)	1200	mJ
$T_J$	Max. operating junction temperature	200	$^{\circ}\text{C}$
$T_{STG}$	Storage temperature	-65 to +150	$^{\circ}\text{C}$

## 1.2 Thermal data

**Table 3. Thermal data**

Symbol	Parameter	Value	Unit
$R_{thJC}$	Junction - case thermal resistance	0.27	$^{\circ}\text{C}/\text{W}$

## 2 Electrical characteristics

( $T_{CASE} = 25\text{ }^{\circ}\text{C}$ )

### 2.1 Static

Table 4. Static

Symbol	Test conditions		Min	Typ	Max	Unit
$V_{(BR)DSS}$	$V_{GS} = 0\text{ V}$	$I_{DS} = 100\text{ mA}$	200	240		V
$I_{DSS}$	$V_{GS} = 0\text{ V}$	$V_{DS} = 100\text{ V}$			2	mA
$I_{GSS}$	$V_{GS} = 20\text{ V}$	$V_{DS} = 0\text{ V}$			1	$\mu\text{A}$
$V_{TH}$	$I_D = 250\text{ mA}$		1.5	2.5	4.0	V
$V_{DS(ON)}$	$V_{GS} = 10\text{ V}$	$I_D = 20\text{ A}$		3.5	4.0	V
$G_{FS}$	$V_{DS} = 10\text{ V}$	$I_D = 5\text{ A}$	5	8		S
$C_{ISS}$	$V_{GS} = 0\text{ V}$	$V_{DS} = 50\text{ V}$		1000		pF
$C_{OSS}$	$V_{GS} = 0\text{ V}$	$V_{DS} = 50\text{ V}$		400		pF
$C_{RSS}$	$V_{GS} = 0\text{ V}$	$V_{DS} = 50\text{ V}$		16		pF

### 2.2 Dynamic

Table 5. Dynamic

Symbol	Test conditions		Min	Typ	Max	Unit
$P_{OUT}$	$V_{DD} = 50\text{ V}$	$I_{DQ} = 250\text{ mA}$ $f = 30\text{ MHz}$	300		-	W
$G_{PS}$	$V_{DD} = 50\text{ V}$	$I_{DQ} = 250\text{ mA}$ $P_{OUT} = 300\text{ W}$ $f = 30\text{ MHz}$	20	24	-	dB
$h_D$	$V_{DD} = 50\text{ V}$	$I_{DQ} = 250\text{ mA}$ $P_{OUT} = 300\text{ W}$ $f = 30\text{ MHz}$	50	58	-	%
Load mismatch	$V_{DD} = 50\text{ V}$	$I_{DQ} = 250\text{ mA}$ $P_{OUT} = 300\text{ W}$ $f = 30\text{ MHz}$ All phase angles	10:1	20:1	-	VSWR

### 3 Impedance data

Figure 2. Impedance data

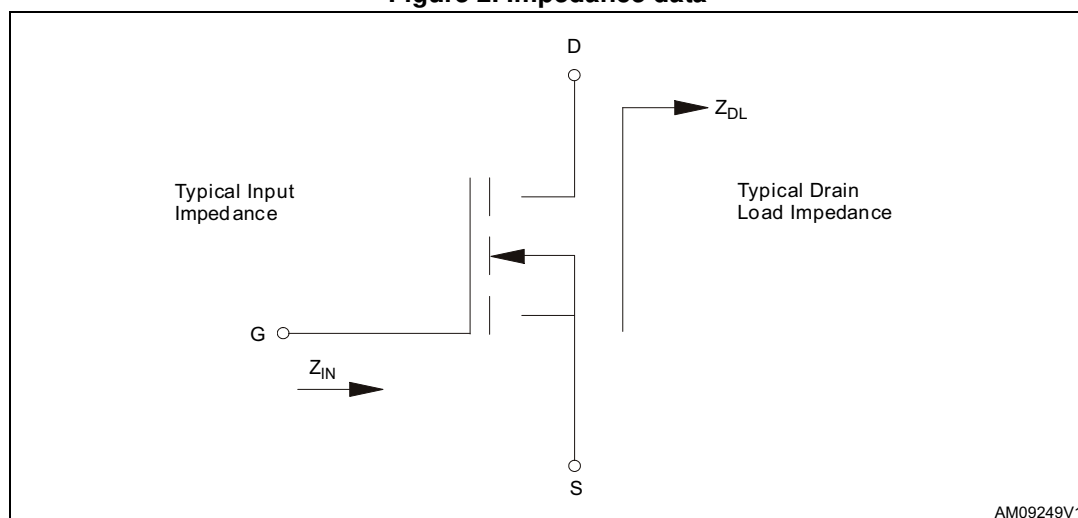

Table 6. Impedance values

$Z_{in}$	$Z_{dl}$
1.6 - j 5.0	3.3 + j 1.0



## 4 Typical performance

Figure 3. Capacitance vs. drain voltage

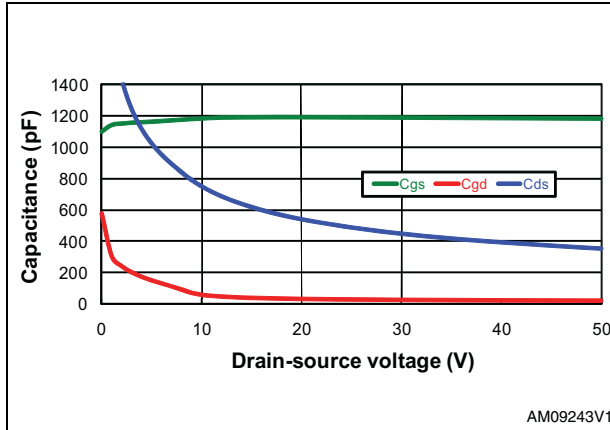

Figure 4. Drain current vs. drain-source voltage

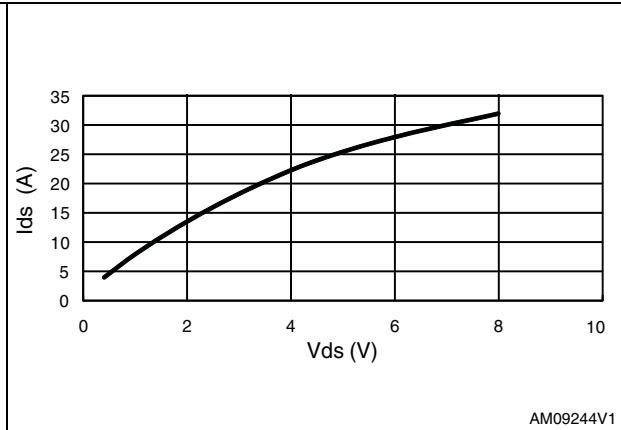

Figure 5. Drain current vs. drain-source voltage at different temperatures

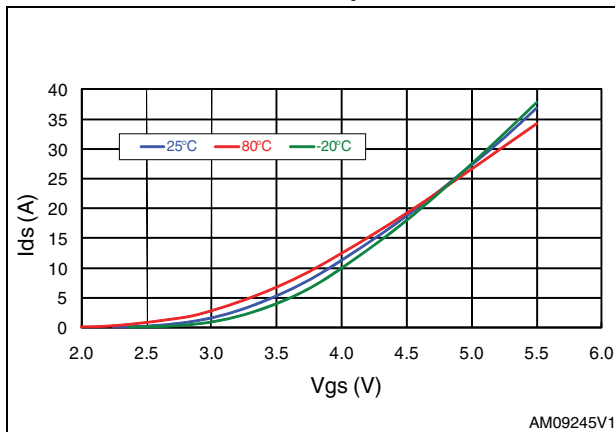

Figure 6. Transient thermal impedance

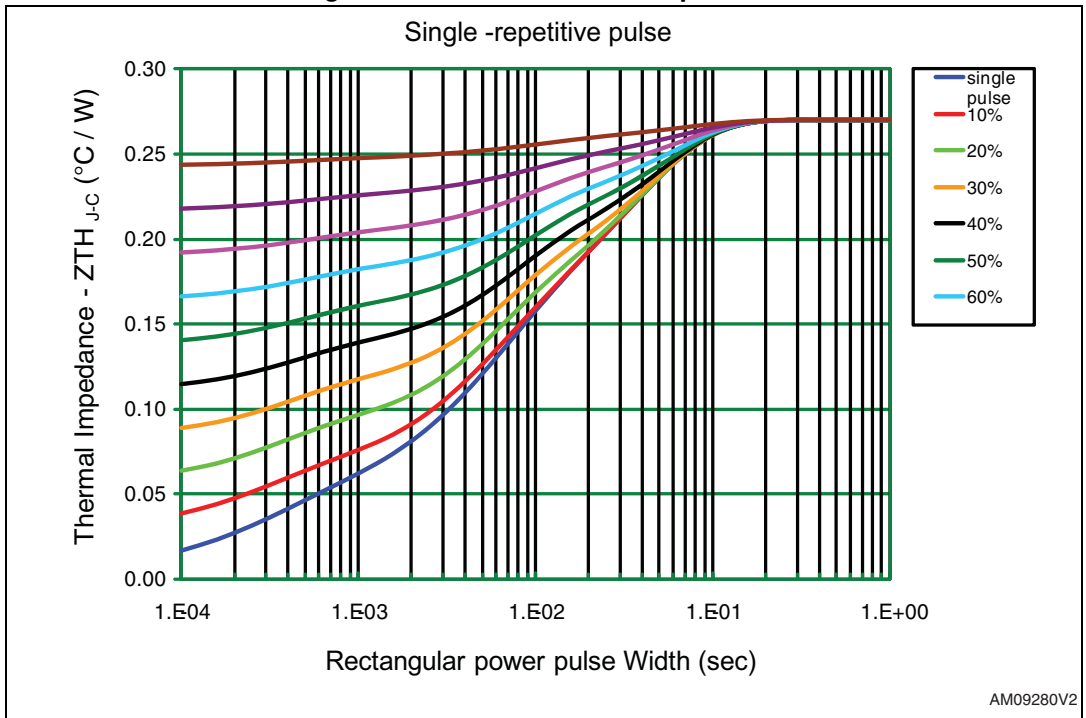
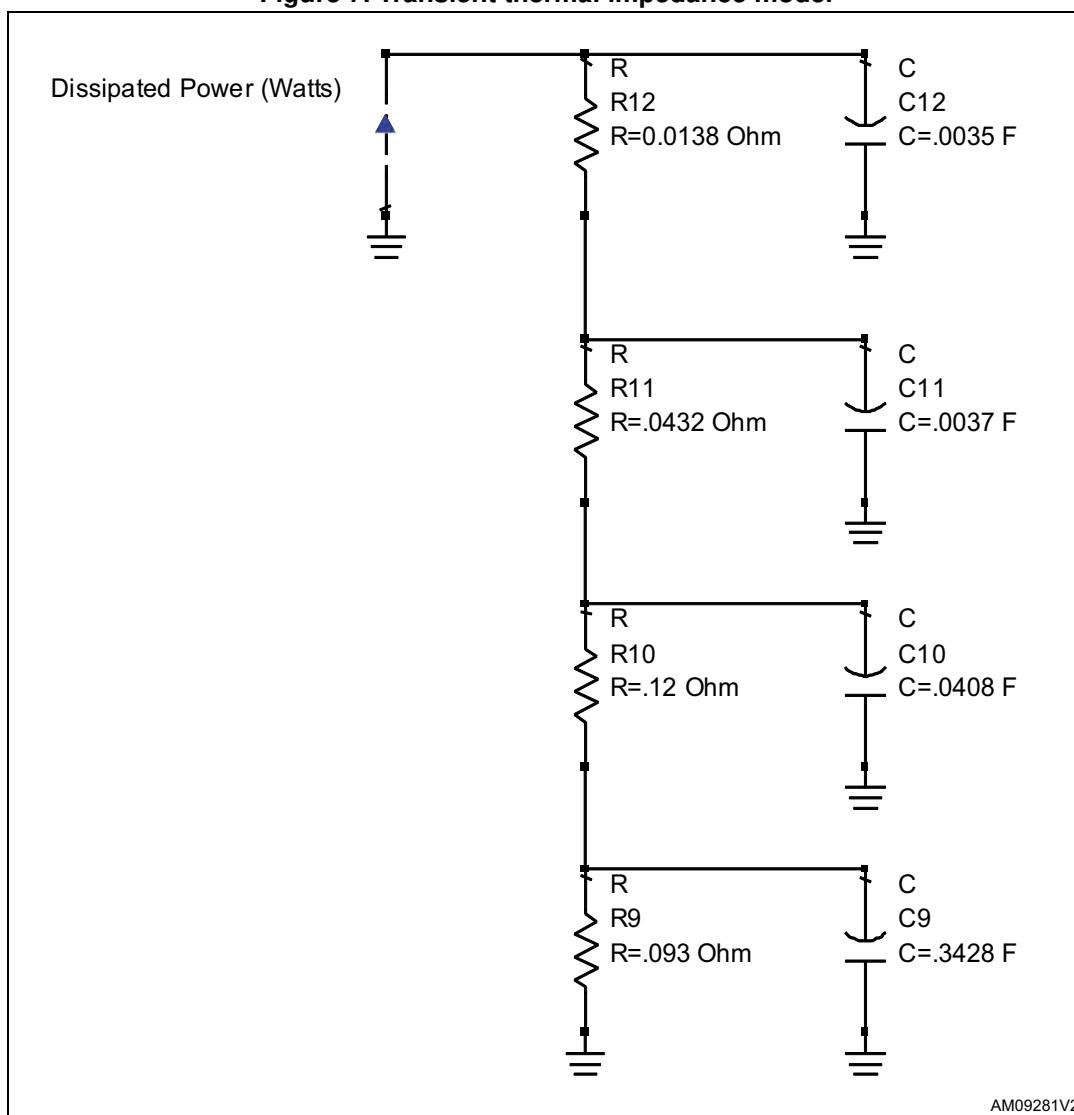



Figure 7. Transient thermal impedance model



## 5 Typical performance (30 MHz)

Figure 8. Gain and efficiency vs. output power at  $V_{dd} = 50\text{ V}$ ,  $I_{dq} = 250\text{ mA}$ ,  $f_{req} = 30\text{ MHz}$

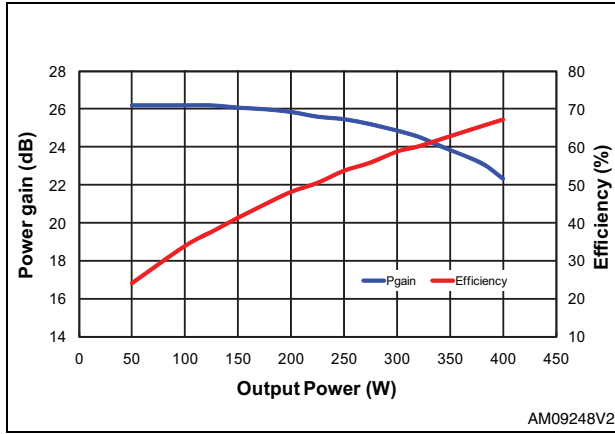

Figure 9. Output power vs. input power

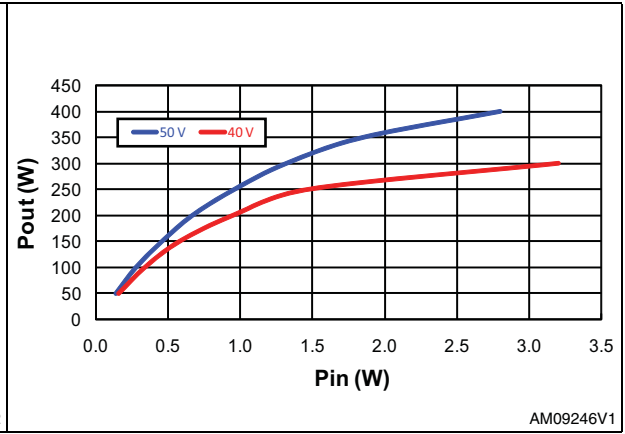

Figure 10. Output power vs. supply voltage

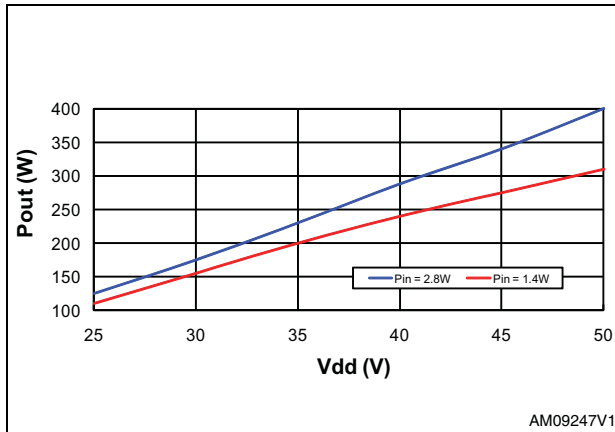
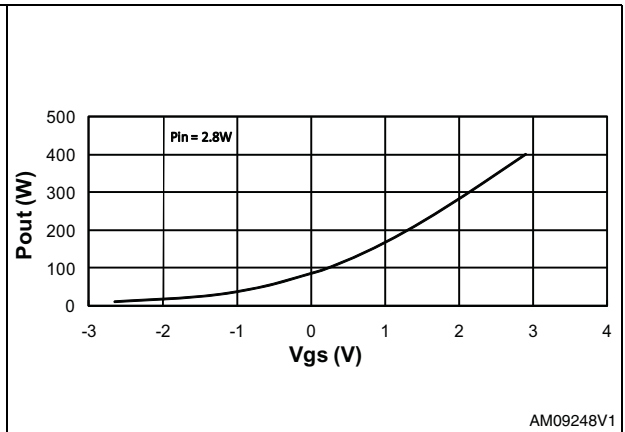

Figure 11. Output power vs. gate voltage



### 5.1 Test circuit (30 MHz)

Figure 12. 30 MHz test circuit schematic

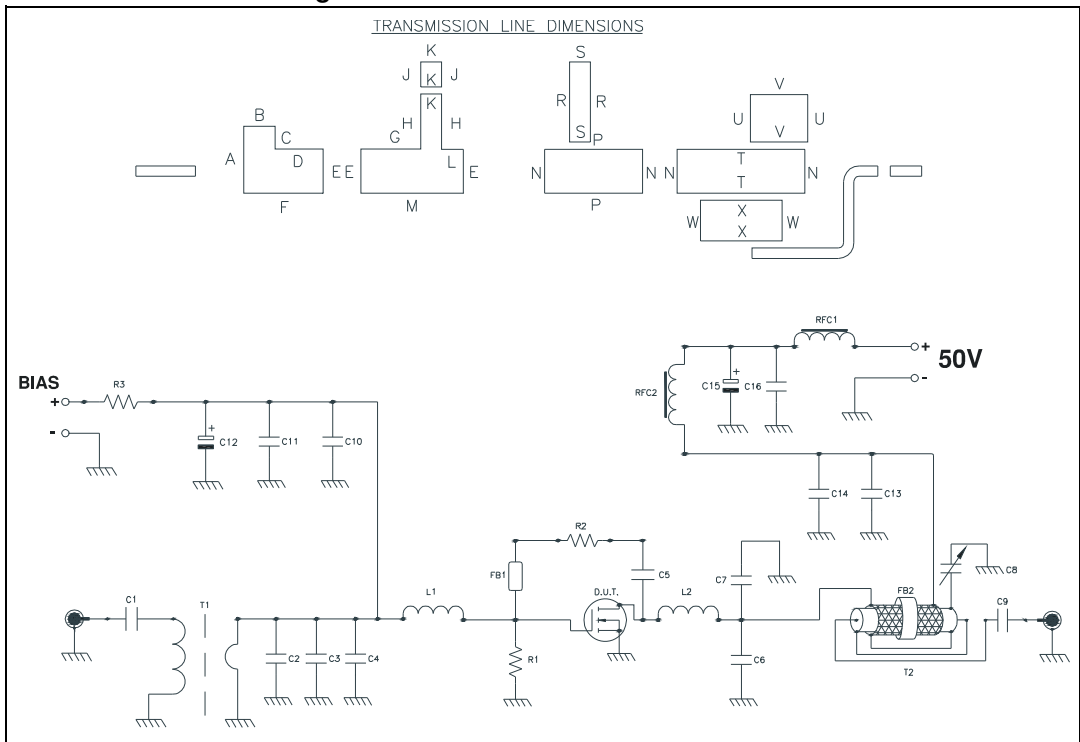

Table 7. Transmission line dimensions

Dim.	Inch	mm
A	0.532	13.51
B	0.250	6.35
C	0.181	4.59
D	0.383	9.37
E	0.351	8.91
F	0.633	16.08
G	0.477	12.12
H	0.438	11.12
J	0.200	5.08
K	0.164	4.16
L	0.174	4.42
M	0.817	20.75
N	0.350	8.89
P	0.779	19.79
R	0.639	16.23

Table 7. Transmission line dimensions (continued)

Dim.	Inch	mm
S	0.165	4.19
T	1.017	25.84
U	0.375	9.52
V	0.456	11.58
W	0.325	8.24
X	0.650	16.50

Table 8. 30 MHz test circuit component list

Component	Description
C1,C9	0.01 $\mu$ F / 500 V surface mount ceramic chip capacitor
C2, C3	750 pF ATC 700B surface mount ceramic chip capacitor
C4	300 pF ATC 700B surface mount ceramic chip capacitor
C5,C10,C11,C14,C16	10000 pF ATC 200B surface mount ceramic chip capacitor
C6	510 pF ATC 700B surface mount ceramic chip capacitor
C7	300 pF ATC 700B surface mount ceramic chip capacitor
C8	175-680 pF type 46 standard trimmer capacitor
C12	47 $\mu$ F / 63 V aluminum electrolytic radial lead capacitor
C13	1200 pF ATC 700B surface mount ceramic chip capacitor
C15	100 $\mu$ F / 63 V aluminum electrolytic radial lead capacitor
R1,R3	1 K OHM 1 W surface mount chip resistor
R2	560 OHM 2 W wire-wound axils lead resistor
T1	HF 2-30 MHz surface mount 9:1 transformer
T2	RG - 142B/U 50 OHM coaxial cable OD = 0.165[4.18] L 15"[381.00] covered with 15"[381.00] tinned copper tubular brand 13/65" [5.1] width
L1	1 3/4 turn air-wound 16 AWG ID = 0.219 [5.56] poly-coated magnet wire
L2	1 3/4 turn air-wound 12 AWG ID = 0.250 [6.34] bus bar wire
RFC1,RFC2	3 turns 14 AWG wire through ferrite toroid
FB1	Surface mount EMI shield bead
FB2	Toroid
PCB	ULTRALAM 2000. 0.030" THK, $\epsilon_r = 2.55$ , 2 Oz ED CU both sides

# 6 Circuit layout

Figure 13. Test fixture component layout

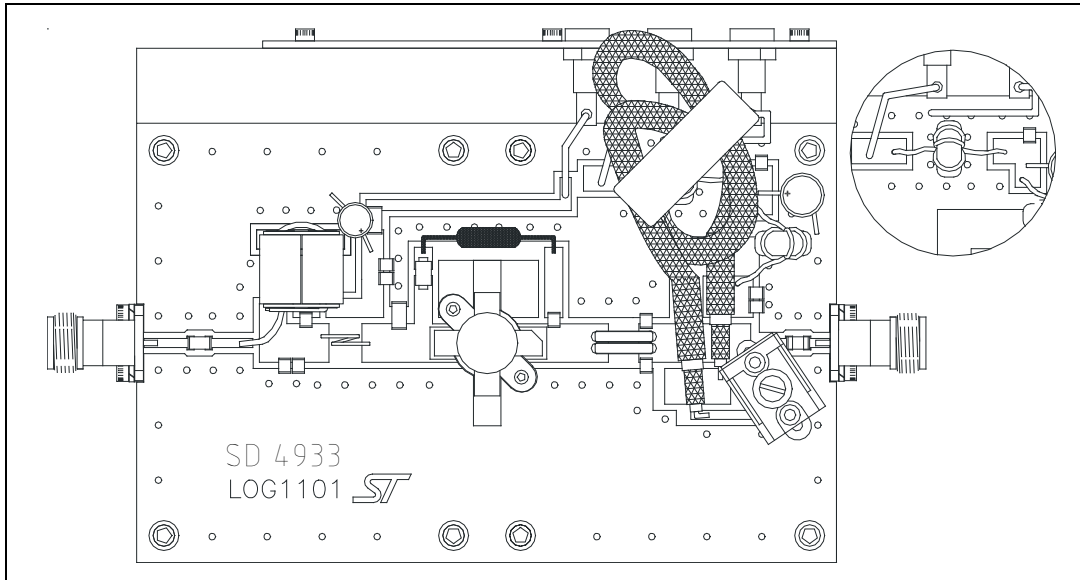
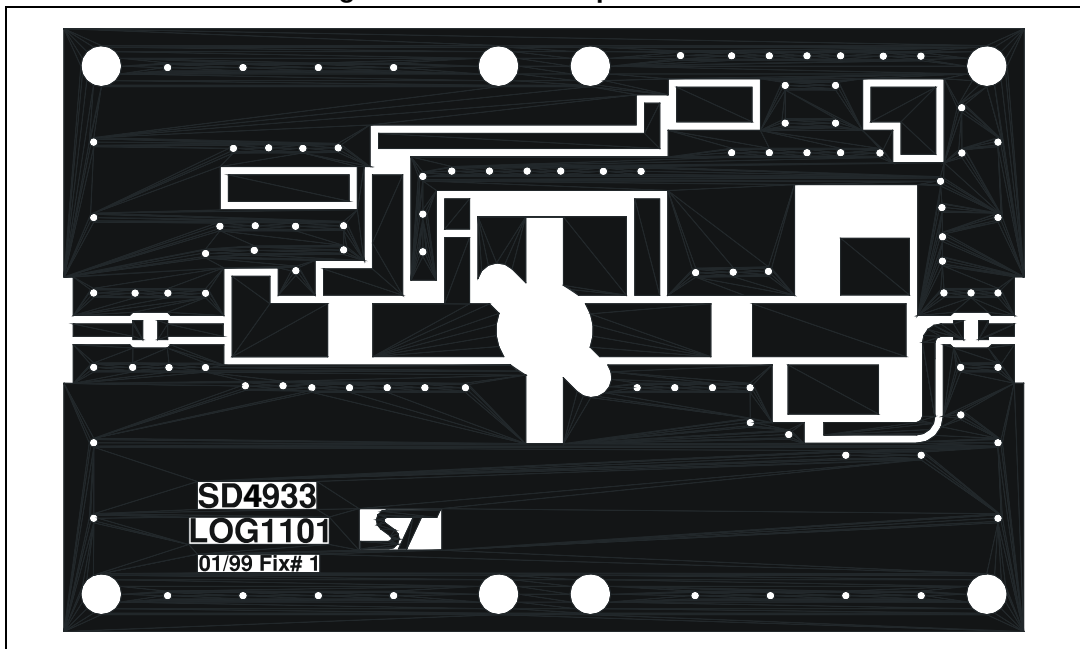

Figure 14. Test circuit photomasters



7 V<sub>GS</sub>/G<sub>FS</sub> sortsTable 9. V<sub>GS</sub>/G<sub>FS</sub> sorts

Marking	V <sub>GS</sub> (min)	V <sub>GS</sub> (max)	G <sub>FS</sub> (min)	G <sub>FS</sub> (max)
A1	1.50	1.75	5	6
A2	1.50	1.75	6	7
A3	1.50	1.75	7	8
A4	1.50	1.75	8	9
A5	1.50	1.75	9	10
A6	1.50	1.75	10	11
A7	1.50	1.75	11	12
A8	1.50	1.75	12	13
A9	1.50	1.75	13	14
B1	1.75	2.00	5	6
B2	1.75	2.00	6	7
B3	1.75	2.00	7	8
B4	1.75	2.00	8	9
B5	1.75	2.00	9	10
B6	1.75	2.00	10	11
B7	1.75	2.00	11	12
B8	1.75	2.00	12	13
B9	1.75	2.00	13	14
C1	2.00	2.25	5	6
C2	2.00	2.25	6	7
C3	2.00	2.25	7	8
C4	2.00	2.25	8	9
C5	2.00	2.25	9	10
C6	2.00	2.25	10	11
C7	2.00	2.25	11	12
C8	2.00	2.25	12	13
C9	2.00	2.25	13	14
D1	2.25	2.50	5	6
D2	2.25	2.50	6	7
D3	2.25	2.50	7	8
D4	2.25	2.50	8	9
D5	2.25	2.50	9	10

Table 9.  $V_{GS}/G_{FS}$  sorts (continued)

Marking	$V_{GS}(\text{min})$	$V_{GS}(\text{max})$	$G_{FS}(\text{min})$	$G_{FS}(\text{max})$
D6	2.25	2.50	10	11
D7	2.25	2.50	11	12
D8	2.25	2.50	12	13
D9	2.25	2.50	13	14
E1	2.50	2.75	5	6
E2	2.50	2.75	6	7
E3	2.50	2.75	7	8
E4	2.50	2.75	8	9
E5	2.50	2.75	9	10
E6	2.50	2.75	10	11
E7	2.50	2.75	11	12
E8	2.50	2.75	12	13
E9	2.50	2.75	13	14
F1	2.75	3.00	5	6
F2	2.75	3.00	6	7
F3	2.75	3.00	7	8
F4	2.75	3.00	8	9
F5	2.75	3.00	9	10
F6	2.75	3.00	10	11
F7	2.75	3.00	11	12
F8	2.75	3.00	12	13
F9	2.75	3.00	13	14
G1	3.00	3.25	5	6
G2	3.00	3.25	6	7
G3	3.00	3.25	7	8
G4	3.00	3.25	8	9
G5	3.00	3.25	9	10
G6	3.00	3.25	10	11
G7	3.00	3.25	11	12
G8	3.00	3.25	12	13
G9	3.00	3.25	13	14
H1	3.25	3.50	5	6
H2	3.25	3.50	6	7
H3	3.25	3.50	7	8
H4	3.25	3.50	8	9



Table 9. V<sub>GS</sub>/G<sub>FS</sub> sorts (continued)

Marking	V <sub>GS</sub> (min)	V <sub>GS</sub> (max)	G <sub>FS</sub> (min)	G <sub>FS</sub> (max)
H5	3.25	3.50	9	10
H6	3.25	3.50	10	11
H7	3.25	3.50	11	12
H8	3.25	3.50	12	13
H9	3.25	3.50	13	14
I1	3.50	3.75	5	6
I2	3.50	3.75	6	7
I3	3.50	3.75	7	8
I4	3.50	3.75	8	9
I5	3.50	3.75	9	10
I6	3.50	3.75	10	11
I7	3.50	3.75	11	12
I8	3.50	3.75	12	13
I9	3.50	3.75	13	14
J1	3.75	4.00	5	6
J2	3.75	4.00	6	7
J3	3.75	4.00	7	8
J4	3.75	4.00	8	9
J5	3.75	4.00	9	10
J6	3.75	4.00	10	11
J7	3.75	4.00	11	12
J8	3.75	4.00	12	13
J9	3.75	4.00	13	14

## 8 Marking, packing and shipping specifications

**Table 10. Packing and shipping specifications**

Order code	Packaging	Pcs per tray	Dry pack humidity	Vgs and Gfs code	Lot code
SD4933MR	Plastic tray	25	< 10 %	Not mixed	Not mixed

**Figure 15. Marking layout**

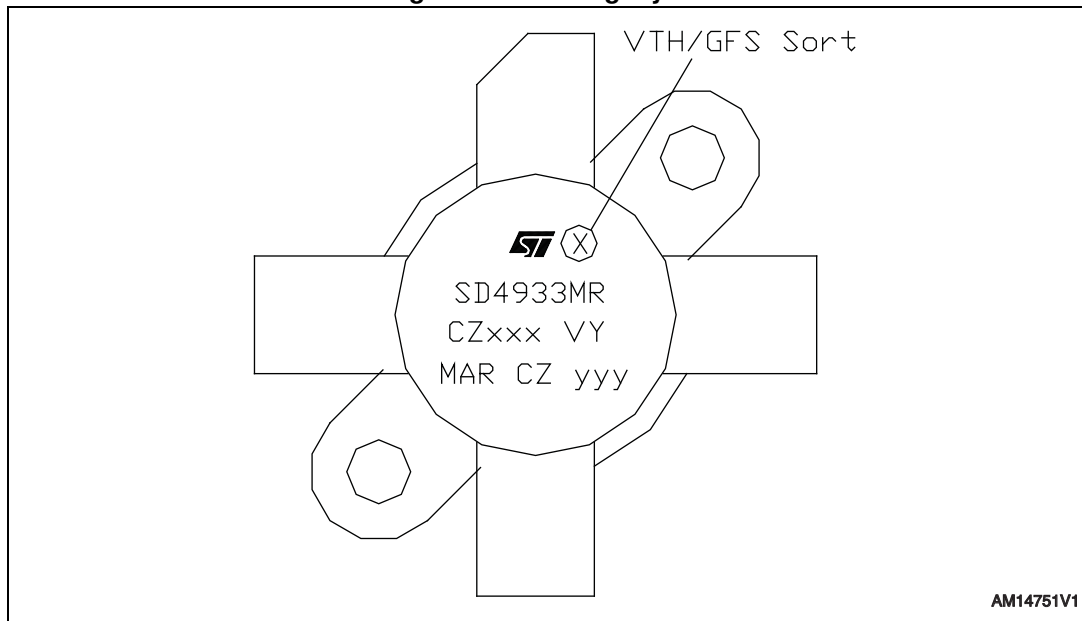

**Table 11. Marking specifications**

Symbol	Description
X	V <sub>GS</sub> and G <sub>FS</sub> sort
CZ	Assembly plant
xxx	Last 3 digits of diffusion lot
VY	Diffusion plant
MAR	Country of origin
CZ	Test and finishing plant
y	Assembly year
yy	Assembly week

## 9 Package mechanical data

In order to meet environmental requirements, ST offers these devices in different grades of ECOPACK® packages, depending on their level of environmental compliance. ECOPACK® specifications, grade definitions and product status are available at: [www.st.com](http://www.st.com). ECOPACK® is an ST trademark.

**Table 12. M177MR mechanical data**

Dim.	mm		
	Min.	Typ.	Max.
A	5.72		5.97
B	6.73		6.99
C	21.84		22.10
D	28.70		28.96
E	13.34		14.10
F	0.08		0.18
G	2.49		2.74
H	3.81		4.32
I			7.87
J	27.43		28.45
K	15.88		16.13

Figure 16. M177MR drawing

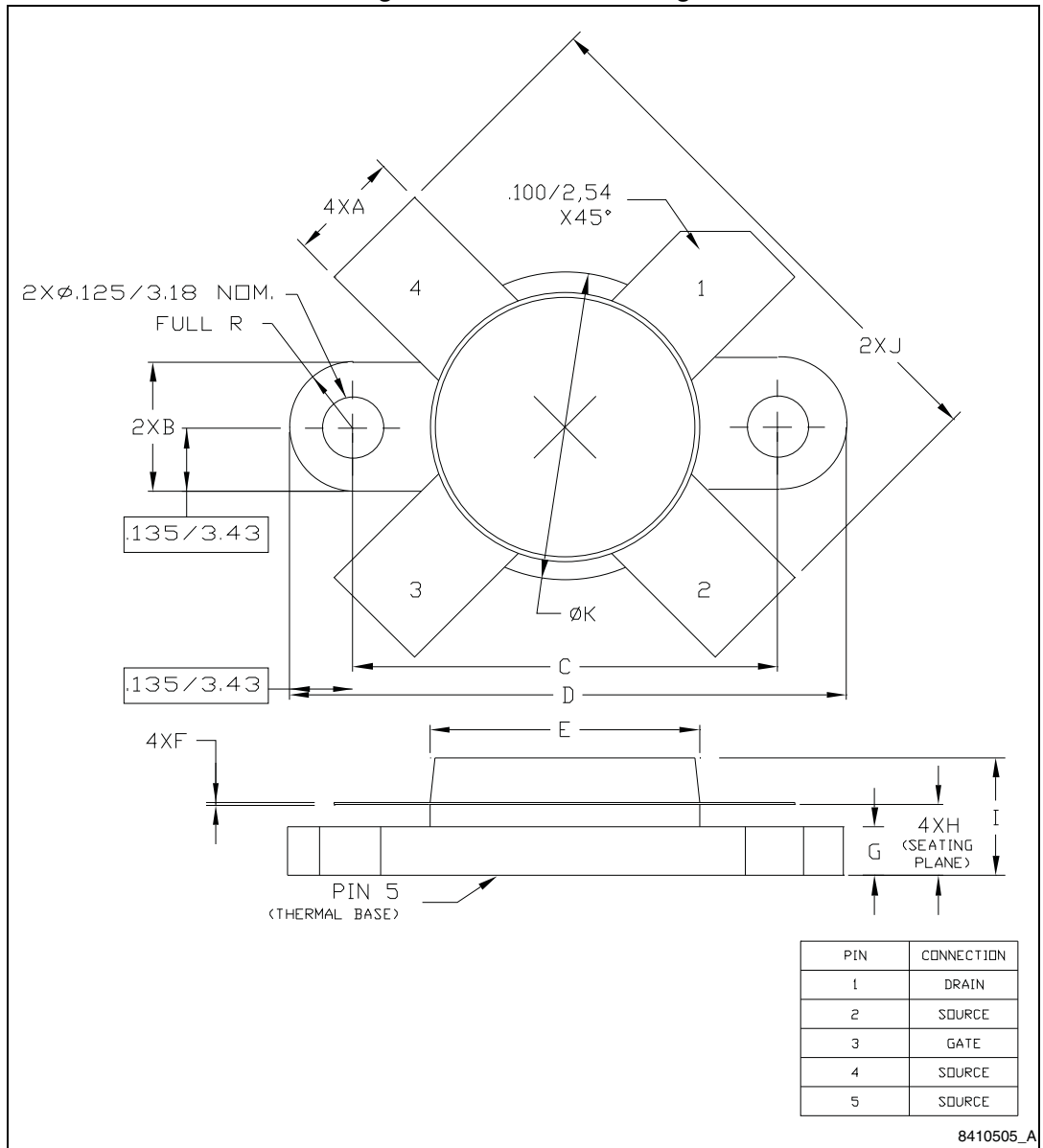

## 10 Revision history

**Table 13. Document revision history**

Date	Revision	Changes
13-Sep-2012	1	Initial release.
22-May-2013	2	Modified: I <sub>GSS</sub> value in <a href="#">Table 4: Static</a>

**Please Read Carefully:**

Information in this document is provided solely in connection with ST products. STMicroelectronics NV and its subsidiaries ("ST") reserve the right to make changes, corrections, modifications or improvements, to this document, and the products and services described herein at any time, without notice.

All ST products are sold pursuant to ST's terms and conditions of sale.

Purchasers are solely responsible for the choice, selection and use of the ST products and services described herein, and ST assumes no liability whatsoever relating to the choice, selection or use of the ST products and services described herein.

No license, express or implied, by estoppel or otherwise, to any intellectual property rights is granted under this document. If any part of this document refers to any third party products or services it shall not be deemed a license grant by ST for the use of such third party products or services, or any intellectual property contained therein or considered as a warranty covering the use in any manner whatsoever of such third party products or services or any intellectual property contained therein.

**UNLESS OTHERWISE SET FORTH IN ST'S TERMS AND CONDITIONS OF SALE ST DISCLAIMS ANY EXPRESS OR IMPLIED WARRANTY WITH RESPECT TO THE USE AND/OR SALE OF ST PRODUCTS INCLUDING WITHOUT LIMITATION IMPLIED WARRANTIES OF MERCHANTABILITY, FITNESS FOR A PARTICULAR PURPOSE (AND THEIR EQUIVALENTS UNDER THE LAWS OF ANY JURISDICTION), OR INFRINGEMENT OF ANY PATENT, COPYRIGHT OR OTHER INTELLECTUAL PROPERTY RIGHT.**

**ST PRODUCTS ARE NOT AUTHORIZED FOR USE IN WEAPONS. NOR ARE ST PRODUCTS DESIGNED OR AUTHORIZED FOR USE IN: (A) SAFETY CRITICAL APPLICATIONS SUCH AS LIFE SUPPORTING, ACTIVE IMPLANTED DEVICES OR SYSTEMS WITH PRODUCT FUNCTIONAL SAFETY REQUIREMENTS; (B) AERONAUTIC APPLICATIONS; (C) AUTOMOTIVE APPLICATIONS OR ENVIRONMENTS, AND/OR (D) AEROSPACE APPLICATIONS OR ENVIRONMENTS. WHERE ST PRODUCTS ARE NOT DESIGNED FOR SUCH USE, THE PURCHASER SHALL USE PRODUCTS AT PURCHASER'S SOLE RISK, EVEN IF ST HAS BEEN INFORMED IN WRITING OF SUCH USAGE, UNLESS A PRODUCT IS EXPRESSLY DESIGNATED BY ST AS BEING INTENDED FOR "AUTOMOTIVE, AUTOMOTIVE SAFETY OR MEDICAL" INDUSTRY DOMAINS ACCORDING TO ST PRODUCT DESIGN SPECIFICATIONS. PRODUCTS FORMALLY ESCC, QML OR JAN QUALIFIED ARE DEEMED SUITABLE FOR USE IN AEROSPACE BY THE CORRESPONDING GOVERNMENTAL AGENCY.**

Resale of ST products with provisions different from the statements and/or technical features set forth in this document shall immediately void any warranty granted by ST for the ST product or service described herein and shall not create or extend in any manner whatsoever, any liability of ST.

ST and the ST logo are trademarks or registered trademarks of ST in various countries.

Information in this document supersedes and replaces all information previously supplied.

The ST logo is a registered trademark of STMicroelectronics. All other names are the property of their respective owners.

© 2013 STMicroelectronics - All rights reserved

STMicroelectronics group of companies

Australia - Belgium - Brazil - Canada - China - Czech Republic - Finland - France - Germany - Hong Kong - India - Israel - Italy - Japan - Malaysia - Malta - Morocco - Philippines - Singapore - Spain - Sweden - Switzerland - United Kingdom - United States of America

[www.st.com](http://www.st.com)