



Chipsmall Limited consists of a professional team with an average of over 10 year of expertise in the distribution of electronic components. Based in Hongkong, we have already established firm and mutual-benefit business relationships with customers from,Europe,America and south Asia,supplying obsolete and hard-to-find components to meet their specific needs.

With the principle of “Quality Parts,Customers Priority,Honest Operation,and Considerate Service”,our business mainly focus on the distribution of electronic components. Line cards we deal with include Microchip,ALPS,ROHM,Xilinx,Pulse,ON,Everlight and Freescale. Main products comprise IC,Modules,Potentiometer,IC Socket,Relay,Connector.Our parts cover such applications as commercial,industrial, and automotives areas.

We are looking forward to setting up business relationship with you and hope to provide you with the best service and solution. Let us make a better world for our industry!



Contact us

Tel: +86-755-8981 8866 Fax: +86-755-8427 6832

Email & Skype: info@chipsmall.com Web: www.chipsmall.com

Address: A1208, Overseas Decoration Building, #122 Zhenhua RD., Futian, Shenzhen, China





InvenSense Inc.

1197 Borregas Ave, Sunnyvale, CA 94089 U.S.A.
Tel: +1 (408) 988-7339 Fax: +1 (408) 988-8104
Website: www.invensense.com

Document Number: PS-MPU-6000A-00
Revision: 3.1
Release Date: 10/24/2011

**MPU-6000 and MPU-6050
Product Specification
Revision 3.1**

ADVANCE INFORMATION



CONTENTS

1	REVISION HISTORY	5
2	PURPOSE AND SCOPE	6
3	PRODUCT OVERVIEW	7
3.1	MPU-60X0 OVERVIEW	7
4	APPLICATIONS	9
5	FEATURES	10
5.1	GYROSCOPE FEATURES	10
5.2	ACCELEROMETER FEATURES	10
5.3	ADDITIONAL FEATURES	10
5.4	MOTION PROCESSING	11
5.5	CLOCKING	11
6	ELECTRICAL CHARACTERISTICS	12
6.1	GYROSCOPE SPECIFICATIONS	12
6.2	ACCELEROMETER SPECIFICATIONS	13
6.3	ELECTRICAL AND OTHER COMMON SPECIFICATIONS	14
6.4	ELECTRICAL SPECIFICATIONS, CONTINUED	15
6.5	ELECTRICAL SPECIFICATIONS, CONTINUED	16
6.6	ELECTRICAL SPECIFICATIONS, CONTINUED	17
6.7	I ² C TIMING CHARACTERIZATION	18
6.8	SPI TIMING CHARACTERIZATION (MPU-6000 ONLY)	19
6.9	ABSOLUTE MAXIMUM RATINGS	20
7	APPLICATIONS INFORMATION	21
7.1	PIN OUT AND SIGNAL DESCRIPTION	21
7.2	TYPICAL OPERATING CIRCUIT	22
7.3	BILL OF MATERIALS FOR EXTERNAL COMPONENTS	22
7.4	RECOMMENDED POWER-ON PROCEDURE	23
7.5	BLOCK DIAGRAM	24
7.6	OVERVIEW	24
7.7	THREE-AXIS MEMS GYROSCOPE WITH 16-BIT ADCs AND SIGNAL CONDITIONING	25
7.8	THREE-AXIS MEMS ACCELEROMETER WITH 16-BIT ADCs AND SIGNAL CONDITIONING	25
7.9	DIGITAL MOTION PROCESSOR	25
7.10	PRIMARY I ² C AND SPI SERIAL COMMUNICATIONS INTERFACES	25
7.11	AUXILIARY I ² C SERIAL INTERFACE	26



7.12	SELF-TEST	27
7.13	MPU-60X0 SOLUTION FOR 9-AXIS SENSOR FUSION USING I ² C INTERFACE	28
7.14	MPU-6000 USING SPI INTERFACE	29
7.15	INTERNAL CLOCK GENERATION	30
7.16	SENSOR DATA REGISTERS	30
7.17	FIFO	30
7.18	INTERRUPTS	31
7.19	DIGITAL-OUTPUT TEMPERATURE SENSOR	31
7.20	BIAS AND LDO	31
7.21	CHARGE PUMP	31
8	PROGRAMMABLE INTERRUPTS.....	32
8.1	FREE FALL, MOTION, AND ZERO MOTION SIGNAL PATHS	33
8.2	FREE FALL INTERRUPT.....	34
8.3	MOTION INTERRUPT	34
8.4	ZERO MOTION INTERRUPT.....	35
9	DIGITAL INTERFACE	36
9.1	I ² C AND SPI (MPU-6000 ONLY) SERIAL INTERFACES	36
9.2	I ² C INTERFACE	36
9.3	I ² C COMMUNICATIONS PROTOCOL.....	36
9.4	I ² C TERMS	39
9.5	SPI INTERFACE (MPU-6000 ONLY)	40
10	SERIAL INTERFACE CONSIDERATIONS (MPU-6050).....	41
10.1	MPU-6050 SUPPORTED INTERFACES.....	41
10.2	LOGIC LEVELS	41
10.3	LOGIC LEVELS DIAGRAM FOR AUX_VDDIO = 0	42
10.4	LOGIC LEVELS DIAGRAM FOR AUX_VDDIO = 1	43
11	ASSEMBLY	44
11.1	ORIENTATION OF AXES	44
11.2	PACKAGE DIMENSIONS	45
11.3	PCB DESIGN GUIDELINES	46
11.4	ASSEMBLY PRECAUTIONS	47
11.5	STORAGE SPECIFICATIONS.....	51
11.6	PACKAGE MARKING SPECIFICATION.....	51
11.7	TAPE & REEL SPECIFICATION	52



11.8 LABEL53

11.9 PACKAGING54

12 RELIABILITY55

12.1 QUALIFICATION TEST POLICY55

12.2 QUALIFICATION TEST PLAN55

13 ENVIRONMENTAL COMPLIANCE.....56

ADVANCE INFORMATION



1 Revision History

Revision Date	Revision	Description
11/24/2010	1.0	Initial Release
05/19/2011	2.0	For Rev C parts. Clarified wording in sections (3.2, 5.1, 5.2, 6.1-6.4, 6.6, 6.9, 7, 7.1-7.6, 7.11, 7.12, 7.14, 8, 8.2-8.4, 10.3, 10.4, 11, 12.2)
07/28/2011	2.1	Edited supply current numbers for different modes (section 6.4)
08/05/2011	2.2	Unit of measure for accelerometer sensitivity changed from LSB/mg to LSB/g
10/12/2011	2.3	Updated accelerometer self test specifications in Table 6.2. Updated package dimensions (section 11.2). Updated PCB design guidelines (section 11.3)
10/18/2011	3.0	For Rev D parts. Updated accelerometer specifications in Table 6.2. Updated accelerometer specification note (sections 8.2, 8.3, & 8.4). Updated qualification test plan (section 12.2).
10/24/2011	3.1	Edits for clarity Changed operating voltage range to 2.375V-3.46V Added accelerometer Intelligence Function increment value of 1mg/LSB (Section 6.2) Updated absolute maximum rating for acceleration (any axis, unpowered) from 0.3ms to 0.2ms (Section 6.9) Modified absolute maximum rating for Latch-up to Level A and $\pm 100\text{mA}$ (Section 6.9, 12.2)



2 Purpose and Scope

This product specification provides advanced information regarding the electrical specification and design related information for the MPU-6000™ and MPU-6050™ Motion Processing Unit™, collectively called the MPU-60X0™ or MPU™.

Electrical characteristics are based upon design analysis and simulation results only. Specifications are subject to change without notice. Final specifications will be updated based upon characterization of production silicon. For references to register map and descriptions of individual registers, please refer to the MPU-6000/MPU-6050 Register Map and Register Descriptions document.

ADVANCE INFORMATION

3 Product Overview

3.1 MPU-60X0 Overview

The MPU-60X0 Motion Processing Unit is the world's first motion processing solution with integrated 9-Axis sensor fusion using its field-proven and proprietary MotionFusion™ engine for handset and tablet applications, game controllers, motion pointer remote controls, and other consumer devices. The MPU-60X0 has an embedded 3-axis MEMS gyroscope, a 3-axis MEMS accelerometer, and a Digital Motion Processor™ (DMP™) hardware accelerator engine with an auxiliary I²C port that interfaces to 3rd party digital sensors such as magnetometers. When connected to a 3-axis magnetometer, the MPU-60X0 delivers a complete 9-axis MotionFusion output to its primary I²C or SPI port (SPI is available on MPU-6000 only). The MPU-60X0 combines acceleration and rotational motion plus heading information into a single data stream for the application. This MotionProcessing™ technology integration provides a smaller footprint and has inherent cost advantages compared to discrete gyroscope plus accelerometer solutions. The MPU-60X0 is also designed to interface with multiple non-inertial digital sensors, such as pressure sensors, on its auxiliary I²C port. The MPU-60X0 is a 2nd generation motion processor and is footprint compatible with the MPU-30X0 family.

The MPU-60X0 features three 16-bit analog-to-digital converters (ADCs) for digitizing the gyroscope outputs and three 16-bit ADCs for digitizing the accelerometer outputs. For precision tracking of both fast and slow motions, the parts feature a user-programmable gyroscope full-scale range of ± 250 , ± 500 , ± 1000 , and $\pm 2000^\circ/\text{sec}$ (dps) and a user-programmable accelerometer full-scale range of $\pm 2g$, $\pm 4g$, $\pm 8g$, and $\pm 16g$.

An on-chip 1024 Byte FIFO buffer helps lower system power consumption by allowing the system processor to read the sensor data in bursts and then enter a low-power mode as the MPU collects more data. With all the necessary on-chip processing and sensor components required to support many motion-based use cases, the MPU-60X0 uniquely supports a variety of advanced motion-based applications entirely on-chip. The MPU-60X0 thus enables low-power MotionProcessing in portable applications with reduced processing requirements for the system processor. By providing an integrated MotionFusion output, the DMP in the MPU-60X0 offloads the intensive MotionProcessing computation requirements from the system processor, minimizing the need for frequent polling of the motion sensor output.

Communication with all registers of the device is performed using either I²C at 400kHz or SPI at 1MHz (MPU-6000 only). For applications requiring faster communications, the sensor and interrupt registers may be read using SPI at 20MHz (MPU-6000 only). Additional features include an embedded temperature sensor and an on-chip oscillator with $\pm 1\%$ variation over the operating temperature range.

By leveraging its patented and volume-proven Nasiri-Fabrication platform, which integrates MEMS wafers with companion CMOS electronics through wafer-level bonding, InvenSense has driven the MPU-60X0 package size down to a revolutionary footprint of 4x4x0.9mm (QFN), while providing the highest performance, lowest noise, and the lowest cost semiconductor packaging required for handheld consumer electronic devices. The part features a robust 10,000g shock tolerance, and has programmable low-pass filters for the gyroscopes, accelerometers, and the on-chip temperature sensor.

For power supply flexibility, the MPU-60X0 operates from VDD power supply voltage range of 2.375V-3.46V. Additionally, the MPU-6050 provides a VLOGIC reference pin (in addition to its analog supply pin: VDD), which sets the logic levels of its I²C interface. The VLOGIC voltage may be $1.8V \pm 5\%$ or VDD.

The MPU-6000 and MPU-6050 are identical, except that the MPU-6050 supports the I²C serial interface only, and has a separate VLOGIC reference pin. The MPU-6000 supports both I²C and SPI interfaces and has a single supply pin, VDD, which is both the device's logic reference supply and the analog supply for the part. The table below outlines these differences:



Primary Differences between MPU-6000 and MPU-6050

Part / Item	MPU-6000	MPU-6050
VDD	2.375V-3.46V	2.375V-3.46V
VLOGIC	n/a	1.71V to VDD
Serial Interfaces Supported	I ² C, SPI	I ² C
Pin 8	/CS	VLOGIC
Pin 9	AD0/SDO	AD0
Pin 23	SCL/SCLK	SCL
Pin 24	SDA/SDI	SDA

ADVANCE INFORMATION



4 Applications

- *BlurFree*[™] technology (for Video/Still Image Stabilization)
- *AirSign*[™] technology (for Security/Authentication)
- *TouchAnywhere*[™] technology (for “no touch” UI Application Control/Navigation)
- *MotionCommand*[™] technology (for Gesture Short-cuts)
- Motion-enabled game and application framework
- InstantGesture[™] iG[™] gesture recognition
- Location based services, points of interest, and dead reckoning
- Handset and portable gaming
- Motion-based game controllers
- 3D remote controls for Internet connected DTVs and set top boxes, 3D mice
- Wearable sensors for health, fitness and sports
- Toys

ADVANCE INFORMATION

5 Features

5.1 Gyroscope Features

The triple-axis MEMS gyroscope in the MPU-60X0 includes a wide range of features:

- Digital-output X-, Y-, and Z-Axis angular rate sensors (gyroscopes) with a user-programmable full-scale range of ± 250 , ± 500 , ± 1000 , and $\pm 2000^\circ/\text{sec}$
- External sync signal connected to the FSYNC pin supports image, video and GPS synchronization
- Integrated 16-bit ADCs enable simultaneous sampling of gyros
- Enhanced bias and sensitivity temperature stability reduces the need for user calibration
- Improved low-frequency noise performance
- Digitally-programmable low-pass filter
- Gyroscope operating current: 3.6mA
- Standby current: 5 μ A
- Factory calibrated sensitivity scale factor

5.2 Accelerometer Features

The triple-axis MEMS accelerometer in MPU-60X0 includes a wide range of features:

- Digital-output triple-axis accelerometer with a programmable full scale range of $\pm 2g$, $\pm 4g$, $\pm 8g$ and $\pm 16g$
- Integrated 16-bit ADCs enable simultaneous sampling of accelerometers while requiring no external multiplexer
- Accelerometer normal operating current: 500 μ A
- Low power accelerometer mode current: 10 μ A at 1.25Hz, 20 μ A at 5Hz, 60 μ A at 20Hz, 110 μ A at 40Hz
- Orientation detection and signaling
- Tap detection
- User-programmable interrupts
- Free-fall interrupt
- High-G interrupt
- Zero Motion/Motion interrupt
- User self-test

5.3 Additional Features

The MPU-60X0 includes the following additional features:

- 9-Axis MotionFusion by the on-chip Digital Motion Processor (DMP)
- Auxiliary master I²C bus for reading data from external sensors (e.g., magnetometer)
- 3.9mA operating current when all 6 motion sensing axes and the DMP are enabled
- VDD supply voltage range of 2.375V-3.46V
- Flexible VLOGIC reference voltage supports multiple I²C interface voltages (MPU-6050 only)
- Smallest and thinnest QFN package for portable devices: 4x4x0.9mm
- Minimal cross-axis sensitivity between the accelerometer and gyroscope axes
- 1024 byte FIFO buffer reduces power consumption by allowing host processor to read the data in bursts and then go into a low-power mode as the MPU collects more data
- Digital-output temperature sensor
- User-programmable digital filters for gyroscope, accelerometer, and temp sensor
- 10,000 g shock tolerant
- 400kHz Fast Mode I²C for communicating with all registers
- 1MHz SPI serial interface for communicating with all registers (MPU-6000 only)

- 20MHz SPI serial interface for reading sensor and interrupt registers (MPU-6000 only)
- MEMS structure hermetically sealed and bonded at wafer level
- RoHS and Green compliant

5.4 MotionProcessing

- Internal Digital Motion Processing™ (DMP™) engine supports 3D MotionProcessing and gesture recognition algorithms
- The MPU-60X0 collects gyroscope and accelerometer data while synchronizing data sampling at a user defined rate. The total dataset obtained by the MPU-60X0 includes 3-Axis gyroscope data, 3-Axis accelerometer data, and temperature data. The MPU's calculated output to the system processor can also include heading data from a digital 3-axis third party magnetometer.
- The FIFO buffers the complete data set, reducing timing requirements on the system processor by allowing the processor burst read the FIFO data. After burst reading the FIFO data, the system processor can save power by entering a low-power sleep mode while the MPU collects more data.
- Programmable interrupt supports features such as gesture recognition, panning, zooming, scrolling, zero-motion detection, tap detection, and shake detection
- Digitally-programmable low-pass filters
- Low-power pedometer functionality allows the host processor to sleep while the DMP maintains the step count.

5.5 Clocking

- On-chip timing generator $\pm 1\%$ frequency variation over full temperature range
- Optional external clock inputs of 32.768kHz or 19.2MHz



6 Electrical Characteristics

6.1 Gyroscope Specifications

VDD = 2.375V-3.46V, VLOGIC (MPU-6050 only) = 1.8V±5% or VDD, T_A = 25°C

PARAMETER	CONDITIONS	MIN	TYP	MAX	UNITS	NOTES
GYROSCOPE SENSITIVITY						
Full-Scale Range	FS_SEL=0		±250		°/s	
	FS_SEL=1		±500		°/s	
	FS_SEL=2		±1000		°/s	
	FS_SEL=3		±2000		°/s	
Gyroscope ADC Word Length			16		bits	
Sensitivity Scale Factor	FS_SEL=0		131		LSB/(°/s)	
	FS_SEL=1		65.5		LSB/(°/s)	
	FS_SEL=2		32.8		LSB/(°/s)	
	FS_SEL=3		16.4		LSB/(°/s)	
Sensitivity Scale Factor Tolerance	25°C	-3		+3	%	
Sensitivity Scale Factor Variation Over Temperature			±2		%	
Nonlinearity	Best fit straight line; 25°C		0.2		%	
Cross-Axis Sensitivity			±2		%	
GYROSCOPE ZERO-RATE OUTPUT (ZRO)						
Initial ZRO Tolerance	25°C		±20		°/s	
ZRO Variation Over Temperature	-40°C to +85°C		±20		°/s	
Power-Supply Sensitivity (1-10Hz)	Sine wave, 100mVpp; VDD=2.5V		0.2		°/s	
Power-Supply Sensitivity (10 - 250Hz)	Sine wave, 100mVpp; VDD=2.5V		0.2		°/s	
Power-Supply Sensitivity (250Hz - 100kHz)	Sine wave, 100mVpp; VDD=2.5V		4		°/s	
Linear Acceleration Sensitivity	Static		0.1		°/s/g	
GYROSCOPE NOISE PERFORMANCE	FS_SEL=0					
Total RMS Noise	DLPCFG=2 (100Hz)		0.05		°/s-rms	
Low-frequency RMS noise	Bandwidth 1Hz to 10Hz		0.033		°/s-rms	
Rate Noise Spectral Density	At 10Hz		0.005		°/s/√Hz	
GYROSCOPE MECHANICAL FREQUENCIES						
X-Axis		30	33	36	kHz	
Y-Axis		27	30	33	kHz	
Z-Axis		24	27	30	kHz	
LOW PASS FILTER RESPONSE						
	Programmable Range	5		256	Hz	
OUTPUT DATA RATE						
	Programmable	4		8,000	Hz	
GYROSCOPE START-UP TIME						
ZRO Settling	DLPCFG=0 to ±1°/s of Final		30		ms	



6.2 Accelerometer Specifications

VDD = 2.375V-3.46V, VLOGIC (MPU-6050 only) = 1.8V±5% or VDD, T_A = 25°C

PARAMETER	CONDITIONS	MIN	TYP	MAX	UNITS	NOTES
ACCELEROMETER SENSITIVITY						
Full-Scale Range	AFS_SEL=0		±2		g	
	AFS_SEL=1		±4		g	
	AFS_SEL=2		±8		g	
	AFS_SEL=3		±16		g	
ADC Word Length	Output in two's complement format		16		bits	
Sensitivity Scale Factor	AFS_SEL=0		16,384		LSB/g	
	AFS_SEL=1		8,192		LSB/g	
	AFS_SEL=2		4,096		LSB/g	
	AFS_SEL=3		2,048		LSB/g	
Initial Calibration Tolerance			±3		%	
Sensitivity Change vs. Temperature	AFS_SEL=0, -40°C to +85°C		±0.02		%/°C	
Nonlinearity	Best Fit Straight Line		0.5		%	
Cross-Axis Sensitivity			±2		%	
ZERO-G OUTPUT						
Initial Calibration Tolerance ¹	X and Y axes		±50		mg	
	Z axis		±80		mg	
Zero-G Level Change vs. Temperature	X and Y axes, 0°C to +70°C		±35			
	Z axis, 0°C to +70°C		±60		mg	
SELF TEST RESPONSE						
			0.5		g	
NOISE PERFORMANCE						
Power Spectral Density	@10Hz, AFS_SEL=0 & ODR=1kHz		400		μg/√Hz	
LOW PASS FILTER RESPONSE						
	Programmable Range	5		260	Hz	
OUTPUT DATA RATE						
	Programmable Range	4		1,000	Hz	
INTELLIGENCE FUNCTION INCREMENT						
			1		mg/LSB	

1. Typical zero-g initial calibration tolerance value after MSL3 preconditioning



6.3 Electrical and Other Common Specifications

VDD = 2.375V-3.46V, VLOGIC (MPU-6050 only) = 1.8V±5% or VDD, T_A = 25°C

PARAMETER	CONDITIONS	MIN	TYP	MAX	Units	Notes
TEMPERATURE SENSOR						
Range			-40 to +85		°C	
Sensitivity	Untrimmed		340		LSB/°C	
Temperature Offset	35°C		-521		LSB	
Linearity	Best fit straight line (-40°C to +85°C)		±1		°C	
VDD POWER SUPPLY						
Operating Voltages		2.375		3.46	V	
Normal Operating Current	Gyroscope + Accelerometer + DMP		3.9		mA	
	Gyroscope + Accelerometer (DMP disabled)		3.8		mA	
	Gyroscope + DMP (Accelerometer disabled)		3.7		mA	
	Gyroscope only (DMP & Accelerometer disabled)		3.6		mA	
	Accelerometer only (DMP & Gyroscope disabled)		500		µA	
Accelerometer Low Power Mode Current	1.25 Hz update rate		10		µA	
	5 Hz update rate		20		µA	
	20 Hz update rate		60		µA	
	40 Hz update rate		110		µA	
Full-Chip Idle Mode Supply Current			5		µA	
Power Supply Ramp Rate	Monotonic ramp. Ramp rate is 10% to 90% of the final value			100	ms	
VLOGIC REFERENCE VOLTAGE						
Voltage Range	MPU-6050 only VLOGIC must be ≤VDD at all times	1.71		VDD	V	
Power Supply Ramp Rate	Monotonic ramp. Ramp rate is 10% to 90% of the final value			3	ms	
Normal Operating Current			100		µA	
START-UP TIME FOR REGISTER READ/WRITE						
			20	100	ms	
TEMPERATURE RANGE						
Specified Temperature Range	Performance parameters are not applicable beyond Specified Temperature Range	-40		+85	°C	



6.4 Electrical Specifications, Continued

VDD = 2.375V-3.46V, VLOGIC (MPU-6050 only) = 1.8V±5% or VDD, TA = 25°C

PARAMETER	CONDITIONS	MIN	TYP	MAX	Units	Notes
SERIAL INTERFACE						
SPI Operating Frequency, All Registers Read/Write	MPU-6000 only, Low Speed Characterization		100 ±10%		kHz	
	MPU-6000 only, High Speed Characterization		1 ±10%		MHz	
SPI Operating Frequency, Sensor and Interrupt Registers Read Only	MPU-6000 only		20 ±10%		MHz	
	All registers, Fast-mode			400	kHz	
I ² C Operating Frequency	All registers, Standard-mode			100	kHz	
I²C ADDRESS						
	AD0 = 0		1101000			
	AD0 = 1		1101001			
DIGITAL INPUTS (SDI/SDA, AD0, SCLK/SCL, FSYNC, /CS, CLKIN)						
V _{IH} , High Level Input Voltage	MPU-6000	0.7*VDD			V	
	MPU-6050	0.7*VLOGIC			V	
V _{IL} , Low Level Input Voltage	MPU-6000			0.3*VDD	V	
	MPU-6050			0.3*VLOGIC	V	
C _i , Input Capacitance			< 5		pF	
DIGITAL OUTPUT (SDO, INT)						
V _{OH} , High Level Output Voltage	R _{LOAD} =1MΩ; MPU-6000	0.9*VDD			V	
	R _{LOAD} =1MΩ; MPU-6050	0.9*VLOGIC			V	
V _{OL1} , LOW-Level Output Voltage	R _{LOAD} =1MΩ; MPU-6000			0.1*VDD	V	
	R _{LOAD} =1MΩ; MPU-6050			0.1*VLOGIC	V	
V _{OL,INT1} , INT Low-Level Output Voltage	OPEN=1, 0.3mA sink Current			0.1	V	
Output Leakage Current	OPEN=1		100		nA	
t _{INT} , INT Pulse Width	LATCH_INT_EN=0		50		μs	
DIGITAL OUTPUT (CLKOUT)						
V _{OH} , High Level Output Voltage	R _{LOAD} =1MΩ	0.9*VDD			V	
V _{OL1} , LOW-Level Output Voltage	R _{LOAD} =1MΩ			0.1*VDD	V	



6.5 Electrical Specifications, Continued

Typical Operating Circuit of Section 7.2, VDD = 2.375V-3.46V, VLOGIC (MPU-6050 only) = 1.8V±5% or VDD, TA = 25°C

Parameters	Conditions	Typical	Units	Notes
Primary I²C I/O (SCL, SDA)				
V _{IL} , LOW-Level Input Voltage	MPU-6000	-0.5 to 0.3*VDD	V	
V _{IH} , HIGH-Level Input Voltage	MPU-6000	0.7*VDD to VDD + 0.5V	V	
V _{hys} , Hysteresis	MPU-6000	0.1*VDD	V	
V _{IL} , LOW Level Input Voltage	MPU-6050	-0.5V to 0.3*VLOGIC	V	
V _{IH} , HIGH-Level Input Voltage	MPU-6050	0.7*VLOGIC to VLOGIC + 0.5V	V	
V _{hys} , Hysteresis	MPU-6050	0.1*VLOGIC	V	
V _{OL1} , LOW-Level Output Voltage	3mA sink current	0 to 0.4	V	
I _{OL} , LOW-Level Output Current	V _{OL} = 0.4V	3	mA	
	V _{OL} = 0.6V	5	mA	
Output Leakage Current		100	nA	
t _{of} , Output Fall Time from V _{IHmax} to V _{ILmax}	C _b bus capacitance in pF	20+0.1C _b to 250	ns	
C _I , Capacitance for Each I/O pin		< 10	pF	
Auxiliary I²C I/O (AUX_CL, AUX_DA)				
MPU-6050: AUX_VDDIO=0				
V _{IL} , LOW-Level Input Voltage		-0.5V to 0.3*VLOGIC	V	
V _{IH} , HIGH-Level Input Voltage		0.7*VLOGIC to VLOGIC + 0.5V	V	
V _{hys} , Hysteresis		0.1*VLOGIC	V	
V _{OL1} , LOW-Level Output Voltage	VLOGIC > 2V; 1mA sink current	0 to 0.4	V	
V _{OL3} , LOW-Level Output Voltage	VLOGIC < 2V; 1mA sink current	0 to 0.2*VLOGIC	V	
I _{OL} , LOW-Level Output Current	V _{OL} = 0.4V	1	mA	
	V _{OL} = 0.6V	1	mA	
Output Leakage Current		100	nA	
t _{of} , Output Fall Time from V _{IHmax} to V _{ILmax}	C _b bus capacitance in pF	20+0.1C _b to 250	ns	
C _I , Capacitance for Each I/O pin		< 10	pF	
Auxiliary I²C I/O (AUX_CL, AUX_DA)				
MPU-6050: AUX_VDDIO=1; MPU-6000				
V _{IL} , LOW-Level Input Voltage		-0.5 to 0.3*VDD	V	
V _{IH} , HIGH-Level Input Voltage		0.7*VDD to VDD+0.5V	V	
V _{hys} , Hysteresis		0.1*VDD	V	
V _{OL1} , LOW-Level Output Voltage	1mA sink current	0 to 0.4	V	
I _{OL} , LOW-Level Output Current	V _{OL} = 0.4V	1	mA	
	V _{OL} = 0.6V	1	mA	
Output Leakage Current		100	nA	
t _{of} , Output Fall Time from V _{IHmax} to V _{ILmax}	C _b bus cap. in pF	20+0.1C _b to 250	ns	
C _I , Capacitance for Each I/O pin		< 10	pF	



6.6 Electrical Specifications, Continued

Typical Operating Circuit of Section 7.2, VDD = 2.375V-3.46V, VLOGIC (MPU-6050 only) = 1.8V±5% or VDD, TA = 25°C

Parameters	Conditions	Min	Typical	Max	Units	Notes
INTERNAL CLOCK SOURCE	CLK_SEL=0,1,2,3					
Gyroscope Sample Rate, Fast	DLPFCFG=0 SAMPLERATEDIV = 0		8		kHz	
Gyroscope Sample Rate, Slow	DLPFCFG=1,2,3,4,5, or 6 SAMPLERATEDIV = 0		1		kHz	
Accelerometer Sample Rate			1		kHz	
Reference Clock Output	CLKOUTEN = 1		1.024		MHz	
Clock Frequency Initial Tolerance	CLK_SEL=0, 25°C	-5		+5	%	
	CLK_SEL=1,2,3; 25°C	-1		+1	%	
Frequency Variation over Temperature	CLK_SEL=0		-15 to +10		%	
	CLK_SEL=1,2,3		±1		%	
PLL Settling Time	CLK_SEL=1,2,3		1	10	ms	
EXTERNAL 32.768kHz CLOCK	CLK_SEL=4					
External Clock Frequency			32.768		kHz	
External Clock Allowable Jitter	Cycle-to-cycle rms		1 to 2		µs	
Gyroscope Sample Rate, Fast	DLPFCFG=0 SAMPLERATEDIV = 0		8.192		kHz	
Gyroscope Sample Rate, Slow	DLPFCFG=1,2,3,4,5, or 6 SAMPLERATEDIV = 0		1.024		kHz	
Accelerometer Sample Rate			1.024		kHz	
Reference Clock Output	CLKOUTEN = 1		1.0486		MHz	
PLL Settling Time			1	10	ms	
EXTERNAL 19.2MHz CLOCK	CLK_SEL=5					
External Clock Frequency			19.2		MHz	
Gyroscope Sample Rate	Full programmable range	3.9		8000	Hz	
Gyroscope Sample Rate, Fast Mode	DLPFCFG=0 SAMPLERATEDIV = 0		8		kHz	
Gyroscope Sample Rate, Slow Mode	DLPFCFG=1,2,3,4,5, or 6 SAMPLERATEDIV = 0		1		kHz	
Accelerometer Sample Rate			1		kHz	
Reference Clock Output	CLKOUTEN = 1		1.024		MHz	
PLL Settling Time			1	10	ms	

6.7 I²C Timing Characterization

Typical Operating Circuit of Section 7.2, VDD = 2.375V-3.46V, VLOGIC (MPU-6050 only) = 1.8V±5% or VDD, T_A = 25°C

Parameters	Conditions	Min	Typical	Max	Units	Notes
I²C TIMING						
f _{SCL} , SCL Clock Frequency	I ² C FAST-MODE			400	kHz	
t _{HD,STA} , (Repeated) START Condition Hold Time		0.6			μs	
t _{LOW} , SCL Low Period		1.3			μs	
t _{HIGH} , SCL High Period		0.6			μs	
t _{SU,STA} , Repeated START Condition Setup Time		0.6			μs	
t _{HD,DAT} , SDA Data Hold Time		0			μs	
t _{SU,DAT} , SDA Data Setup Time		100			ns	
t _r , SDA and SCL Rise Time	C _b bus cap. from 10 to 400pF	20+0.1C _b		300	ns	
t _f , SDA and SCL Fall Time	C _b bus cap. from 10 to 400pF	20+0.1C _b		300	ns	
t _{SU,STO} , STOP Condition Setup Time		0.6			μs	
t _{BUF} , Bus Free Time Between STOP and START Condition		1.3			μs	
C _b , Capacitive Load for each Bus Line			< 400		pF	
t _{VD,DAT} , Data Valid Time				0.9	μs	
t _{VD,ACK} , Data Valid Acknowledge Time				0.9	μs	

Note: Timing Characteristics apply to both Primary and Auxiliary I²C Bus

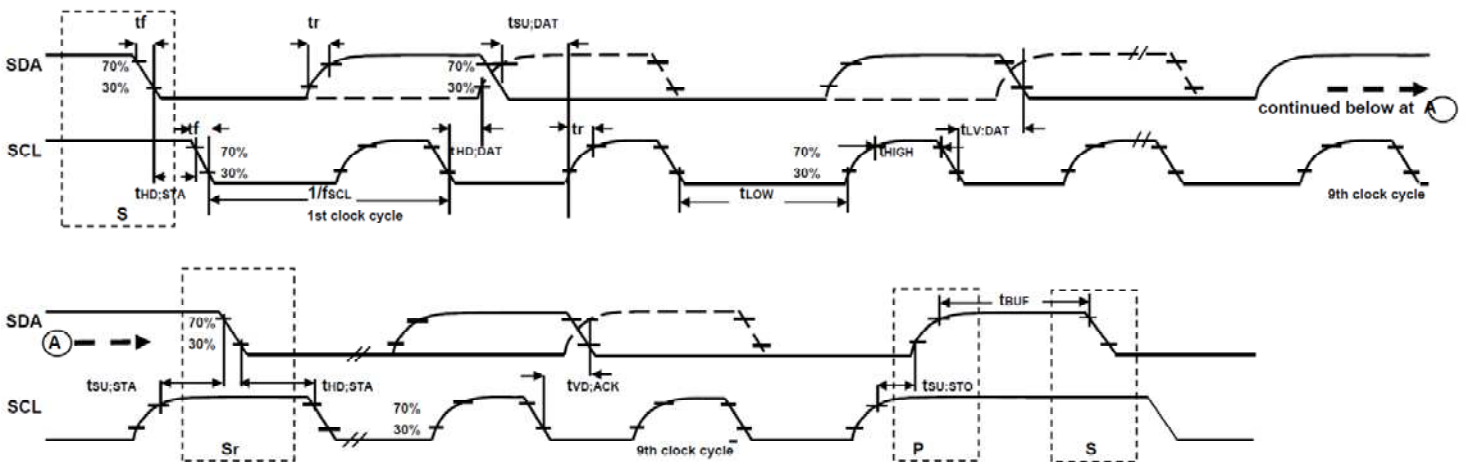

I²C Bus Timing Diagram

6.8 SPI Timing Characterization (MPU-6000 only)

 Typical Operating Circuit of Section 7.2, VDD = 2.375V-3.46V, VLOGIC (MPU-6050 only) = 1.8V±5% or VDD, T_A = -40°C to +85°C, unless otherwise noted.

Parameters	Conditions	Min	Typical	Max	Units	Notes
SPI TIMING						
f _{SCLK} , SCLK Clock Frequency				1	MHz	
t _{LOW} , SCLK Low Period		400			ns	
t _{HIGH} , SCLK High Period		400			ns	
t _{SU,CS} , CS Setup Time		8			ns	
t _{HD,CS} , CS Hold Time		500			ns	
t _{SU,SDI} , SDI Setup Time		11			ns	
t _{HD,SDI} , SDI Hold Time		7			ns	
t _{VD,SDO} , SDO Valid Time	C _{load} = 20pF			100	ns	
t _{HD,SDO} , SDO Hold Time	C _{load} = 20pF	4			ns	
t _{DIS,SDO} , SDO Output Disable Time				10	ns	

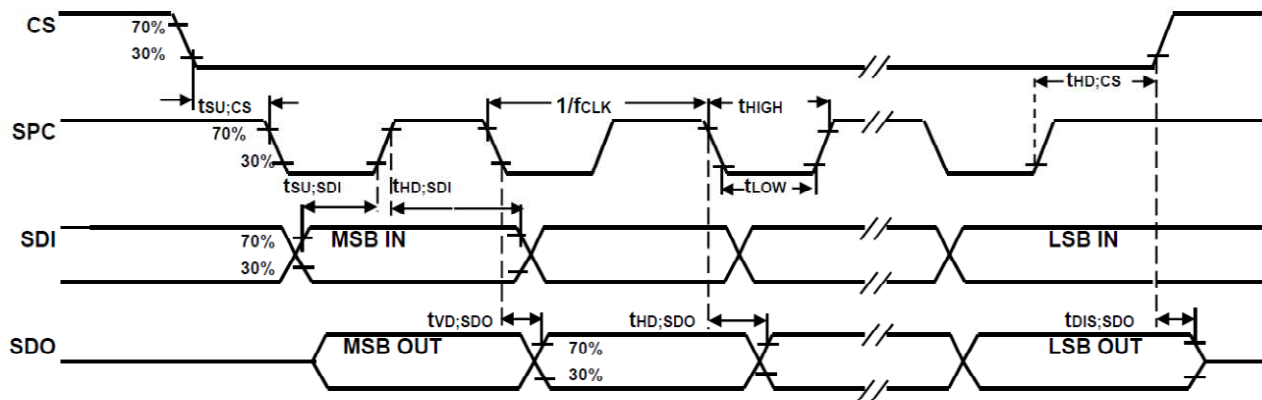
SPI Bus Timing Diagram



6.9 Absolute Maximum Ratings

Stress above those listed as “Absolute Maximum Ratings” may cause permanent damage to the device. These are stress ratings only and functional operation of the device at these conditions is not implied. Exposure to the absolute maximum ratings conditions for extended periods may affect device reliability.

Parameter	Rating
Supply Voltage, VDD	-0.5V to +6V
VLOGIC Input Voltage Level (MPU-6050)	-0.5V to VDD + 0.5V
REGOUT	-0.5V to 2V
Input Voltage Level (CLKIN, AUX_DA, AD0, FSYNC, INT, SCL, SDA)	-0.5V to VDD + 0.5V
CPOUT (2.5V ≤ VDD ≤ 3.6V)	-0.5V to 30V
Acceleration (Any Axis, unpowered)	10,000g for 0.2ms
Operating Temperature Range	-40°C to +105°C
Storage Temperature Range	-40°C to +125°C
Electrostatic Discharge (ESD) Protection	2kV (HBM); 200V (MM)
Latch-up	JEDEC Class II (2), 125°C Level A, ±100mA

7 Applications Information

7.1 Pin Out and Signal Description

Pin Number	MPU-6000	MPU-6050	Pin Name	Pin Description
1	Y	Y	CLKIN	Optional external reference clock input. Connect to GND if unused.
6	Y	Y	AUX_DA	I ² C master serial data, for connecting to external sensors
7	Y	Y	AUX_CL	I ² C Master serial clock, for connecting to external sensors
8	Y		/CS	SPI chip select (0=SPI mode)
8		Y	VLOGIC	Digital I/O supply voltage
9	Y		AD0 / SDO	I ² C Slave Address LSB (AD0); SPI serial data output (SDO)
9		Y	AD0	I ² C Slave Address LSB (AD0)
10	Y	Y	REGOUT	Regulator filter capacitor connection
11	Y	Y	FSYNC	Frame synchronization digital input. Connect to GND if unused.
12	Y	Y	INT	Interrupt digital output (totem pole or open-drain)
13	Y	Y	VDD	Power supply voltage and Digital I/O supply voltage
18	Y	Y	GND	Power supply ground
19, 21	Y	Y	RESV	Reserved. Do not connect.
20	Y	Y	CPOUT	Charge pump capacitor connection
22	Y	Y	CLKOUT	System clock output
23	Y		SCL / SCLK	I ² C serial clock (SCL); SPI serial clock (SCLK)
23		Y	SCL	I ² C serial clock (SCL)
24	Y		SDA / SDI	I ² C serial data (SDA); SPI serial data input (SDI)
24		Y	SDA	I ² C serial data (SDA)
2, 3, 4, 5, 14, 15, 16, 17	Y	Y	NC	Not internally connected. May be used for PCB trace routing.

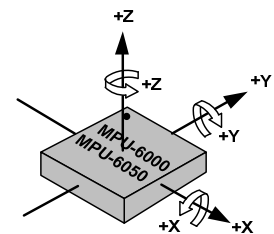
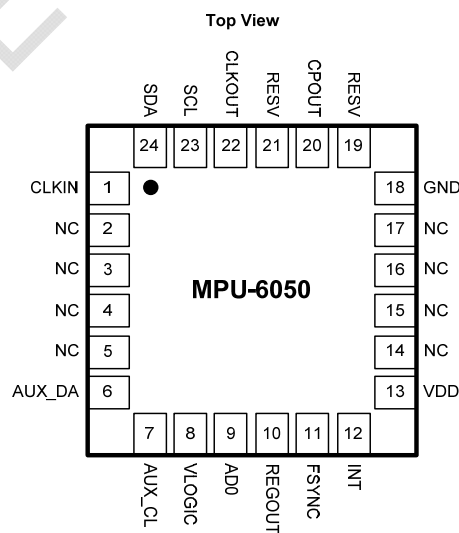
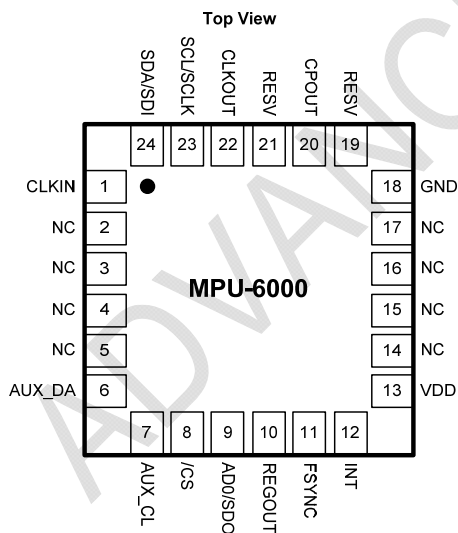

7.2 Typical Operating Circuit

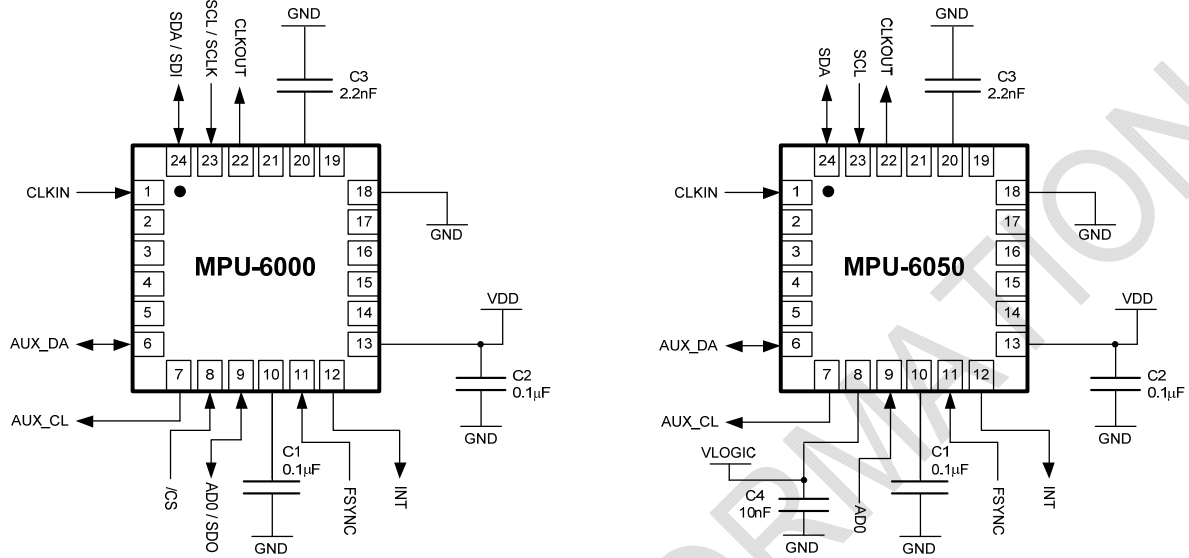

Typical Operating Circuits

7.3 Bill of Materials for External Components

Component	Label	Specification	Quantity
Regulator Filter Capacitor (Pin 10)	C1	Ceramic, X7R, 0.1µF ±10%, 2V	1
VDD Bypass Capacitor (Pin 13)	C2	Ceramic, X7R, 0.1µF ±10%, 4V	1
Charge Pump Capacitor (Pin 20)	C3	Ceramic, X7R, 2.2nF ±10%, 50V	1
VLOGIC Bypass Capacitor (Pin 8)	C4*	Ceramic, X7R, 10nF ±10%, 4V	1

* MPU-6050 Only.

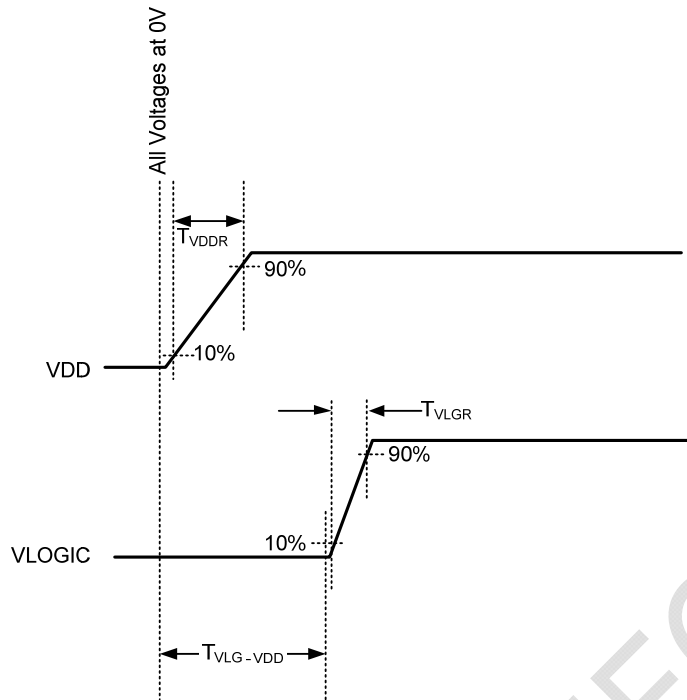
7.4 Recommended Power-on Procedure

Power-Up Sequencing

1. VLOGIC amplitude must always be \leq VDD amplitude
2. T_{VDDR} is VDD rise time: Time for VDD to rise from 10% to 90% of its final value
3. T_{VDDR} is \leq 100ms
4. T_{VLGR} is VLOGIC rise time: Time for VLOGIC to rise from 10% to 90% of its final value
5. T_{VLGR} is \leq 3ms
6. $T_{VLG-VDD}$ is the delay from the start of VDD ramp to the start of VLOGIC rise
7. $T_{VLG-VDD}$ is \geq 0
8. VDD and VLOGIC must be monotonic ramps

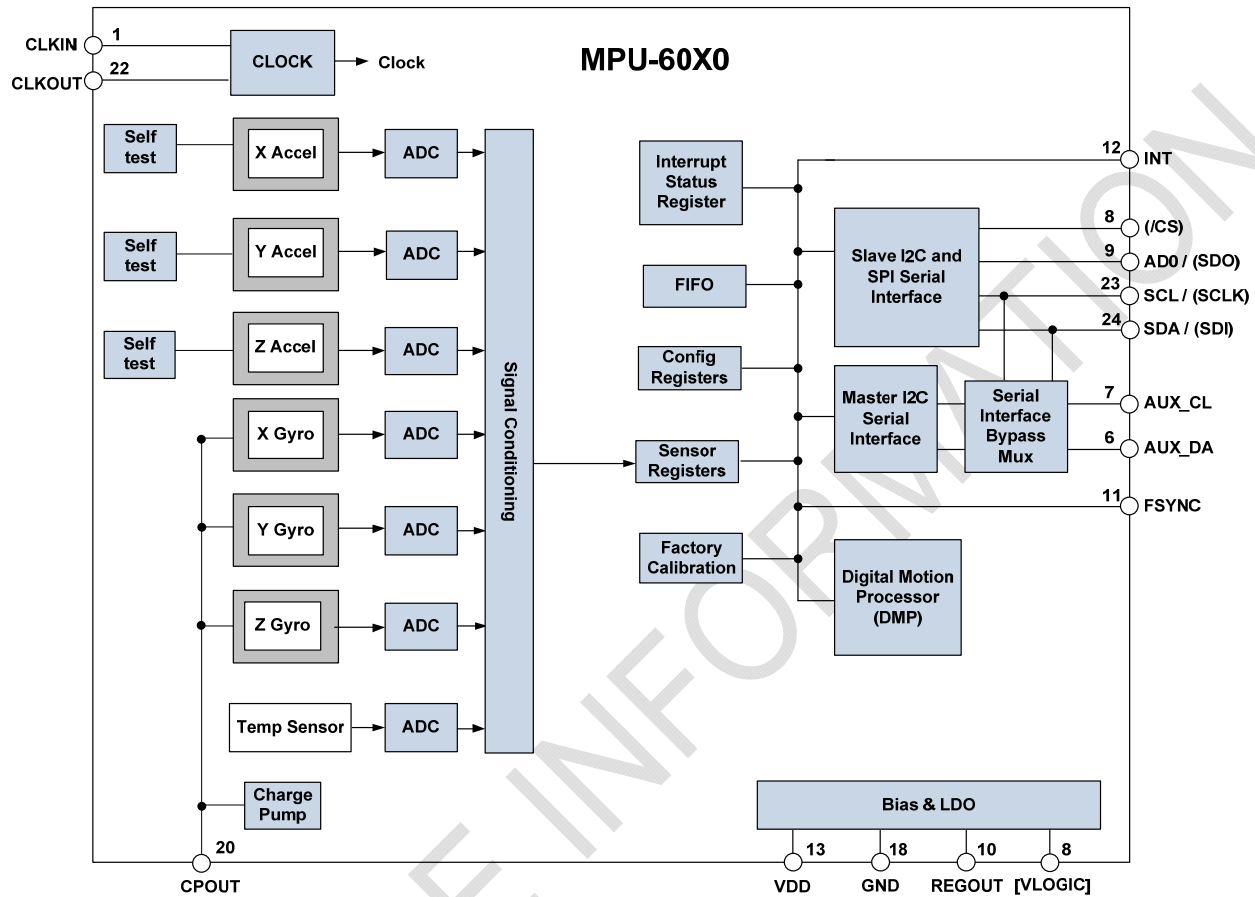
7.5 Block Diagram



Note: Pin names in round brackets () apply only to MPU-6000
 Pin names in square brackets [] apply only to MPU-6050

7.6 Overview

The MPU-60X0 is comprised of the following key blocks and functions:

- Three-axis MEMS rate gyroscope sensor with 16-bit ADCs and signal conditioning
- Three-axis MEMS accelerometer sensor with 16-bit ADCs and signal conditioning
- Digital Motion Processor (DMP) engine
- Primary I²C and SPI (MPU-6000 only) serial communications interfaces
- Auxiliary I²C serial interface for 3rd party magnetometer & other sensors
- Clocking
- Sensor Data Registers
- FIFO
- Interrupts
- Digital-Output Temperature Sensor
- Accelerometer Self-test
- Bias and LDO
- Charge Pump

7.7 Three-Axis MEMS Gyroscope with 16-bit ADCs and Signal Conditioning

The MPU-60X0 consists of three independent vibratory MEMS rate gyroscopes, which detect rotation about the X-, Y-, and Z- Axes. When the gyros are rotated about any of the sense axes, the Coriolis Effect causes a vibration that is detected by a capacitive pickoff. The resulting signal is amplified, demodulated, and filtered to produce a voltage that is proportional to the angular rate. This voltage is digitized using individual on-chip 16-bit Analog-to-Digital Converters (ADCs) to sample each axis. The full-scale range of the gyro sensors may be digitally programmed to ± 250 , ± 500 , ± 1000 , or ± 2000 degrees per second (dps). The ADC sample rate is programmable from 8,000 samples per second, down to 3.9 samples per second, and user-selectable low-pass filters enable a wide range of cut-off frequencies.

7.8 Three-Axis MEMS Accelerometer with 16-bit ADCs and Signal Conditioning

The MPU-60X0's 3-Axis accelerometer uses separate proof masses for each axis. Acceleration along a particular axis induces displacement on the corresponding proof mass, and capacitive sensors detect the displacement differentially. The MPU-60X0's architecture reduces the accelerometers' susceptibility to fabrication variations as well as to thermal drift. When the device is placed on a flat surface, it will measure $0g$ on the X- and Y-axes and $+1g$ on the Z-axis. The accelerometers' scale factor is calibrated at the factory and is nominally independent of supply voltage. Each sensor has a dedicated sigma-delta ADC for providing digital outputs. The full scale range of the digital output can be adjusted to $\pm 2g$, $\pm 4g$, $\pm 8g$, or $\pm 16g$.

7.9 Digital Motion Processor

The embedded Digital Motion Processor (DMP) is located within the MPU-60X0 and offloads computation of motion processing algorithms from the host processor. The DMP acquires data from accelerometers, gyroscopes, and additional 3rd party sensors such as magnetometers, and processes the data. The resulting data can be read from the DMP's registers, or can be buffered in a FIFO. The DMP has access to one of the MPU's external pins, which can be used for generating interrupts.

The purpose of the DMP is to offload both timing requirements and processing power from the host processor. Typically, motion processing algorithms should be run at a high rate, often around 200Hz, in order to provide accurate results with low latency. This is required even if the application updates at a much lower rate; for example, a low power user interface may update as slowly as 5Hz, but the motion processing should still run at 200Hz. The DMP can be used as a tool in order to minimize power, simplify timing, simplify the software architecture, and save valuable MIPS on the host processor for use in the application.

7.10 Primary I²C and SPI Serial Communications Interfaces

The MPU-60X0 communicates to a system processor using either a SPI (MPU-6000 only) or an I²C serial interface. The MPU-60X0 always acts as a slave when communicating to the system processor. The LSB of the of the I²C slave address is set by pin 9 (AD0).

The logic levels for communications between the MPU-60X0 and its master are as follows:

- MPU-6000: The logic level for communications with the master is set by the voltage on VDD
- MPU-6050: The logic level for communications with the master is set by the voltage on VLOGIC

For further information regarding the logic levels of the MPU-6050, please refer to Section 10.