



Chipsmall Limited consists of a professional team with an average of over 10 year of expertise in the distribution of electronic components. Based in Hongkong, we have already established firm and mutual-benefit business relationships with customers from,Europe,America and south Asia,supplying obsolete and hard-to-find components to meet their specific needs.

With the principle of “Quality Parts,Customers Priority,Honest Operation,and Considerate Service”,our business mainly focus on the distribution of electronic components. Line cards we deal with include Microchip,ALPS,ROHM,Xilinx,Pulse,ON,Everlight and Freescale. Main products comprise IC,Modules,Potentiometer,IC Socket,Relay,Connector.Our parts cover such applications as commercial,industrial, and automotives areas.

We are looking forward to setting up business relationship with you and hope to provide you with the best service and solution. Let us make a better world for our industry!



## Contact us

Tel: +86-755-8981 8866 Fax: +86-755-8427 6832

Email & Skype: info@chipsmall.com Web: www.chipsmall.com

Address: A1208, Overseas Decoration Building, #122 Zhenhua RD., Futian, Shenzhen, China



# LIDAR-Lite v2 Overview

## LIDAR-Lite Specifications

General	Technical Specifications
Power	4.75-5.5V DC Nominal, Maximum 6V DC
Weight	PCB 4.5 grams, Module 22 grams with optics and housing
Size	PCB 44.5 X 16.5mm (1.75" by .65")
Housing	20 X 48 X 40mm (.8" X 1.9" X 1.6")
Current Consumption	<2mA @ 1Hz (shutdown between measurements), <100mA (continuous operation)
Max Operating Temp.	70° C
External Trigger	3.3V logic, high-low edge triggered
PWM Range Output	PWM (Pulse Width Modulation) signal proportional to range, 1msec/meter, 10µsec step size
I2C Machine Interface	100Kb – Fixed, 0xC4 slave address. Internal register access & control.
Supported I2C Commands	Single distance measurement, velocity, signal strength
Mode Control	Busy status using I2C, External Trigger input / PWM outputs
Max Range under typical conditions	~40m
Accuracy	+/- 2.5cm, or +/- ~1"
Default Rep Rate	~50 Hz.

## Laser Safety

**CLASS 1 LASER PRODUCT**  
**CLASSIFIED EN/IEC 60825-1 2007**  
Complies with US FDA performance standards for laser products except for deviations pursuant to Laser Notice No. 50, dated June 24, 2007

**PULSEDLIGHT, LLC**  
**LIDAR-Lite Manufacture Date: July 2014**  
PulsedLight, LLC, PO Box 691, Bend, OR 97709  
sensors@pulsedlight3d.com

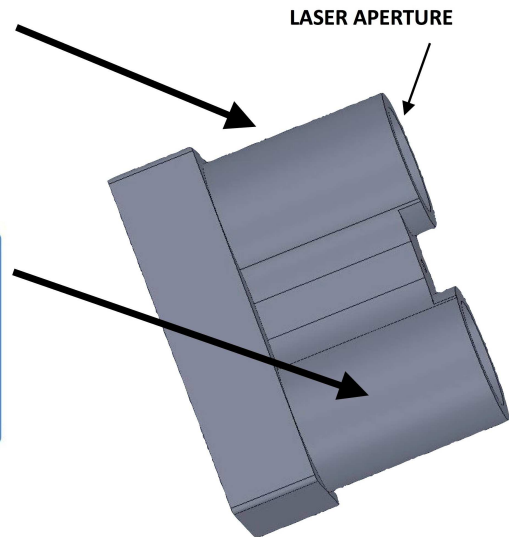

LIDAR-Lite is a laser rangefinder that emits laser radiation. This Laser Product is designated Class 1 during all procedures of operation. This means that the laser is safe to look at with the unaided eye. However, it is very advisable to avoid looking into the beam and power the module off when not in use.

No regular maintenance is required for LIDAR-Lite. In the event that the unit becomes damaged or is inoperable, repair or service of LIDAR-Lite is only to be handled by authorized, factory-trained technicians. No service of LIDAR-Lite by the user is allowed. Attempting to repair or service the unit on your own can result in direct exposure to laser radiation and the risk of permanent eye damage. For repair or service please contact PulsedLight directly for a return authorization.

No user should modify LIDAR-Lite or operate it without its housing or optics. The operation of LIDAR-Lite without a housing and optics or modification of the housing or optics that exposes the laser source may result in direct exposure to laser radiation and the risk of permanent eye damage. Removal or modification of the diffuser in front of the laser optic may result in the risk of permanent eye damage.

Caution – Use of controls or adjustments or performance of procedures other than those specified herein may result in hazardous radiation exposure. PulsedLight is not responsible for injuries caused through the improper use or operation of this product.

# Class 1 Laser Product

This Laser Product is designated Class 1 during all procedures of operation.

<b>Parameters</b>	<b>Laser Value</b>
Wavelength	905nm (nominal)
Total Laser Power - Peak	1.3Watts
Mode of operation	Pulsed (max pulse train 256 pulses)
Pulse Width	0.5 $\mu$ Sec (50% duty Cycle)
Pulse Repetition Frequency	10-20KHz nominal
Energy per Pulse	<280nJ
Beam Diameter at laser aperture	12mm x 2mm
Divergence	4mRadian x 2mRadian (Approx)

## LIDAR-Lite Signal & Power Interface Definitions

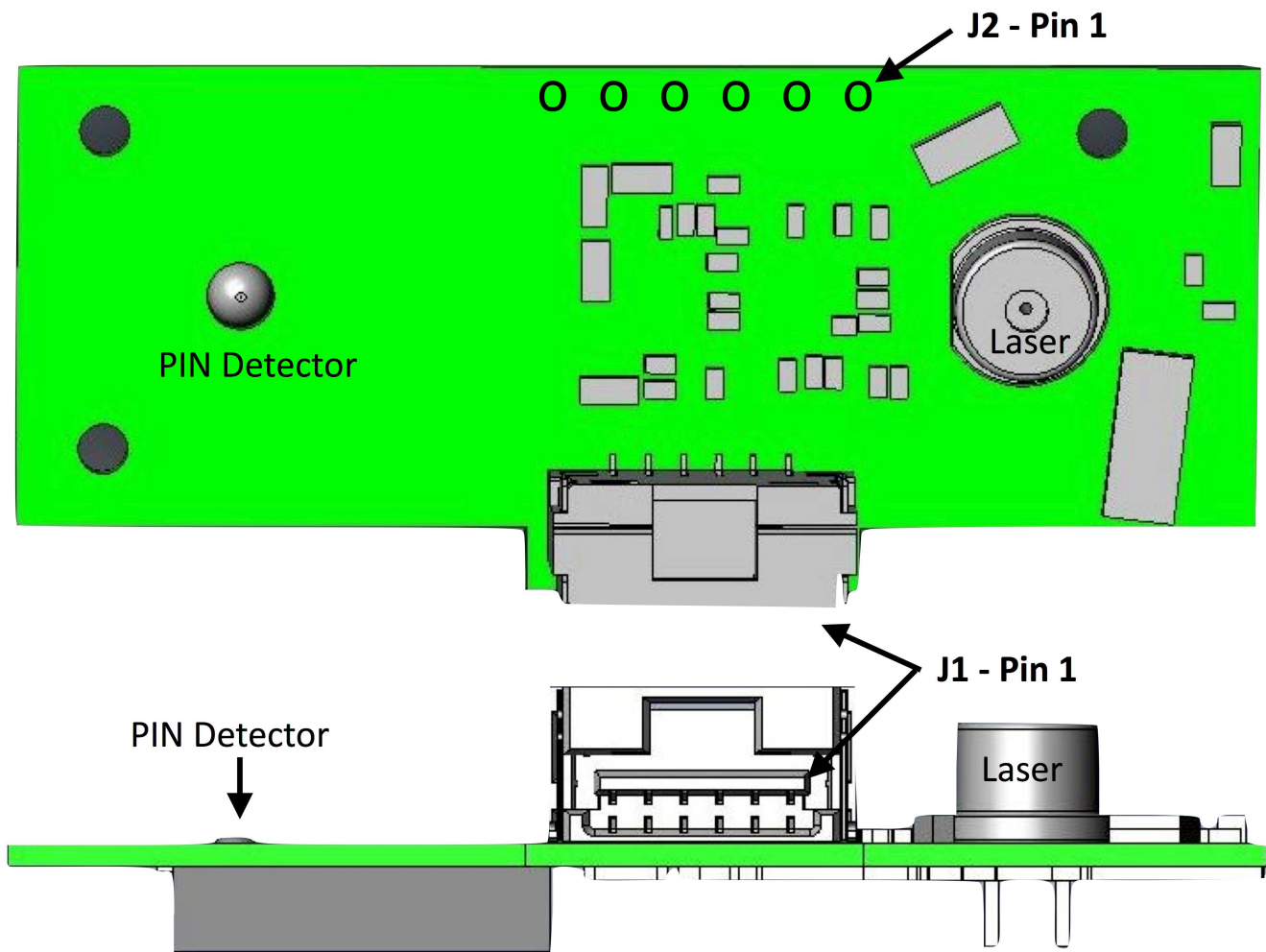

# J1 - Primary interface

**Board Connector:** Molex part #5023860670 (DigiKey Part #: WM3917CT-ND)

**Mating Connector:** Molex # 5023800600 PLUG HSG 6POS (DigiKey Part #: WM2271-ND)

Pin	Description
PIN1	POWER_IN - 4.75-5.5V DC Nominal, Maximum 6V DC. Peak current draw from this input (which occurs during acquisition period) is typically < 100 mA over a duration from 4 to 20ms depending on received signal strength. Unless you use power management, the unit will draw 80 mA between acquisition times.
PIN2	POWER_EN - Active high, enables operation of the 3.3V micro-controller regulator. Low puts board to sleep, draws <40 $\mu$ A. (Internal 100K pull-up)
PIN3	Mode Select - Provides trigger (high-low edge) PWM out (high)
PIN4	I2C Clock (SCL)

PIN5	I2C Data (SDA)
PIN6	Signal/power ground.

## J2 - Secondary signal/power - .1" spacing Molex style through hole (Factory Option Only)

Pin	Description
PIN1	Laser Bypass 5-20V max (nominally connected to pin 2 through inductor L8 - removed for external power)
PIN2	POWER_IN - 4.75-5.5V DC Nominal, Maximum 6V DC
PIN3	POWER_EN - Active high
PIN4	External reference clock input (Factory Option - Consult Factory)
PIN5	Signal/power ground.
PIN6	Detector bias - up to 25V external bias for PIN, external bias input 200V for APD (consult factory)

# Module Mechanical Drawings & Dimensions

[Download Housing and Cover in PNG, STL, STEP and SLDPRT formats on GitHub](#)

PulsedLight, Inc. - LIDAR-Lite Housing

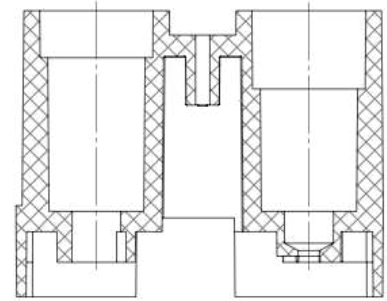
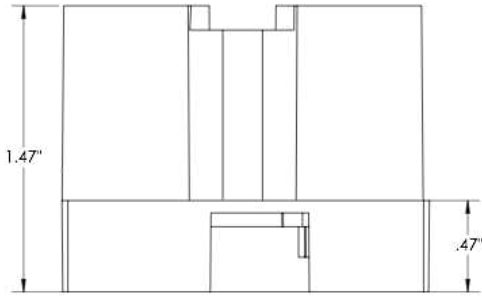
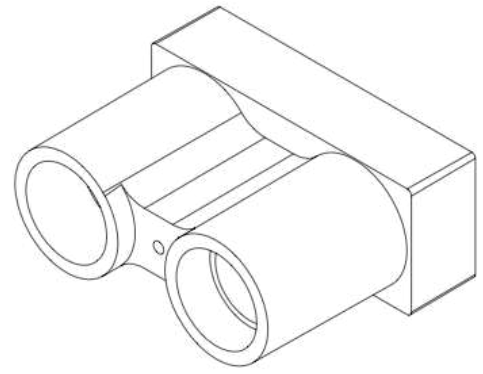
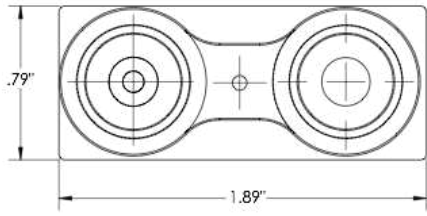

SECTION A-A

PulsedLight Inc. - LIDAR-Lite Housing Cover

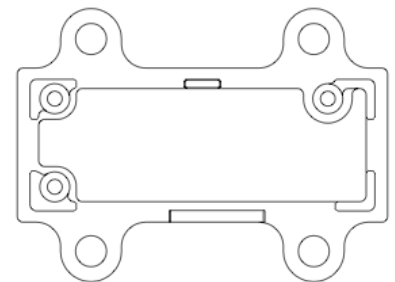
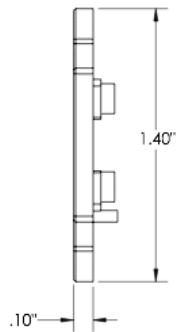
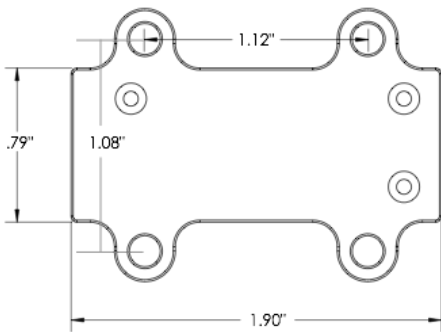
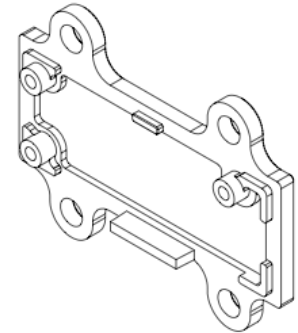
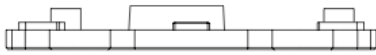

Notes: - The hole diameters at their smallest are 0.15" or 0.385 cm with a little rounding erring small

# PCB Dimensions

Backside viewed through board

