



Chipsmall Limited consists of a professional team with an average of over 10 year of expertise in the distribution of electronic components. Based in Hongkong, we have already established firm and mutual-benefit business relationships with customers from,Europe,America and south Asia,supplying obsolete and hard-to-find components to meet their specific needs.

With the principle of “Quality Parts,Customers Priority,Honest Operation,and Considerate Service”,our business mainly focus on the distribution of electronic components. Line cards we deal with include Microchip,ALPS,ROHM,Xilinx,Pulse,ON,Everlight and Freescale. Main products comprise IC,Modules,Potentiometer,IC Socket,Relay,Connector.Our parts cover such applications as commercial,industrial, and automotives areas.

We are looking forward to setting up business relationship with you and hope to provide you with the best service and solution. Let us make a better world for our industry!



## Contact us

Tel: +86-755-8981 8866 Fax: +86-755-8427 6832

Email & Skype: info@chipsmall.com Web: www.chipsmall.com

Address: A1208, Overseas Decoration Building, #122 Zhenhua RD., Futian, Shenzhen, China





# Lidar Lite v3 Operation Manual and Technical Specifications

## Laser Safety

### ⚠ WARNING

This device requires no regular maintenance. In the event that the device becomes damaged or is inoperable, repair or service must be handled by authorized, factory-trained technicians only. Attempting to repair or service the unit on your own can result in direct exposure to laser radiation and the risk of permanent eye damage. For repair or service, contact your dealer or Garmin® for more information. This device should not be modified or operated without its housing or optics. Operating this device without a housing and optics, or operating this device with modified housing or optics that expose the laser source, may result in direct exposure to laser radiation and the risk of permanent eye damage. Removal or modification of the diffuser in front of the laser optic may result in the risk of permanent eye damage.

Use of controls or adjustments or performance of procedures other than those specified in this documentation may result in hazardous radiation exposure. Garmin is not responsible for injuries caused through the improper use or operation of this product.

### ⚠ CAUTION

This device emits laser radiation. This Laser Product is designated Class 1 during all procedures of operation. This designation means that the laser is safe to look at with the unaided eye, however it is advisable to avoid looking into the beam when operating the device and to turn off the module when not in use.

## Documentation Revision Information

Rev	Date	Changes
0A	09/2016	Initial release

## Table of Contents

- Lidar Lite v3 Operation Manual and Technical Specifications ..... 1**
- Laser Safety ..... 1
- Documentation Revision Information..... 1
- Specifications ..... 2**
- Physical ..... 2
- Electrical ..... 2
- Performance ..... 2
- Interface..... 2
- Laser..... 2
- Connections ..... 2**
- Wiring Harness ..... 2
- Connector ..... 2
  - Connector Port Identification ..... 2
- I2C Connection Diagrams ..... 3
  - Standard I2C Wiring ..... 3
  - Standard Arduino I2C Wiring ..... 3
  - PWM Wiring..... 3
  - PWM Arduino Wiring..... 3
- Operational Information ..... 4**
- Technology ..... 4
- Theory of Operation..... 4
- Interface..... 4
  - Initialization ..... 4
  - Power Enable Pin ..... 4
  - I2C Interface ..... 4
  - Mode Control Pin..... 4
  - Settings..... 4
- I2C Protocol Information..... 6**
- I2C Protocol Operation ..... 7
- Register Definitions ..... 7
  - Control Register List ..... 7
  - Detailed Control Register Definitions..... 8
- Frequently Asked Questions ..... 12**
- Must the device run on 5 Vdc? Can it run on 3.3 Vdc instead?..... 12
- What is the spread of the laser beam?..... 12
- How do distance, target size, aspect, and reflectivity effect returned signal strength?..... 12
- How does the device work with reflective surfaces? ..... 12
  - Diffuse Reflective Surfaces..... 12
  - Specular Surfaces ..... 12
- How does liquid affect the signal? ..... 13

# Specifications

## Physical

Specification	Measurement
Size (LxWxH)	20 × 48 × 40 mm (0.8 × 1.9 × 1.6 in.)
Weight	22 g (0.78 oz.)
Operating temperature	-20 to 60°C (-4 to 140°F)

## Electrical

Specification	Measurement
Power	5 Vdc nominal 4.5 Vdc min., 5.5 Vdc max.
Current consumption	105 mA idle 135 mA continuous operation

## Performance

Specification	Measurement
Range (70% reflective target)	40 m (131 ft)
Resolution	+/- 1 cm (0.4 in.)
Accuracy < 5 m	±2.5 cm (1 in.) typical*
Accuracy ≥ 5 m	±10 cm (3.9 in.) typical Mean ±1% of distance maximum Ripple ±1% of distance maximum
Update rate (70% Reflective Target)	270 Hz typical 650 Hz fast mode** >1000 Hz short range only
Repetition rate	~50 Hz default 500 Hz max

\*Nonlinearity present below 1 m (39.4 in.)

\*\*Reduced sensitivity

## Interface

Specification	Measurement
User interface	I2C PWM External trigger
I2C interface	Fast-mode (400 kbit/s) Default 7-bit address 0x62 Internal register access & control
PWM interface	External trigger input PWM output proportional to distance at 10 µs/cm

## Laser

Specification	Measurement
Wavelength	905 nm (nominal)
Total laser power (peak)	1.3 W
Mode of operation	Pulsed (256 pulse max. pulse train)
Pulse width	0.5 µs (50% duty Cycle)
Pulse train repetition frequency	10-20 KHz nominal
Energy per pulse	<280 nJ
Beam diameter at laser aperture	12 × 2 mm (0.47 × 0.08 in.)
Divergence	8 mRadian

# Connections

## Wiring Harness

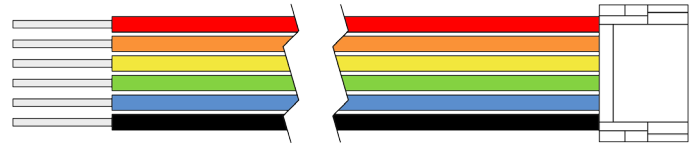

Wire Color	Function
Red	5 Vdc (+)
Orange	Power enable (internal pull-up)
Yellow	Mode control
Green	I2C SCL
Blue	I2C SDA
Black	Ground (-)

There are two basic configurations for this device:

- **I2C (Inter-Integrated Circuit)**—a serial computer bus used to communicate between this device and a microcontroller, such as an Arduino board (“I2C Interface”, page 4).
- **PWM (Pulse Width Modulation)**—a bi-directional signal transfer method that triggers acquisitions and returns distance measurements using the mode-control pin (“Mode Control Pin”, page 4).

## Connector

You can create your own wiring harness if needed for your project or application. The needed components are readily available from many suppliers.

Part	Description	Manufacturer	Part Number
Connector housing	6-position, rectangular housing, latch-lock connector receptacle with a 1.25 mm (0.049 in.) pitch.	JST	GHR-06V-S
Connector terminal	26-30 AWG crimp socket connector terminal (up to 6)	JST	SSHL-002T-P0.2
Wire	UL 1061 26 AWG stranded copper	N/A	N/A

## Connector Port Identification

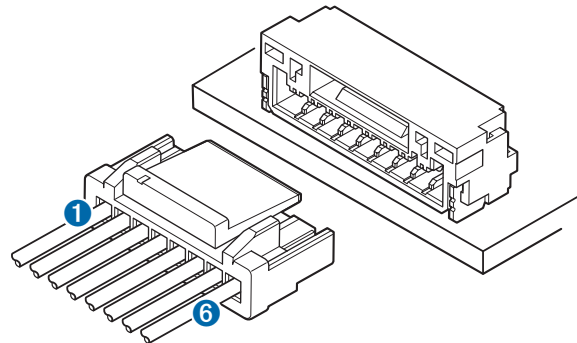

Item	Pin	Function
1	1	5 Vdc (+)
	2	Power enable (internal pull-up)
	3	Mode control
	4	I2C SCL
	5	I2C SDA
6	6	Ground (-)



## I2C Connection Diagrams

### Standard I2C Wiring

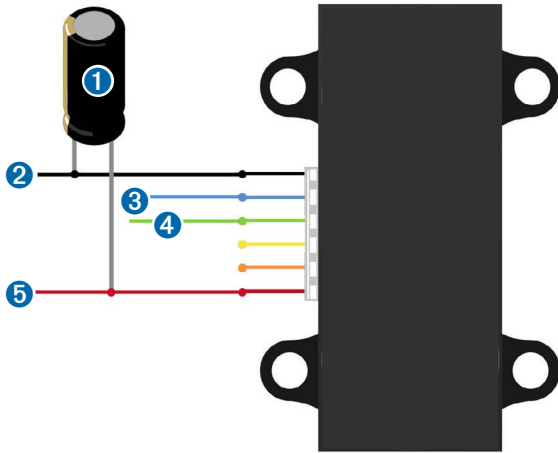

Item	Description	Notes
1	680µF electrolytic capacitor	You must observe the correct polarity when installing the capacitor.
2	Power ground (-) connection	Black wire
3	I2C SDA connection	Blue wire
4	I2C SCA connection	Green wire
5	5 Vdc power (+) connection	Red wire The sensor operates at 4.75 through 5.5 Vdc, with a max. of 6 Vdc.

### Standard Arduino I2C Wiring

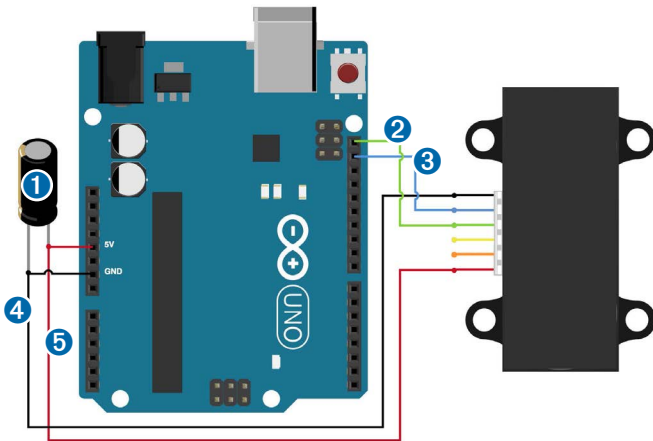

Item	Description	Notes
1	680µF electrolytic capacitor	You must observe the correct polarity when installing the capacitor.
2	I2C SCA connection	Green wire
3	I2C SDA connection	Blue wire
4	Power ground (-) connection	Black wire
5	5 Vdc power (+) connection	Red wire The sensor operates at 4.75 through 5.5 Vdc, with a max. of 6 Vdc.

### PWM Wiring

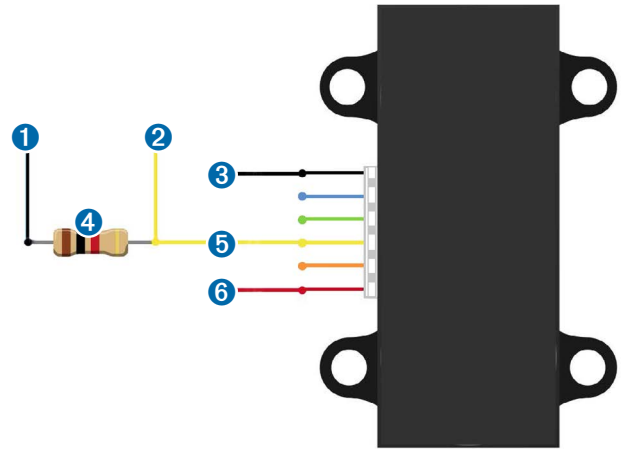

Item	Description	Notes
1	Trigger pin on microcontroller	Connect the other side of the resistor to the trigger pin on your microcontroller.
2	Monitor pin on microcontroller	Connect one side of the resistor to the mode-control connection on the device, and to a monitoring pin on your microcontroller.
3	Power ground (-) connection	Black Wire
4	1kΩ resistor	
5	Mode-control connection	Yellow wire
6	5 Vdc power (+) connection	Red wire The sensor operates at 4.75 through 5.5 Vdc, with a max. of 6 Vdc.

### PWM Arduino Wiring

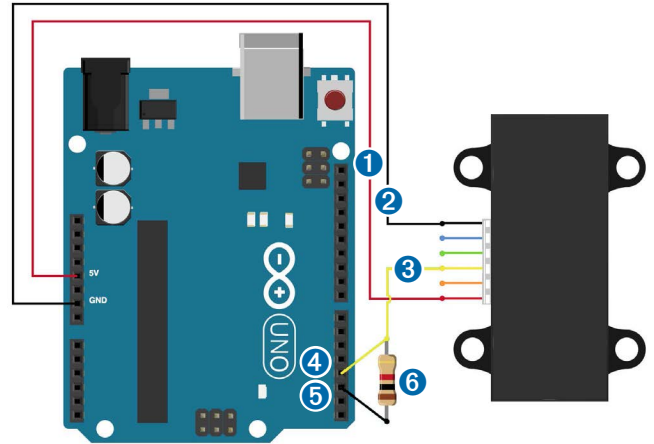

Item	Description	Notes
1	5 Vdc power (+) connection	Red wire The sensor operates at 4.75 through 5.5 Vdc, with a max. of 6 Vdc.
2	Power ground (-) connection	Black Wire
3	Mode-control connection	Yellow wire
4	Monitor pin on microcontroller	Connect one side of the resistor to the mode-control connection on the device, and to a monitoring pin on your microcontroller.
5	Trigger pin on microcontroller	Connect the other side of the resistor to the trigger pin on your microcontroller.
6	1kΩ resistor	

# Operational Information

## Technology

This device measures distance by calculating the time delay between the transmission of a Near-Infrared laser signal and its reception after reflecting off of a target. This translates into distance using the known speed of light. Our unique signal processing approach transmits a coded signature and looks for that signature in the return, which allows for highly effective detection with eye-safe laser power levels. Proprietary signal processing techniques are used to achieve high sensitivity, speed, and accuracy in a small, low-power, and low-cost system

## Theory of Operation

To take a measurement, this device first performs a receiver bias correction routine, correcting for changing ambient light levels and allowing maximum sensitivity.

Then the device sends a reference signal directly from the transmitter to the receiver. It stores the transmit signature, sets the time delay for “zero” distance, and recalculates this delay periodically after several measurements.

Next, the device initiates a measurement by performing a series of acquisitions. Each acquisition is a transmission of the main laser signal while recording the return signal at the receiver. If there is a signal match, the result is stored in memory as a correlation record. The next acquisition is summed with the previous result. When an object at a certain distance reflects the laser signal back to the device, these repeated acquisitions cause a peak to emerge, out of the noise, at the corresponding distance location in the correlation record.

The device integrates acquisitions until the signal peak in the correlation record reaches a maximum value. If the returned signal is not strong enough for this to occur, the device stops at a predetermined maximum acquisition count.

Signal strength is calculated from the magnitude of the signal record peak and a valid signal threshold is calculated from the noise floor. If the peak is above this threshold the measurement is considered valid and the device will calculate the distance, otherwise it will report 1 cm. When beginning the next measurement, the device clears the signal record and starts the sequence again.

## Interface

### Initialization

On power-up or reset, the device performs a self-test sequence and initializes all registers with default values. After roughly 22 ms distance measurements can be taken with the I2C interface or the Mode Control Pin.

### Power Enable Pin

The enable pin uses an internal pullup resistor, and can be driven low to shut off power to the device.

### I2C Interface

This device has a 2-wire, I2C-compatible serial interface (refer to I2C-Bus Specification, Version 2.1, January 2000, available from Philips Semiconductor). It can be connected to an I2C bus as a slave device, under the control of an I2C master device. It supports 400 kHz Fast Mode data transfer.

The I2C bus operates internally at 3.3 Vdc. An internal level shifter allows the bus to run at a maximum of 5 Vdc. Internal 3k ohm pullup resistors ensure this functionality and allow for a simple connection to the I2C host.

The device has a 7-bit slave address with a default value of 0x62. The effective 8-bit I2C address is 0xC4 write and 0xC5 read. The device will not respond to a general call. Support is not provided for 10-bit addressing.

Setting the most significant bit of the I2C address byte to one triggers automatic incrementing of the register address with successive reads or writes within an I2C block transfer. This is commonly used to read the two bytes of a 16-bit value within one transfer and is used in the following example.

The simplest method of obtaining measurement results from the I2C interface is as follows:

- 1 Write 0x04 to register 0x00.
- 2 Read register 0x01. Repeat until bit 0 (LSB) goes low.
- 3 Read two bytes from 0x8f (High byte 0x0f then low byte 0x10) to obtain the 16-bit measured distance in centimeters.

A list of all available control registers is available on [page 7](#).

For more information about the I2C protocol, see [I2C Protocol Operation \(page 7\)](#).

### Mode Control Pin

The mode control pin provides a means to trigger acquisitions and return the measured distance via Pulse Width Modulation (PWM) without having to use the I2C interface.

The idle state of the mode control pin is high impedance (High-Z). Pulling the mode control pin low will trigger a single measurement, and the device will respond by driving the line high with a pulse width proportional to the measured distance at 10  $\mu$ s/cm. A 1k ohm termination resistance is required to prevent bus contention.

The device drives the mode control pin high at 3.3 Vdc. Diode isolation allows the pin to tolerate a maximum of 5 Vdc.

As shown in the diagram [PWM Arduino Wiring \(page 3\)](#), a simple triggering method uses a 1k ohm resistor in series with a host output pin to pull the mode control pin low to initiate a measurement, and a host input pin connected directly to monitor the low-to-high output pulse width.

If the mode control pin is held low, the acquisition process will repeat indefinitely, producing a variable frequency output proportional to distance.

The mode control pin behavior can be modified with the ACQ\_CONFIG\_REG (0x04) I2C register as detailed in [0x04 \(page 8\)](#).

### Settings

The device can be configured with alternate parameters for the distance measurement algorithm. This can be used to customize performance by enabling configurations that allow choosing between speed, range and sensitivity. Other useful features are also detailed in this section. See the full register map ([Control Register List \(page 7\)](#)) for additional settings not mentioned here.

### Receiver Bias Correction

Address	Name	Description	Initial Value
0x00	ACQ_COMMAND	Device command	--

- Write 0x00: Reset device, all registers return to default values
- Write 0x03: Take distance measurement without receiver bias correction
- Write 0x04: Take distance measurement with receiver bias correction

Faster distance measurements can be performed by omitting the receiver bias correction routine. Measurement accuracy and sensitivity are adversely affected if conditions change (e.g. target distance, device temperature, and optical noise). To achieve good performance at high measurement rates receiver bias correction must be performed periodically. The recommended method is to do so at the beginning of every 100 sequential measurement commands.

### Maximum Acquisition Count

Address	Name	Description	Initial Value
0x02	SIG_COUNT_VAL	Maximum acquisition count	0x80

The maximum acquisition count limits the number of times the device will integrate acquisitions to find a correlation record peak (from a returned signal), which occurs at long range or with low target reflectivity. This controls the minimum measurement rate and maximum range. The unit-less relationship is roughly as follows: rate = 1/n and range = n^(1/4), where n is the number of acquisitions.

### Measurement Quick Termination Detection

Address	Name	Description	Initial Value
0x04	ACQ_CONFIG_REG	Acquisition mode control	0x08

You can enable quick-termination detection by clearing bit 3 in this register. The device will terminate a distance measurement early if it anticipates that the signal peak in the correlation record will reach maximum value. This allows for faster and slightly less accurate operation at strong signal strengths without sacrificing long range performance.

### Detection Sensitivity

Address	Name	Description	Initial Value
0x1c	THRESHOLD_BYPASS	Peak detection threshold bypass	0x00

The default valid measurement detection algorithm is based on the peak value, signal strength, and noise in the correlation record. This can be overridden to become a simple threshold criterion by setting a non-zero value. Recommended non-default values are 0x20 for higher sensitivity with more frequent erroneous measurements, and 0x60 for reduced sensitivity and fewer erroneous measurements.

### Burst Measurements and Free Running Mode

Address	Name	Description	Initial Value
0x04	ACQ_CONFIG_REG	Acquisition mode control	0x08
0x11	OUTER_LOOP_COUNT	Burst measurement count control	0x00
0x45	MEASURE_DELAY	Delay between automatic measurements	0x14

The device can be configured to take multiple measurements for each measurement command or repeat indefinitely for free running mode.

OUTER\_LOOP\_COUNT (0x11) controls the number of times the device will retrigger itself. Values 0x00 or 0x01 result in the default one measurement per command. Values 0x02 to 0xfe directly set the repetition count. Value 0xff will enable free running mode after the host device sends an initial measurement command.

The default delay between automatic measurements corresponds to a 10 Hz repetition rate. Set bit 5 in ACQ\_CONFIG\_REG (0x04) to use the delay value in MEASURE\_DELAY (0x45) instead. A delay value of 0x14 roughly corresponds to 100Hz.

The delay is timed from the completion of each measurement. The means that measurement duration, which varies with returned signal strength, will affect the repetition rate. At low repetition rates (high delay) this effect is small, but for lower delay values it is recommended to limit the maximum acquisition count if consistent frequency is desired.

### Velocity

Address	Name	Description	Initial Value
0x09	VELOCITY	Velocity measurement output	--

The velocity measurement is the difference between the current measurement and the previous one, resulting in a signed (2's complement) 8-bit number in cm. Positive velocity is away from the device. This can be combined with free running mode for a constant measurement frequency. The default free running frequency of 10 Hz therefore results in a velocity measurement in .1 m/s.

### Configurable I2C Address

Address	Name	Description	Initial Value
0x16	UNIT_ID_HIGH	Serial number high byte	Unique
0x17	UNIT_ID_LOW	Serial number low byte	Unique
0x18	I2C_ID_HIGH	Write serial number high byte for I2C address unlock	--
0x19	I2C_ID_LOW	Write serial number low byte for I2C address unlock	--
0x1a	I2C_SEC_ADDR	Write new I2C address after unlock	--
0x1e	I2C_CONFIG	Default address response control	0x00

The I2C address can be changed from its default value. Available addresses are 7-bit values with a '0' in the least significant bit (even hexadecimal numbers).

To change the I2C address, the unique serial number of the unit must be read then written back to the device before setting the new address. The process is as follows:

- 1 Read the two byte serial number from 0x96 (High byte 0x16 and low byte 0x17).
- 2 Write the serial number high byte to 0x18.
- 3 Write the serial number low byte to 0x19.
- 4 Write the desired new I2C address to 0x1a.
- 5 Write 0x08 to 0x1e to disable the default address.

This can be used to run multiple devices on a single bus, by enabling one, changing its address, then enabling the next device and repeating the process.

The I2C address will be restored to default after a power cycle.

### Power Control

Address	Name	Description	Initial Value
0x65	POWER_CONTROL	Power state control	0x80

**NOTE:** The most effective way to control power usage is to utilize the enable pin to deactivate the device when not in use.

Another option is to set bit 0 in this register which disables the receiver circuit, saving roughly 40mA. After being re-enabled, the receiver circuit stabilizes by the time a measurement can be performed. Setting bit 2 puts the device in sleep mode until the next I2C transaction, saving 20mA. **Since the wake-up time is only around 2 m/s shorter than the full power-on time, and both will reset all registers, it is recommended to use the enable pin instead.**

## I2C Protocol Information

This device has a 2-wire, I2C-compatible serial interface (refer to I2C-Bus Specification, Version 2.1, January 2000, available from Philips Semiconductor). It can be connected to an I2C bus as a slave device, under the control of an I2C master device. It supports standard 400 kHz data transfer mode. Support is not provided for 10-bit addressing.

The Sensor module has a 7-bit slave address with a default value of 0x62 in hexadecimal notation. The effective 8 bit I2C address is: 0xC4 write, 0xC5 read. The device will not presently respond to a general call.

### Write

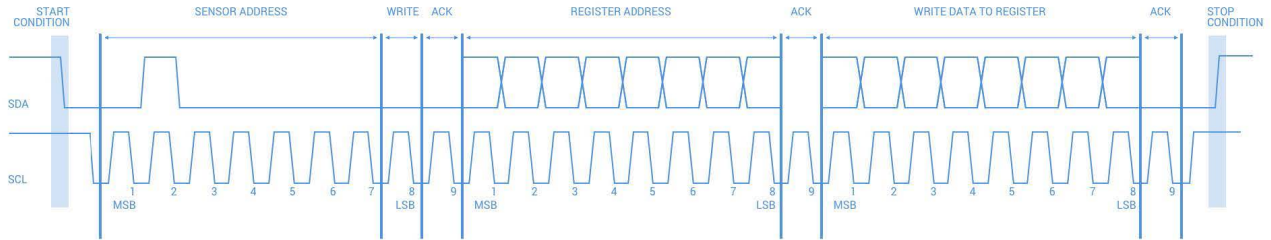

### Read

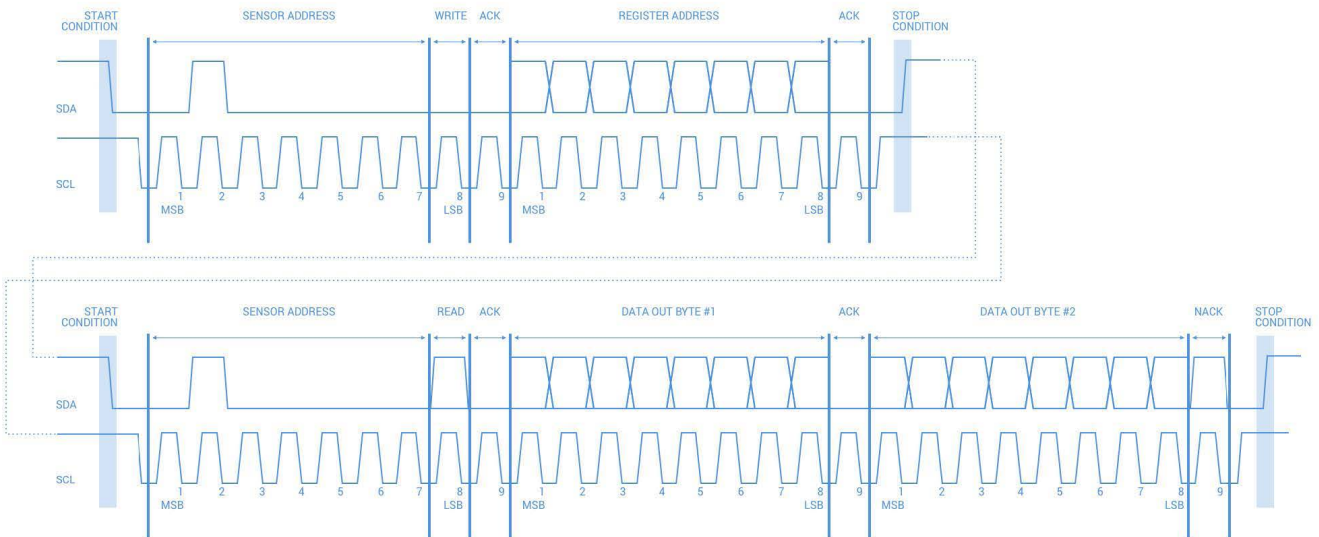

#### Notes:

- This device does not work with repeated START conditions. It must first receive a STOP condition before a new START condition.
- The ACK and NACK items are responses from the master device to the slave device.
- The last NACK in the read is technically optional, but the formal I2C protocol states that the master shall not acknowledge the last byte.

## I2C Protocol Operation

The I2C serial bus protocol operates as follows:

- 1 The master initiates data transfer by establishing a start condition, which is when a high-to-low transition on the SDA line occurs while SCL is high. The following byte is the address byte, which consists of the 7-bit slave address followed by a read/write bit with a zero state indicating a write request. A write operation is used as the initial stage of both read and write transfers. If the slave address corresponds to the module's address the unit responds by pulling SDA low during the ninth clock pulse (this is termed the acknowledge bit). At this stage, all other devices on the bus remain idle while the selected device waits for data to be written to or read from its shift register.
- 2 Data is transmitted over the serial bus in sequences of nine clock pulses (eight data bits followed by an acknowledge bit). The transitions on the SDA line must occur during the low period of SCL and remain stable during the high period of SCL.
- 3 An 8 bit data byte following the address loads the I2C control register with the address of the first control register to be read along with flags indicating if auto increment of the addressed control register is desired with successive reads or writes; and if access to the internal micro or external correlation processor register space is requested. Bit locations 5:0 contain the control register address while bit 7 enables the automatic incrementing of control register with successive data blocks. Bit position 6 selects correlation memory external to the microcontroller if set. (Presently an advanced feature)
- 4 If a read operation is requested, a stop bit is issued by the master at the completion of the first data frame followed by the initiation of a new start condition, slave address with the read bit set (one state). The new address byte is followed by the reading of one or more data bytes succession. After the slave has acknowledged receipt of a valid address, data read operations proceed by the master releasing the I2C data line SDA with continuing clocking of SCL. At the completion of the receipt of a data byte, the master must strobe the acknowledge bit before continuing the read cycle.
- 5 For a write operation to proceed, Step 3 is followed by one or more 8 bit data blocks with acknowledges provided by the slave at the completion of each successful transfer. At the completion of the transfer cycle a stop condition is issued by the master terminating operation.

## Register Definitions

### Control Register List

Address	R/W	Name	Description	Initial Value	Details
0x00	W	ACQ_COMMAND	Device command	--	<a href="#">page 8</a>
0x01	R	STATUS	System status	--	<a href="#">page 8</a>
0x02	R/W	SIG_COUNT_VAL	Maximum acquisition count	0x80	<a href="#">page 8</a>
0x04	R/W	ACQ_CONFIG_REG	Acquisition mode control	0x08	<a href="#">page 8</a>
0x09	R	VELOCITY	Velocity measurement output	--	<a href="#">page 8</a>
0x0c	R	PEAK_CORR	Peak value in correlation record	--	<a href="#">page 8</a>
0x0d	R	NOISE_PEAK	Correlation record noise floor	--	<a href="#">page 8</a>
0x0e	R	SIGNAL_STRENGTH	Received signal strength	--	<a href="#">page 9</a>
0x0f	R	FULL_DELAY_HIGH	Distance measurement high byte	--	<a href="#">page 9</a>
0x10	R	FULL_DELAY_LOW	Distance measurement low byte	--	<a href="#">page 9</a>
0x11	R/W	OUTER_LOOP_COUNT	Burst measurement count control	0x01	<a href="#">page 9</a>
0x12	R/W	REF_COUNT_VAL	Reference acquisition count	0x05	<a href="#">page 9</a>
0x14	R	LAST_DELAY_HIGH	Previous distance measurement high byte	--	<a href="#">page 9</a>
0x15	R	LAST_DELAY_LOW	Previous distance measurement low byte	--	<a href="#">page 9</a>
0x16	R	UNIT_ID_HIGH	Serial number high byte	Unique	<a href="#">page 9</a>
0x17	R	UNIT_ID_LOW	Serial number low byte	Unique	<a href="#">page 9</a>
0x18	W	I2C_ID_HIGH	Write serial number high byte for I2C address unlock	--	<a href="#">page 9</a>
0x19	W	I2C_ID_LOW	Write serial number low byte for I2C address unlock	--	<a href="#">page 9</a>
0x1a	R/W	I2C_SEC_ADDR	Write new I2C address after unlock	--	<a href="#">page 9</a>
0x1c	R/W	THRESHOLD_BYPASS	Peak detection threshold bypass	0x00	<a href="#">page 9</a>
0x1e	R/W	I2C_CONFIG	Default address response control	0x00	<a href="#">page 9</a>
0x40	R/W	COMMAND	State command	--	<a href="#">page 10</a>
0x45	R/W	MEASURE_DELAY	Delay between automatic measurements	0x14	<a href="#">page 10</a>
0x4c	R	PEAK_BCK	Second largest peak value in correlation record	--	<a href="#">page 10</a>
0x52	R	CORR_DATA	Correlation record data low byte	--	<a href="#">page 10</a>
0x53	R	CORR_DATA_SIGN	Correlation record data high byte	--	<a href="#">page 10</a>
0x5d	R/W	ACQ_SETTINGS	Correlation record memory bank select	--	<a href="#">page 10</a>
0x65	R/W	POWER_CONTROL	Power state control	0x80	<a href="#">page 10</a>



## Detailed Control Register Definitions

**NOTE:** Unless otherwise noted, all registers contain one byte and are read and write.

### 0x00

R/W	Name	Description	Initial Value
W	ACQ_COMMAND	Device command	--

Bit	Function
7:0	Write 0x00: Reset FPGA, all registers return to default values Write 0x03: Take distance measurement without receiver bias correction Write 0x04: Take distance measurement with receiver bias correction

### 0x01

R/W	Name	Description	Initial Value
R	STATUS	System status	--

Bit	Function
6	Process Error Flag 0: No error detected 1: System error detected during measurement
5	Health Flag 0: Error detected 1: Reference and receiver bias are operational
4	Secondary Return Flag 0: No secondary return detected 1: Secondary return detected in correlation record
3	Invalid Signal Flag 0: Peak detected 1: Peak not detected in correlation record, measurement is invalid
2	Signal Overflow Flag 0: Signal data has not overflowed 1: Signal data in correlation record has reached the maximum value before overflow. This occurs with a strong received signal strength
1	Reference Overflow Flag 0: Reference data has not overflowed 1: Reference data in correlation record has reached the maximum value before overflow. This occurs periodically
0	Busy Flag 0: Device is ready for new command 1: Device is busy taking a measurement

### 0x02

R/W	Name	Description	Initial Value
R/W	SIG_COUNT_VAL	Maximum acquisition count	0x80

Bit	Function
7:0	Maximum number of acquisitions during measurement

### 0x04

R/W	Name	Description	Initial Value
R/W	ACQ_CONFIG_REG	Acquisition mode control	0x08

Bit	Function
6	0: Enable reference process during measurement 1: Disable reference process during measurement
5	0: Use default delay for burst and free running mode 1: Use delay from MEASURE_DELAY (0x45) for burst and free running mode
4	0: Enable reference filter, averages 8 reference measurements for increased consistency 1: Disable reference filter
3	0: Enable measurement quick termination. Device will terminate distance measurement early if it anticipates that the signal peak in the correlation record will reach maximum value. 1: Disable measurement quick termination.
2	0: Use default reference acquisition count of 5. 1: Use reference acquisition count from REF_COUNT_VAL (0x12).
1:0	Mode Select Pin Function Control 00: Default PWM mode. Pull pin low to trigger measurement, device will respond with an active high output with a duration of 10us/cm. 01: Status output mode. Device will drive pin active high while busy. Can be used to interrupt host device. 10: Fixed delay PWM mode. Pulling pin low will not trigger a measurement. 11: Oscillator output mode. Nominal 31.25 kHz output. The accuracy of the silicon oscillator in the device is generally within 1% of nominal. This affects distance measurements proportionally and can be measured to apply a compensation factor.

### 0x09

R/W	Name	Description	Initial Value
R	VELOCITY	Velocity measurement output	--

Bit	Function
7:0	Velocity measurement output. The difference between the current measurement and the previous one, signed (2's complement) value in centimeters.

### 0x0c

R/W	Name	Description	Initial Value
R	PEAK_CORR	Peak value in correlation record	--

Bit	Function
7:0	The value of the highest peak in the correlation record.

### 0x0d

R/W	Name	Description	Initial Value
R	NOISE_PEAK	Correlation record noise floor	--

Bit	Function
7:0	A measure of the noise in the correlation record. Will be slightly above the third highest peak.

**0x0e**

R/W	Name	Description	Initial Value
R	SIGNAL_STRENGTH	Received signal strength	--

Bit	Function
7:0	Received signal strength calculated from the value of the highest peak in the correlation record and how many acquisitions were performed.

**0x0f**

R/W	Name	Description	Initial Value
R	FULL_DELAY_HIGH	Distance measurement high byte	--

Bit	Function
7:0	Distance measurement result in centimeters, high byte.

**0x10**

R/W	Name	Description	Initial Value
R	FULL_DELAY_LOW	Distance measurement low byte	--

Bit	Function
7:0	Distance measurement result in centimeters, low byte.

**0x11**

R/W	Name	Description	Initial Value
R/W	OUTER_LOOP_COUNT	Burst measurement count control	0x01

Bit	Function
7:0	0x00-0x01: One measurement per distance measurement command. 0x02-0xfe: Repetition count per distance measurement command. 0xff: Indefinite repetitions after initial distance measurement command. See ACQ_CONFIG_REG (0x04) and MEASURE_DELAY (0x45) for non-default automatic repetition delays.

**0x12**

R/W	Name	Description	Initial Value
R/W	REF_COUNT_VAL	Reference acquisition count	0x05

Bit	Function
7:0	Non-default number of reference acquisitions during measurement. ACQ_CONFIG_REG (0x04) bit 2 must be set.

**0x14**

R/W	Name	Description	Initial Value
R	LAST_DELAY_HIGH	Previous distance measurement high byte	--

Bit	Function
7:0	Previous distance measurement result in centimeters, high byte.

**0x15**

R/W	Name	Description	Initial Value
R	LAST_DELAY_LOW	Previous distance measurement low byte	--

Bit	Function
7:0	Previous distance measurement result in centimeters, low byte.

**0x16**

R/W	Name	Description	Initial Value
R	UNIT_ID_HIGH	Serial number high byte	Unique

Bit	Function
7:0	Unique serial number of device, high byte.

**0x17**

R/W	Name	Description	Initial Value
R	UNIT_ID_LOW	Serial number low byte	Unique

Bit	Function
7:0	Unique serial number of device, high byte.

**0x18**

R/W	Name	Description	Initial Value
W	I2C_ID_HIGH	Write serial number high byte for I2C address unlock	--

Bit	Function
7:0	Write the value in UNIT_ID_HIGH (0x16) here as part of enabling a non-default I2C address. See I2C_ID_LOW (0x19) and I2C_SEC_ADDR (0x1a).

**0x19**

R/W	Name	Description	Initial Value
W	I2C_ID_LOW	Write serial number low byte for I2C address unlock	--

Bit	Function
7:0	Write the value in UNIT_ID_LOW (0x17) here as part of enabling a non-default I2C address. See I2C_ID_HIGH (0x18) and I2C_SEC_ADDR (0x1a).

**0x1a**

R/W	Name	Description	Initial Value
R/W	I2C_SEC_ADDR	Write new I2C address after unlock	--

Bit	Function
7:0	Non-default I2C address. Available addresses are 7-bit values with a '0' in the least significant bit (even hexadecimal numbers). I2C_ID_HIGH (0x18) and I2C_ID_LOW (0x19) must have the correct value for the device to respond to the non-default I2C address.

**0x1c**

R/W	Name	Description	Initial Value
R/W	THRESHOLD_BYPASS	Peak detection threshold bypass	0x00

Bit	Function
7:0	0x00: Use default valid measurement detection algorithm based on the peak value, signal strength, and noise in the correlation record. 0x01-0xff: Set simple threshold for valid measurement detection. Values 0x20-0x60 generally perform well.

**0x1e**

R/W	Name	Description	Initial Value
R/W	I2C_CONFIG	Default address response control	0x00

Bit	Function
-----	----------

3	0: Device will respond to I2C address 0x62. Device will also respond to non-default address if configured successfully. See I2C_ID_HIGH (0x18), I2C_ID_LOW (0x19), and I2C_SEC_ADDR (0x1a). 1: Device will only respond to non-default I2C address. It is recommended to configure the non-default address first, then use the non-default address to write to this register, ensuring success.
---	--

#### 0x40

R/W	Name	Description	Initial Value
R/W	COMMAND	State command	--

Bit	Function
2:0	000: Test mode disable, resume normal operation 111: Test mode enable, allows download of correlation record Select correlation memory bank in ACQ_SETTINGS (0x5d) prior to enabling test mode. Once test mode is enabled, read CORR_DATA (0x52) and CORR_DATA_SIGN (0x53) in one transaction (read from 0xd2). The memory index is incremented automatically and successive reads produce sequential data.

#### 0x45

R/W	Name	Description	Initial Value
R/W	MEASURE_DELAY	Delay between automatic measurements	0x14

Bit	Function
7:0	Non-default delay after completion of measurement before automatic retrigger, in burst and continuous modes. ACQ_CONFIG_REG (0x04) bit 5 must be set. Value 0xc8 corresponds to 10 Hz repetition rate and 0x14 to roughly 100 Hz.

#### 0x4c

R/W	Name	Description	Initial Value
R	PEAK_BCK	Second largest peak value in correlation record	--

Bit	Function
7:0	The value of the second highest peak in the correlation record.

#### 0x52

R/W	Name	Description	Initial Value
R	CORR_DATA	Correlation record data low byte	--

Bit	Function
7:0	Correlation record data low byte. See CORR_DATA_SIGN (0x53), ACQ_SETTINGS (0x5d), and COMMAND (0x40).

#### 0x53

R/W	Name	Description	Initial Value
R	CORR_DATA_SIGN	Correlation record data high byte	--

Bit	Function
7:0	Correlation record data high byte. Correlation record data is a 2's complement 9-bit value, and must be sign extended to be formatted as a 16-bit 2's complement value. Thus when repacking the two bytes obtained for the I2C transaction, set the high byte to 0xff if the LSB of the high byte is one.

#### 0x5d

R/W	Name	Description	Initial Value
R/W	ACQ_SETTINGS	Correlation record memory bank select	--

Bit	Function
7:6	11: Access correlation memory bank. Write prior to test mode enable, see COMMAND (0x40).

#### 0x65

R/W	Name	Description	Initial Value
R/W	POWER_CONTROL	Power state control	0x80

Bit	Function
2	1: Device Sleep, wakes upon I2C transaction. Registers are reinitialized, wakeup time similar to full reset using enable pin. 0: Device awake
0	1: Disable receiver circuit 0: Enable receiver circuit. Receiver circuit stabilizes by the time a measurement can be performed.





## Frequently Asked Questions

### Must the device run on 5 Vdc? Can it run on 3.3 Vdc instead?

The device requires 5 Vdc to run properly, so this specification is recommended and supported.

### What is the spread of the laser beam?

At very close distances (less than 1 m) the beam diameter is about the size of the aperture (lens). For distances greater than 1 m, you can estimate the beam diameter using this equation:

Distance/100 = beam diameter at that distance (in whatever units you measured the distance).

The actual spread is ~8 milli-radians or ~1/2 degree.

### How do distance, target size, aspect, and reflectivity effect returned signal strength?

The device transmits a focused infrared beam that reflects off of a target, and a portion of that reflected signal returns to the receiver. The distance is calculated by taking the difference between the moment of signal transmission to the moment of signal reception. Successfully receiving a reflected signal is heavily influenced by several factors. These factors include:

- Target Distance

The relationship of distance (D) to returned signal strength is an inverse square. So, with increase in distance, returned signal strength decreases by  $1/D^2$  or the square root of the distance.

- Target Size

The relationship of a target's Cross Section (C) to returned signal strength is an inverse power of four. The device transmits a focused near-infrared laser beam that spreads at a rate of approximately  $0.5^\circ$  as distance increases. Up to 1 m it is approximately the size of the lens. Beyond 1 m, the approximate beam spread in degrees can be estimated by dividing the distance by 100, or ~8 milliradians. When the beam overfills (is larger than) the target, the signal returned decreases by  $1/C^4$  or the fourth root of the target's cross section.

- Aspect

The aspect of the target, or its orientation to the sensor, affects the observable cross section and, therefore, the amount of returned signal decreases as the aspect of the target varies from the normal.

- Reflectivity

Reflectivity characteristics of the target's surface also affect the amount of returned signal. In this case, we concern ourselves with reflectivity of near infrared wavelengths ("[How does the device work with reflective surfaces?](#)", page 12).

In summary, a small target can be very difficult to detect if it is distant, poorly reflective, and its aspect is away from the normal. In such cases, the returned signal strength may be improved by attaching infrared reflectors to the target, increasing the size of the target, modifying its aspect, or reducing distance from the sensor.

### How does the device work with reflective surfaces?

Reflective characteristics of an object's surface can be divided into three categories (in the real world, a combination of characteristics is typically present):

- Diffuse Reflective
- Specular
- Retro-reflective

#### Diffuse Reflective Surfaces

Purely diffuse surfaces are found on materials that have a textured quality that causes reflected energy to disperse uniformly. This tendency results in a relatively predictable percentage of the dispersed laser energy finding its way back to the device. As a result, these materials tend to read very well.

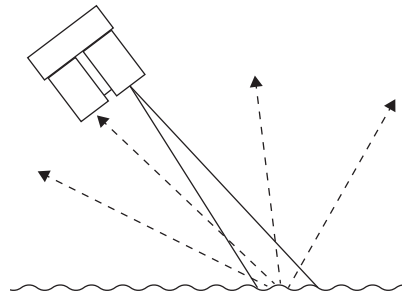

Materials that fall into this category are paper, matte walls, and granite. It is important to note that materials that fit into this category due to observed reflection at visible light wavelengths may exhibit unexpected results in other wavelengths. The near infrared range used by the device may detect them as nearly identical. For example, a black sheet of paper may reflect a nearly identical percentage of the infrared signal back to the receiver as a white sheet.

#### Specular Surfaces

Specular surfaces, are found on materials that have a smooth quality that reflect energy instead of dispersing it. It is difficult or impossible for the device to recognize the distance of many specular surfaces. Reflections off of specular surfaces tend to reflect with little dispersion which causes the reflected beam to remain small and, if not reflected directly back to the receiver, to miss the receiver altogether. The device may fail to detect a specular object in front of it unless viewed from the normal.

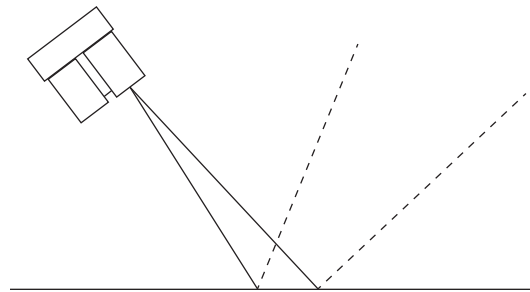

Examples of specular surfaces are mirrors and glass viewed off-axis.

## How does liquid affect the signal?

There are a few considerations to take into account if your application requires measuring distances to, or within, liquid:

- Reflectivity and other characteristics of the liquid itself
- Reflectivity characteristics of particles suspended in the liquid
- Turbidity
- Refractive characteristics of the liquid

Reflectivity of the liquid is important when measuring distance to the surface of a liquid or if measuring through liquid to the bottom of a container (“[How does the device work with reflective surfaces?](#)”, page 12).

It is important to note that measuring distance with the device depends on reflected energy from the transmitted signal being detected by the receiver in the sensor. For that reason, the surface condition of the liquid may play an important role in the overall reflectivity and detectability of the liquid. In the case of a flat, highly reflective liquid surface, the laser’s reflected energy may not disperse adequately to allow detection unless viewed from the normal. By contrast, small surface ripples may create enough dispersion of the reflected energy to allow detection of the liquid without the need to position the sensor so that the transmitted beam strikes the liquid’s surface from the normal.

Reflectivity of suspended particles is a characteristic that may help or hinder depending on the application.

Turbidity, or the clarity of a liquid created by the presence or absence of suspended particles, can similarly help or hinder measurement efforts. If the application requires detecting the surface of the liquid, then suspended particles may help by reflecting more of the transmitted beam back to the receiver, increasing detectability and permitting measurements to be taken.

It is important to note that, attempting to measure through suspended particles in a liquid will only be successful if the transmitted beam is allowed to reflect off of the desired target without first being absorbed or reflected by the suspended particles.

When the near infrared energy transmitted by the device transitions from the atmosphere to a liquid, the energy may be bent, or refracted, and absorbed in addition to being dispersed. The degree to which the transmitted beam is refracted and absorbed is defined by its refraction index. That being said, the most important criteria impacting successful measurement through a liquid is the amount of dispersion of the transmitted beam and whether any of the dispersed beam makes its way back to the receiver on the device.

Remember that electromagnetic energy travels slower through a liquid and may affect accuracy of the final measurement output.

For the latest free software updates (excluding map data) throughout the life of your Garmin products, visit the Garmin Web site at [www.garmin.com](http://www.garmin.com).



© 2016 Garmin Ltd. or its subsidiaries

Garmin International, Inc.  
1200 East 151<sup>st</sup> Street, Olathe, Kansas 66062, USA

Garmin (Europe) Ltd.  
Liberty House, Hounslow Business Park, Southampton, Hampshire, SO40 9LR UK

Garmin Corporation  
No. 68, Zhangshu 2<sup>nd</sup> Road, Xizhi Dist., New Taipei City, 221, Taiwan (R.O.C.)

[www.garmin.com](http://www.garmin.com)