



Chipsmall Limited consists of a professional team with an average of over 10 year of expertise in the distribution of electronic components. Based in Hongkong, we have already established firm and mutual-benefit business relationships with customers from,Europe,America and south Asia,supplying obsolete and hard-to-find components to meet their specific needs.

With the principle of “Quality Parts,Customers Priority,Honest Operation,and Considerate Service”,our business mainly focus on the distribution of electronic components. Line cards we deal with include Microchip,ALPS,ROHM,Xilinx,Pulse,ON,Everlight and Freescale. Main products comprise IC,Modules,Potentiometer,IC Socket,Relay,Connector.Our parts cover such applications as commercial,industrial, and automotives areas.

We are looking forward to setting up business relationship with you and hope to provide you with the best service and solution. Let us make a better world for our industry!



Contact us

Tel: +86-755-8981 8866 Fax: +86-755-8427 6832

Email & Skype: info@chipsmall.com Web: www.chipsmall.com

Address: A1208, Overseas Decoration Building, #122 Zhenhua RD., Futian, Shenzhen, China



TN9 Infrared Thermometer Module

User Manual

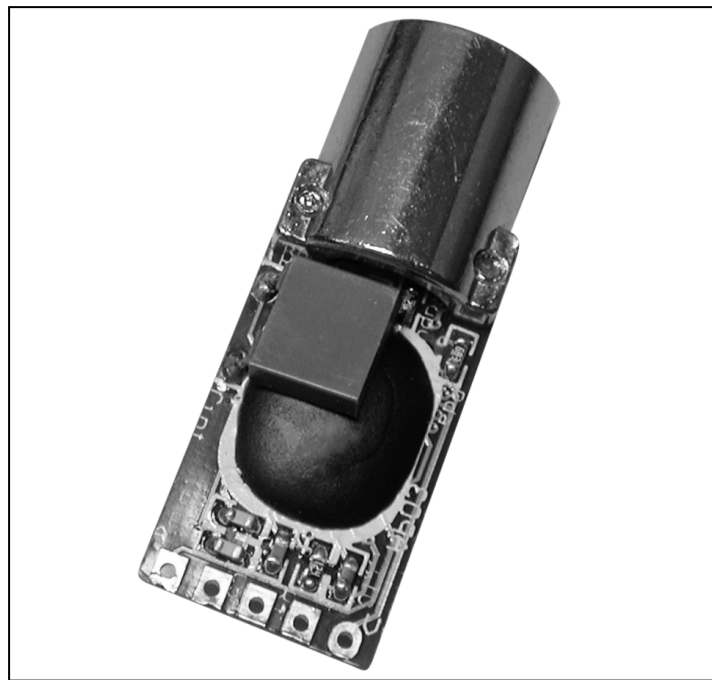

Contents

1 GENERAL DESCRIPTION	3
EDITION JULY 2006.....	3
2 THEORY OF OPERATION.....	4
2.1 PRINCIPLES OF OPERATION	4
2.2 FEATURES OF DESIGN	5
2.3 FIELD OF VIEW	6
2.4 EMISSIVITY	7
3 SPECIFICATION.....	8
3.1 ABSOLUTE MAXIMUM RATING.....	8
3.2 DC CHARACTERISTICS	8
3.3 MEASUREMENT SPECIFICATION	9
3.4 PIN ASSIGNMENT OF TN0; TN9	10
4 SERIAL OUTPUT	11
4.1 TYPICAL DIAGRAM	11
4.2 TIMING OF SPI	12
4.2.1 <i>Format of Message</i>	13
4.2.2 <i>Example</i>	13
4.2.3 <i>How to modify Emissivity? (How to write Emissivity into EEPROM)</i>	14
5 INTERFACE DEMO BOARD: HUB-D	15
6 INTERFACE PROGRAM FOR PC	16

1 General Description

This document describes the user guide of TNm Series (TN0; TN9).

Edition July 2006

Copyright:

All right reserved. Reproduction in any manner, in whole or in part is straightly prohibited without written permission of ZyTem.com. This information contained in this document is subject to change without notice.

Limited Warranty:

This data sheet contains information specific to products manufactured at the time of its publication, Contents herein do not constitute a warranty.

Trademark Acknowledgements:

All trademarks are the property of their respective owners.

2 Theory of Operation

2.1 Principles of Operation

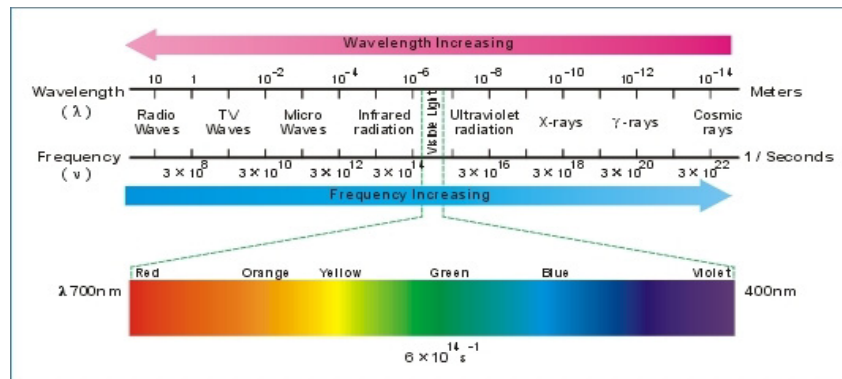

Fig 1. the Infrared Radiation Spectrum

Infrared, just like any light ray, is an Electromagnetic Radiation, with lower frequency (or longer wavelength) than visual light. Anything above absolute zero (-273.15 degrees Celsius or 0 degrees Kelvin), radiates in the infrared. Even ice cube, snow, your refrigerator emit infrared.

The **Stefan-Boltzmann Law**, where the total radiation energy is proportional to the fourth power of the absolute temperature and **Wien Displacement Law**, the product of the peak wavelength and the temperature is found to be a constant, are implemented in the TNm infrared thermometer module. The infrared radiation of measure target is collected by a infrared mirror through a IR filter of 5 or 8um cut in frequency to the infrared thermopile detector. The detector signal will be amplified and digitalize by the low noise and high linearity OP and AD convertor. The ambient temperature sensor(usually included in the same package as the thermopile detector) is set in the space near the optical system to detect the fast change of the ambient temperature. The signal processing section receives the signals from these temperature sensors to calculate the target surface temperature by a mathematical algorithm.

2.2 Features of Design

The TNm infrared thermometer module is specially designed for a high sensitivity, high accuracy, low noise and low power consumption. A number of design features contribute to the performance:

- MEMS thermopile detector and a high accurate ambient temperature compensation technics are used for the TNm infrared thermometer module.
- ZyTemp has developed a proprietary Infrared-System-On-Chip device that integrates all hardware items onto one IC. Using this innovative SoC technology, TNm infrared thermometer module has become a highly affordable and compact product.
- ZyTemp's products can faithfully withstand a thermal shock of 10degC/18degF. Our products are adept in maintaining accuracies under widely changing environmental conditions. For example, the errors from environmental changes of older IRTs can reach 1.6degC, requiring up to 30 minutes to stabilize, while ZyTemp's TNm error differential is only 0.7degC, needing only 7 minutes to restabilize.
- TNm products operate from a 3 Volt power supply, while many other older IRTs still require a 9 Volt supply.
- ZyTemp has maintained a NIST or National Measurement Laboratory traceable Temperature Primary Standard. All the TNm products are calibrated under traceable infrared standard sources. The calibration data and serial number are saved in a EEPROM on the module.

2.3 Field of View

What is D:S = 1:1
 This device has a D:S = 1:1
 Distance : Spot = 1:1

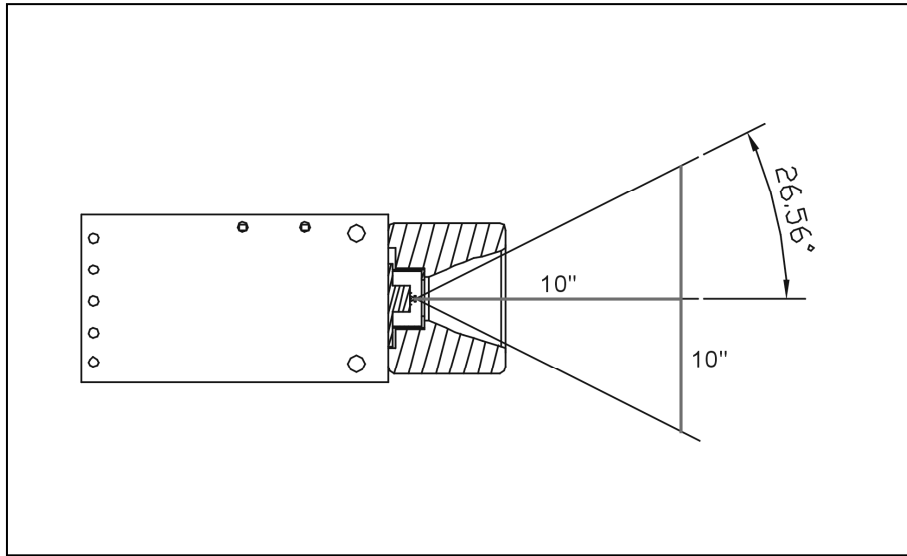

Fig 2. Field of View

When the Distance is 10 inch, then the measurement spot size is also 10 inch.
 When the Distance is 20 inch, then the measurement spot size is also 20 inch.
 In other words, the FOV(Field of View) is $26.6 \times 2 = 53.2$ degree

Beware the Vignette
 Good Design, No Vignette

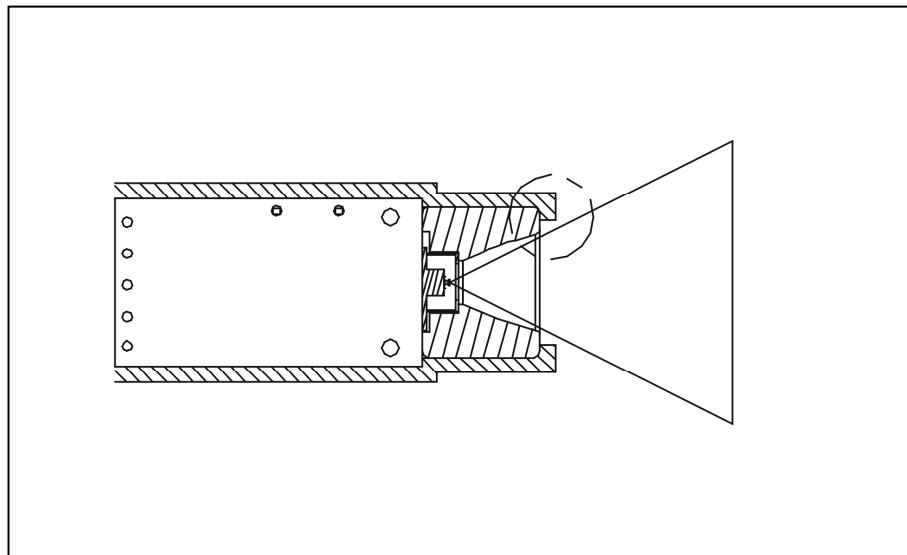

Fig 3. Good Design Field of View

Bad Design Vignette

The Sensor “see” the edge of the housing

So the measurement in fact is the averaging of the real target and the edge of housing.

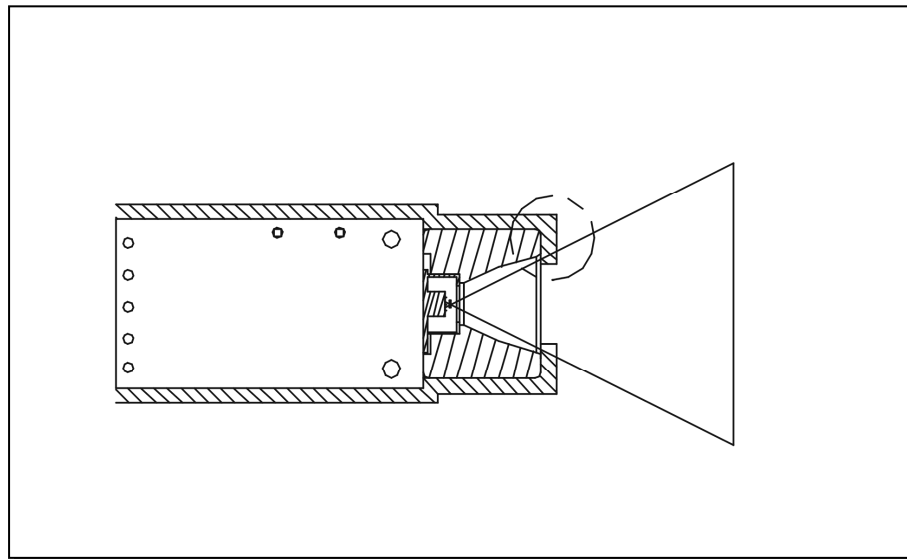

Fig 4. Bad Design Field of View

2.4 Emissivity

Understanding an object's emissivity, or its characteristic "radiance" is a critical component in the proper handling of infrared measurements. Concisely, emissivity is the ratio of radiation emitted by a surface or blackbody and its theoretical radiation predicted from **Planck's law**. A material's surface emissivity is measured by the amount of energy emitted when the surface is directly observed. There are many variables that affect a specific object's emissivity, such as the wavelength of interest, field of view, the geometric shape of the blackbody, and temperature. However, for the purposes and applications of the infrared thermometer user, a comprehensive table showing the emissivity at corresponding temperatures of various surfaces and objects is displayed. Please visit ZyTemp's website: <http://www.zytemp.com/tutorial/emissivity.asp> to check the emissivity of the materials of interested.

3 Specification

3.1 Absolute Maximum Rating

Characteristics	Symbol	Ratings
DC Supply Voltage	V_+	<7.0V
Input Voltage Range	V_{IN}	-0.5V to $V_+ + 0.5V$

Note: Stresses beyond those given in the Absolute Maximum Rating table may cause operational errors or damage to the device. For normal operational conditions see AC/DC Electrical Characteristics.

3.2 DC Characteristics

(VDD = 3.0V, T_A = 25°C)

Characteristics	Symbol	Limit			Unit	Test condition
		Min	Typ.	Max		
Operating Voltage	VDD	2.5	-	3.6	V	
Operating Current	I _{OP}	-	4	6	mA	VDD = 3.0V, F _{CPU} = 600KHz
Standby Current	I _{STBY}	-	2	3	μA	VDD = 3.0V
Input High Level	V _{IH}	2.0	-	-	V	VDD = 3.0V
Input Low Level	V _{IL}	-	-	0.8	V	VDD = 3.0V
Output High I	I _{OH}	-	-2.0	-	mA	VDD = 3.0V, V _{OH} = 2.4V
Output Sink I	I _{OL}	-	2.5	-	mA	VDD = 3.0V, V _{OH} = 0.8V

(VDD = 4.5V, T_A = 25°C)

Characteristics	Symbol	Limit			Unit	Test condition
		Min	Typ.	Max		
Operating Voltage	VDD	3.6	-	5.0	V	
Operating Current	I _{OP}	-	6	9	mA	VDD = 4.5V, F _{CPU} = 600KHz
Standby Current	I _{STBY}	-	3	4.5	μA	VDD = 4.5V
Input High Level	V _{IH}	3.0	-	-	μA	VDD = 4.5V
Input Low Level	V _{IL}	-	-	0.8	μA	VDD = 4.5V
Output High I	I _{OH}	-	-2.0	-	mA	VDD = 4.5V, V _{OH} = 3.5V
Output Sink I	I _{OL}	-	2.5	-	mA	VDD = 4.5V, V _{OL} = 0.8V

3.3 Measurement Specification

Measurement Range	-33~220°C / -27~428°F
Operating Range	-10~50°C / 14~122°F
Accuracy Tobj=15~35°C, Tamb=25°C	+/-0.6°C
Full Range Accuracy #AC	+/-2%, 2°C
Resolution	1/16°C=0.0625 (full range)
Response Time (90%)	1sec
D:S	1:1
Emissivity	0.01~1 step.01
Update Frequency	1.4Hz
Dimension	12x13.7x35mm
Wave Length	5um-14um
Weight	9g
Power Supply	3V or 5V Option

3.4 Pin Assignment of TN0; TN9

Warning: The Dimension in this drawing is for reference only.

For actual dimension, please download from

<http://www.ZyTemp.com/products/download/ExtDrawing.asp>

V: Vdd

G: GND

D: Data (Serial Data)

C: Clock (Serial Clock)

A: Action Pin (*pull low* to measure, *floating* while to Write Data into the IRT)

Note: TN0; TN9 has the same pin assignment.

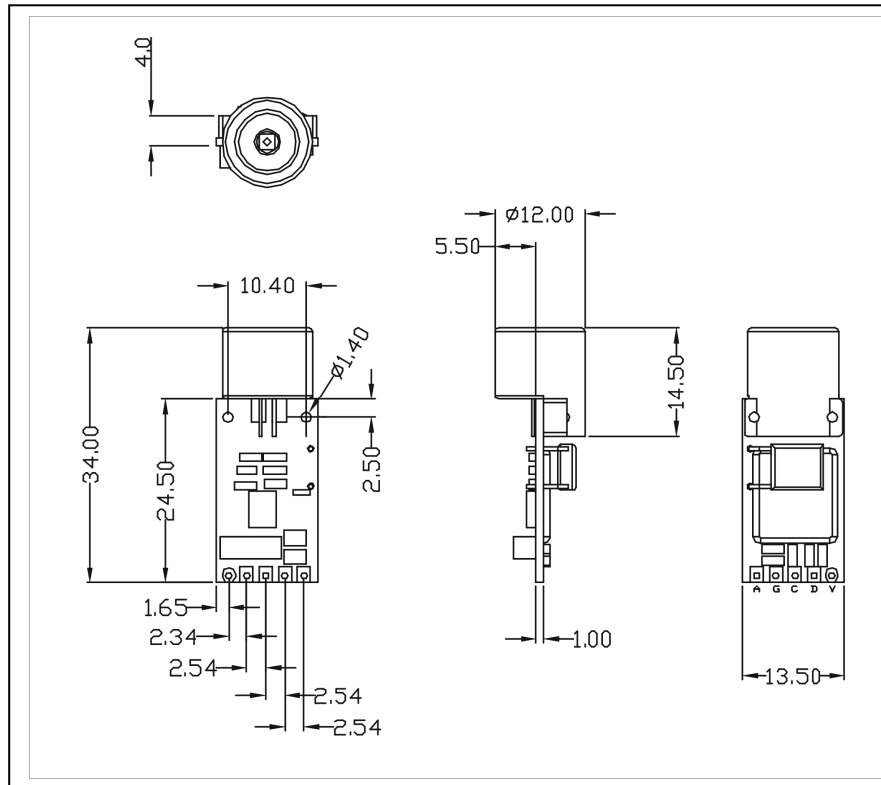

Fig 5. the Module External Drawing

4 Serial Output

4.1 Typical Diagram

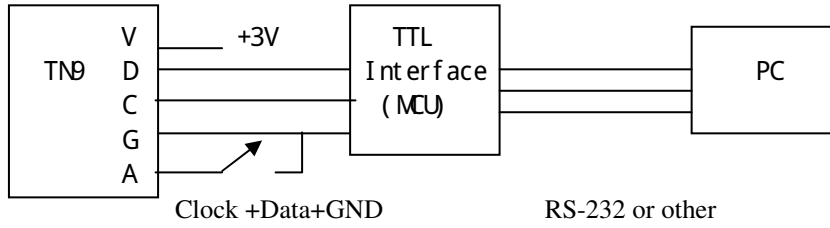

Fig 6. Typical Diagram

TN9 to TTL Interface (MCU)

V:Vcc

D:Data

C:Clock (2KHz)

G:GND

A:ActionKey (When Pull Low, the device will measure Tbb continuously.)

Note: Data Pin is High when there is no data out, Time Out > 2ms

4.2 Timing of SPI

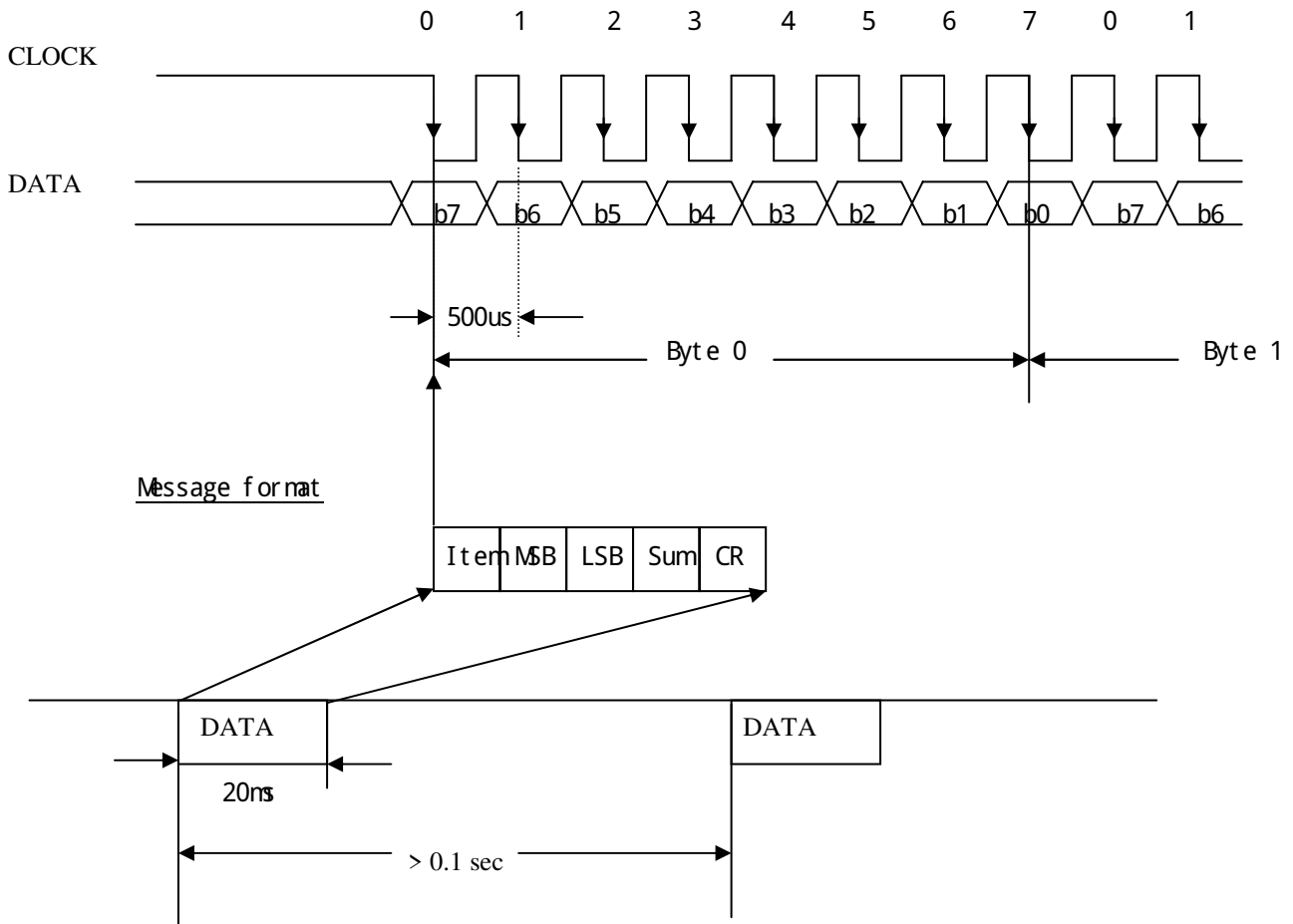

Fig 7. Timing of SPI

4.2.1 Format of Message

Item	MSB	LSB	Sum	CR
------	-----	-----	-----	----

Item “L”(4Ch): Tobj (Temperature of Obj)
 “f”(66h): Tamb (Ambient Temperature)
MSB 8 bit Data Msb
LSB 8 bit Data Lsb
Sum Item+MSB+LSB=SUM
CR 0Dh, End of the message

4.2.2 Example

1. Object Temperature(Tbb)

4C(hex)	14	2A	8A(hex)	0D(hex)
---------	----	----	---------	---------

Item 4Ch → “L” the item code of Object temperature
Data MSB 14h (“1” and “4” are ASCII char)
 LSB 2Ah (“2” and “A” are ASCII char)
 Real Temperature Value [Hex2Dec(142Ah)]/16-273.15= 49.475 °C
Sum CheckSum 4Ch+14h+2Ah=8AH (**Only Low Byte**)
CR 0Dh → ‘Carriage Return’ means End of Message

2. Ambiant Temperature(Tamb)

66(hex)	12	C3	3B(hex)	0D(hex)
---------	----	----	---------	---------

Item 66h → “f” the item code of Ambient temperature
Data MSB 12h (“1” and “2” are ASCII char)
 LSB C3h (“C” and “3” are ASCII char)
 Real Temperature Value [Hex2Dec(12C3h)]/16-273.15= 27.03 °C
Sum CheckSum 66h+12h+C3h=3Bh (**Only Low Byte**)
CR 0Dh → ‘Carriage Return’ means End of Message

4.2.3 How to modify the Emissivity? (How to write Emissivity into EEPROM)

Warning: misuse may result in EEPROM failure, this may destroy the calibration data. The device may become useless!

- 1) This Infrared Thermometer module is calibrated with Emissivity=0.95 defaultly. Most of Non-metal material has emissivity near to 0.95. But the infrared emissivity of normal metal is much lower and may have to modify the setting of the module for certain application.
- 2) The communication format is the same as reading data from the module:
ItemCode~HighByte~LowByte~Checksum(ItemCode+HighByte+LowByte)~CR,
total 40 clocks(& data).
Note: the sign "~" is not real data but only means "following by"
- 3) For writing Emissivity to TN9, the command is:
"S"(53h)~HighByte(Emissivity value)~04h~Checksum(ItemCode+HighByte+04h)~CR(0Dh)

Emissivity value = HighByte(hex)/100(dec),

For example: HighByte = 5F(hex)=95(dec) -> emissivity = 95(dec)/100(dec) = 0.95(dec).

Always keep the LowByte data = 04(hex).

Checksum value for this example: 53(hex)+5F(hex)+04(hex)=B7(hex)

- 4) **The trick for write data to TN9 is as below**
 - a. Action pin need to be floating while writing data to TN9.
 - b. As you know, TN9 will do routine data out by 40 clocks & datas with communication format.
After the 40th clock, TN9 will pull the CLK & DATA pin to weak high for waiting if there is External CPU want write data to TN9.
Please let External CPU start send 1st clock within the timing T1 after the 40th clock.
: 5ms < T1 < 10ms
 - c. The frequency of CLK should be 2KHz.
 - d. TN9 will latch the data at negative edge of CLK, so data should be ready before the negative edge of 1st writing clock.
- 5) For example,
Emissivity = 0.95 ==> "S" ~ 5F(hex) ~ 04(hex) ~ B7(hex) ~ CR
Emissivity = 0.80 ==> "S" ~ 50(hex) ~ 04(hex) ~ A7(hex) ~ CR
- 6) Finally, how do we know write emissivity success.
About 5 ms after you send CLK & DATA to TN9 completely.
TN9 should have 3 kinds of response.
 - a. TN9 will send out the same data which External CPU had written to TN9.
(We call this ECHO). That means write emissivity success.
 - b. TN9 will send out "S" ~ FF(hex) ~ FF(hex) ~ CheckSum("S" + FF + FF) ~ CR.
That means TN9 find data checksum error = a wrong data receiving.
TN9 will forget the data, and you need to re-write again.
 - c. TN9 have no response as above
That means TN9 don't get full 40 clocks.
Please check the clock & data which control by External CPU.
Especially, please make sure the T1 timing is right.

5 Interface Demo Board: Hub-D

General Description:

Hub-D is an Interface box with LCD, for TN series.

This Box can work as an interface between the IRTm(IRT Module) and PC. see Fig.A

“Hub_D” has a 2-column character type LCD Display, it can also work without the PC.

The Hub will show Tobj & Tamb (data from the IRTm) continuously.

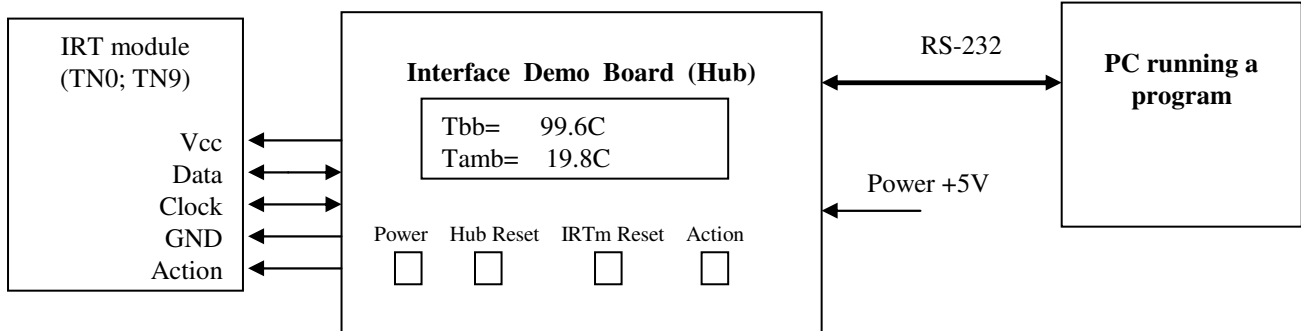

Fig 8. Typical Application of Hub

Model No:Hub-D

Program: TNmDB001.exe

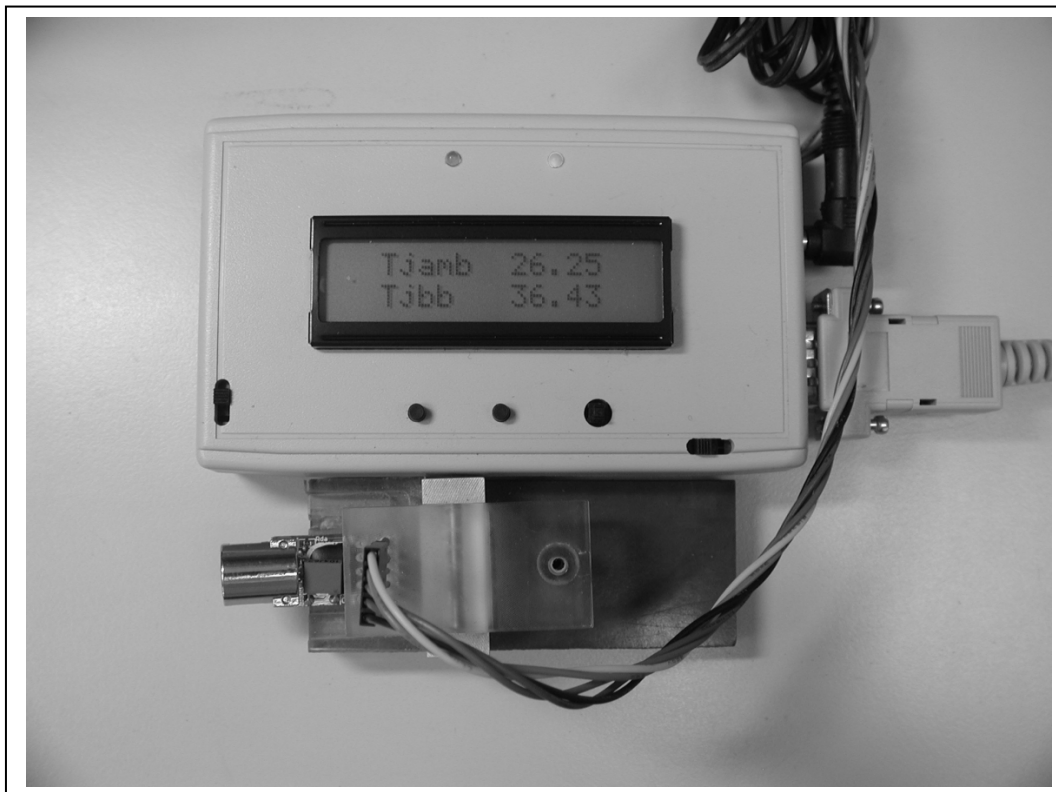

Fig 9. Hub-D

6 Interface Program for PC

Program: TNmDB001.exe

a Free version for demonstration can be download at <http://www.zytemp.com/download/default.asp>

- Running under a DOS window (in MS Windows environment)
- Must be used accompanied with HUB-D
- This program will show:
Tbb (Tobj) ; Tamb in degC;degF continuously
Status of IRT
- Modification of the Emissivity
- degC/degF unit change