



Chipsmall Limited consists of a professional team with an average of over 10 year of expertise in the distribution of electronic components. Based in Hongkong, we have already established firm and mutual-benefit business relationships with customers from,Europe,America and south Asia,supplying obsolete and hard-to-find components to meet their specific needs.

With the principle of "Quality Parts,Customers Priority,Honest Operation,and Considerate Service",our business mainly focus on the distribution of electronic components. Line cards we deal with include Microchip,ALPS,ROHM,Xilinx,Pulse,ON,Everlight and Freescale. Main products comprise IC,Modules,Potentiometer,IC Socket,Relay,Connector.Our parts cover such applications as commercial,industrial, and automotives areas.

We are looking forward to setting up business relationship with you and hope to provide you with the best service and solution. Let us make a better world for our industry!



Contact us

Tel: +86-755-8981 8866 Fax: +86-755-8427 6832

Email & Skype: info@chipsmall.com Web: www.chipsmall.com

Address: A1208, Overseas Decoration Building, #122 Zhenhua RD., Futian, Shenzhen, China



Turbidity sensor SKU: SEN0189



Contents

- [1 Introduction](#)
- [2 Specification](#)
- [3 Connection Diagram](#)
- [4 Examples](#)

Introduction

The turbidity sensor detects water quality by measuring the levels of turbidity. It uses light to detect suspended particles in water by measuring the light transmittance and scattering rate, which changes with the amount of total suspended solids (TSS) in water. As the TSS increases, the liquid turbidity level increases.

Turbidity sensors are used to measure water quality in rivers and streams, wastewater and effluent measurements, control instrumentation for settling ponds, sediment transport research and laboratory measurements.

This sensor provides analog and digital signal output modes. The threshold is adjustable when in digital signal mode. You can select the mode according to your MCU.



Note: The top of probe is not waterproof.

Specification

- Operating Voltage: 5V DC
- Operating Current: 40mA (MAX)
- Response Time : <500ms
- Insulation Resistance: 100M (Min)
- Output Method:
Analog output: 0-4.5V
Digital Output: High/Low level signal (you can adjust the threshold value by adjusting the potentiometer)
- Operating Temperature: 5°C~90°C
- Storage Temperature: -10°C~90°C
- Weight: 30g
- Adapter Dimensions: 38mm*28mm*10mm/1.5inches *1.1inches*0.4inches

Connection Diagram

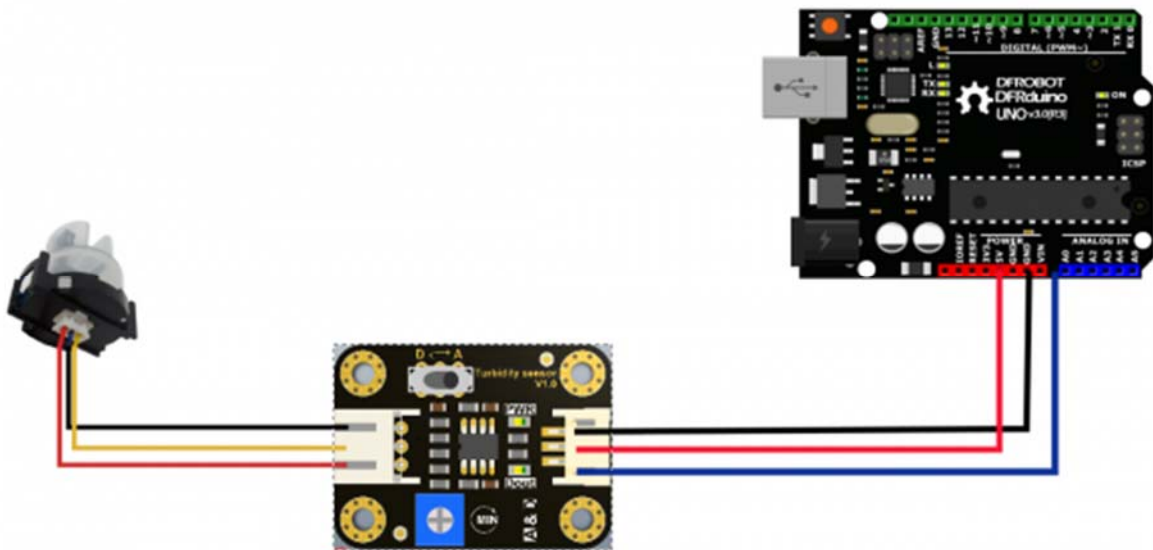

Interface Description:

1. "D/A" Output Signal Switch
1. "A": Analog Signal Output, the output value will decrease when in liquids with a high turbidity
2. "D": Digital Signal Output, high and low levels, which can be adjusted by the threshold potentiometer
2. Threshold Potentiometer: you can change the trigger condition by adjusting the threshold potentiometer in digital signal mode.

Examples

Here are two examples:

Example 1 uses Analog output mode

Example 2 uses Digital output mode

Example 1

```
void setup() {  
    Serial.begin(9600); //Baud rate: 9600  
}  
  
void loop() {  
    int sensorValue = analogRead(A0); // read the input on analog pin 0:  
    float voltage = sensorValue * (5.0 / 1024.0); // Convert the analog read  
    ing (which goes from 0 - 1023) to a voltage (0 - 5V):  
    Serial.println(voltage); // print out the value you read:  
    delay(500);  
}
```

Example 2

```
int ledPin = 13; // Connect an LED on pin 13, or use the on  
board one  
  
int sensor_in = 2; // Connect turbidity sensor to Digital  
Pin 2
```

```

void setup(){
  pinMode(ledPin, OUTPUT);      // Set ledPin to output mode
  pinMode(sensor_in, INPUT);    //Set the turbidity sensor pin to input
  mode
}

void loop(){
  if(digitalRead(sensor_in)==LOW){      //read sensor signal
    digitalWrite(ledPin, HIGH);  // if sensor is LOW, then turn on
  }else{
    digitalWrite(ledPin, LOW);    // if sensor is HIGH, then turn off
    the led
  }
}

```

This is a reference chart for the mapping from the output voltage to the NTU according to different temperature. e.g. If you leave the sensor in the pure water, that is NTU < 0.5, it should output "4.1±0.3V" when temperature is 10~50°C.

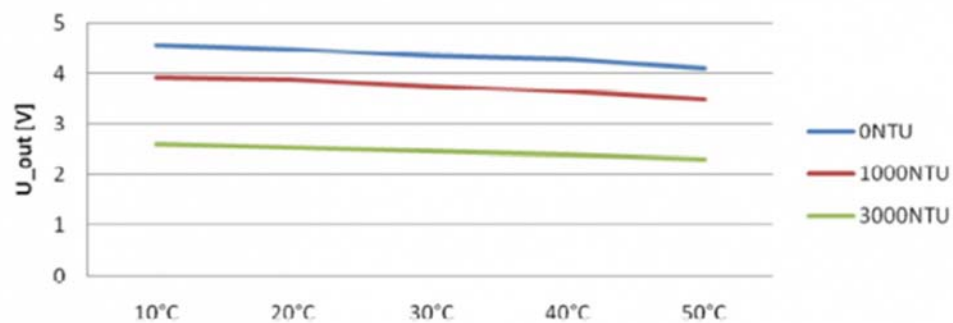

characteristic curve "Voltage ----Temperature

Note: In the diagram, the unit measuring turbidity is shown as NTU, also it is known as JTU (Jackson Turbidity Unit), 1JTU = 1NTU = 1 mg/L. Refer to Turbidity wikipedia