



Chipsmall Limited consists of a professional team with an average of over 10 year of expertise in the distribution of electronic components. Based in Hongkong, we have already established firm and mutual-benefit business relationships with customers from,Europe,America and south Asia,supplying obsolete and hard-to-find components to meet their specific needs.

With the principle of “Quality Parts,Customers Priority,Honest Operation,and Considerate Service”,our business mainly focus on the distribution of electronic components. Line cards we deal with include Microchip,ALPS,ROHM,Xilinx,Pulse,ON,Everlight and Freescale. Main products comprise IC,Modules,Potentiometer,IC Socket,Relay,Connector.Our parts cover such applications as commercial,industrial, and automotives areas.

We are looking forward to setting up business relationship with you and hope to provide you with the best service and solution. Let us make a better world for our industry!



Contact us

Tel: +86-755-8981 8866 Fax: +86-755-8427 6832

Email & Skype: info@chipsmall.com Web: www.chipsmall.com

Address: A1208, Overseas Decoration Building, #122 Zhenhua RD., Futian, Shenzhen, China





MicroWave Sensor SKU: SEN0192

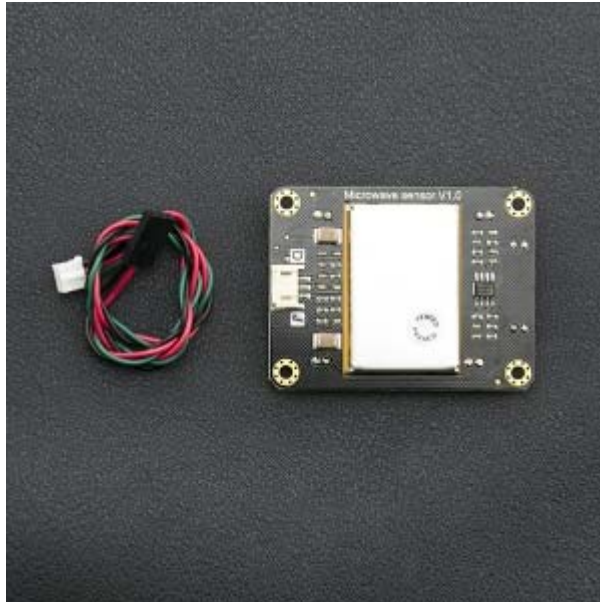

Microwave Sensor

Contents

- [1 Introduction](#)
- [2 Specification](#)
- [3 Board Overview](#)
- [4 Sensor Module Description](#)
 - [4.1 Antenna Description](#)
 - [4.2 Signal Processing](#)
 - [4.3 Signal Detection Range](#)
 - [4.4 Install](#)
 - [4.5 Indicators and Output Status](#)
 - [4.6 Distance Adjustment](#)
- [5 Comparison with IR Sensor](#)
- [6 Tutorial](#)
 - [6.1 Requirements](#)
 - [6.2 Connection Diagram](#)
 - [6.3 Sample Code](#)
- [7 FAQ](#)

Introduction

The microwave sensor uses [doppler radar](#) to detect moving objects using microwaves. This differs from the method used by a regular infrared (IR) sensor as the microwave is sensitive to a variety of objects that can reflect microwaves, and its sensor readings are not affected by the ambient

temperature.

This type of sensor is widely used in industrial, transportation and civil applications such as measuring a vehicle's speed, measuring liquid levels, automatic door motion detection, automatic washing, production line material detection, car reversing sensors, etc.

The microwave detection method has the following advantages compared with other detection methods:

1. Able to detect objects without physical contact
2. Readings not affected by temperature, humidity, noise, air, dust or light - suitable for harsh environments
3. Strong resistance to radio frequency interference
4. Low output, not harmful to the human body
5. Microwaves have a wide detection range and velocity equal to the speed of light
6. Supports non-life-class object detection

Specification

- Working Voltage: 5V + 0.25V
- Working Current(CW): 60mA max., 37mA typical
- Size: 48.5x63mm
- Emission:
 - Detection Distance: 2-16M continuously adjustable
 - Emission Frequency: 10.525 GHz
 - Precision Frequency Setting: 3MHz
 - Output Power (Minimum): 13dBm EIRP
 - Harmonic Emission: < -10dBm
 - Average Current (5%DC): 2mA typ.
 - Pulse Width (Min.): 5uSec
 - Load Cycle (Min.): 1%
- Reception:
 - Sensitivity (10dB S/N ratio) 3Hz to 80Hz bandwidth: -86dBm
 - 3Hz to 80Hz Bandwidth Clutter: 10uV
 - Antenna Gain: 8dBi
 - Vertical 3dB Beam Width: 36 degrees
 - Level 3dB Beam Width: 72 degrees

Board Overview

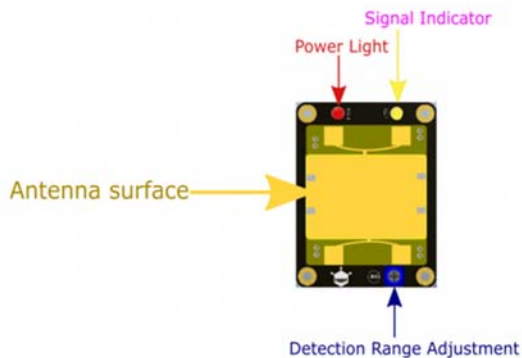

Color	Function Description
Green	Signal Line
Red	Power+ (VCC)
Black	Power- (GND)

Sensor Module Description

Antenna Description

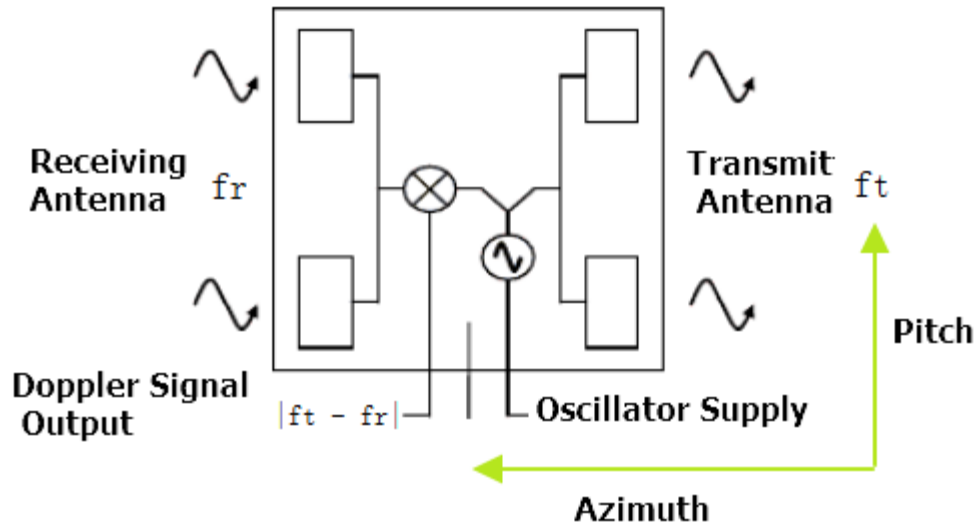

Signal Processing

The following diagram demonstrates the working principle of the sensor module. It works by amplifying a tiny signal which is received by the microwave sensor, and then through the comparison circuit it converts the signal into a square signal with a digital output of 0 or 1 which an Arduino or other micro controller can easily handle.

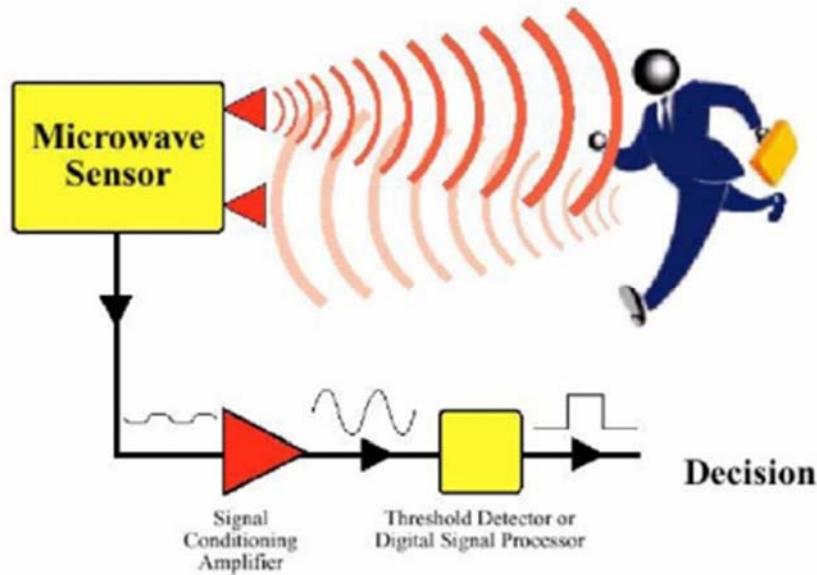

Signal Detection Range

Detection Angle: The angle of detection is 72 degrees with the antenna in a parallel direction (azimuth) The vertical (pitch) direction of the antenna is 36 degrees.

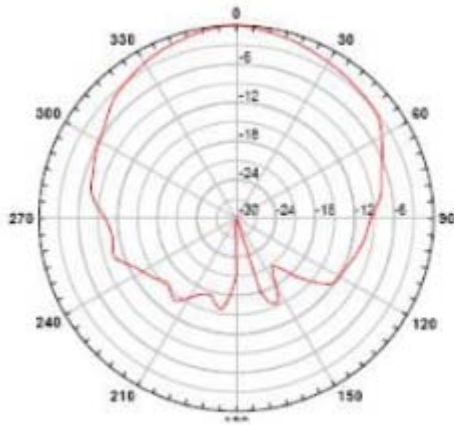

Azimuth

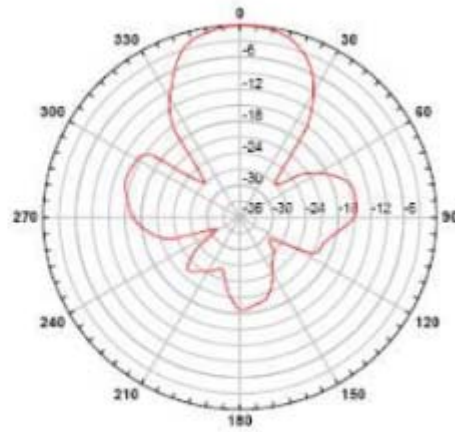

Pitch

Install

Microwaves can penetrate through walls. So sometimes it is inaccuracies when microwaves penetrate to outside walls and detect moving objects in non-target areas. Be sure to choose an installation location to avoid this!

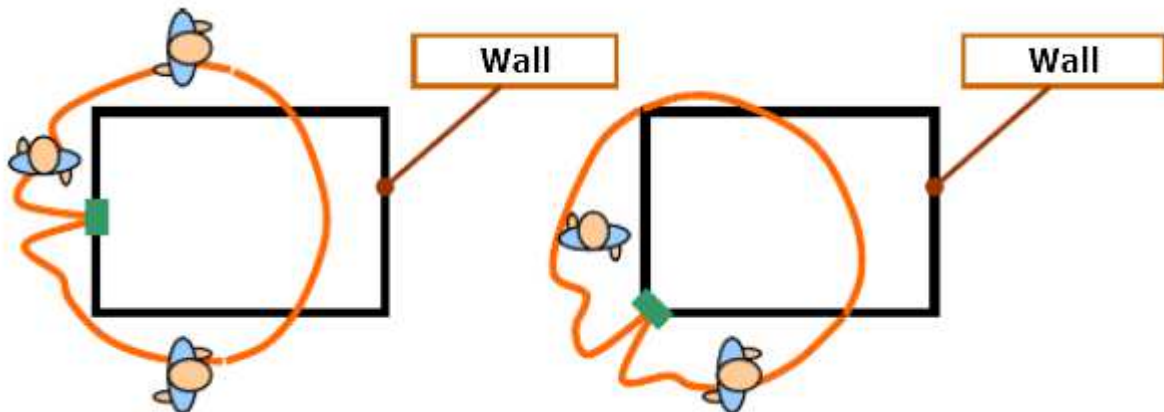

Indicators and Output Status

When the microwave sensor does not detect moving objects, the indicator LED remains off. When the sensor detects moving objects, the LED will turn on and the output level will be change from HIGH to LOW. The LED will automatically turn off about after 0.5s and the output level will change from LOW to HIGH. If the microwave sensor detects continuously moving objects the LED will keep flashing on and off. The output level will fluctuate between HIGH and LOW until the object stops moving.

Distance Adjustment

The microwave sensor has a distance range of 2-16m. The detection distance can be adjusted using the potentiometer. If it is turned in the direction on MIN, the detection distance decreases. If it is turned in the opposite direction, the range increases.

Comparison with IR Sensor

	Microwave Sensor	IR Sensor
Trigger Mode	Movement	Infrared Reflection
Temperature Influence	No Influence	Over 40 degrees C can inhibit function
Object Penetration	Able to penetrate any non-metallic object	Unable to penetrate
Ambient Environmental Requirements	No requirements	Dusty or brightly lit environments can inhibit function
Working Life	more than 100,000 hours	about 1000 hours
Stability	Very reliable and stable	Induction distance will shorten over time

Tutorial

Requirements

- **Hardware**
Arduino UNO (or similar) x1
Microwave sensor x1
3PIN digital cable x1
- **Software**
Arduino IDE V1.6.5 [Click to Download Arduino IDE from Arduino®](#)

Connection Diagram

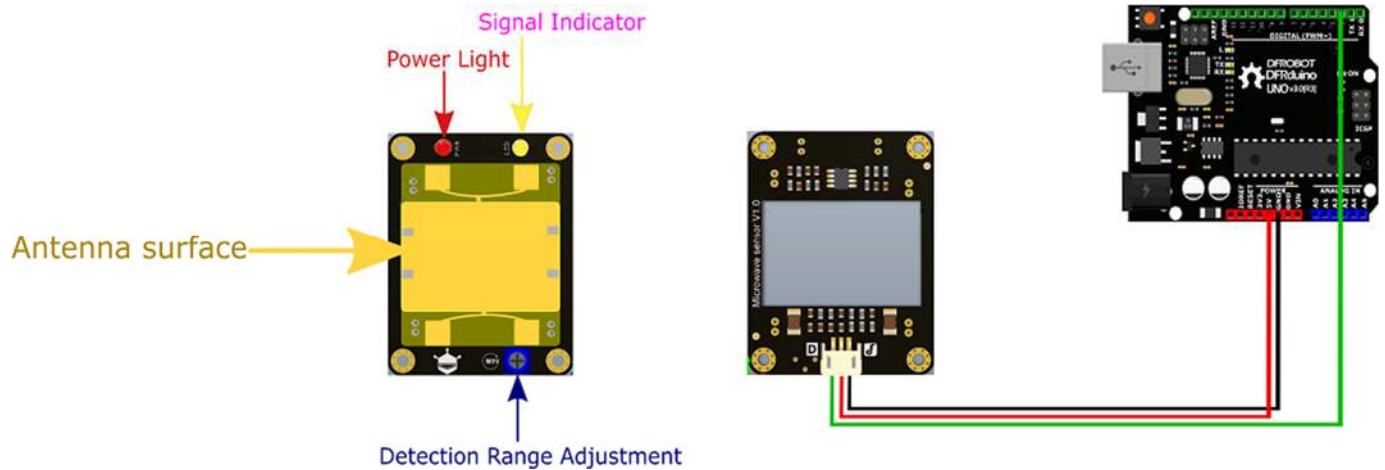

 Align the antenna surface towards the area you need to detect

Note: The sensor can be adjusted continuously within the range of 2-16m. Turn the potentiometer in the direction of MIN and the detection range decreases. Turn the potentiometer in the opposite direction and the detection range increases.

Sample Code

Please download [MsTimer2 library](#) first. Here is tutorial about [Library installation](#).

```

1 #include <MsTimer2.h>           //Timer interrupt function library
2 int pbIn = 0;                   // Define interrupt 0 that is digital pin
2
3 int ledOut = 13;                // Define the indicator LED pin digital p
in 13
4 int number=0;                  //Interrupt times
5 volatile int state = LOW;       // Defines the indicator LED state, the
default is not bright
6
7 void setup()
8 {
9     Serial.begin(9600);

```

```

10     pinMode(ledOut, OUTPUT);//
11     attachInterrupt(pbIn, stateChange, FALLING); // Set the interrupt fun
ction, interrupt pin is digital pin D2, interrupt service function is stateCh
ange (), when the D2 power change from high to low , the trigger interrupt.
12     MsTimer2::set(1000, Handle); // Set the timer interrupt function, run
ning once Handle() function per 1000ms
13     MsTimer2::start();//Start timer interrupt function
14
15 }
16
17 void loop()
18 {
19     Serial.println(number); // Printing the number of times of interruption, w
hich is convenient for debugging.
20     delay(1);
21     if(state == HIGH) //When a moving object is detected, the ledout is a
utomatically closed after the light 2S, the next trigger can be carried out,
and No need to reset. Convenient debugging.
22     {
23         delay(2000);
24         state = LOW;
25         digitalWrite(ledOut, state); //turn off led
26     }
27
28 }
29
30
31 void stateChange() //Interrupt service function
32 {
33     number++; //Interrupted once, the number +1
34
35 }
36
37 void Handle() //Timer service function
38 {

```



```
39     if(number>1) //If in the set of the interrupt time the number more th
an 1 times, then means have detect moving objects,This value can be adjusted
according to the actual situation, which is equivalent to adjust the threshol
d of detection speed of moving objects.
40         {
41             state = HIGH;
42             digitalWrite(ledOut, state); //light led
43             number=0; //Cleare the number, so that it does not af
fect the next trigger
44         }
45     else
46         number=0; //If in the setting of the interrupt time, the n
umber of the interrupt is not reached the threshold value, it is not detected
the moving objects, Cleare the number.
47 }
```

FAQ

There are no questions about this product yet. If you have any problems or suggestions, you are welcome to email us or post on the DFRobot forum!

For any questions/advice/cool ideas to share, please visit the [DFRobot Forum](#)