



Chipsmall Limited consists of a professional team with an average of over 10 year of expertise in the distribution of electronic components. Based in Hongkong, we have already established firm and mutual-benefit business relationships with customers from,Europe,America and south Asia,supplying obsolete and hard-to-find components to meet their specific needs.

With the principle of “Quality Parts,Customers Priority,Honest Operation,and Considerate Service”,our business mainly focus on the distribution of electronic components. Line cards we deal with include Microchip,ALPS,ROHM,Xilinx,Pulse,ON,Everlight and Freescale. Main products comprise IC,Modules,Potentiometer,IC Socket,Relay,Connector.Our parts cover such applications as commercial,industrial, and automotives areas.

We are looking forward to setting up business relationship with you and hope to provide you with the best service and solution. Let us make a better world for our industry!



Contact us

Tel: +86-755-8981 8866 Fax: +86-755-8427 6832

Email & Skype: info@chipsmall.com Web: www.chipsmall.com

Address: A1208, Overseas Decoration Building, #122 Zhenhua RD., Futian, Shenzhen, China





TFmini LiDAR Module

1. Product Overview

Coupled with unique optical and electrical design, the product is based upon ToF (Time of Flight) and adopts 850nm infrared light source so as to measure distance with stability, precision, high sensitivity, and high speed.

The product is built with algorithms adapted to various application environments so as to offer excellent distance measurement performances with low cost and small size. The product adopts multiple adjustable configurations for flexible use by the client, which is better to satisfy the end-users' demand.

2. Technical Specifications and Parameters

Table 1 Key Characteristic Parameters of TFmini

	Description	Parameter value
Product performance	Operating Range(Indoor)	0.3m~12m ^①
	Measurement accuracy	±4cm@ (0.3-6m) ^②
		±6cm@ (6m-12m)
	Range resolution	5mm
	Frequency	100Hz
	Default unit of distance output	cm
	Light sensitivity	70klux
Operating temperature	0~60°C	
Optical parameters	Light source	LED
	Wavelength	850nm
	Receiving half angle	1.15°
	Transmitting half angle	1.5°
Electrical parameters	Power supply voltage	5V
	Average current	≤120mA
	Average power	≤0.6W
	Peak current	800mA
	Communication level	LVTTTL (3.3V)
Others	Wiring length	10cm
	Material of enclosure	ABS+PC
	Weight	4.7g
	Storage temperature	-20°C ~75°C



- ① This data is based on the indoor test with the standard white board (90% reflectivity) as the detection object.
- ② Maybe some errors of $\pm 6\text{cm}$ occurs due to the switchover of different distance modes within 0.3-2m.

3. Product Appearance and Structure

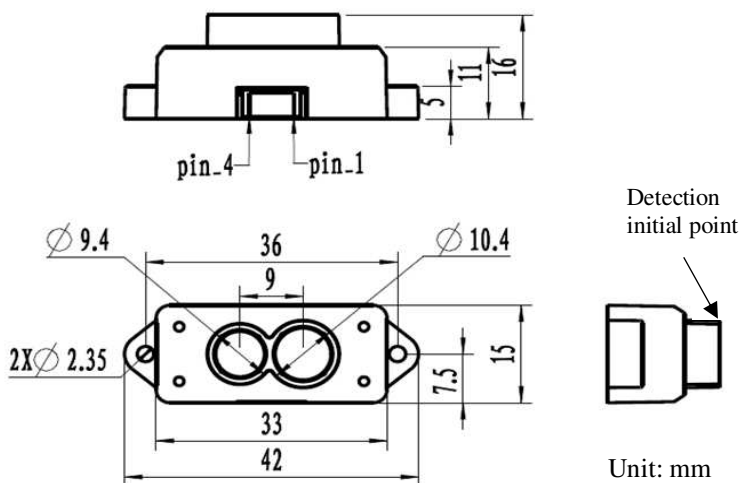

Figure 1 Dimensional Drawing of TFmini

4. Definition of Product's Connector

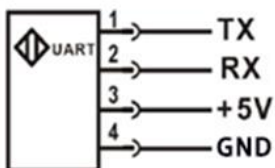

Figure 2 Line Sequence Diagram of TFmini

TFmini is equipped with the connector of GH1.25-4p type. The line sequence is shown in Figure 2. The positions of the product pins are shown in Figure 1.

5. Communication Protocol and Data Format

Table 2 Product Communication Protocol

Communication interface	UART
Default baud rate	115200 (adjustable)
Data bit	8
Stop bit	1
Parity check	None

Table 3 Standard Data Code Format and Description

Byte0-1	Byte2	Byte3	Byte4	Byte5	Byte6	Byte7	Byte8
0x59 59	Dist_L	Dist_H	Strength_L	Strength_H	Mode	0x00	Checksum



Data code explanation	
Byte0-1	0x59 59, frame header, same for each frame
Byte2-3	Dist represents the distance detection values, with the data format in little-endian.
Byte4-5	Strength, signal strength at current distance ,with the data format in little-endian,
Byte6	Mode, distance mode, represented respectively by 02 (short distance) and 07 (long distance), automatically switchable by default.
Byte7	Spare byte, 00 by default
Byte8	Checksum is the low 8 bits of the cumulative sum of the numbers of the first 8 bytes.

6. Configurable Parameters

6.1 General Parameter Configuration commands

Before modifying the product configuration, input 42 57 02 00 00 00 01 02 to enter configuration mode, and then input the relevant configuration commands in Table 4. After completing the configuration , input the 42 57 02 00 00 00 00 02 to quit the configuration mode.

Table 4 List of General Parameter Configuration commands

Configurable items	List of commands	Description	Default
Output data format	42 57 02 00 00 00 01 06	Standard format, as shown in Table 3	√
	42 57 02 00 00 00 04 06	“Pixhawk” data format	/
Data output period	42 57 02 00 EE FF 00 07	EE FF: setting of output period (ms) it must be the integral multiple of 10ms	10ms/ 100Hz
Unit of distance	42 57 02 00 00 00 00 1A	Output unit of distance data is mm	/
	42 57 02 00 00 00 01 1A	Output unit of distance data is cm	√
Detection Pattern	42 57 02 00 00 00 00 14	Automatic detection pattern	√
	42 57 02 00 00 00 01 14	Fix detection pattern	/
Distance mode	42 57 02 00 00 00 02 11	Short distance mode, applicable for 0-5m	/
	42 57 02 00 00 00 07 11	Long distance mode, applicable for 1-12m	/
Setting of range limit	42 57 02 00 00 00 00 19	Range limit disabled	/
	42 57 02 00 EE FF 01 19	Range limit enabled EE FF: threshold of ranging limit (mm)	Range limit 12m
lower limit of signal strength threshold	42 57 02 00 EE 00 00 20	EE: setting of the lower limit of signal strength threshold. If the real signal is lower than the set threshold, “FF FF” will be output as the distance value which means invalid.	Lower threshold 20(DEC)
upper limit of signal strength threshold	42 57 02 00 EE FF GG 21	EE FF: setting of the upper limit of signal strength threshold GG: output distance value (cm)	/





6.2 Advanced Parameter Configuration commands

Advanced parameter configuration commands. Input 42 57 02 00 00 00 01 02 to enter the configuration mode, and then input the relative command as the Table 5.

Table 5 Special Parameter Configuration and Description

Configurable items	List of commands	Description	Default
Setting of baud rate	42 57 02 00 00 00 GG 08	The baud rate corresponding to GG is shown in Table 6.	115200
Setting of trigger sources	42 57 02 00 00 00 01 40	Internal trigger, 100Hz as default	√
	42 57 02 00 00 00 00 40	External trigger	/
External trigger setting	42 57 02 00 00 00 00 41	command for one single measurement	
Reset	42 57 02 00 FF FF FF FF	All settings are reset to the default	/

Table 6 Corresponding List of Baud Rate Settings

GG	0x00	0x01	0x02	0x03	0x04	0x05	0x06
Baud rate	9600	14400	19200	38400	56000	57600	115200
GG	0x07	0x08	0x09	0x0a	0x0b	0x0c	/
Baud rate	128000	230400	256000	460800	500000	512000	/

7. Remote Upgrade

TFmini supports remote upgrade. The user can obtain the following information by Upgrade PC software of TFmini.

- ① Program version No. ② Product serial No.

The user is kindly required to select product program version depending upon the actual demands. For details, refer to the Product Manual of TFmini.

8. Product Certification

