



Chipsmall Limited consists of a professional team with an average of over 10 year of expertise in the distribution of electronic components. Based in Hongkong, we have already established firm and mutual-benefit business relationships with customers from,Europe,America and south Asia,supplying obsolete and hard-to-find components to meet their specific needs.

With the principle of “Quality Parts,Customers Priority,Honest Operation,and Considerate Service”,our business mainly focus on the distribution of electronic components. Line cards we deal with include Microchip,ALPS,ROHM,Xilinx,Pulse,ON,Everlight and Freescale. Main products comprise IC,Modules,Potentiometer,IC Socket,Relay,Connector.Our parts cover such applications as commercial,industrial, and automotives areas.

We are looking forward to setting up business relationship with you and hope to provide you with the best service and solution. Let us make a better world for our industry!



## Contact us

Tel: +86-755-8981 8866 Fax: +86-755-8427 6832

Email & Skype: info@chipsmall.com Web: www.chipsmall.com

Address: A1208, Overseas Decoration Building, #122 Zhenhua RD., Futian, Shenzhen, China





# Sensor Evaluation Kit

ROHM-SENSEKIT1-EVK-101  
SENSEKIT2-EVK-101

# USER MANUAL

# Contents

<b>1. General Information and Introduction .....</b>	<b>3</b>
1.1 Introduction .....	3
1.2 Quick Start Guide .....	3
1.3. Supported Sensor Products .....	4
<b>2. Base Board Overview .....</b>	<b>5</b>
2.1. Hardware .....	5
2.2. Software .....	9
<b>3. Breakout Board Overview .....</b>	<b>10</b>
3.1. Hall Sensor Breakout Board.....	10
3.2. Ambient Light Sensor Breakout Boards .....	12
3.2.1. BH1620FVC Breakout Board .....	12
3.2.2. BH1721FVC Breakout Board .....	14
3.3 UV Sensor Breakout Board .....	16
3.3.1. ML8511 Breakout Board .....	16
3.4. MEMS Sensor Breakout Board .....	18
3.4.1. KMX61 Breakout Board .....	18
3.5. Temperature Sensor Breakout Board .....	21
3.5.1. BDE0600G Breakout Board .....	21
<b>Appendix A: Programming the Base Board Instructions .....</b>	<b>23</b>

## 1. General Information and Introduction

### 1.1 Introduction

The Sensor Evaluation Kit is designed to test the functional operation of various sensor types. It includes one Base Board and several Breakout Boards. The Base Board is a controller board with a LAPIS MCU. The Breakout boards are sensor boards containing different types of sensor ICs.

This guide will help you understand how to connect Breakout Boards to the Base Board. It will also show how the Base Board obtains data from sensors, and converts and displays the results on a computer screen.

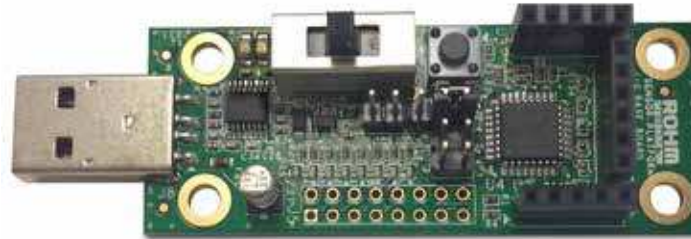

Figure 1: Sensor Evaluation Kit

### 1.2 Quick Start Guide

**Step 1:** Check to make sure the latest drivers are installed on your computer for communicating with the Base Board (LAPIS MCU) via USB. If not, please go to <http://www.ftdichip.com/Support/Documents/InstallGuides.htm> to access the driver files.

**Step 2:** Verify that the jumper settings are set as follows:

- Power Selection Switch (J1) is in the VBUS position (position 3).
- Reset Selection Header (J2) is in the USR\_RST position (connect pins 1 and 2).

**Step 3:** Plug the Sensor Breakout Board into the Base Board.

**Step 4:** Connect the Base Board + Breakout Board to the computer via USB cable.

**Step 5:** Run the Serial Terminal tool (PuTTY), configure PuTTY to run in Serial mode with a data rate of 9600bps. The output data will be displayed on the terminal screen. If no output is displayed, please go to Appendix A: Programming the Base Board Instructions to program/re-program the Base Board.

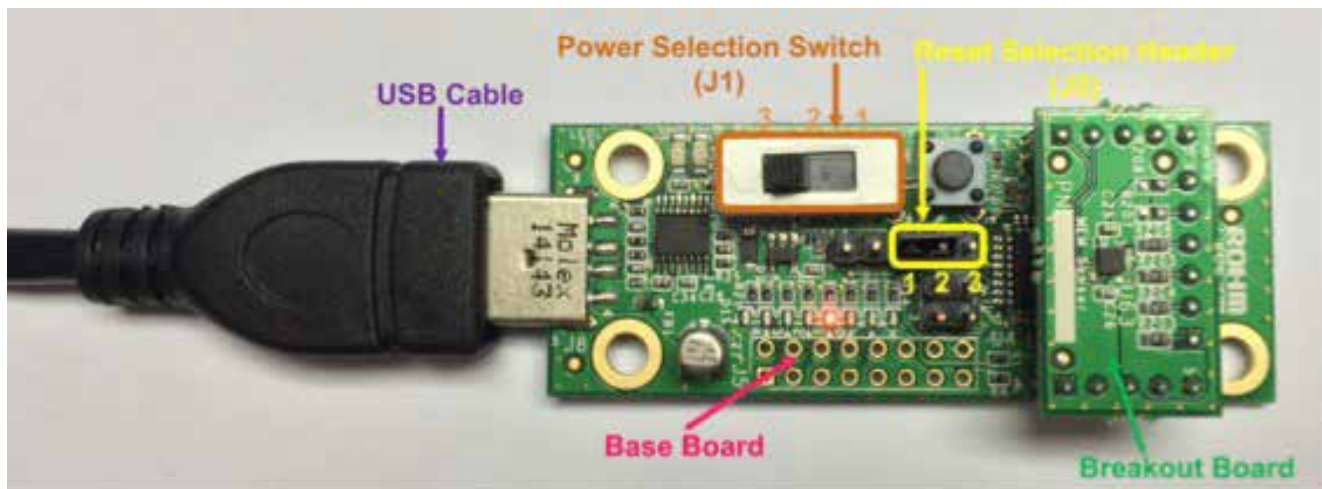

Figure 2: Base Board and Breakout Board Connection

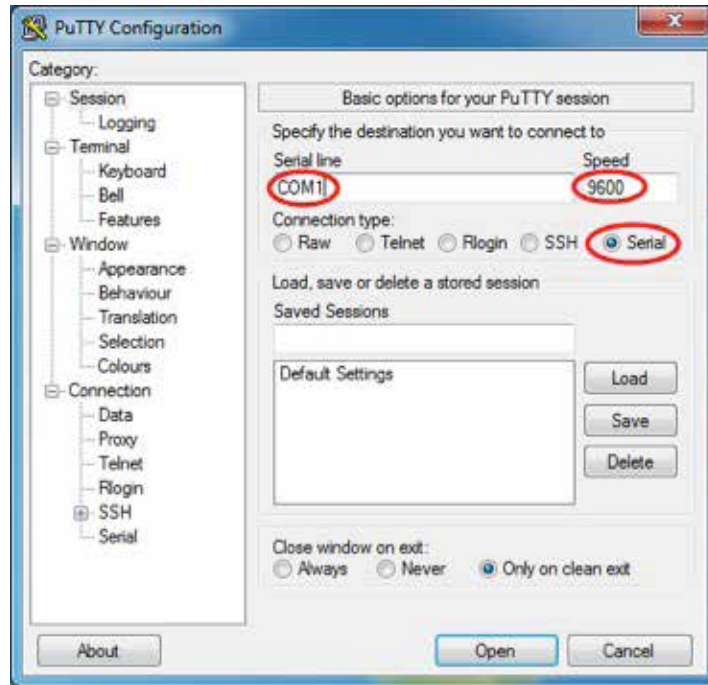

Figure 3: Pu TTy Configuration

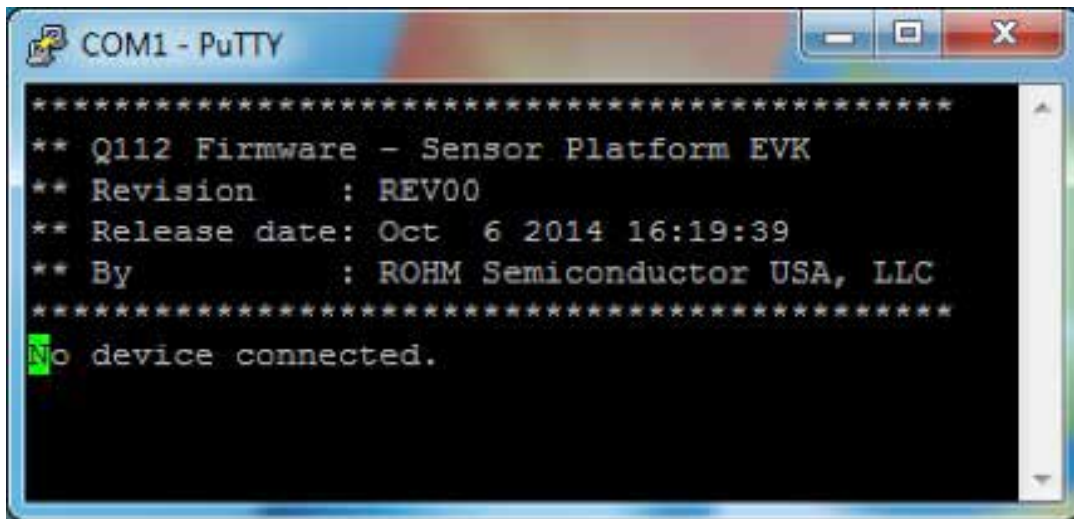

Figure 4: Base Board Sample Output (without Breakout Board)

### 1.3. Supported Sensor Products

Part Number	Sensor Type	Sensor Control Code
BU52011HFV	Hall Sensor	2
BH1620FVC	Ambient Light Sensor	5
BH1721FVC		8
ML8511	UV Sensor	10
KMX61	MEMs	16
BDE0600G	Temperature Sensor	22

Table 1: Supported Sensor Products

## 2. Base Board Overview

### 2.1. Hardware

The block diagram of the Base Board is shown in Figure 5. LAPIS Semiconductor's ML610Q112 MCU is used to interface with the Breakout Board via Sensor Interface Headers and with the PC via the UART-to-USB IC FT230XS-R.

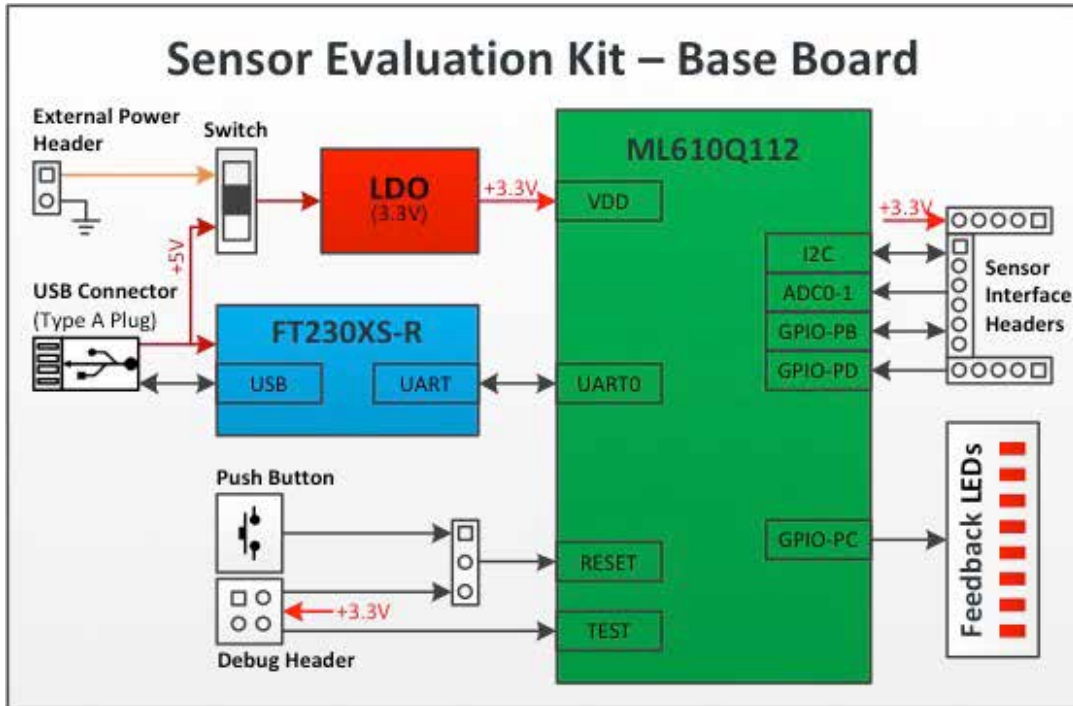

Figure 5: Base Board Hardware Block Diagram

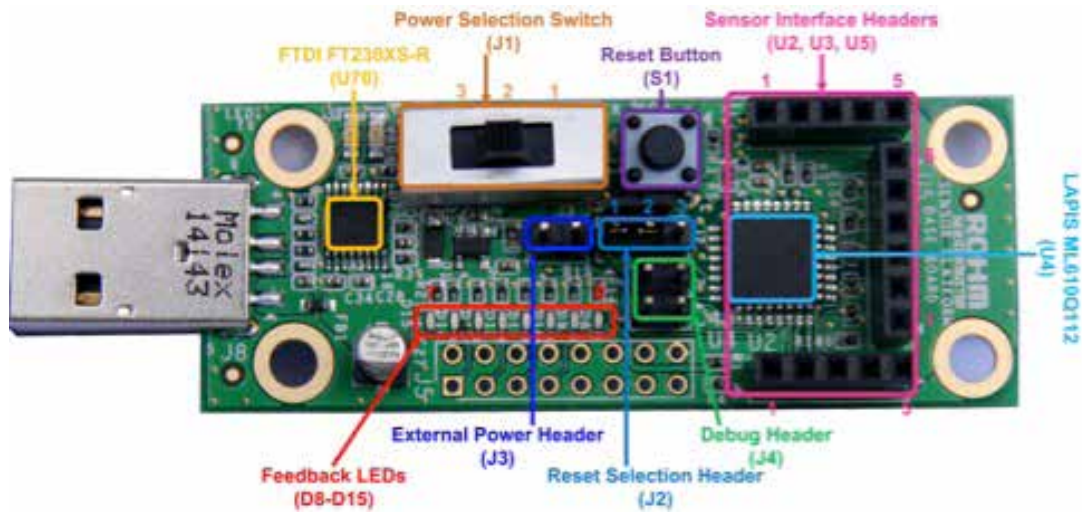

Figure 6: Base Board (Top View)

Designator	Position	Description
J1	1 (EXT_PWR)	External Power Source selected
	2 (OPEN)	No Power Source selected
	3 (VBUS)	VBUS Source selected
J2	2-1 (USR_RST)	User Reset selected
	2-3 (nE_RST)	nanoEASE Reset selected

Table 2: Base Board - Jumper/Switch Configurations

The ML610Q112 is a high-performance 8bit CMOS microcontroller that incorporates a variety of peripheral circuits, such as timers, PWM/UART/I<sup>2</sup>C bus interface (master/slave), synchronous serial port, voltage level supervisor, analog comparators, and 10-bit successive approximation type A/D converter, around an 8bit nX-U8/100 CPU. The nX-U8/100 is capable of efficient instruction execution at 1 instruction per clock cycle via parallel processing and pipeline architecture. The Flash ROM installed as program memory and on-chip debugging function enable program debugging and programming on the customer's board.

## Q112 MICROCONTROLLER

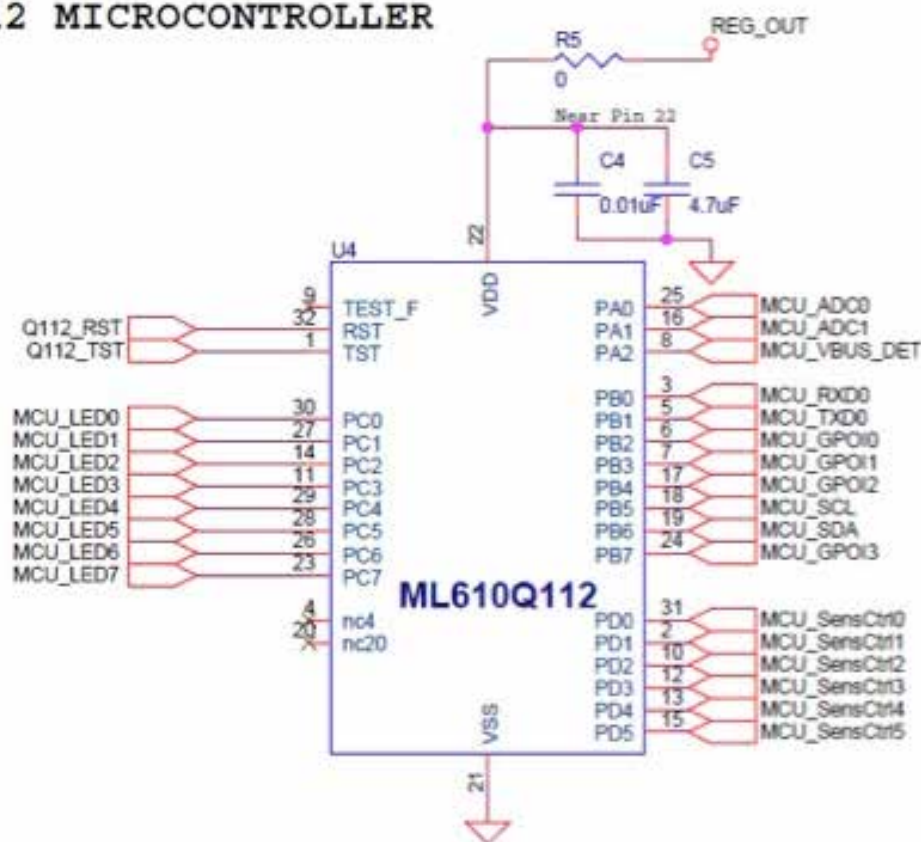

Figure 7: Base Board - Q112 MCU Schematic

The Base Board is powered by the VBUS pin in the USB connector or an external power source connected via Header J3. Switch J1 is used to select the power source.

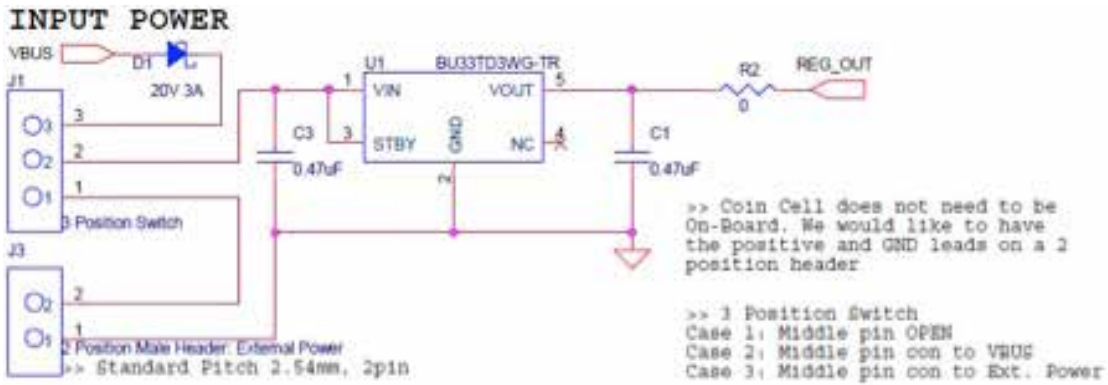

Figure 8: Base Board - Power Supply Schematic

The debugging function of ML610Q112 is extremely useful. You will be able to single-step through your code to quickly find problems and solutions as well as set breakpoints and create and save watch lists of variables to help you better understand what is going on inside your code. To manually reset the micro using Button S1, move J2 to the USR\_RST position.

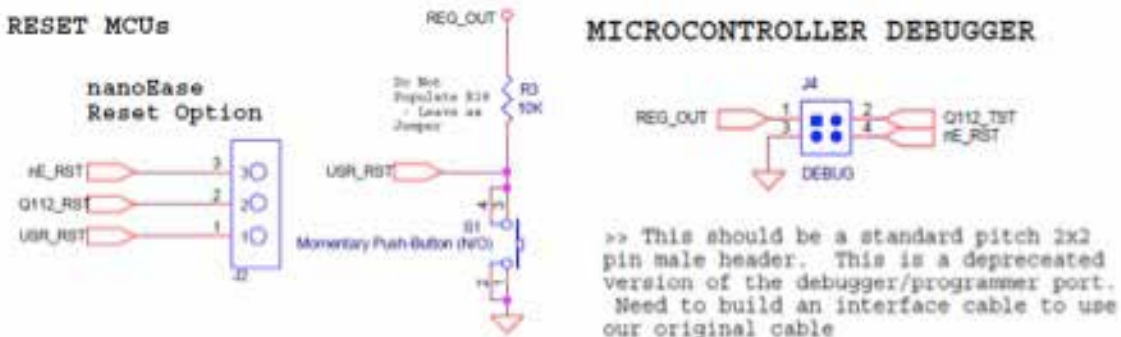

Figure 9: Base Board - Reset and Debugger Schematic

The Sensor Interface Headers

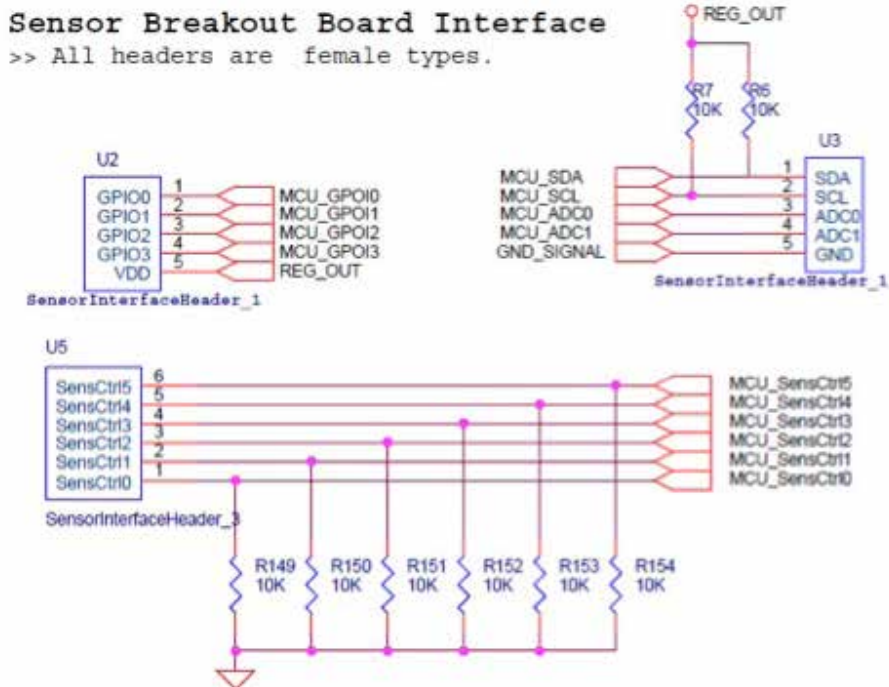
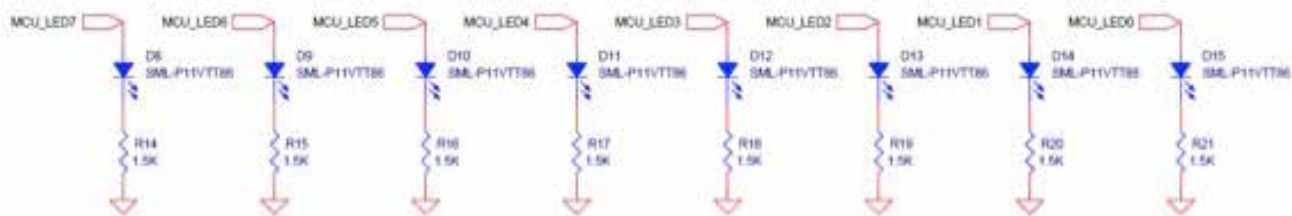

Figure 10: Base Board - Sensor Interface Schematic



The feedback LEDs

**Standalone Mode LED Feedback Section**



>> Using ROHM Red PicoLEDs

Figure 11: Base Board - Feedback LED Schematic

The UART to USB Block

**USB to serial UART interface**

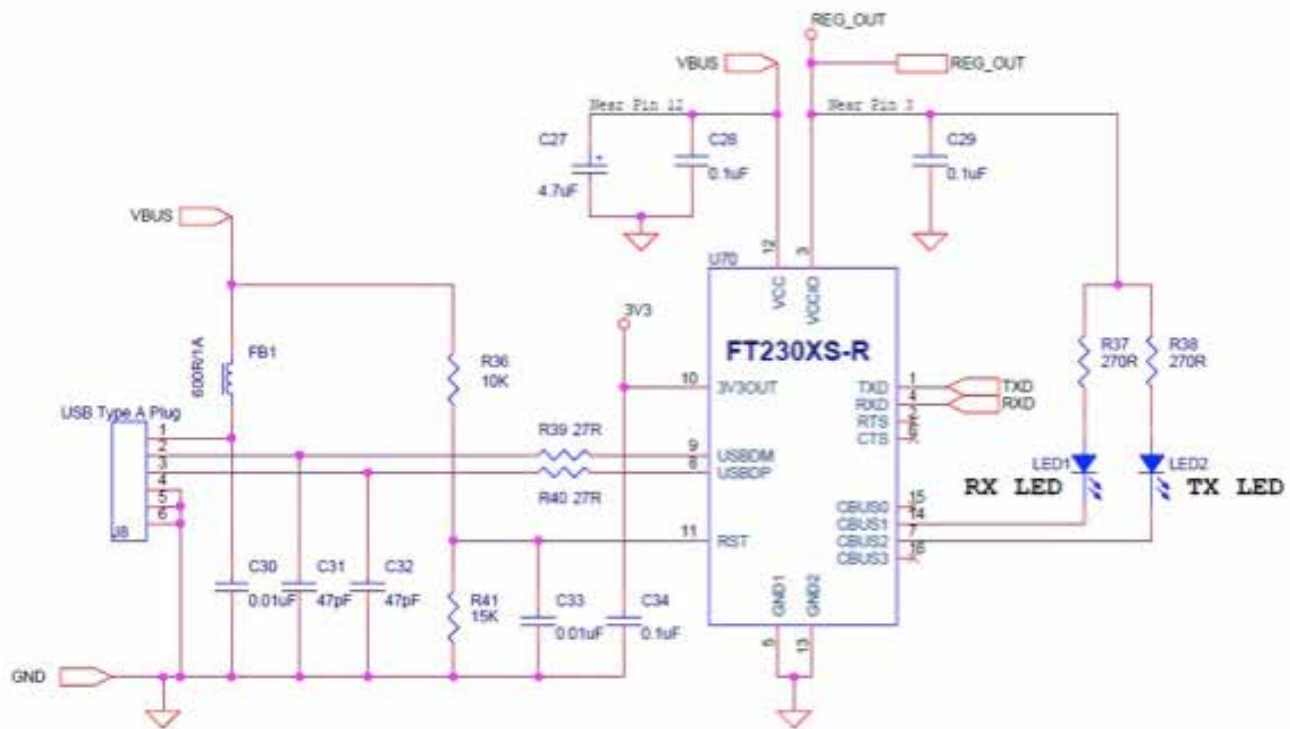

>> FT230XS-R RST => Active Low

Figure 12: Base Board - USB to UART Schematic

## 2.2. Software

The source code of the Base Board software can be downloaded from <https://github.com/ROHMUSDC/ROHMSensorPlatformEVK>

The flow diagram of the Base Board software is shown in *Figure 13*. The “Sensor Control” value is the input data from the PD port of ML610Q112. This value is used to detect the type of Breakout Board connected to the Base Board (refer to Table 1).

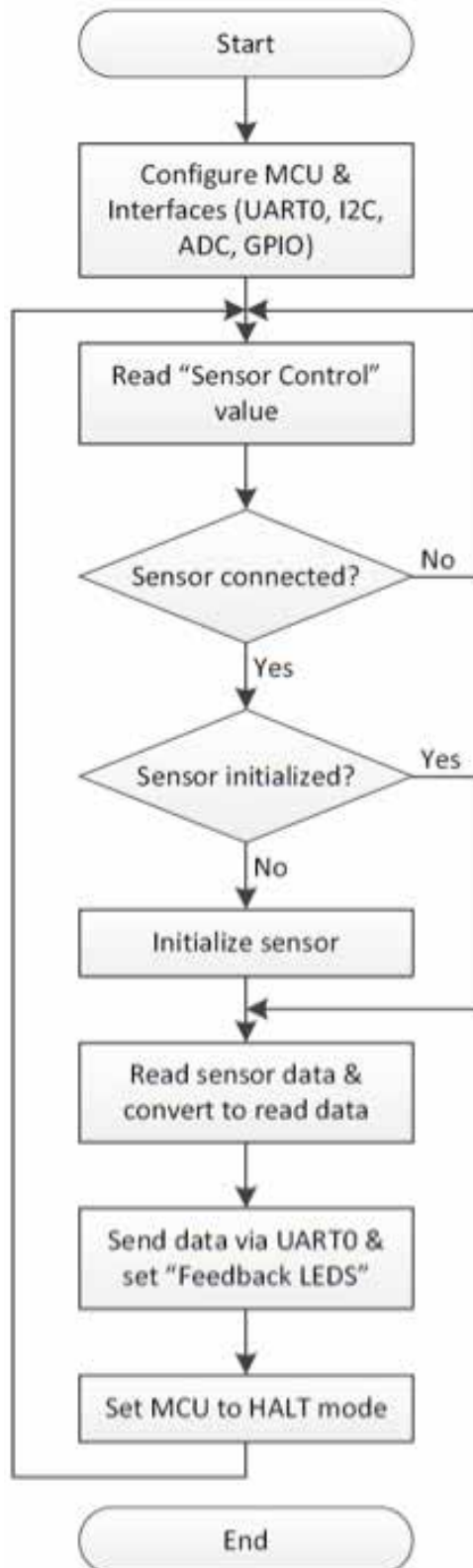

Figure 13: Base Board - Software Flow Diagram

### 3. Breakout Board Overview

#### 3.1. Hall Sensor Breakout Board

##### 3.1.1. BU52011HFV Breakout Board

The BU52011HFV Breakout Board provides a simple environment to quickly evaluate the performance of the BU52011HFV sensor. The BU52011HFV features magnetic switches that can operate both the S- and N-poles, upon which the output goes from High to Low.

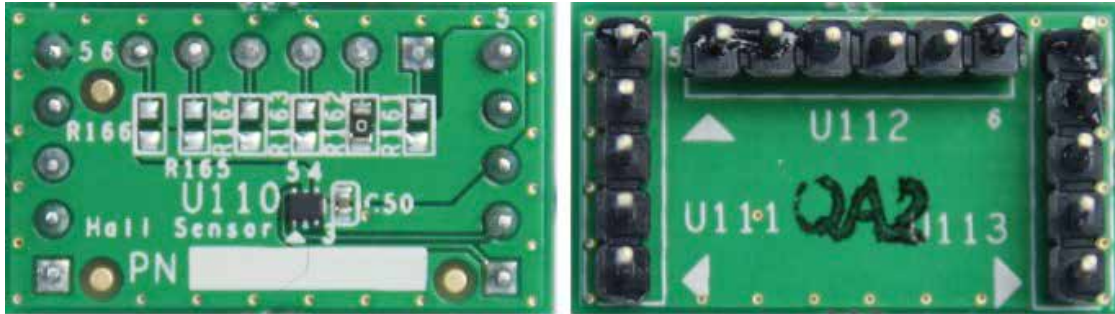

Figure 14: BU52011HFV Breakout Board (Top and Bottom Views)

The block diagram and schematic of the BU52011HFV Breakout Board are shown in Figures 15 and 16, respectively. Resistors R161 to R166 are used to set the Sensor Control value for the board. Pin 5 (OUT1) of the BU52011HFV is connected to the Base Board via Pin 1 (GPIO0) of Sensor Interface Header 1.

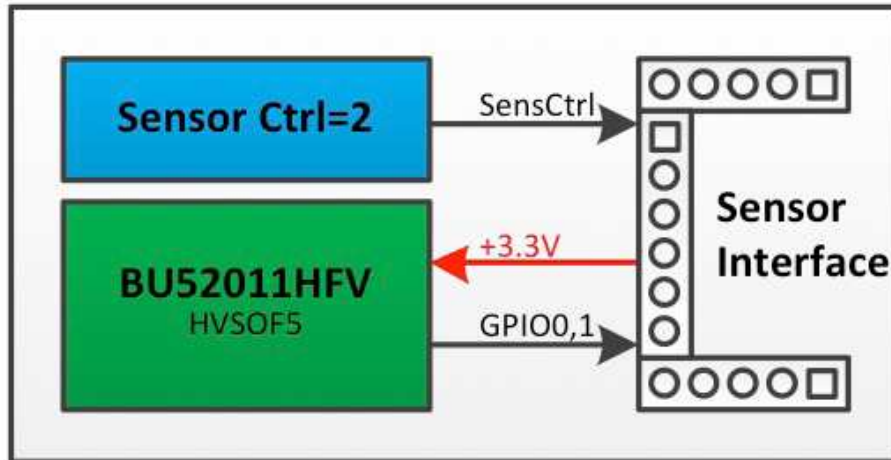

Figure 15: BU52011HFV Breakout Board Block Diagram

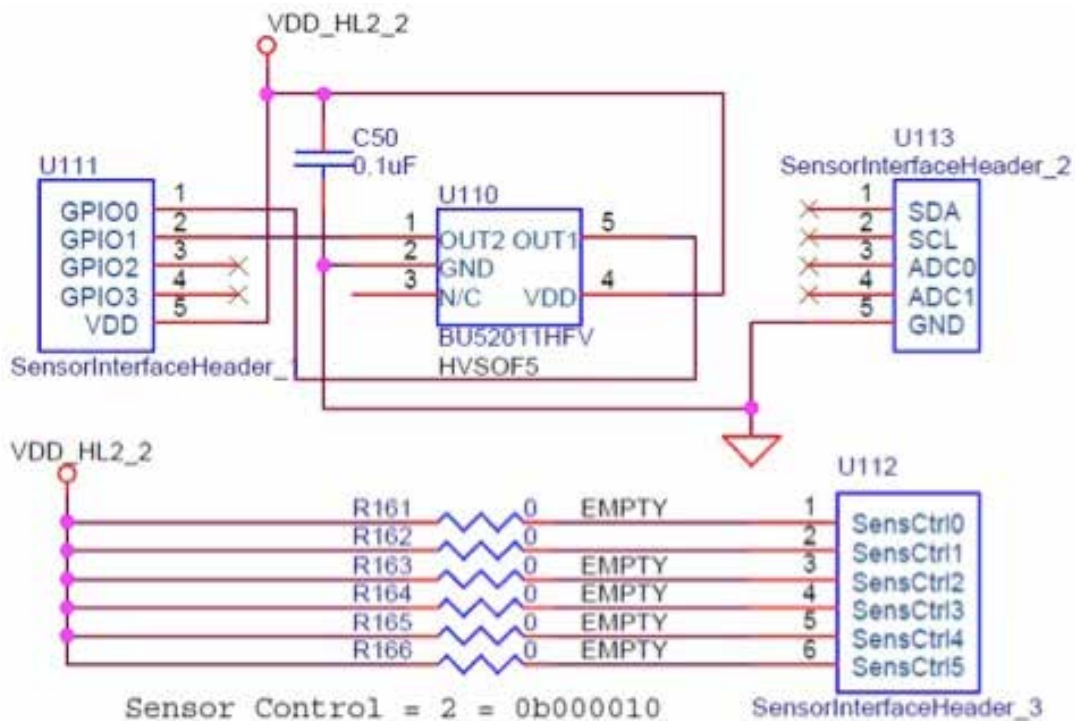

Figure 16: BU52011HFV Breakout Board Schematic

When the BU52011HFV Breakout Board is connected to the running Base Board,

- If no magnetic field is present, all LEDs will be turned off and the output text sent to the PC via UART will read: 'Hall – No Mag Fields Detected'.
- If a magnetic field is present, LED 0 will be turned on and the output text will read 'Hall - Mag Field Detected'.

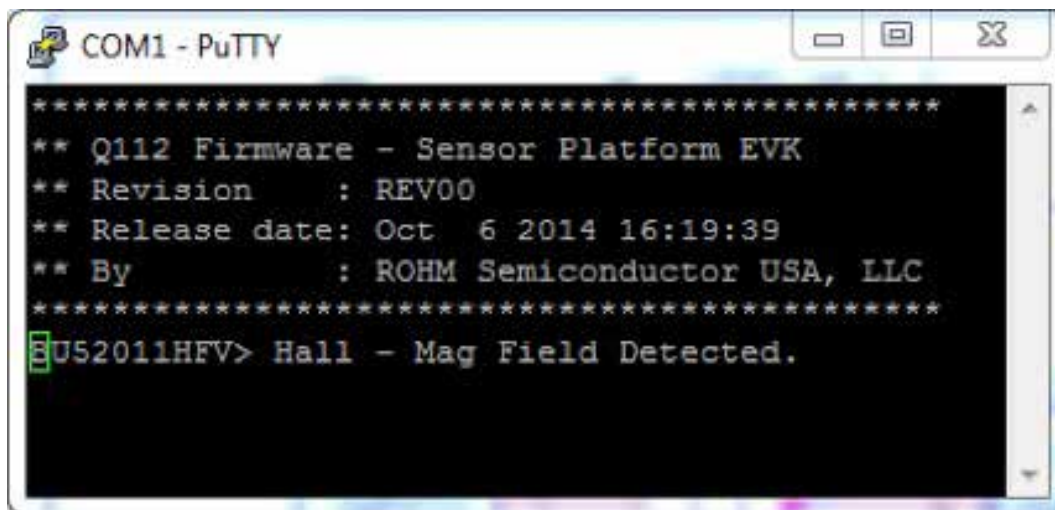

Figure 17: BU52011HFV Breakout Board – Sample Output

## 3.2. Ambient Light Sensor Breakout Boards

### 3.2.1. BH1620FVC Breakout Board

The BH1620FVC Breakout Board provides a simple environment to quickly evaluate the performance of the BH1620FVC sensor. The BH1620FVC is an analog current output ambient light sensor ideal for obtaining ambient light data for adjusting the LCD and keypad backlight in mobile phones to save power and improve visibility.

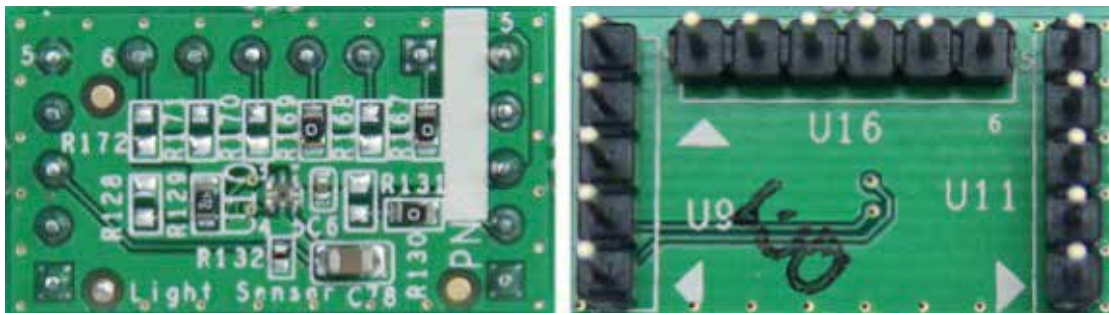

Figure 18: BH1620FVC Breakout Board (Top View and Bottom Views)

The block diagram and schematic of the BU1620FVC Breakout Board are shown in Figures 19 and 20, respectively. Resistors R167 to R172 are used to set the Sensor Control value for the board. The Gain Mode can be set by Pin 3 (ADC0) of Sensor resistors R128 and R131 as listed in Table 3. Pin 5 (IOUT) of the BH1620FVC is connected to the Base Board via Pin 3 (ADC0) of Sensor Interface Header 2. The Base Board detects the Gain Mode configuration by reading the GPIO0 and GPIO1 pins of Sensor Interface Header 1.

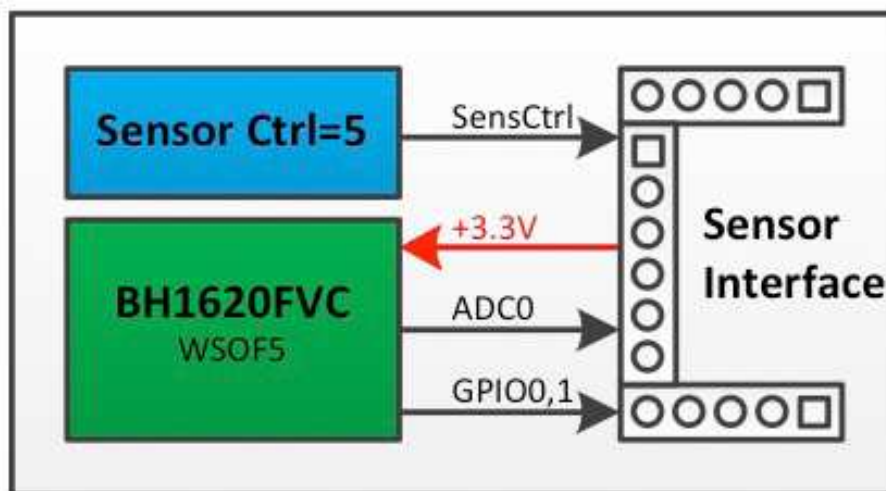

Figure 19: BH1620FVC Breakout Board Block Diagram

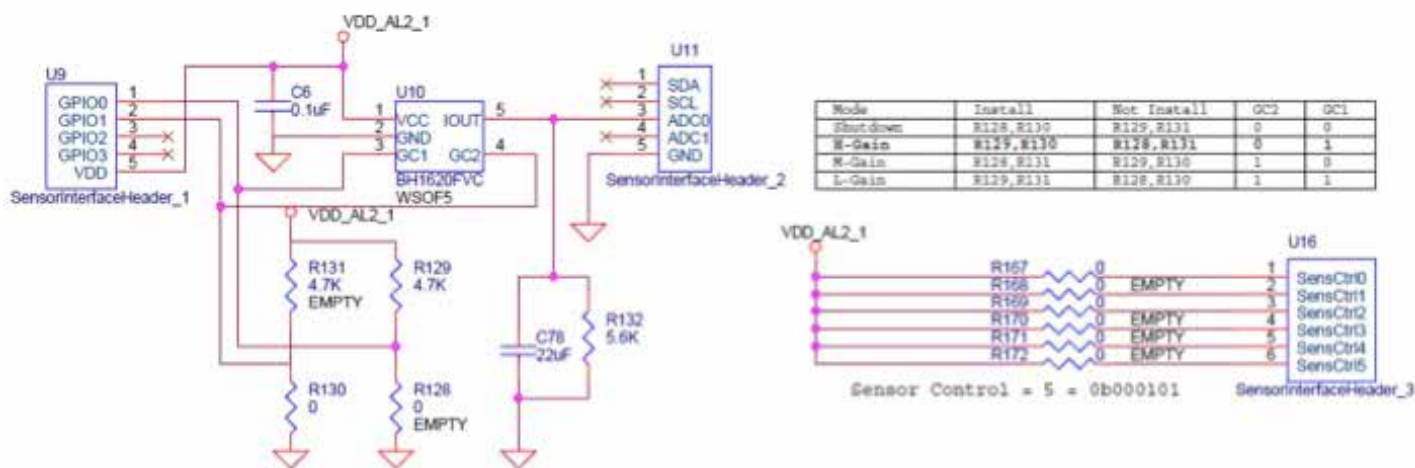

Figure 20: BH1620FVC Breakout Board Schematic

Mode	Install	Do Not Install	GC1	GC2	Illuminance Detection Range
Shutdown	R128, R130	R129, R131	0	0	-
H-Gain (default)	R129, R130	R128, R131	0	1	~1,000
M-Gain	R128, R131	R129, R130	1	0	~10,000
L-Gain	R128, R131	R128, R130	1	1	~100,00

Table 3: BH1620FVC Breakout Board - Gain Mode Configuration

Based on the Gain Mode read from Pins GPIO0 and GPIO1 in Header 1 and the 10bit ADC value converted at the ADC0 pin of Sensor Interface Header 2, the illuminance at the ALS surface (EV) is calculated using the following equations:

- H-Gain Mode

$$E_v = \frac{V}{0.57 \times 10^{-6} \times R_{132}} [1x]$$

Where V is the voltage at the output pin of BH1620FVC and  $R_{132} = 5.6k\Omega$

- M-Gain Mode

$$E_v = \frac{V}{0.057 \times 10^{-6} \times R_{132}} [1x]$$

- L-Gain Mode

$$E_v = \frac{V}{0.0057 \times 10^{-6} \times R_{132}} [1x]$$

The feedback LEDs display the 8bit ADC value scaled from the 10bit ADC at the output pin of BH1620FVC (via 2bit right shift).

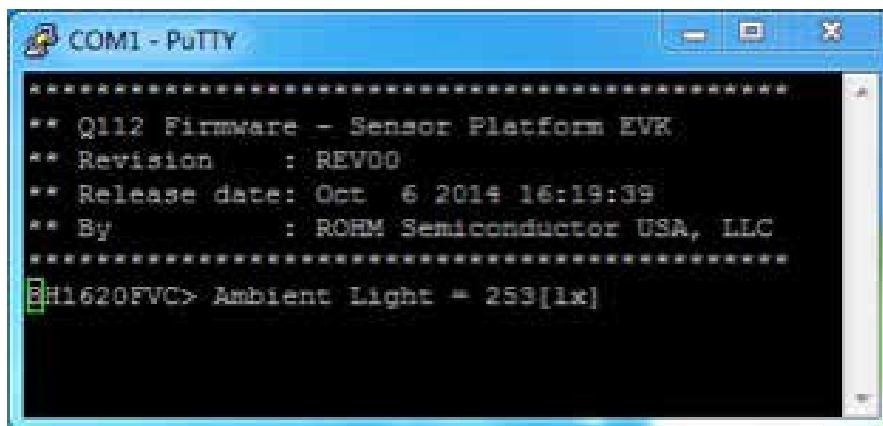

Figure 21: BH1620FVC Breakout Board – Sample Output

### 3.2.2. BH1721FVC Breakout Board

The BH1721FVC Breakout Board provides a simple environment to quickly evaluate the performance of the BH1721FVC sensor. The BH1721FVC is a digital Ambient Light Sensor IC with I<sup>2</sup>C bus I/F optimized for obtaining ambient light data for adjusting LCD and keypad backlighting in mobile phones. It also features a wide detection range (1-65528 lx).

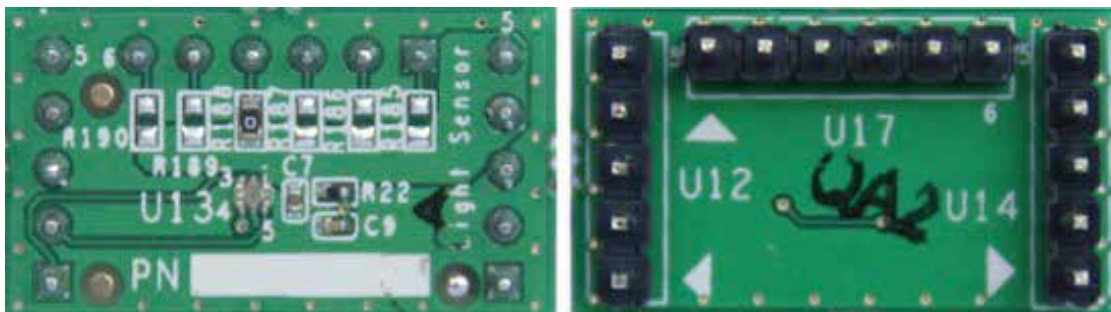

Figure 22: BH1721FVC Breakout Board (Top View and Bottom Views)

The block diagram and schematic of the BH1721FVC Breakout Board are shown in Figures 23 and 24, respectively. Resistors R185 to R190 are used to set the Sensor Control value for the board. The I<sup>2</sup>C interface pins (Pins 3 and 5) are connected to the Base Board via the SDA and SCL pins of Sensor Interface Header 2.

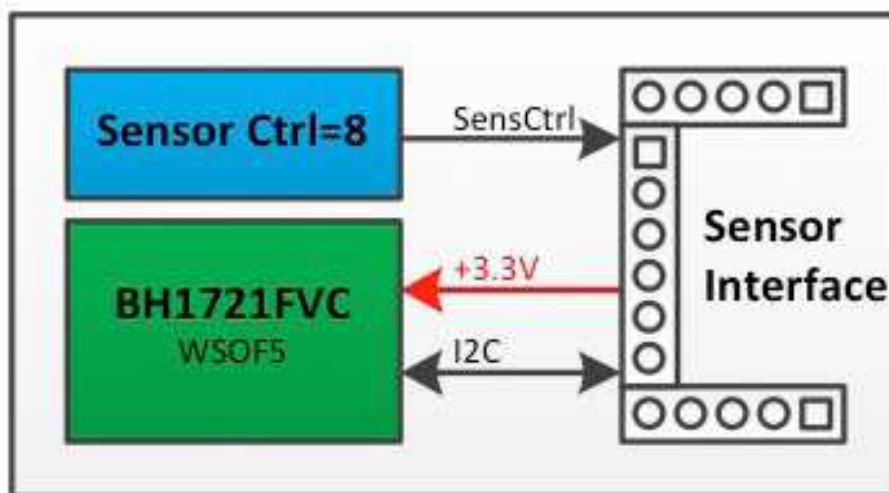

Figure 23: BH1721FVC Breakout Board Block Diagram

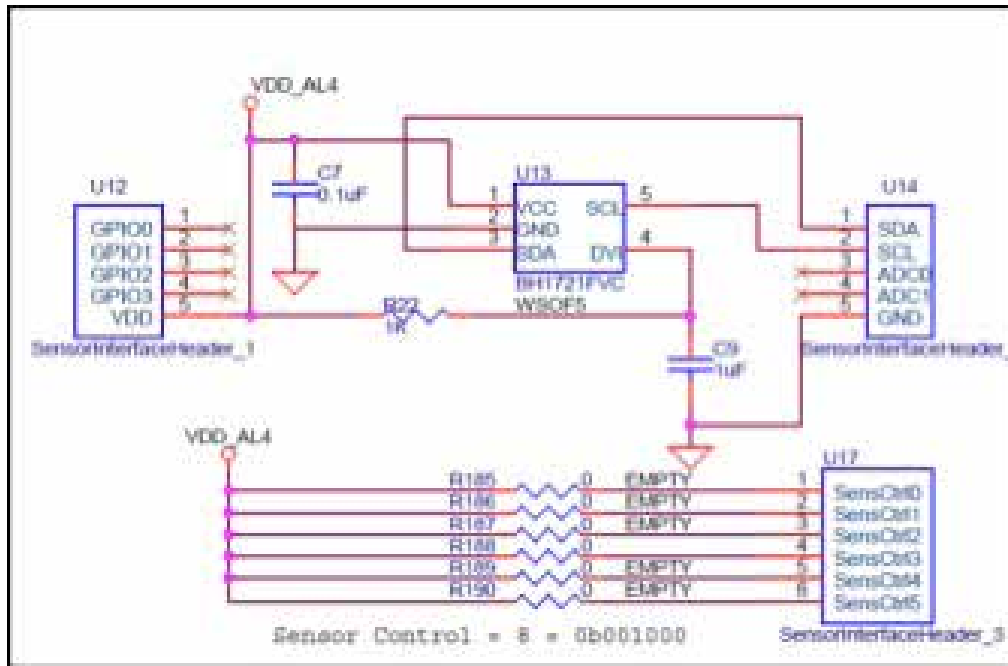

Figure 24: BH1721FVC Breakout Board Schematic

The illuminance of the ALS surface (EV) is calculated as follows:

$$E_v = \frac{\text{Raw Data}}{\text{Accuracy}} [1x]$$

Where Raw Data refers to the 16bit serial output of the ALS. Accuracy denotes measurement accuracy (Typ. 1.2 times)

The feedback LEDs display 16bit serial output of the ALS.

```

COM1 - PuTTY
*****
** Q112 Firmware - Sensor Platform EVK
** Revision      : REV00
** Release date: Oct  6 2014 16:19:39
** By           : ROHM Semiconductor USA, LLC
*****
H1721FVC> Ambient Light = 253[1x]

```

Figure 25: BH1721FVC Breakout Board – Sample Output



### 3.3 UV Sensor Breakout Board

#### 3.3.1. ML8511 Breakout Board

The ML8511 Breakout Board provides a simple environment to quickly evaluate performance of the ML8511 sensor. The ML8511 is a UV sensor capable of detecting the UV intensity both indoors and outdoors. An integrated amplifier converts photocurrent to voltage based on UV intensity, making it easy to connect external circuits such as an ADC. And in power down mode the standby current is typically only 0.1uA, prolonging battery life considerably.

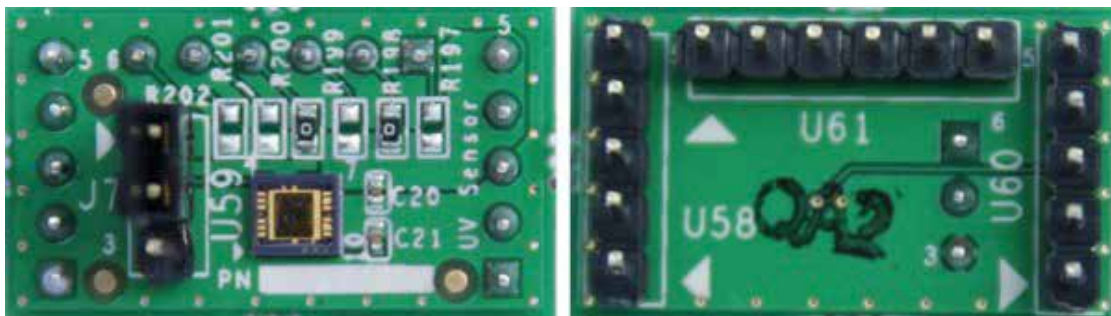

Figure 26: ML8511 Breakout Board (Top View and Bottom View)

The block diagram and schematic of the ML8511 Breakout Board are shown in Figures 27 and 28, respectively. Resistors R197 to R202 are used to set the Sensor Control value for the board. Pin 9 (OUT) of the ML8511 is connected to the Base Board via Pin 3 (ADC0) of Sensor Interface Header 2. Header J7 is used to enable/disable ML8511.

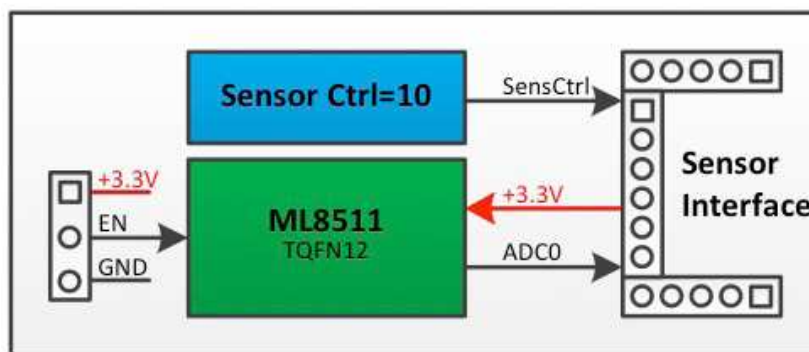

Figure 27: ML8511 Breakout Board Block Diagram

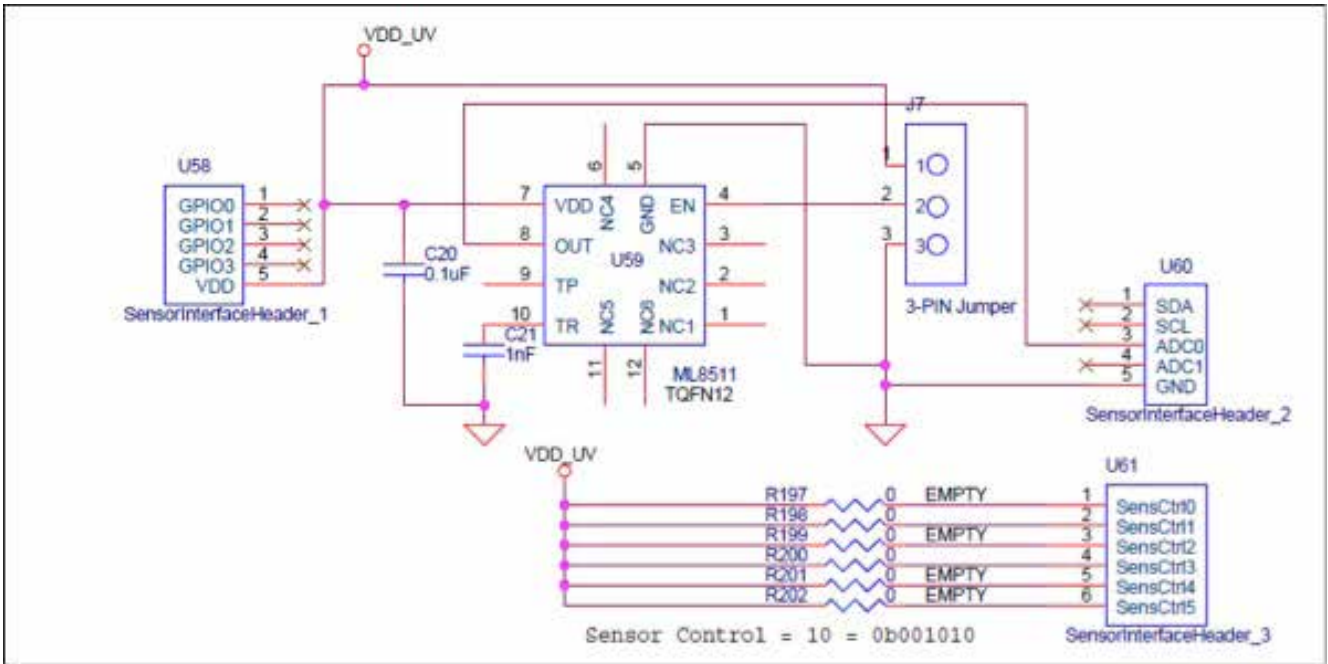

Figure 28: ML8511 Breakout Board Schematic

Designator	Position	Description
J7	2-1	Enable ML8511 (U59)
	2-3	Disable ML8511 (U59)

Table 4: ML8511 Breakout Board – Jumper Positions

The UV intensity of the UV sensor surface (UVI) is calculated as follows:

$$UVI = \frac{V - 2.2}{0.129} + 10 \text{ [mW/cm}^2\text{]}$$

Where V is the voltage at the output pin of ML8511.

The feedback LEDs display the 8bit ADC value scaled down from the 10bit ADC at the output pin of ML8511 (via 2bit right shift).

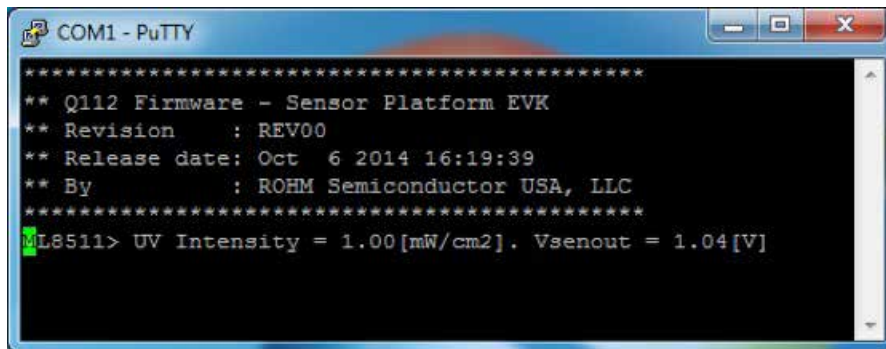

Figure 29: ML8511 Breakout Board – Sample Output

### 3.4. MEMS Sensor Breakout Board

#### 3.4.1. KMX61 Breakout Board

The KMX61 Breakout Board provides a simple environment to quickly evaluate the performance of the KMX61 sensor. The KMX61 is a 6-axis e-compass device with auto-calibration software. It delivers high sensitivity ( $0.05 \mu\text{T}/\text{count}$ ) with stability over temperature ( $\pm 0.05 \%/^{\circ}\text{C}$ ) and is well-suited for a range of smartphone, tablet and health & fitness applications.

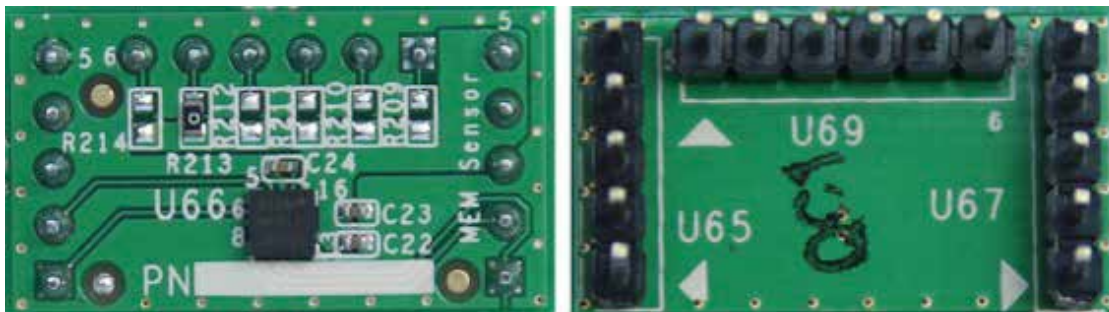

Figure 30: KMX61 Breakout Board (Top View and Bottom Views)

The block diagram and schematic of the KMX61 Breakout Board are shown in Figures 31 and 32, respectively. Resistors R209 to R214 are used to set the Sensor Control value for the board. The I<sup>2</sup>C I/F pins (Pins 4 and 6) and interrupt pins (pins 9 and 11) are connected to the Base Board via the SDA and SCL pins of Sensor Interface Header 2 and GPIO0 and GPIO1 pins of Sensor Interface Header 1, respectively.

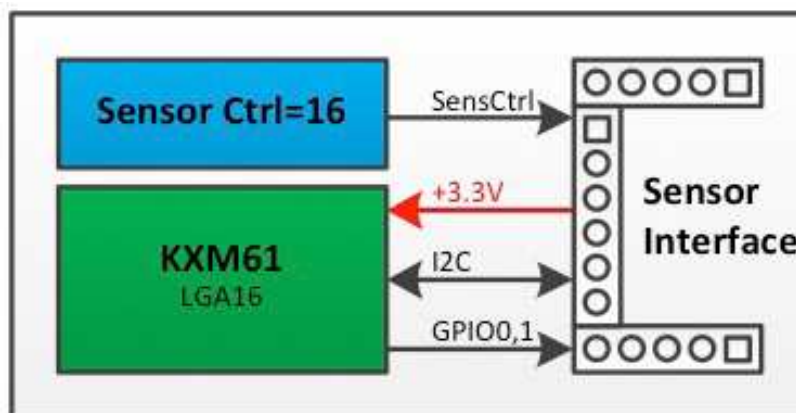

Figure 31: KMX61 Breakout Board Block Diagram

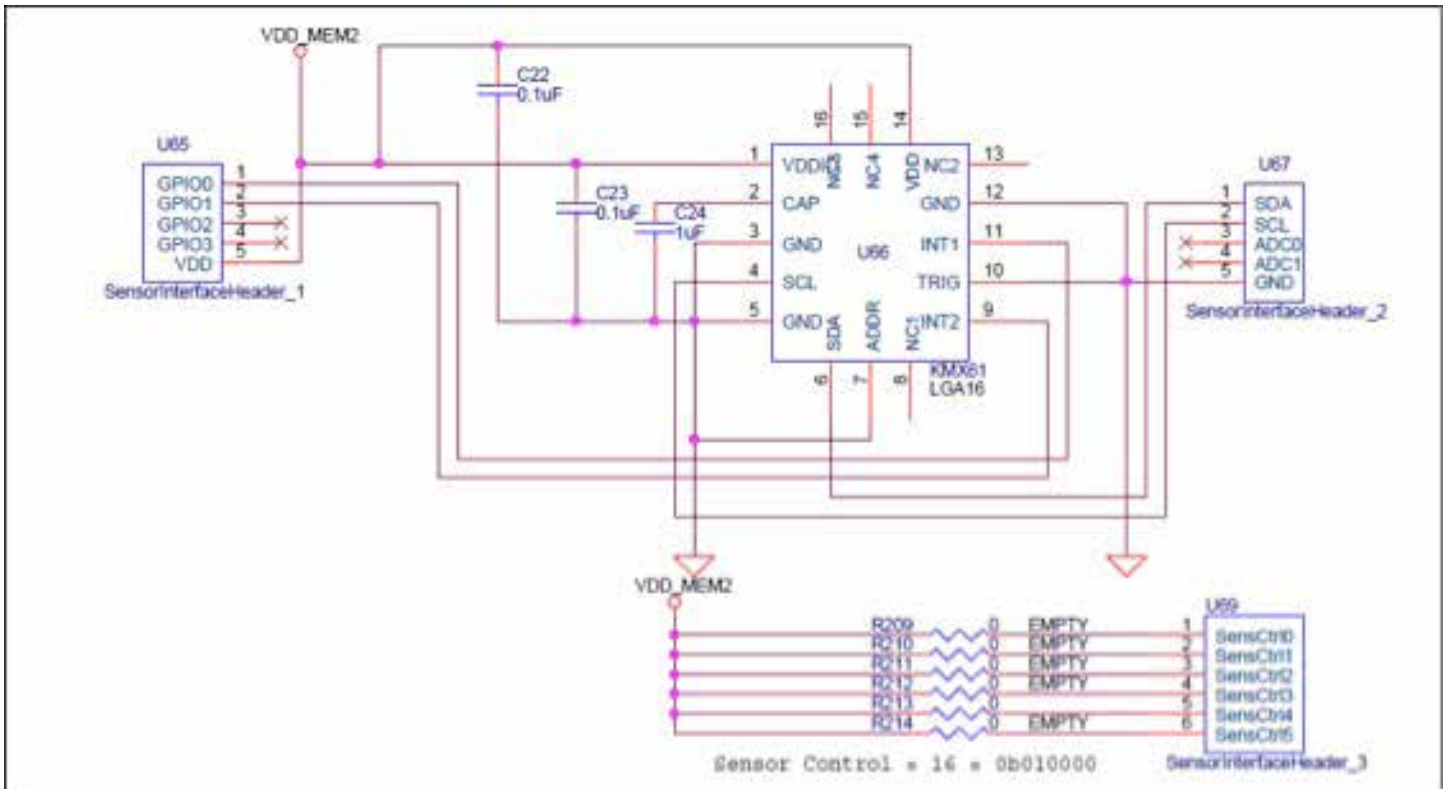

Figure 32: KMX61 Breakout Board Schematic

Acceleration values (X, Y and Z) of the KMX61 are calculated using the following equations:

$$ACCEL_x = \frac{ACCEL\_XOUT}{Sensitivity} [g]$$

$$ACCEL_y = \frac{ACCEL\_YOUT}{Sensitivity} [g]$$

$$ACCEL_z = \frac{ACCEL\_ZOUT}{Sensitivity} [g]$$

Where: ACCEL\_XOUT are the X-axis accelerometer outputs ACCEL\_XOUT\_L (0Ah) and ACCEL\_XOUT\_H (0Bh).  
 ACCEL\_YOUT are the Y-axis accelerometer outputs ACCEL\_YOUT\_L (0Ch) and ACCEL\_YOUT\_H (0Dh).  
 ACCEL\_ZOUT are the Z-axis accelerometer outputs ACCEL\_ZOUT\_L (0Eh) and ACCEL\_ZOUT\_H (0Fh).

Resolution [bits]	Range	Sensitivity (Typ.) [counts/g]
14	± 8g	1024
12	± 2g	1024
	± 4g	512
	± 8g	256

Table 5: KMX61 Breakout Board – Acceleration Sensitivity

In the default software setting, the KMX61 is configured to operate at 14bit resolution and ± 2g.

The magnetic values (X, Y and Z) of the KMX61 are calculated using the following equations:

$$\text{MAG}_x = \text{MAG\_XOUT} \times \text{Sensitivity} [\mu\text{T}]$$

$$\text{MAG}_y = \text{MAG\_YOUT} \times \text{Sensitivity} [\mu\text{T}]$$

$$\text{MAG}_z = \text{MAG\_ZOUT} \times \text{Sensitivity} [\mu\text{T}]$$

Where: MAG\_XOUT are the X-axis magnetometer outputs MAG\_XOUT\_L (12h) and MAG\_XOUT\_H (13h).

MAG\_YOUT are the Y-axis magnetometer outputs MAG\_YOUT\_L (14h) and MAG\_YOUT\_H (15h).

MAG\_ZOUT are the Z-axis magnetometer outputs MAG\_ZOUT\_L (16h) and MAG\_ZOUT\_H (16h).

Sensitivity refers to the Magnetic Sensitivity (Typ. 0.146  $\mu\text{T}/\text{count}$ )

The feedback LEDs indicate the tilt position of the KX022 surface:

- If the tilt position is Face-Up, LED 3 will be turned on.
- If the tilt position is Face-Down, LED 4 will be turned on.
- If the tilt position is Left, LED 7 will be turned on.
- If the tilt position is Right, LED 0 will be turned on.
- If the tilt position is Up, LED 5 will be turned on.
- If the tilt position is Down, LED 2 will be turned on.

```

COM1 - PuTTY
*****
** Q113 Firmware - Sensor Platform EVK
** Revision      : REV00
** Release date: Oct  8 2014 16:18:39
** By           : ROHM Semiconductor USA, LLC
*****
KMX61> AccelX_raw = -42, AccelX_scaled = -0.04102[g], AccelY_raw = 17, AccelY_scaled = 0.01660[g], AccelZ_raw = 1005, AccelZ_scaled = 0.56145[g]
KMX61> MagX_raw = 229, MagX_scaled = 33.28000[uT], MagY_raw = 480, MagY_scaled = 70.08000[uT], MagZ_raw = 487, MagZ_scaled = 70.37200[uT]

```

Figure 33: KMX61 Breakout Board – Sample Output

### 3.5. Temperature Sensor Breakout Board

#### 3.5.1. BDE0600G Breakout Board

The BDE0600G Breakout Board provides a simple environment to quickly evaluate the performance of the BDE0600G sensor. The BDE0600G is a low quiescent current (16 $\mu$ A), high accuracy thermostat (temperature switch) IC that integrates a temperature sensor, reference voltage regulator, D/A converter, and comparator. The OS terminal state is changed logically when detecting temperature independently. Open Drain Output (Active L) is enabled as well.

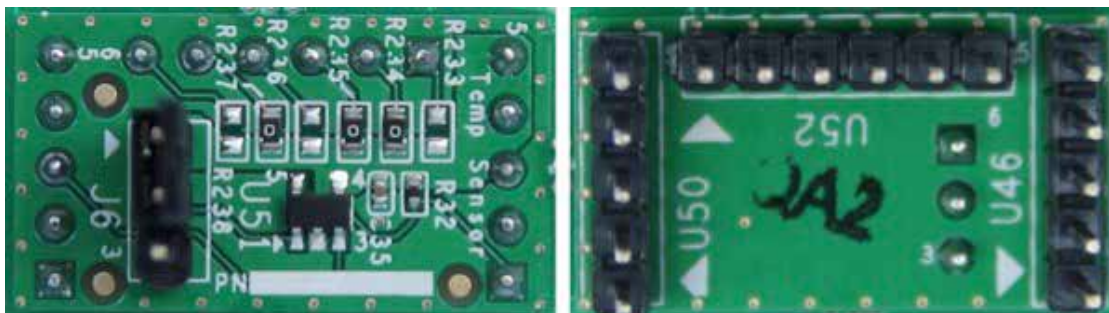

Figure 34: BDE0600G Breakout Board (Top View and Bottom Views)

The block diagram and schematic of the BDE0600G Breakout Board are shown in Figures 35 and 36, respectively. Resistors R233 to R238 are used to set the Sensor Control value for the board. The output pin VTEMP (Pin 3) and digital thermostat output pin OS (Pin 5) of the BDE0600G are connected to the Base Board via the ADC0 pin of Sensor Interface Header 2 and GPIO0 pin of Sensor Interface Header 1, respectively. Header J6 is used to set the detection temperature.

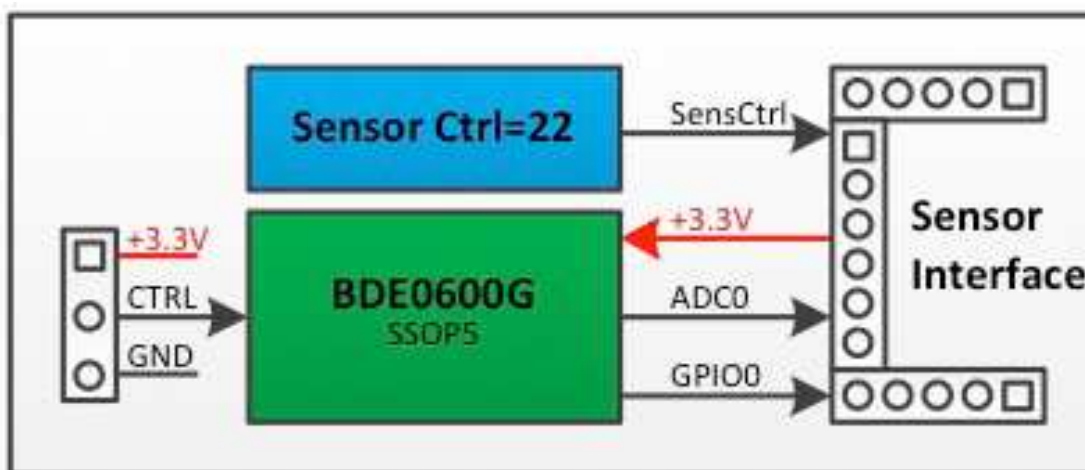

Figure 35: BDE0600G Breakout Board Block Diagram

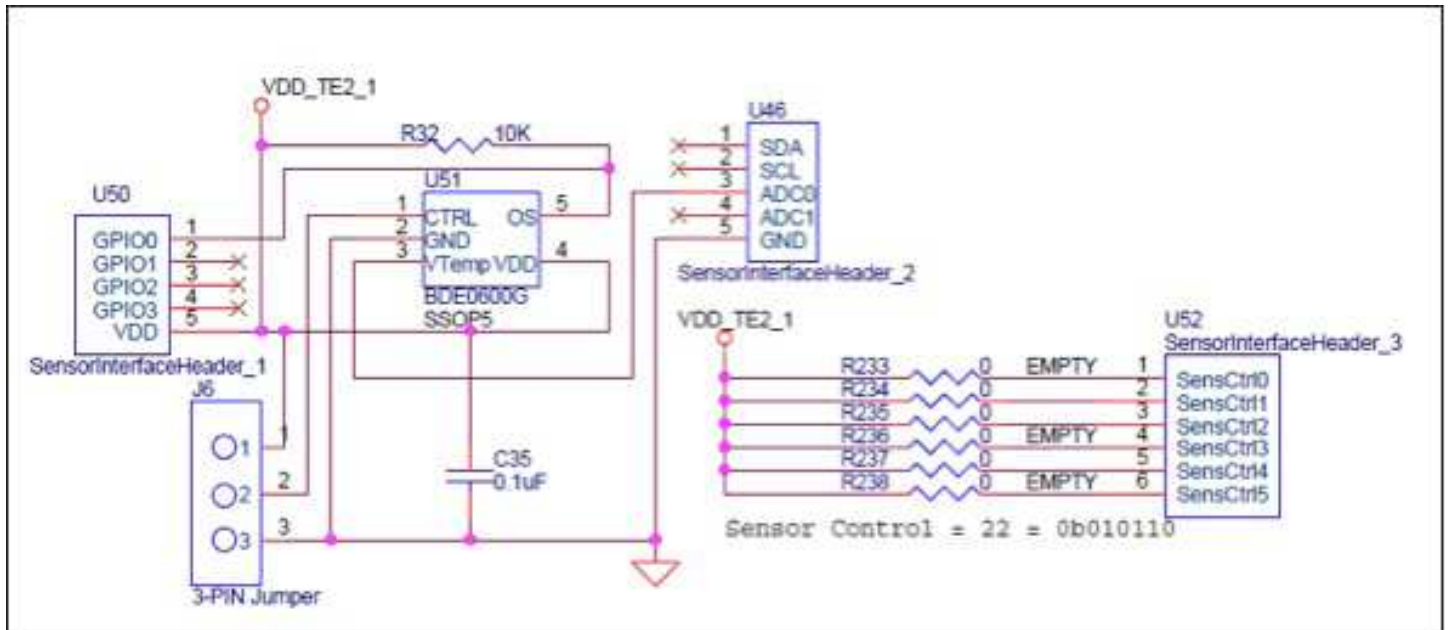

Figure 36: BDE0600G Breakout Board Schematic

Designator	Position	Detection Temperature (°C)
J6	Open	65
	2 - 1	60
	2 - 3	55

Table 6: BDE0600G Breakout Board – Jumper Positions

The temperature of the BDE0600G sensor is calculated as follows:

$$\text{Temp} = \frac{V - V_0}{\text{Sensitivity}} + \text{Temp}_0 [\text{°C}]$$

Where V is the voltage at the output pin of BDE0600G and V<sub>0</sub> is the output voltage at Temp<sub>0</sub>. (1.753 V@30°C). Sensitivity refers to the temperature sensitivity (Typ. -10.68 mV/°C).

The feedback LEDs display the 8bit ADC value scaled down from the 10bit ADC at the output pin of BDE0600G (via 2bit right shift).

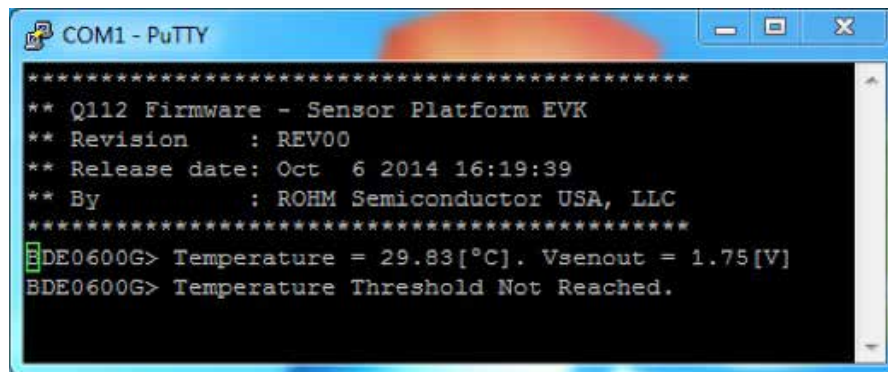

Figure 37: BDE0600G Breakout Board – Sample Output

## Appendix A: Programming the Base Board Instructions

This appendix explains how to program the default software into the Base Board using the DTU8 Debugger.

- Step 1: If the U8 Code Development tools are not installed on your PC, please install them from the CD included with the nanoEASE. (The U8Dev Suite includes 18 manuals to help you become familiarized with LAPIS Semiconductor's micros, development tools, nanoEASE debugger, and more). Follow the instructions in ReleaseNote\_e.pdf when installing the tools.
- The tools provided with this kit may not be the most up-to-date. Go to <https://www.lapis-semi.com/customer/lpmcu/login.html> to register and download the latest version of the tools.
- Step 2: Download the source code from <https://github.com/ROHMUSDC/ROHMSensorPlatformEVK/>. The default software is stored in directory "Q112 Firmware - Sensor Platform EVK\\_output\\_hex\Q112-SENSORPLATFORMEVK.HEX".
- Step 3: Connect the nanoEASE to the board as indicated in the figure below. Change the Reset Selection Header (J2) to the nE\_RST position (connect Pin 2 and 3).



Figure 38: nanoEASE - Base Board Connection Diagram



Figure 39: nanoEASE - Base Board Connection

- Step 4: Start the DTU8 Debugger by selecting Start → All Programs → U8 Tools → nX-U8 → DTU8 Debugger.
- Step 5: In the Target Settings window, select ML610112 in the *Target chip* field and nanoEASE in the *Target ICE* field.



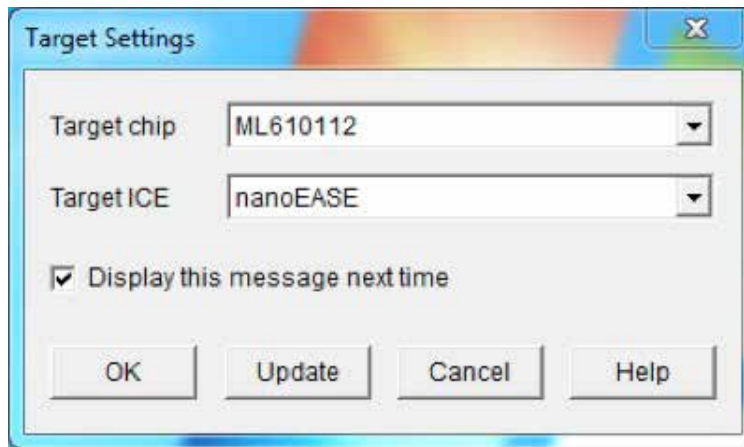

Figure 40: DTU8 Debugger Settings

- Step 6: Load the default software into the Base Board by clicking on the Load Program File button and selecting the default software file.

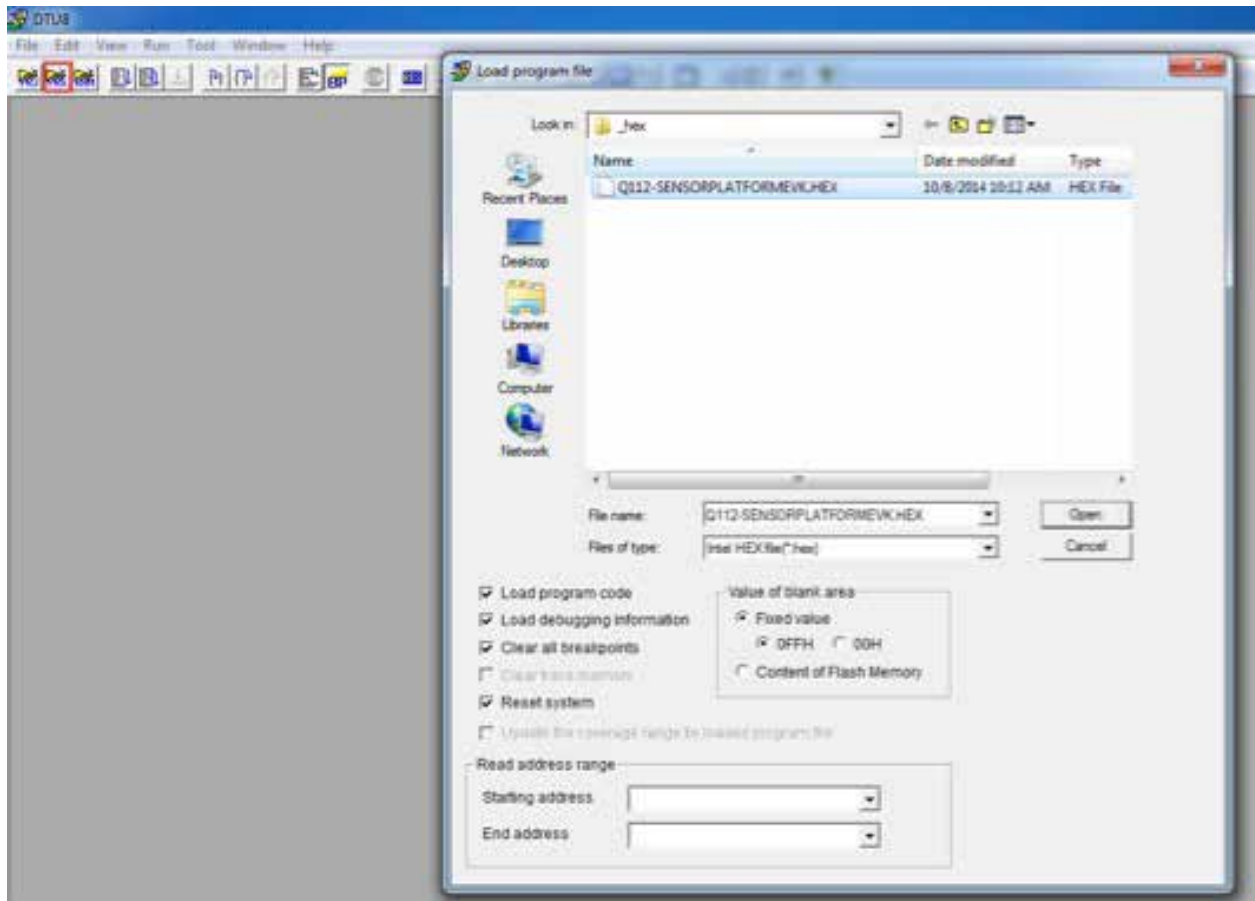

Figure 41: DTU8 Debugger - Loading Software Files Into the Base Board

## Notes

No copying or reproduction of this document, in part or in whole, is permitted without the consent of ROHM Co.,Ltd.

The content specified herein is subject to change for improvement without notice.

The content specified herein is for the purpose of introducing ROHM's products (hereinafter "Products"). If you wish to use any such Product, please be sure to refer to the specifications, which can be obtained from ROHM upon request.

Examples of application circuits, circuit constants and any other information contained herein illustrate the standard usage and operations of the Products. The peripheral conditions must be taken into account when designing circuits for mass production.

Great care was taken in ensuring the accuracy of the information specified in this document. However, should you incur any damage arising from any inaccuracy or misprint of such information, ROHM shall bear no responsibility for such damage.

The technical information specified herein is intended only to show the typical functions of and examples of application circuits for the Products. ROHM does not grant you, explicitly or implicitly, any license to use or exercise intellectual property or other rights held by ROHM and other parties. ROHM shall bear no responsibility whatsoever for any dispute arising from the use of such technical information.

The Products specified in this document are intended to be used with general-use electronic equipment or devices (such as audio visual equipment, office-automation equipment, communication devices, electronic appliances and amusement devices).

The Products specified in this document are not designed to be radiation tolerant.

While ROHM always makes efforts to enhance the quality and reliability of its Products, a Product may fail or malfunction for a variety of reasons.

Please be sure to implement in your equipment using the Products safety measures to guard against the possibility of physical injury, fire or any other damage caused in the event of the failure of any Product, such as derating, redundancy, fire control and fail-safe designs. ROHM shall bear no responsibility whatsoever for your use of any Product outside of the prescribed scope or not in accordance with the instruction manual.

The Products are not designed or manufactured to be used with any equipment, device or system which requires an extremely high level of reliability the failure or malfunction of which may result in a direct threat to human life or create a risk of human injury (such as a medical instrument, transportation equipment, aerospace machinery, nuclear-reactor controller, fuel-controller or other safety device). ROHM shall bear no responsibility in any way for use of any of the Products for the above special purposes. If a Product is intended to be used for any such special purpose, please contact a ROHM sales representative before purchasing.

If you intend to export or ship overseas any Product or technology specified herein that may be controlled under the Foreign Exchange and the Foreign Trade Law, you will be required to obtain a license or permit under the Law.



## ROHM Customer Support System

Thank you for accessing ROHM's product information. For more product information and catalogs please contact us at <http://www.rohm.com/contact/>