



Chipsmall Limited consists of a professional team with an average of over 10 year of expertise in the distribution of electronic components. Based in Hongkong, we have already established firm and mutual-benefit business relationships with customers from,Europe,America and south Asia,supplying obsolete and hard-to-find components to meet their specific needs.

With the principle of “Quality Parts,Customers Priority,Honest Operation,and Considerate Service”,our business mainly focus on the distribution of electronic components. Line cards we deal with include Microchip,ALPS,ROHM,Xilinx,Pulse,ON,Everlight and Freescale. Main products comprise IC,Modules,Potentiometer,IC Socket,Relay,Connector.Our parts cover such applications as commercial,industrial, and automotives areas.

We are looking forward to setting up business relationship with you and hope to provide you with the best service and solution. Let us make a better world for our industry!



## Contact us

Tel: +86-755-8981 8866 Fax: +86-755-8427 6832

Email & Skype: info@chipsmall.com Web: www.chipsmall.com

Address: A1208, Overseas Decoration Building, #122 Zhenhua RD., Futian, Shenzhen, China



TABLE 1		
AHSP P/N	LENGTH "A"	CUSTOMER P/N
NDAQGJ-C102	5000 ±125	SF-NDAQGJ100G-005M

REVISIONS						
ZONE	REV.	SCR NUMBER	DESCRIPTION	BY	DATE	APPROVED
	1		PRELIMINARY DESIGN		10/12/2015	DC

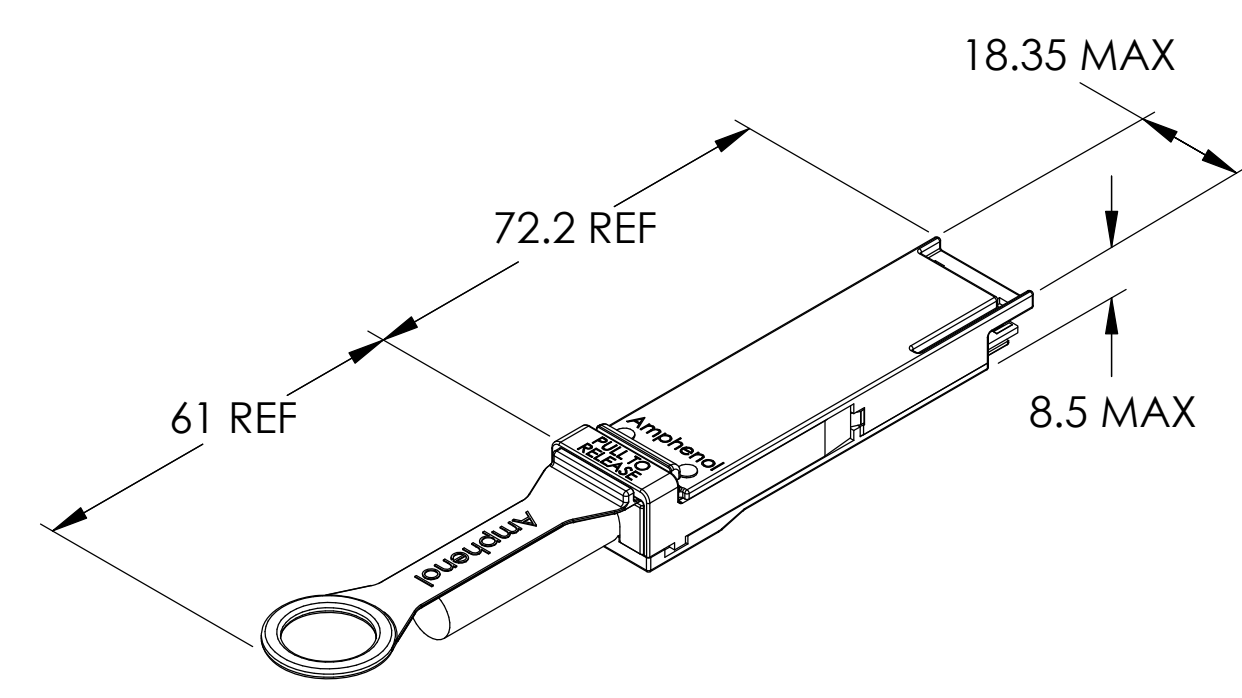
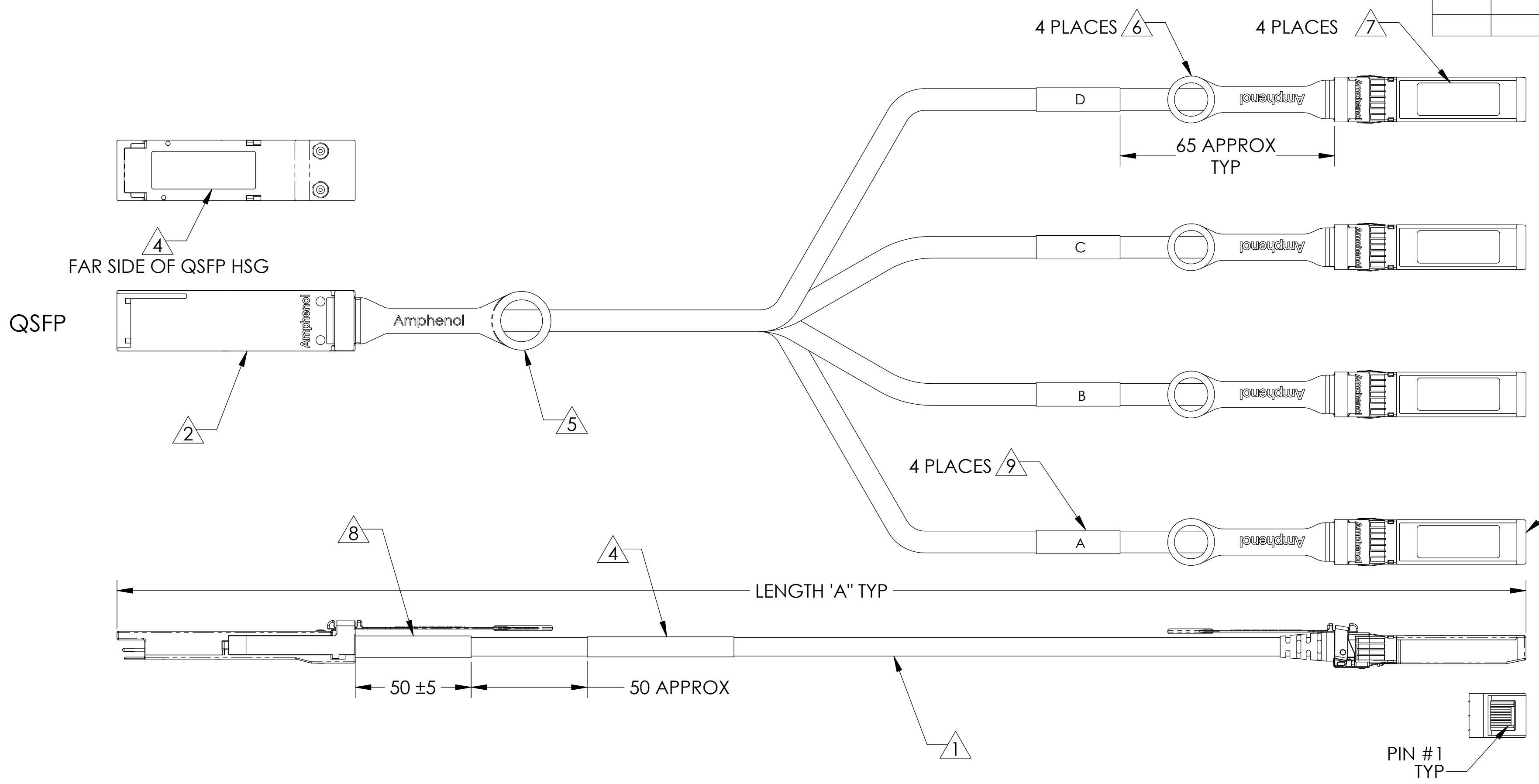

QSFP DIECAST DIMENSIONS

TABLE 2	
ITEM No.	DESCRIPTION
1	26 AWG, 2-PR, PVC BLACK, UL CL2, CSA FT4, 75°C
2	PLUG, QSFP+, REFERENCE SFF-8661
3	PLUG, SFP+, REFERENCE SFF-8432, PULL TO RELEASE
4	LABEL, QSFP CONN - AHSP P/N, REV, DATE CODE, LENGTH, CoO & SERIAL NUMBER
5	QSFP LANYARD - GREEN (PANTONE 347C)
6	SFP+ LANYARD - GREEN (PANTONE 347C)
7	LABEL, SFP CONN - AHSP P/N, REV, DATE CODE, LENGTH, CoO & SERIAL NUMBER
8	SHRINK TUBING
9	LABEL, REFERENCE DESIGNATOR

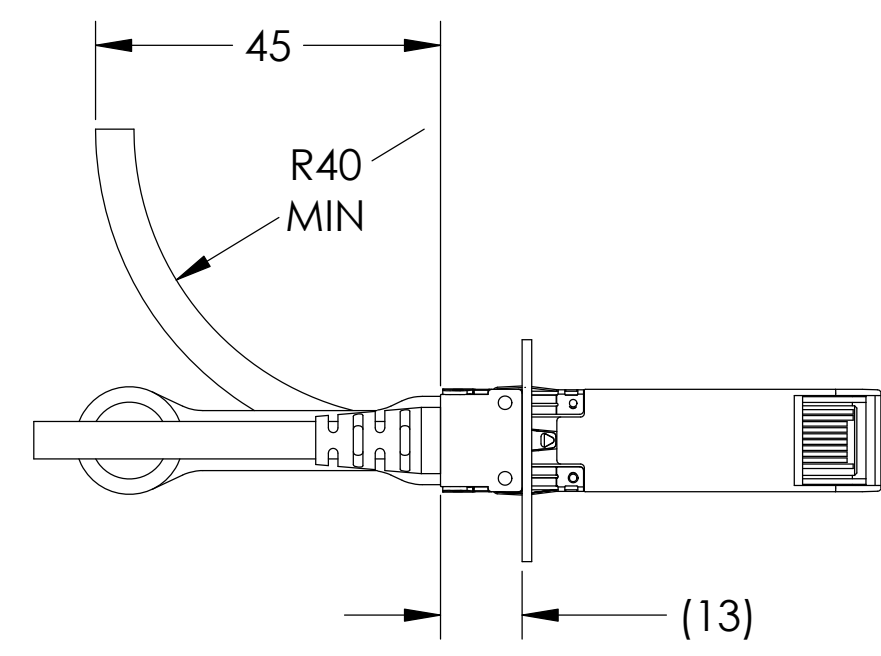

SFP+ BEND DISTANCE FROM FACEPLATE

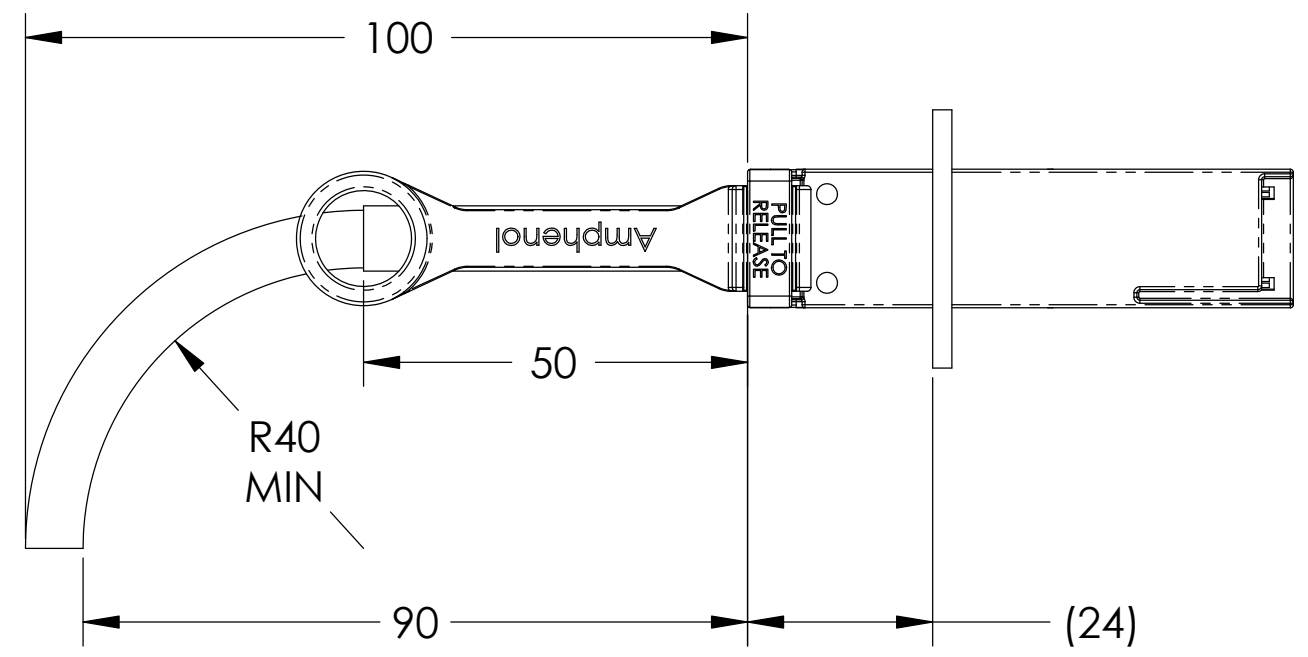

QSFP BEND DISTANCE FROM FACEPLATE

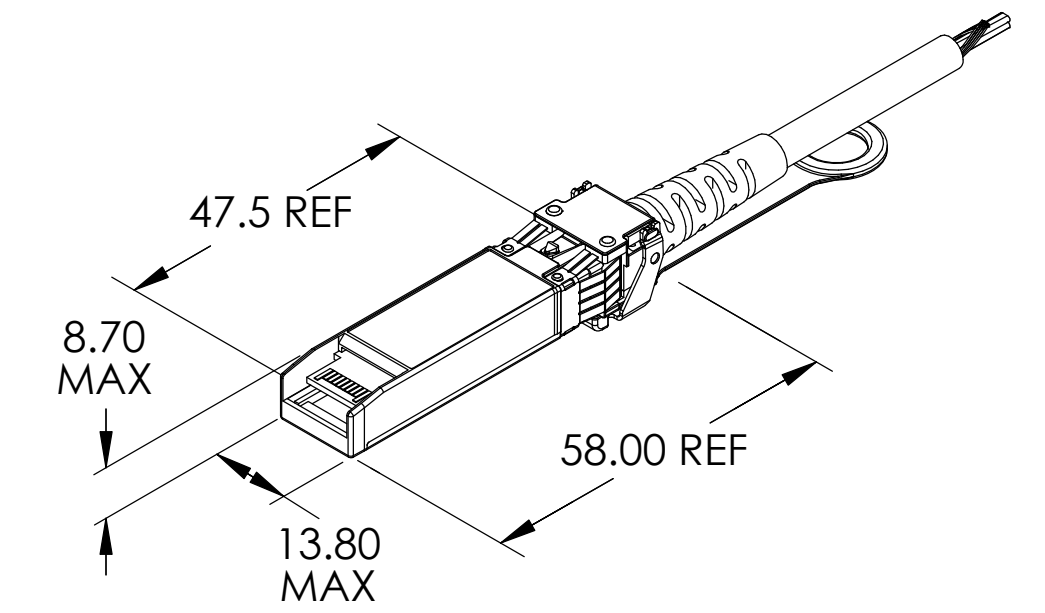

SFP+ DIECAST DIMENSIONS

- 9. CABLE ASSEMBLIES SHALL BE TESTED PER AMPHENOL SPECIFICATIONS AND PROCEDURES.
- 8. CABLE ASSEMBLIES, COMPONENTS, SUB-COMPONENTS, MATERIALS AND MFG PROCESSES MUST MEET AMPHENOL SPECIFICATIONS.
- 7. UL LABEL MUST BE ON THE SHIPPING CARTON PER SUBJECT 764 OF THE UL COMPONENT WIRING HARNESS (ZPFW2) FILE #E86140. CSA LABEL MUST BE ON SHIPPING CARTON.
- 6. PACKAGE COMPLETED ASSY IN AN APPROPRIATELY SIZED ESD BAG.
- 5. EPROM CONTENT SHALL BE COMPLIANT WITH SFF-8636 AND SFF-8472 SPECIFICATIONS FOR 100GBASE-CR4. EPROM REVISION IS EQUAL TO AHSP PART NUMBER REVISION.
- 4. CABLE ASSEMBLIES MUST MEET SHIELDING EFFECTIVENESS REQUIREMENTS OF 35dB FROM 1-10GHz AND 30dB FROM 10-18GHz.
- 3. COMPLIANT TO EU DIRECTIVE 2011/65/EU - RoHS2.
- 2. ASSEMBLIES SHALL BE COMPLIANT TO 100GBASE-CR4 SPECIFICATION.
- 1. THIS DRAWING IS RESERVED FOR AMPHENOL CABLES ON DEMAND.

NOTES: UNLESS OTHERWISE SPECIFIED

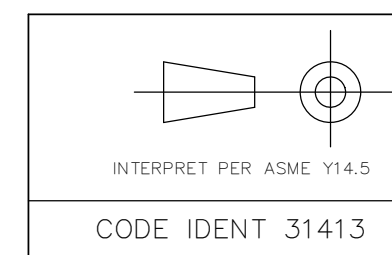

CODE IDENT 31413

TOLERANCES	DWN	CHK	APVD	EM
0.0	± 0.25	10/12/2015	DC	
0.00	± 0.08	10/12/2015	DD	
ANGLES	± 1.0°	10/12/2015	EM	

<b>Amphenol AHSP</b>	
A Division of Amphenol Corporation 200 Innovative Way, Suite 201, Nashua, N.H. 03062 (603) 879-3000	
TITLE	CABLE ASSEMBLY, QSFP/(4)SFP+, PSV, 100U, 100GbE, 26AWG
PART NO.	SEE TABLE 3
DRAWING NO.	P-NDAQGJ-C199
SIZE	D
SCALE	1:1
SHEET	1 OF 3

REVISIONS						
ZONE	REV.	SCR NUMBER	DESCRIPTION	BY	DATE	APPROVED
			SEE SHEET 1			

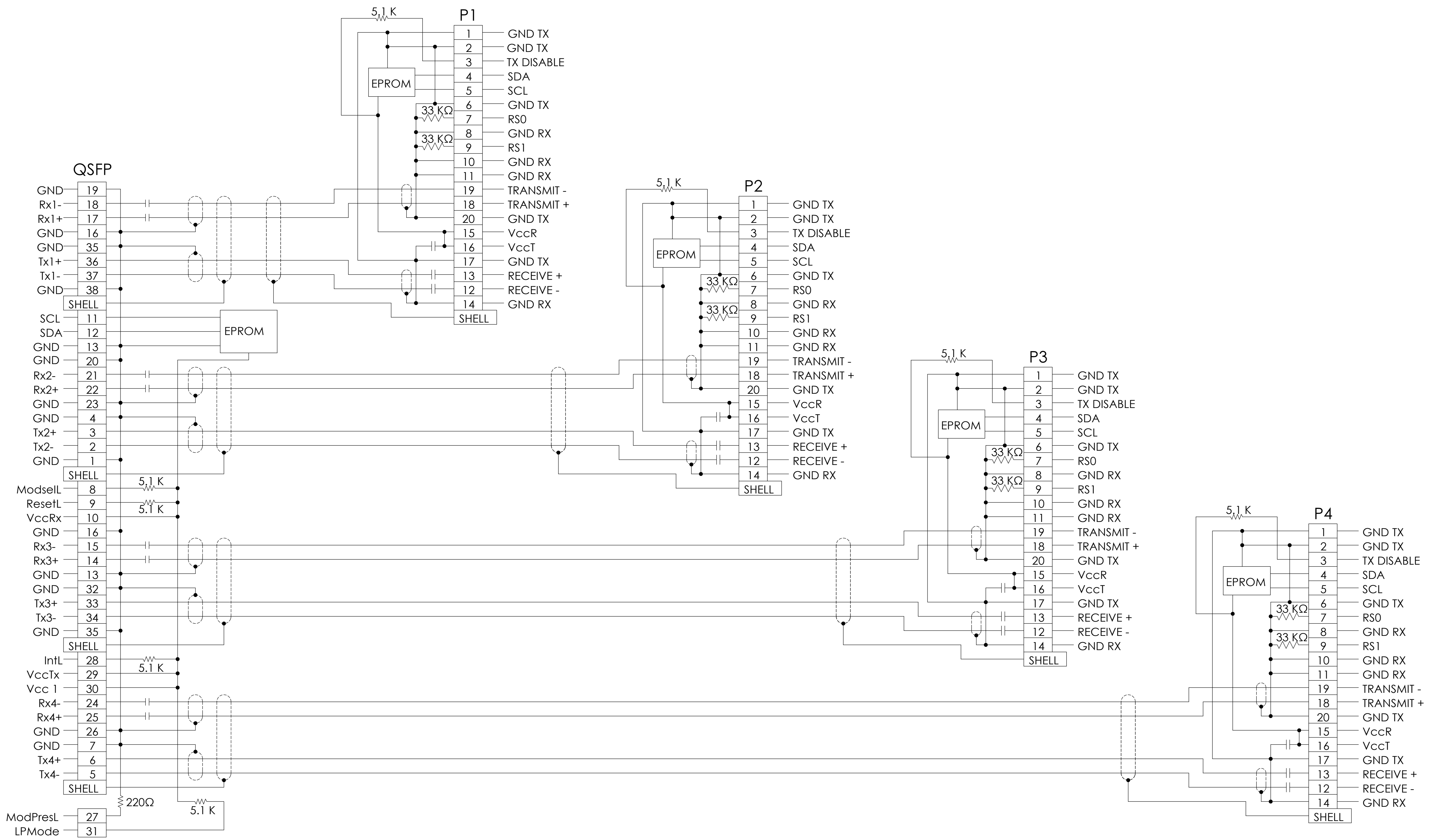

NOTE: DC BLOCKING CAP VALUE IS 0.1μF

TOLERANCES	DWN	CHK	APVD	DATE	TITLE
0.0	± 0.25	DC		10/12/2015	<b>Amphenol AHSP</b> A Division of Amphenol Corporation 200 Innovative Way, Suite 201, Nashua, N.H. 03062 (603) 879-3000 <b>CABLE ASSEMBLY, QSFP/(4)SFP+, PSV, 100Ω, 100GbE, 26AWG</b>
0.00	± 0.08	DD		10/12/2015	
			EM	10/12/2015	
ANGLES	± 1.0°				

UNLESS OTHERWISE SPECIFIED DIMENSIONS ARE IN MM

THESE DRAWINGS AND SPECIFICATIONS ARE THE PROPERTY OF AMPHENOL CORPORATION AND SHALL NOT BE REPRODUCED OR COPIED OR USED AS THE BASIS FOR THE MANUFACTURE OR SALE OF APPARATUS WITHOUT THE WRITTEN PERMISSION OF AMPHENOL CORPORATION	PART NO. SEE TABLE 3	REV 1
INTERPRET PER ASME Y14.5	DRAWING NO. P-NDAQGJ-C199	REV 1
CODE IDENT 31413	SIZE D	SCALE 1:1
		SHEET 2 OF 3

TABLE 3				
AHSP P/N	AHSP REV	CUT LENGTH "A"	MANUAL SOLDER	AUTO SOLDER
NDAQGJ-C102	A	26.77 FT	YES	YES

TABLE 5 - AMPHENOL SPECIFICATIONS	
ACS-1152	AMPHENOL REGULATED MATERIALS
ACS-1154	EPROM PROGRAMMING
ACS-1186	LEAD-FREE SOLDER
ACS-1199	HIGH SPEED ASSEMBLY TEST
TMS 115-0001	CABLE ASSEMBLY MFG PROCESS

REVISIONS						
ZONE	REV.	SCR NUMBER	DESCRIPTION	BY	DATE	APPROVED
			SEE SHEET 1			

TABLE 4 - PART LIST FOR 26AWG ASSEMBLIES					
ITEM	AHSP P/N	AHSP P/N	DESCRIPTION	QTY	U of M
1	023-0010-034	1602699963	CBL RND 2PR 26G EXD	SEE CUT LENGTH "A" IN TABLE 3	FT
2	023-Q030-040	NA	CVR DIECAST QSFP	1	EA
3	023-Q020-126	NA	HSG DIECAST QSFP AMPHENOL LOGO	1	EA
4	023-Q120-001	602480001	LATCH RELEASE DIECAST QSFP COPPER	1	EA
5	023-0000-054	605480001	SPRING COMPRESSION	2	EA
6	023-0000-052	555880001	RIVET LOW PRO MINI-SAS	2	EA
7	023-Q075-007	NA	ASM PCB QSFP PASSIVE 30AWG EXD	1	EA
8	023-0000-015	532320001	ADH HOT MELT AMBER 430F 3M 3779-PG	0.01617	LB
9	527-4943-000	NA	AHSP STANDARD QSFP LABEL	1	EA
10	527-4945-000	NA	AHSP CABLE LABEL SPLITTER LEG INDICATOR	4	EA
11	023-Q130-002	613890001	DUST COVER QSFP BLUE	1	EA
12	023-Q080-025	587240025	LANYARD QSFP PULL TO RELEASE PANTONE 347C (GRN) AMPH 2.4	1	EA
13	023-P075-028	NA	PCBA SFP28 30AWG HAL-FREE	4	EA
14	023-P020-013	612440012	HSG DIECAST SFP .235 CBL	4	EA
15	023-P030-005	612420005	CVR DIECAST SPRING GND COPPER SFP AMPHENOL	4	EA
16	023-0000-042	606480001	CVR LATCH RLS SFP GEN2 SS301	4	EA
17	023-0000-043	606570001	LATCH RLS DIECAST SLIDE SFP GEN2	4	EA
18	023-0000-039	605560001	SPRING COMPRESSION SFP LEE C1006AA04M	4	EA
19	023-0000-035	580000001	RIVET SEMI-TUBULAR OVAL HEAD STEEL	8	EA
20	023-0000-036	601140001	GROUND FINGERS SFP 268 BRASS	4	EA
21	023-P000-001	613250001	BALE RELEASE (U-CLIP) SFP+ SS304	4	EA
22	023-0000-017	24832	TAPE COPPER 1/4 CONDUCTIVE CCH-36-101-0025	0.40	FT
23	023-0080-025	NA	LANYARD SFP PULL TO RELEASE GRN AMPH 2.0"	4	EA
24	023-0130-001	613880001	DUST COVER SFP BLUE	4	EA
25	527-4944-000	NA	AHSP STANDARD PLUG LABEL SFP	4	EA
26	023-0000-016	24831	TAPE COPPER 1/2 CONDUCTIVE CCH-36-101-0050	0.33	FT
27	023-0000-038	605160002	LATCH POST DIECAST SFP RETRACTABLE	4	EA
28	023-P110-004	NA	FERRULE INNER C3600 BRASS AMPHENOL	4	EA
29	023-S100-010	615280010	STRAIN RELIEF SHORT EMC 28G .190	4	EA
30	800-1221-004	486350004	SHK TBG 5/8 POLY ATUM BL RAYCHEM 4:1 SIZE 16/4	0.167	FT
31	800-0122-105	C1504105	SHK TBG 1/2 POLY AW BLK TAT-125-1/2-0	0.085	FT
32	023-0000-026	24848	TAPE COPPER 1 3/4" NON CONDUCTIVE CCH-36-301-0175	0.292	FT
33	527-4986-000	NA	ACD CUST BAG LABEL	1	EA

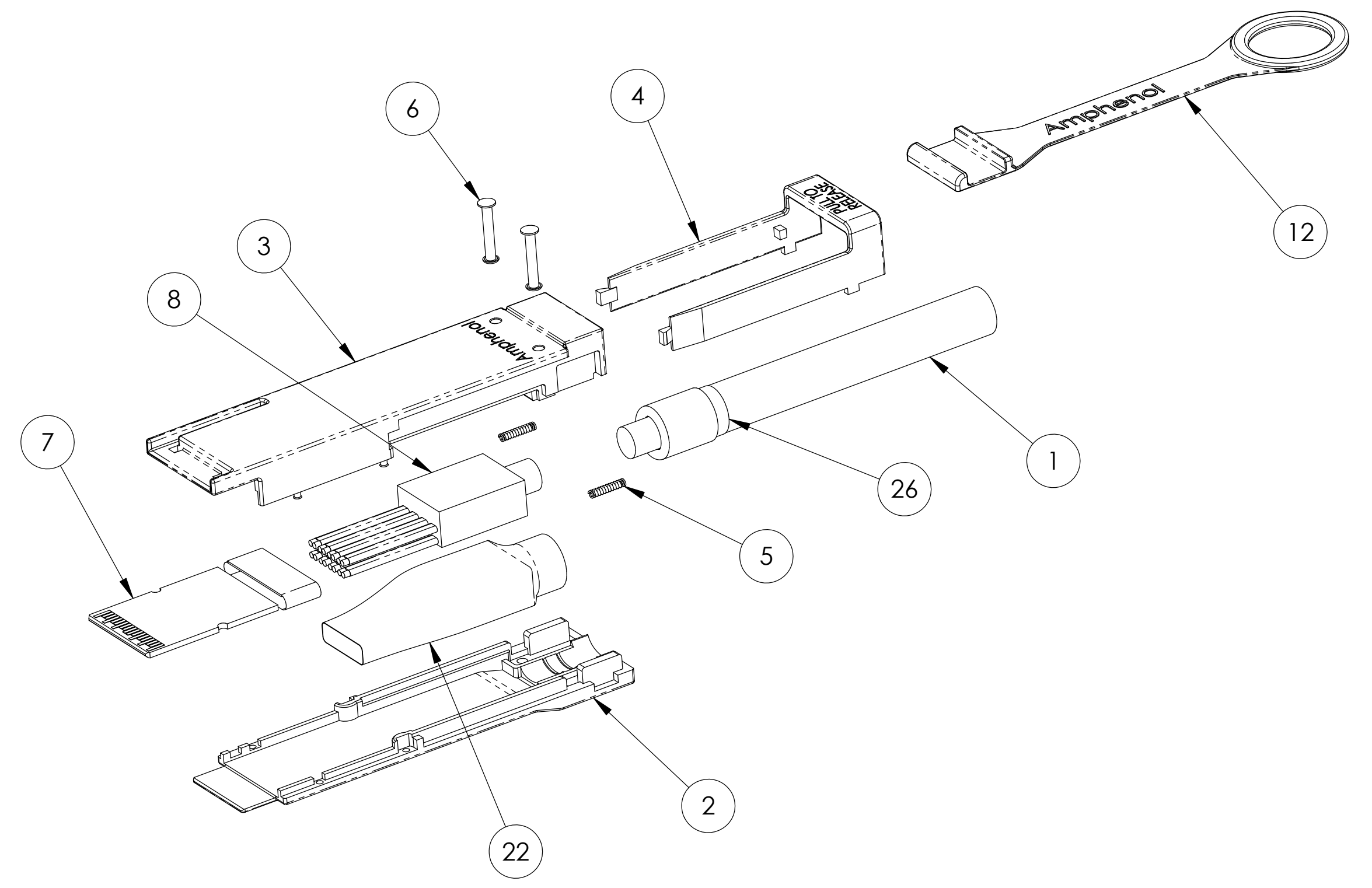

QSFP EXPLODED VIEW

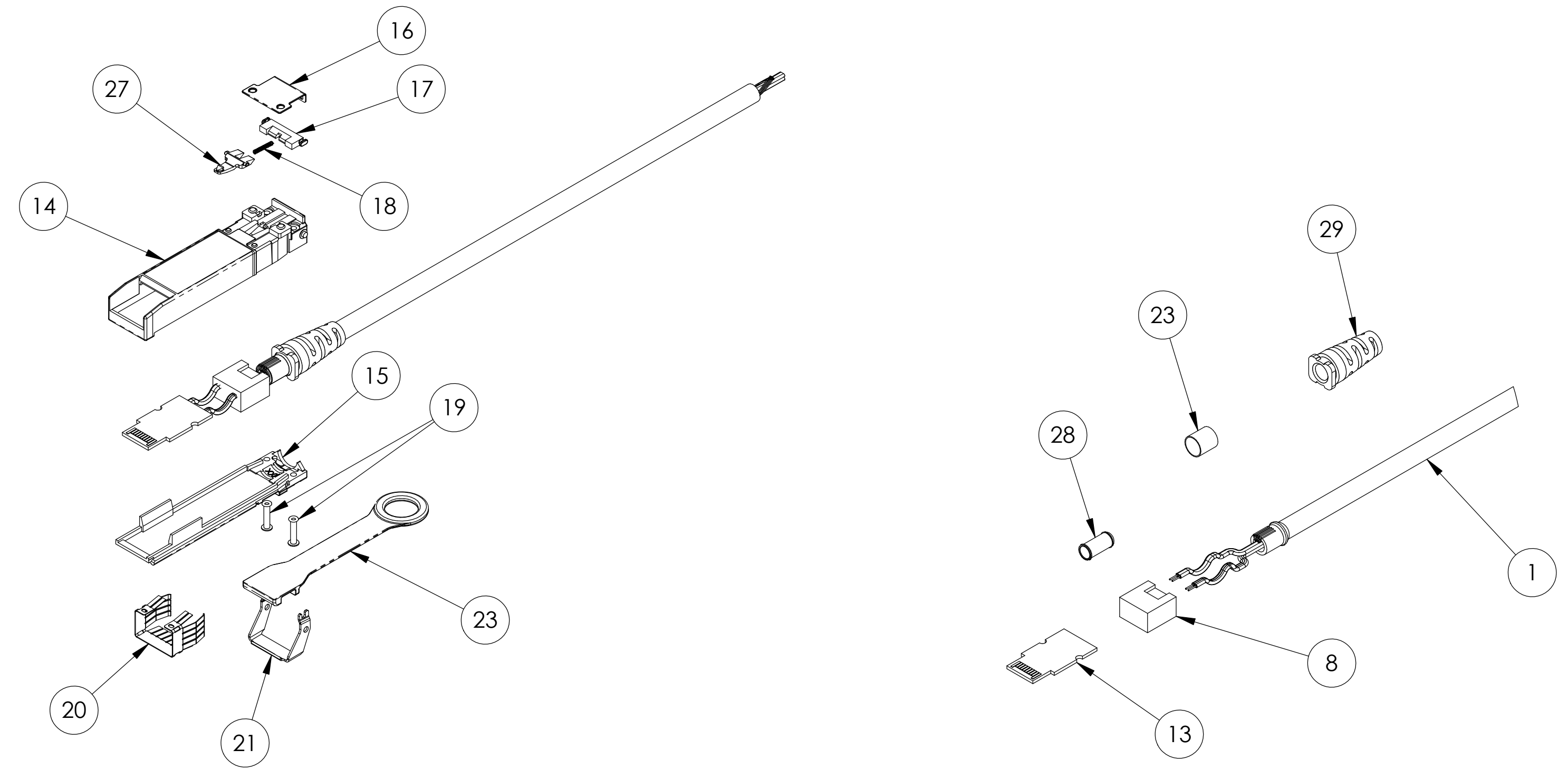

SFP+ EXPLODED VIEW

<p>INTERPRET PER ASME Y14.5</p> <p>CODE IDENT 31413</p>	<p>TOLERANCES</p> <p>0.0 ± 0.25</p> <p>0.00 ± 0.08</p> <p>±</p> <p>ANGLES ± 1.0°</p> <p>UNLESS OTHERWISE SPECIFIED DIMENSIONS ARE IN MM</p>	<p>APPROVED</p> <p>10/12/2015</p> <p>EM</p>	<p>DC</p> <p>DD</p>	<p>10/12/2015</p> <p>EM</p>	<p>APPROVED</p> <p>10/12/2015</p> <p>EM</p>	<p>DC</p> <p>DD</p>	<p>10/12/2015</p> <p>EM</p>	<p>DC</p> <p>DD</p>	<p>10/12/2015</p> <p>EM</p>
	<p>THESE DRAWINGS AND SPECIFICATIONS ARE THE PROPERTY OF AMPHENOL CORPORATION AND SHALL NOT BE REPRODUCED OR COPIED OR USED AS THE BASIS FOR THE MANUFACTURE OR SALE OF APPARATUS WITHOUT THE WRITTEN PERMISSION OF AMPHENOL CORPORATION</p>	<p>SEE TABLE 3</p> <p>P-NDAQGJ-C199</p>	<p>REV 1</p>						