



Chipsmall Limited consists of a professional team with an average of over 10 year of expertise in the distribution of electronic components. Based in Hongkong, we have already established firm and mutual-benefit business relationships with customers from,Europe,America and south Asia,supplying obsolete and hard-to-find components to meet their specific needs.

With the principle of “Quality Parts,Customers Priority,Honest Operation,and Considerate Service”,our business mainly focus on the distribution of electronic components. Line cards we deal with include Microchip,ALPS,ROHM,Xilinx,Pulse,ON,Everlight and Freescale. Main products comprise IC,Modules,Potentiometer,IC Socket,Relay,Connector.Our parts cover such applications as commercial,industrial, and automotives areas.

We are looking forward to setting up business relationship with you and hope to provide you with the best service and solution. Let us make a better world for our industry!



Contact us

Tel: +86-755-8981 8866 Fax: +86-755-8427 6832

Email & Skype: info@chipsmall.com Web: www.chipsmall.com

Address: A1208, Overseas Decoration Building, #122 Zhenhua RD., Futian, Shenzhen, China



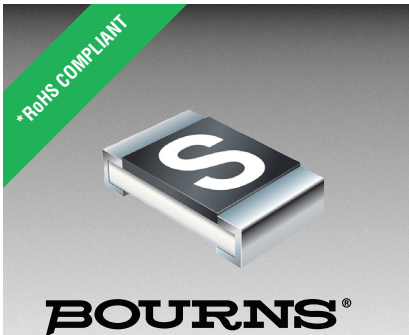

SinglFuse™ SF-1206SP Series Features

- Time lag thin film chip fuse for overcurrent protection
- 3216 (EIA 1206) miniature footprint
- Surface mount packaging for automated assembly
- UL listed (UL 248-14)
- RoHS compliant* and halogen free**

SF-1206SP Series - Time Lag Surface Mount Fuses

Electrical Characteristics

Model	Rated Current (Amps)	Fusing Time	Resistance (mΩ) Typ.***	Rated Voltage	Breaking Capacity	Typical I ² t (A ² s) ****
SF-1206SP050	0.50	Open within 1~120 sec. at 200 % rated current	738.5	DC 63 V	DC 63 V 50 A	0.027
SF-1206SP080	0.80		215			0.072
SF-1206SP100	1.00		163.5			0.134
SF-1206SP125	1.25		100			0.233
SF-1206SP150	1.50		68.5			0.305
SF-1206SP200	2.00		48.5			0.509
SF-1206SP250	2.50		35	0.777		
SF-1206SP300	3.00		27	1.285		
SF-1206SP400	4.00		14	2.374		
SF-1206SP500	5.00		11	5.510		
SF-1206SP700	7.00	7.5	10.170	DC 32 V	DC 32 V 50 A	

*** Resistance value measured with less than 10 % of rated current. Resistance tolerance ±25 %.

****Typical I²t value measured at 10x rated current.

Reliability Testing

Parameter	Requirement	Test Method
Carrying Capacity	No fusing	Rated current, 4 hours
Fusing Time	Within 120 seconds	200 % of its rated current
Interrupting Ability	No mechanical damages	After the fuse is interrupted, rated voltage applied for 30 seconds again
Bending Test	No mechanical damages	Distance between holding points: 90 mm, Bending: 3 mm, 1 time, 30 seconds
Resistance to Solder Heat	±20 %	260 °C ±5 °C, 10 seconds ±1 second
Solderability	95 % coverage minimum	235 °C ±5 °C, 2 ±0.5 second 245 °C ±5 °C, 2 ±0.5 second (lead free)
Temperature Rise	<75 °C	100 % of its rated current, measure of surface temperature
Resistance to Dry Heat	±20 %	105 °C ±5 °C, 1000 hours
Resistance to Solvent	No evident damage on protective coating and marking	23 °C ±5 °C of isopropyl alcohol, 90 seconds
Residual Resistance	10k ohms or more	Measure DC resistance after fusing
Thermal Shock	ΔR < 10 %	-20 °C / +25 °C / +125 °C / +25 °C, 10 cycles
UL File Number	E198545 http://www.ul.com/ Follow link to Online Certificates Directory, then enter UL File No. E198545, or click here	

Environmental Characteristics

Operating Temperature	-20 °C to +105 °C
Storage Conditions	
Temperature	+5 °C to +35 °C
Humidity	40 % to 75 %
Shelf Life	2 years from manufacturing date
Moisture Sensitivity Level	1
ESD Classification (HBM)	Class 6

BOURNS®

Asia-Pacific:

Tel: +886-2 2562-4117
Email: asiacus@bourns.com

Europe:

Tel: +36 88 520 390
Email: eurocus@bourns.com

The Americas:

Tel: +1-951 781-5500
Email: americus@bourns.com

www.bourns.com

* RoHS Directive 2015/863, Mar 31, 2015 and Annex.

** Bourns considers a product to be "halogen free" if (a) the Bromine (Br) content is 900 ppm or less; (b) the Chlorine (Cl) content is 900 ppm or less; and (c) the total Bromine (Br) and Chlorine (Cl) content is 1500 ppm or less.

"SinglFuse" is a trademark of Bourns, Inc.

Specifications are subject to change without notice.

The device characteristics and parameters in this data sheet can and do vary in different applications and actual device performance may vary over time. Users should verify actual device performance in their specific applications.

SinglFuse™ SF-1206SP Series Applications

- Portable memory
- LCD monitors
- Disk drives
- PDAs
- Digital cameras
- DVDs
- Cell phones
- Rechargeable battery packs
- Battery chargers
- Set top boxes
- Industrial controllers

SF-1206SP Series - Time Lag Surface Mount Fuses BOURNS®

Typical Part Marking

Represents total content. Layout may vary.



RATED CURRENT (A)	
F = 0.50	T = 2.50
K = 0.80	3 = 3.00
L = 1.00	W = 4.00
M = 1.25	Y = 5.00
P = 1.50	Z = 7.00
S = 2.00	

How to Order

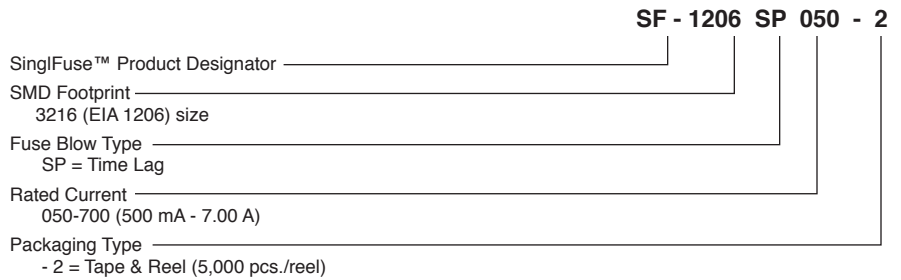

Solder Reflow Recommendations

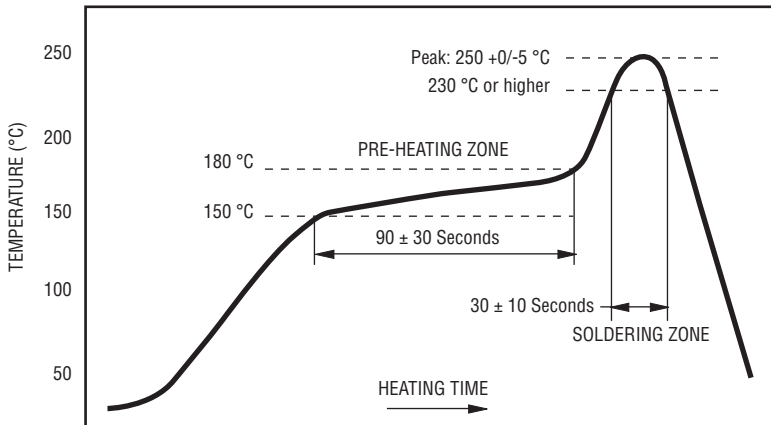

PEAK: 250 +0/-5 °C, 5 seconds
 PRE-HEATING ZONE: 150 to 180 °C, 90 ± 30 seconds
 SOLDERING ZONE: 230 °C or higher, 30 ± 10 seconds

Construction & Material Content

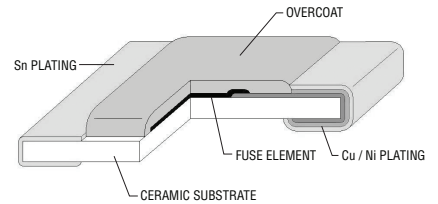

Product Dimensions

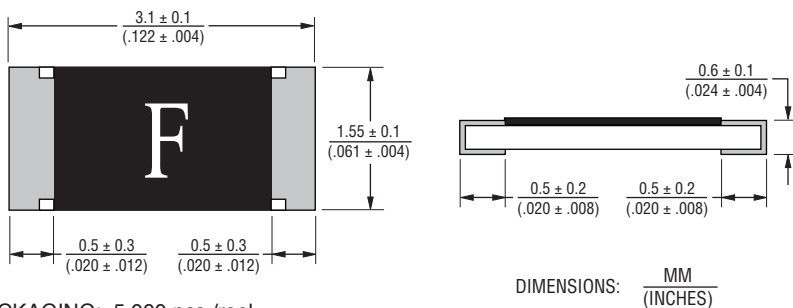

PACKAGING: 5,000 pcs./reel

Recommended Pad Layout

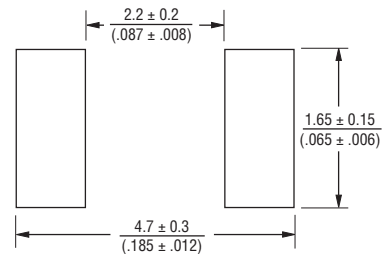

Specifications are subject to change without notice.
 The device characteristics and parameters in this data sheet can and do vary in different applications and actual device performance may vary over time.
 Users should verify actual device performance in their specific applications.

SF-1206SP Series - Time Lag Surface Mount Fuses



Average Time Current Curves

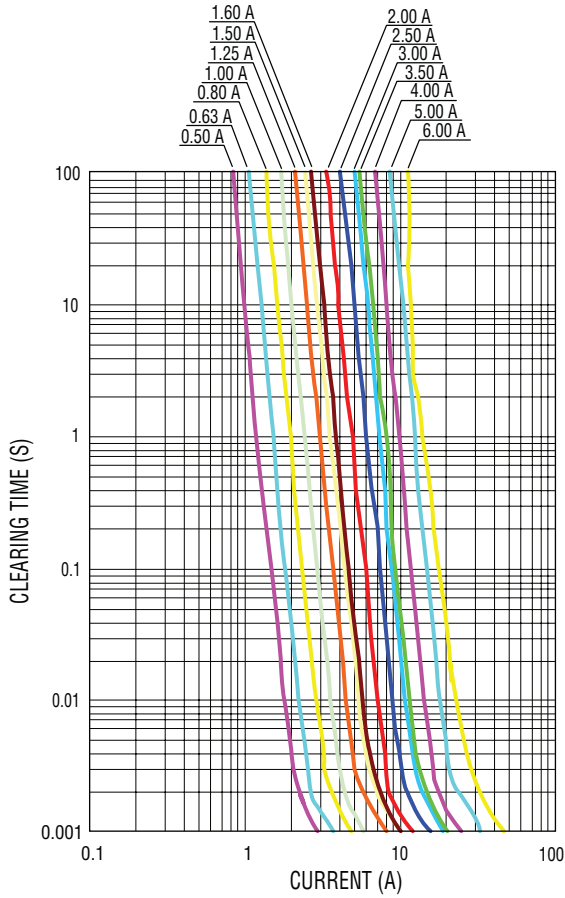

Minimum I²T V Clear Time Curves

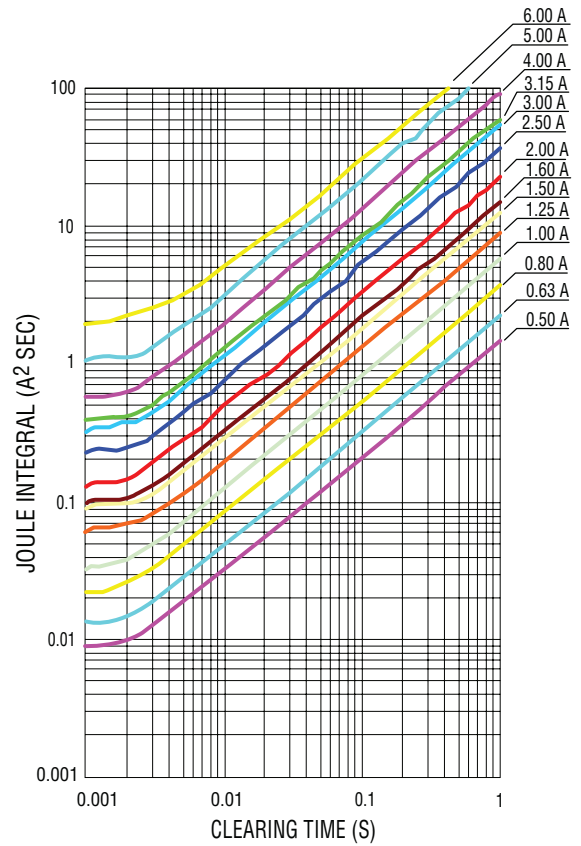

Thermal Derating Curve

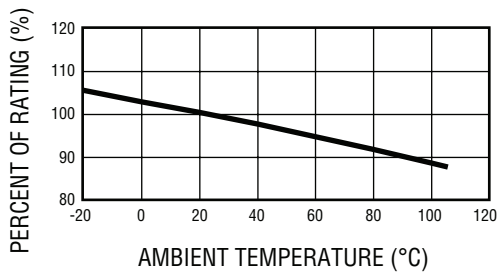

REV. A 08/17

Specifications are subject to change without notice.
 The device characteristics and parameters in this data sheet can and do vary in different applications and actual device performance may vary over time.
 Users should verify actual device performance in their specific applications.

SF-1206SP Series Tape and Reel Specifications

BOURNS®

Tape Dimensions	SF-1206SP Series per EIA 481-2
W	$\frac{8.0 \pm 0.2}{(.315 \pm .008)}$
P ₀	$\frac{4.0 \pm 0.1}{(.157 \pm .004)}$
P ₁	$\frac{4.0 \pm 0.1}{(.157 \pm .004)}$
P ₂	$\frac{2.0 \pm 0.05}{(.079 \pm .002)}$
A	$\frac{2.0 \pm 0.15}{(.079 \pm .006)}$
B	$\frac{3.6 \pm 0.2}{(.142 \pm .008)}$
F	$\frac{3.5 \pm 0.05}{(.138 \pm .002)}$
E	$\frac{1.75 \pm 0.1}{(.069 \pm .004)}$
D ₀	$\frac{1.5 + 0.1/-0}{(.059 + .004/-0)}$
T	$\frac{0.84 \pm 0.1}{(.033 \pm .004)}$
Reel Dimensions	
A	$\frac{178 \pm 0.2}{(7.087 \pm .079)}$
B Min.	$\frac{60.0 \pm 1.0}{(2.362 \pm .039)}$
C	$\frac{13.0 \pm 1.0}{(.512 \pm .039)}$
W	$\frac{9.0 \pm 1.0}{(.354 \pm .039)}$
T	$\frac{11.4 \pm 2.0}{(.449 \pm .079)}$

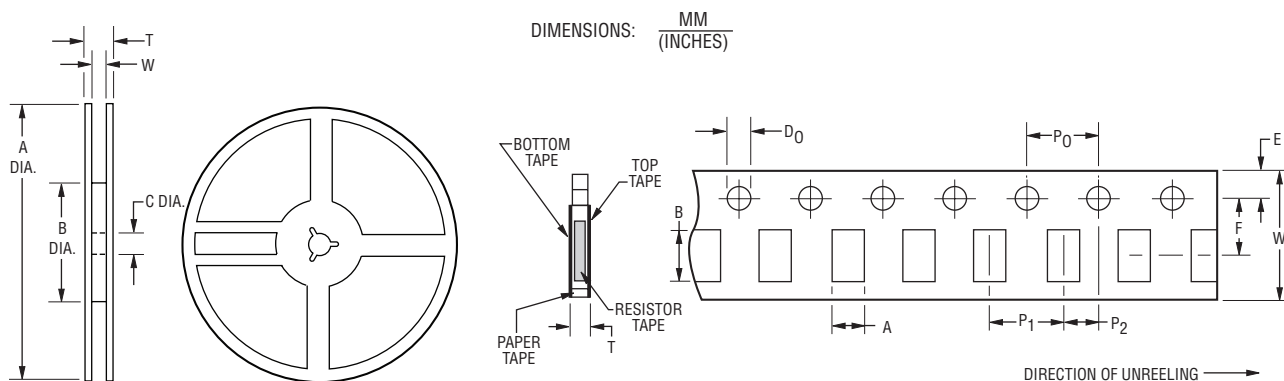

Specifications are subject to change without notice.
 The device characteristics and parameters in this data sheet can and do vary in different applications and actual device performance may vary over time.
 Users should verify actual device performance in their specific applications.