



Chipsmall Limited consists of a professional team with an average of over 10 year of expertise in the distribution of electronic components. Based in Hongkong, we have already established firm and mutual-benefit business relationships with customers from,Europe,America and south Asia,supplying obsolete and hard-to-find components to meet their specific needs.

With the principle of “Quality Parts,Customers Priority,Honest Operation,and Considerate Service”,our business mainly focus on the distribution of electronic components. Line cards we deal with include Microchip,ALPS,ROHM,Xilinx,Pulse,ON,Everlight and Freescale. Main products comprise IC,Modules,Potentiometer,IC Socket,Relay,Connector.Our parts cover such applications as commercial,industrial, and automotives areas.

We are looking forward to setting up business relationship with you and hope to provide you with the best service and solution. Let us make a better world for our industry!



## Contact us

Tel: +86-755-8981 8866 Fax: +86-755-8427 6832

Email & Skype: info@chipsmall.com Web: www.chipsmall.com

Address: A1208, Overseas Decoration Building, #122 Zhenhua RD., Futian, Shenzhen, China



# PRODUCT DATA DRAWING

REVISION HISTORY			
REV	DESCRIPTION	DATE	APPROVED
B	DCN 42455	06/16	STW

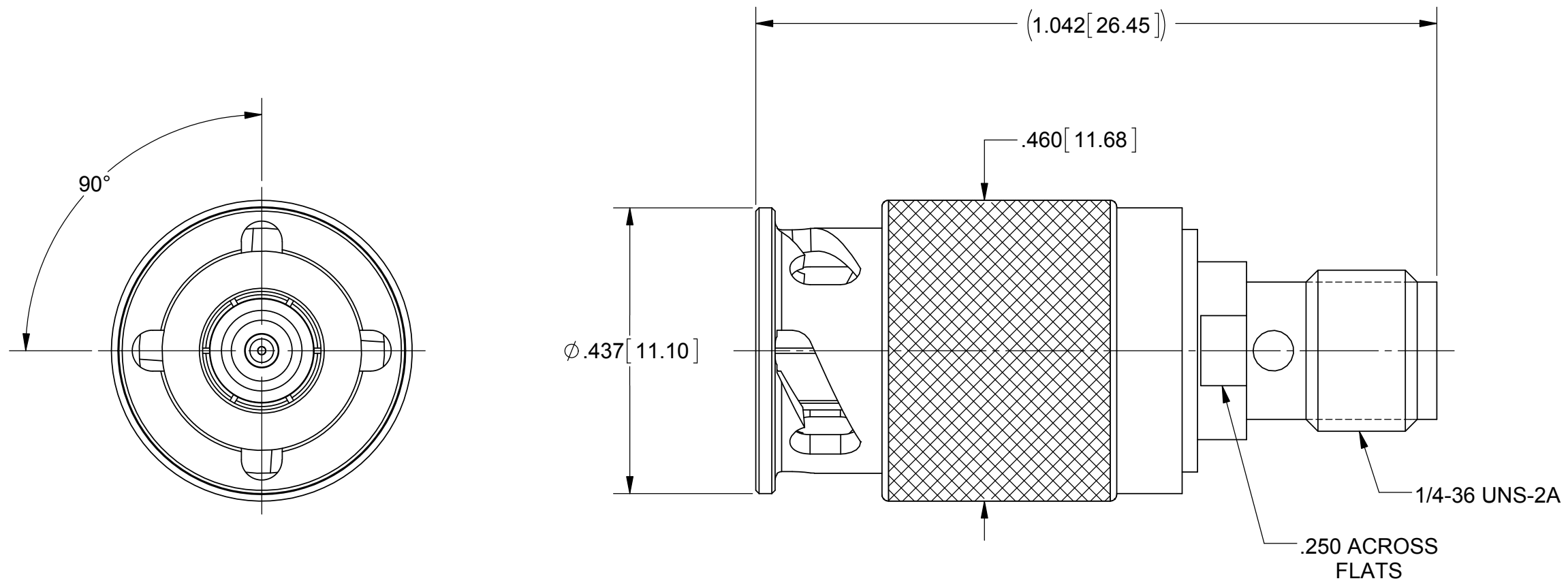

**MATERIAL:**

BODY,  
WASHERS &  
COUPLING NUT:

STAINLESS STEEL PER AMS-5640,  
ALLOY UNS S30300, TYPE 1; OR ASTM A582  
TYPE 303, COND A

LOCK RING &  
CONTACTS:

BERYLLIUM COPPER PER ASTM B196,  
ALLOY No. UNS C17300, TD04

SPRING:

17-7 PH STAINLESS STEEL

INSULATOR:

PTFE PER ASTM D1710, TYPE I, GRADE 1, CLASS B

**FINISH:**

BODY,  
WASHERS &  
COUPLING NUT:

PASSIVATED PER AMS-2700

CONTACTS:

GOLD PER ASTM B488, TYPE II,  
CODE C, CLASS .76, OVER NICKEL  
PER AMS-QQ-N-290, CLASS 1, .00003" MIN.

**PERFORMANCE:**

IMPEDANCE:  
FREQ. RANGE:

50 OHMS  
DC TO 12.4 GHz.

MATERIAL: SEE NOTES	DIMENSIONS ARE IN INCHES TOLERANCES: FRACTIONAL: ±1/64 ANGULAR: X° ±1'0" X°X' ±15'	UNLESS OTHERWISE SPECIFIED 1) ALL DIMENSIONS ARE IN INCHES (MILLIMETERS) 2) ALL DIMENSIONS ARE AFTER PLATING. 3) BREAK CORNERS & EDGES .005 R. MAX. 4) CHAM. 1ST & LAST THREADS. 5) SURFACE ROUGHNESS 63-MIL-STD-10. 6) DIA.'S ON COMMON CENTERS TO BE CONCENTRIC WITHIN .005 T.I.R. 7) REMOVE ALL BURRS	 2400 Centrepark West Drive, Suite 100 West Palm Beach, FL 33409 TITLE: SMA JACK TO 90° ZMA PLUG ADAPTER
FINISH: SEE NOTES	DECIMAL: X ±.030 .XX ±.010 .XXX ±.005	INTERPRET DIMENSIONS AND TOLERANCES PER ASME Y14.5M - 1994	
SURFACE AREA: N/A	THIRD ANGLE PROJECTION	DRAWN: VMJ 12/03/98	SIZE: B CAGE CODE: 95077 DWG. NO.: SF1122-6031
PROPRIETARY THE INFORMATION CONTAINED IN THIS DRAWING IS THE SOLE PROPERTY OF SV MICROWAVE, INC. ANY REPRODUCTION IN PART OR AS A WHOLE WITHOUT THE WRITTEN PERMISSION OF SV MICROWAVE, INC IS PROHIBITED.		CHECKED: JM 12/04/98	SCALE: 5:1
		APPROVED: JM 12/04/98	SHEET 1 OF 1