



Chipsmall Limited consists of a professional team with an average of over 10 year of expertise in the distribution of electronic components. Based in Hongkong, we have already established firm and mutual-benefit business relationships with customers from,Europe,America and south Asia,supplying obsolete and hard-to-find components to meet their specific needs.

With the principle of “Quality Parts,Customers Priority,Honest Operation,and Considerate Service”,our business mainly focus on the distribution of electronic components. Line cards we deal with include Microchip,ALPS,ROHM,Xilinx,Pulse,ON,Everlight and Freescale. Main products comprise IC,Modules,Potentiometer,IC Socket,Relay,Connector.Our parts cover such applications as commercial,industrial, and automotives areas.

We are looking forward to setting up business relationship with you and hope to provide you with the best service and solution. Let us make a better world for our industry!



Contact us

Tel: +86-755-8981 8866 Fax: +86-755-8427 6832

Email & Skype: info@chipsmall.com Web: www.chipsmall.com

Address: A1208, Overseas Decoration Building, #122 Zhenhua RD., Futian, Shenzhen, China



図面番号 (DRAWING NO.) SJ115712

版数 VER.	年月日 DATE	CN NO.	変更内容 DESCRIPTION	製図 DR.	担当 CHK.	査閲 APPD.	承認 APPD.
2	29/JAN/2015	011160	Version No. added		K. MIKAWA	M. SHIMADA	A. NATORI

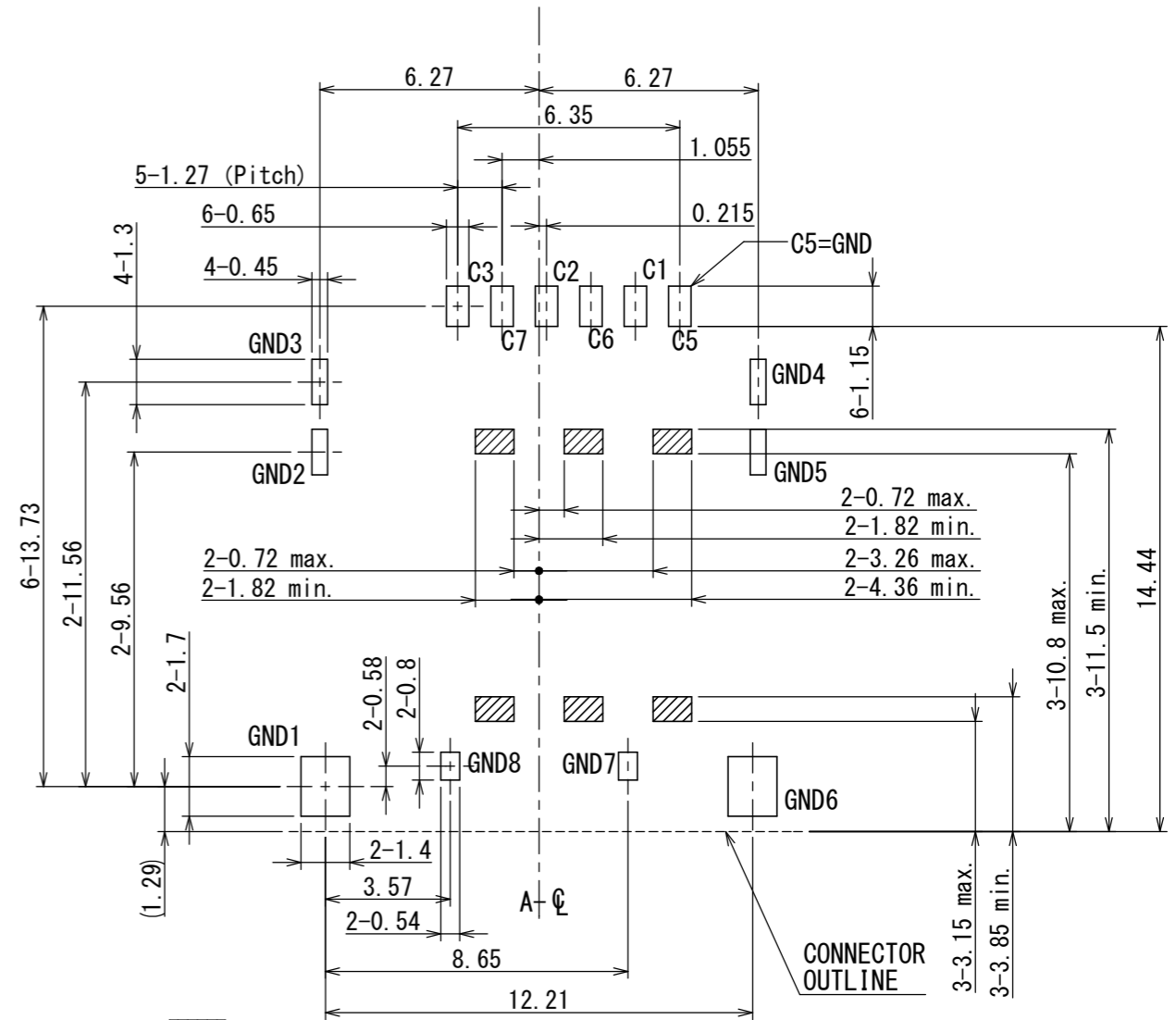
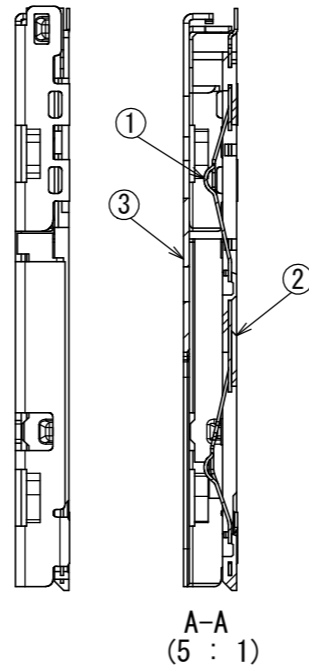
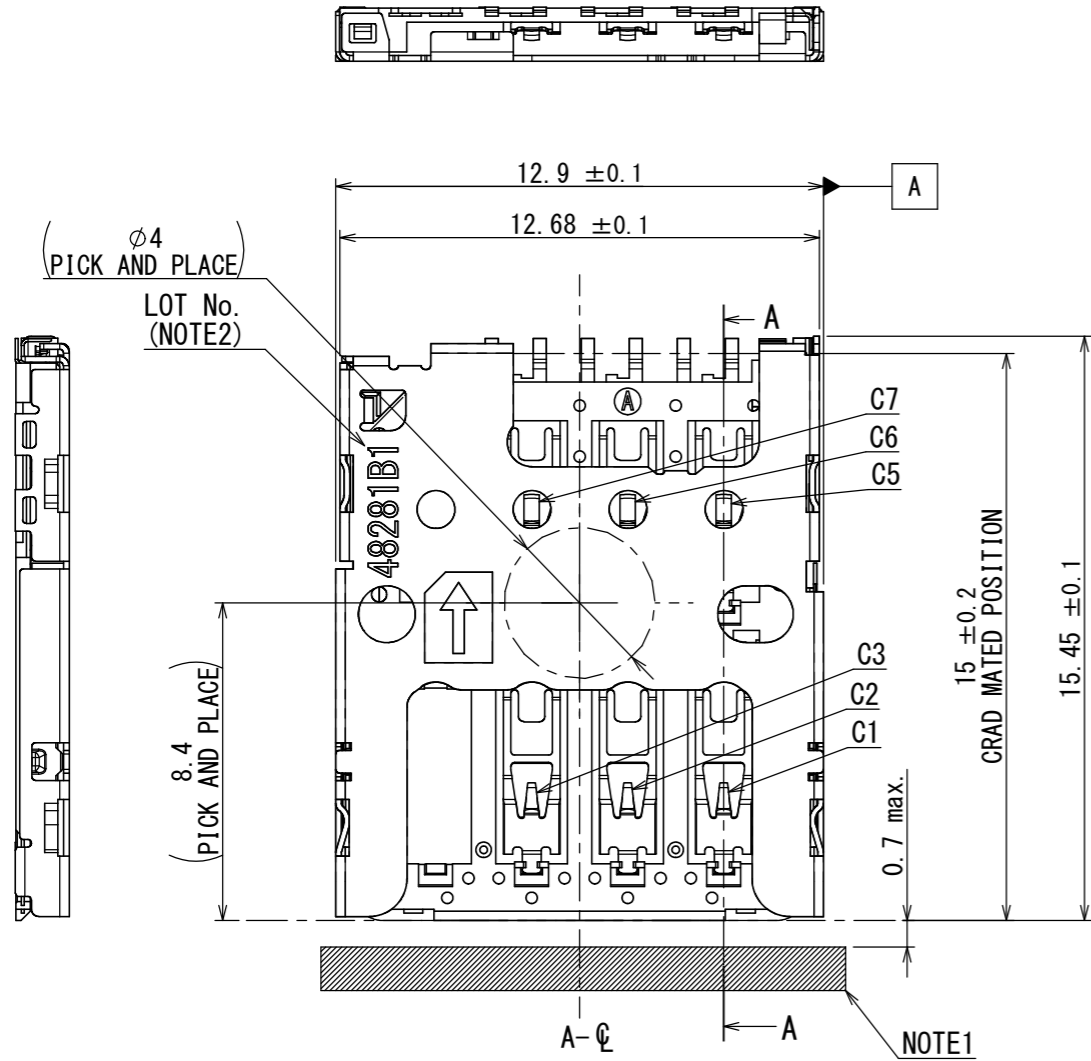

RESTRICTED AREA (No pattern and Via hole)

All patterns and Via holes under the connector should be coated by resist.

Recommended P.C.B Layout

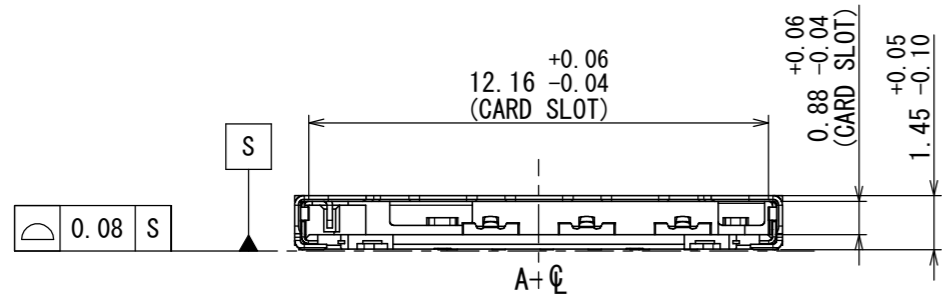

NOTE1. CARD STOPPER POSITION
NOTE2. LOT INFORMATION IS SHOWN AS BELOW.
i. e. 4 8 2 8 1 B 1

VERSION NO. (B1 or V*)
PRODUCTION LINE NO.
PRODUCT DATE (YMDD)

符号 NO.	名称 DESCRIPTION	個数 QTY.	材料 MATERIAL	仕上 FINISH	備考 REMARKS
3	COVER	1	STAINLESS	TERMINAL AREA : Au OVER Ni	-
2	INSULATOR	1	GLASS FILLED LCP	-	-
1	CONTACT	6	COPPER ALLOY	CONTACT AREA : Au OVER Ni TERMINAL AREA : Au OVER Ni	-

仕様書 (SPECIFICATION) JACS-11066*	第1版 (ORIGINAL DATE) 06/OCT/2014	尺度 (SCALE) 5:1	シリーズ (SERIES) SF53	日本航空電子工業株式会社	SIZE A3
一般公差 (GENERAL TOLERANCE) 寸法 (DIMENSION) × ± 0.8 ×× ± 0.4 ××× ± 0.1 ×××× ±	角度 (ANGLES) ×° ± ×°×' ±	製造 DR. 担当 CHK. K. MIKAWA 査閲 APPD. M. SHIMADA 承認 APPD. A. NATORI	名称 (TITLE) SF53S006VCB	JAE JAPAN AVIATION ELECTRONICS INDUSTRY, LTD.	
質量 (MASS) -				図面番号 (DRAWING NO.) SJ115712	版数 (VER.) 2