



Chipsmall Limited consists of a professional team with an average of over 10 year of expertise in the distribution of electronic components. Based in Hongkong, we have already established firm and mutual-benefit business relationships with customers from,Europe,America and south Asia,supplying obsolete and hard-to-find components to meet their specific needs.

With the principle of “Quality Parts,Customers Priority,Honest Operation,and Considerate Service”,our business mainly focus on the distribution of electronic components. Line cards we deal with include Microchip,ALPS,ROHM,Xilinx,Pulse,ON,Everlight and Freescale. Main products comprise IC,Modules,Potentiometer,IC Socket,Relay,Connector.Our parts cover such applications as commercial,industrial, and automotives areas.

We are looking forward to setting up business relationship with you and hope to provide you with the best service and solution. Let us make a better world for our industry!



Contact us

Tel: +86-755-8981 8866 Fax: +86-755-8427 6832

Email & Skype: info@chipsmall.com Web: www.chipsmall.com

Address: A1208, Overseas Decoration Building, #122 Zhenhua RD., Futian, Shenzhen, China



Ideal for quick installation of the Light Curtain!

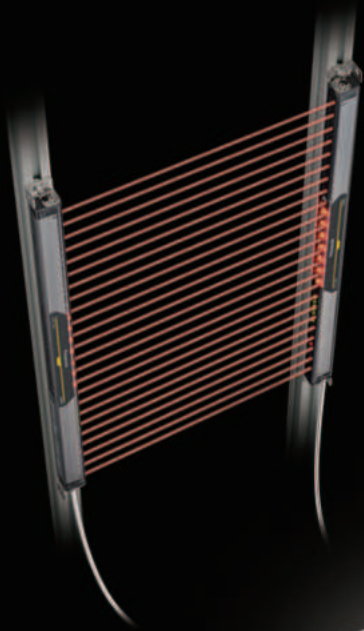

**Quick connection!
Reduce miswiring!**



Conventional way Require to connect total **24 wires**

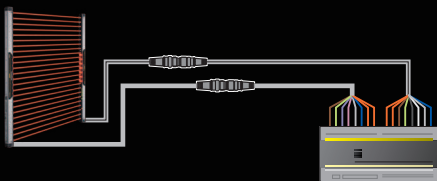

Safety PLC, Safety Relay Unit,
SF-C13, SFL, SF-CL1T264T, etc.

Y-shaped connector Connect **only 5 wires**
plus 2 wires for large multipurpose indicator

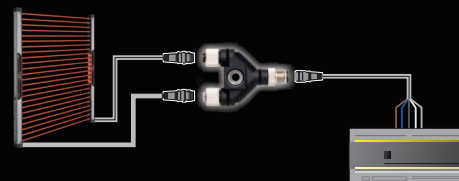

Safety PLC, Safety Relay Unit,
SF-C13, SFL, SF-CL1T264T, etc.

Connector pin assignment

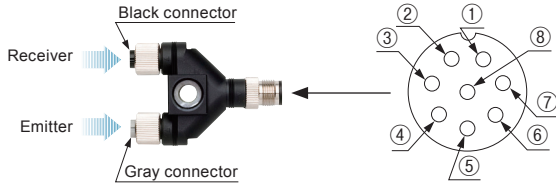

Connector pin		Description
No.	Color (WY1-CCN□)	
①	White	Control output 2 (OSSD2)
②	Brown	+24 V
③	Black	Control output 1 (OSSD1)
④	Yellow-green	Not in use
⑤	Gray	Emitter side large multipurpose indicator
⑥	Gray / Black	Receiver side large multipurpose indicator
⑦	Blue	0 V
⑧	Shield	Output polarity setting

Type	Appearance	Model No.	Description
Wire saving Y-shape connector		SFBC-WY1-T1	Wire saving connector for SF4B-A□-C-J05 and SF4B-H□-C-J05 . Consolidates cables of the emitter and the receiver into one for wire saving. Wiring has only +24 V, 0 V, OSSD1, OSSD2, output polarity setting (shield cable), the emitter side large multipurpose indicator and the receiver side large multipurpose indicator. [Power wires and synchronization wires are connected inside of the connector.] Interlock function is disabled (auto-reset) if using this wire saving connector.
Cable with connector on one end		WY1-CCN3	Cable length: 3 m 9.843 ft Net weight: Approx. 200 g (1 cable)
		WY1-CCN10	Cable length: 10 m 32.808 ft Net weight: Approx. 620 g (1 cable)
Cable with connectors on both ends		SFB-CCJ3E-MU	Cable length: 3 m 9.843 ft Net weight: Approx. 190 g (1 cable)
		SFB-CCJ10E-MU	Cable length: 10 m 32.808 ft Net weight: Approx. 660 g (1 cable)
		SFB-CCJ3D-MU	Cable length: 3 m 9.843 ft Net weight: Approx. 210 g (1 cable)
		SFB-CCJ10D-MU	Cable length: 10 m 32.808 ft Net weight: Approx. 680 g (1 cable)
			Exclusive cable for the Y-shaped connector Cable jacket color: Gray with black line Connector color: Black Minimum bending radius: R6 mm R0.236 in.
			Cable with connectors on both ends for pigtailed type (with muting function). Cable jacket color: Gray (for the emitter) Gray with black line (for the receiver) Connector color: Gray (for the emitter) Black (for the receiver) Minimum bending radius: R6 mm R0.236 in.

Wiring diagram: SF-C13 control unit

For PNP output (minus to ground)

- Connect the control output 1 (OSSD1) to S1 and the control output 2 (OSSD2) to S2.

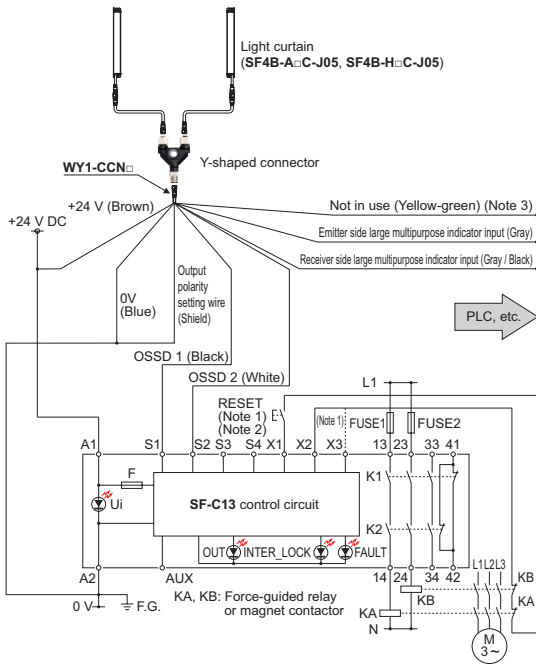

- Notes: 1) The above design is when using manual reset. If automatic reset is used, disconnect the lead wire from X2 and connect it to X3. In this case, a reset (RESET) button is not needed.
2) Use a momentary-type switch as the reset (RESET) button.
3) Unused wires must be insulated.

For NPN output (plus to ground)

- Connect the control output 1 (OSSD1) to S4 and the control output 2 (OSSD2) to S2.

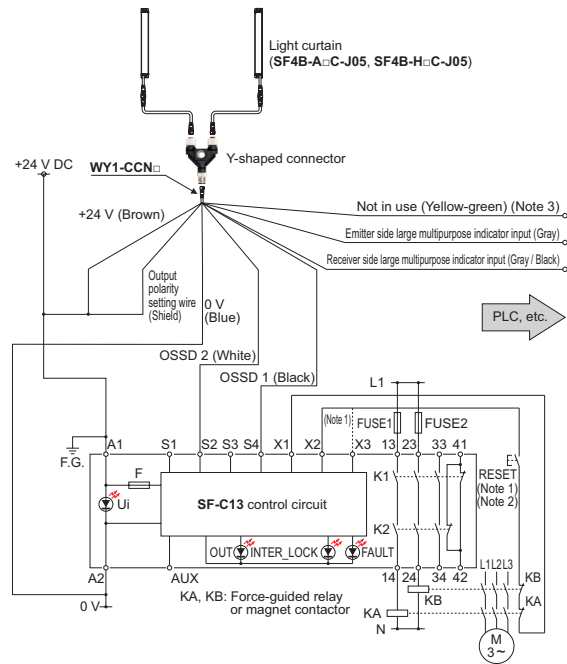

- Notes: 1) The above design is when using manual reset. If automatic reset is used, disconnect the lead wire from X2 and connect it to X3. In this case, a reset (RESET) button is not needed.
2) Use a momentary-type switch as the reset (RESET) button.
3) Unused wires must be insulated.