



Chipsmall Limited consists of a professional team with an average of over 10 year of expertise in the distribution of electronic components. Based in Hongkong, we have already established firm and mutual-benefit business relationships with customers from,Europe,America and south Asia,supplying obsolete and hard-to-find components to meet their specific needs.

With the principle of “Quality Parts,Customers Priority,Honest Operation,and Considerate Service”,our business mainly focus on the distribution of electronic components. Line cards we deal with include Microchip,ALPS,ROHM,Xilinx,Pulse,ON,Everlight and Freescale. Main products comprise IC,Modules,Potentiometer,IC Socket,Relay,Connector.Our parts cover such applications as commercial,industrial, and automotives areas.

We are looking forward to setting up business relationship with you and hope to provide you with the best service and solution. Let us make a better world for our industry!



## Contact us

Tel: +86-755-8981 8866 Fax: +86-755-8427 6832

Email & Skype: info@chipsmall.com Web: www.chipsmall.com

Address: A1208, Overseas Decoration Building, #122 Zhenhua RD., Futian, Shenzhen, China



# Ambient Light and Proximity Sensor with Integrated 940nm IR Emitter Version 1.3

---

## SFH 7779



### Features:

- Proximity sensor (PS)
  - Detection range up to 160 mm
  - 940 nm IR emitter integrated in package
  - Programmable pulse current up to 200 mA
  - No separator needed if placed <0.4mm behind glass window, window thickness<1.0 mm
- Ambient light sensor (ALS)
  - detection range 0.0022 - 73000 lx;
  - 50Hz/60Hz flicker noise suppression
- I<sup>2</sup>C interface (max. 400kHz)
- PS and ALS Interrupt function
- Current consumption
  - typ. 0.8μA in Standby mode
  - typ 90μA for ALS operation
  - typ 60μA for PS operation
- Miniature package 4mm x 2.1mm x 1.35mm

### Applications

- Mobile phones
- PDAs- and notebooks
- Cameras
- Consumer products

### Ordering Information

Type:	Ordering Code
SFH 7779	Q65111A4810

## Application diagram

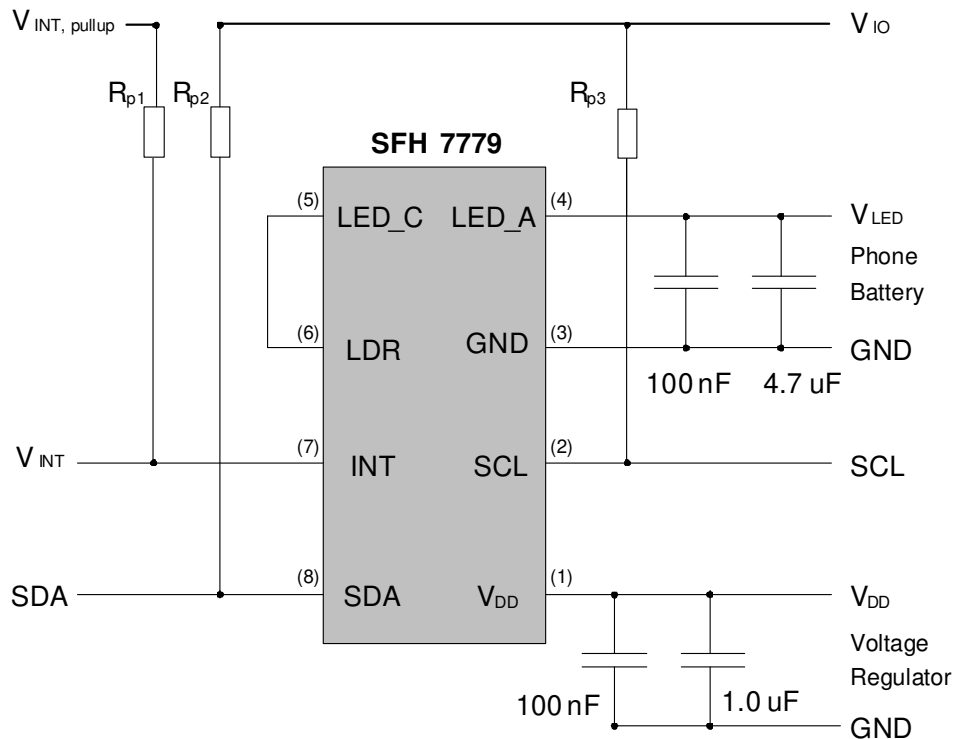

- Bypass capacitors for VDD and VLED are required for proper operation of the device.
- Proposed size for the pull-up resistors Rp1, Rp2 and Rp3 are 10kOhm

## Pin description

Pin	Name	Function
1	V <sub>DD</sub>	Power supply pin
2	SCL	I <sup>2</sup> C bus serial clock pin
3	GND	Ground pin
4	LED_A	Anode of the LED
5	LED_C	Cathode of the LED
6	LDR	LED driver pin
7	INT	Interrupt pin; open drain output; configured via I <sup>2</sup> C bus
8	SDA	I <sup>2</sup> C bus serial data pin

## Short Evaluation program

Adress	Command	Action
0x42	0x3F	set LED pulse current to 200mA and ALS gain to x128
0x41	0x06	activate ALS & PS with a measurement repetition time of 100ms
Wait 100ms		
0x44	read data	read LSB of proximity measurement data
0x45	read data	read MSB of proximity measurement data
0x46	read data	read LSB of ambient light measurement of VIS diode
0x47	read data	read MSB of ambient light measurement of VIS diode
0x48	read data	read LSB of ambient light measurement of IR diode
0x49	read data	read MSB of ambient light measurement of IR diode

I<sup>2</sup>C interface

- I/O-pins are open drain type and logic high level is set with external pull-up resistor
- SFH 7779 operates in slave mode. Slave address is 0111001 (0x39h)
- Designed for the I<sup>2</sup>C Fast mode (400 kb/s)
- Interrupt pin (INT): open-drain output (like SDA and SCL)

## Block diagram

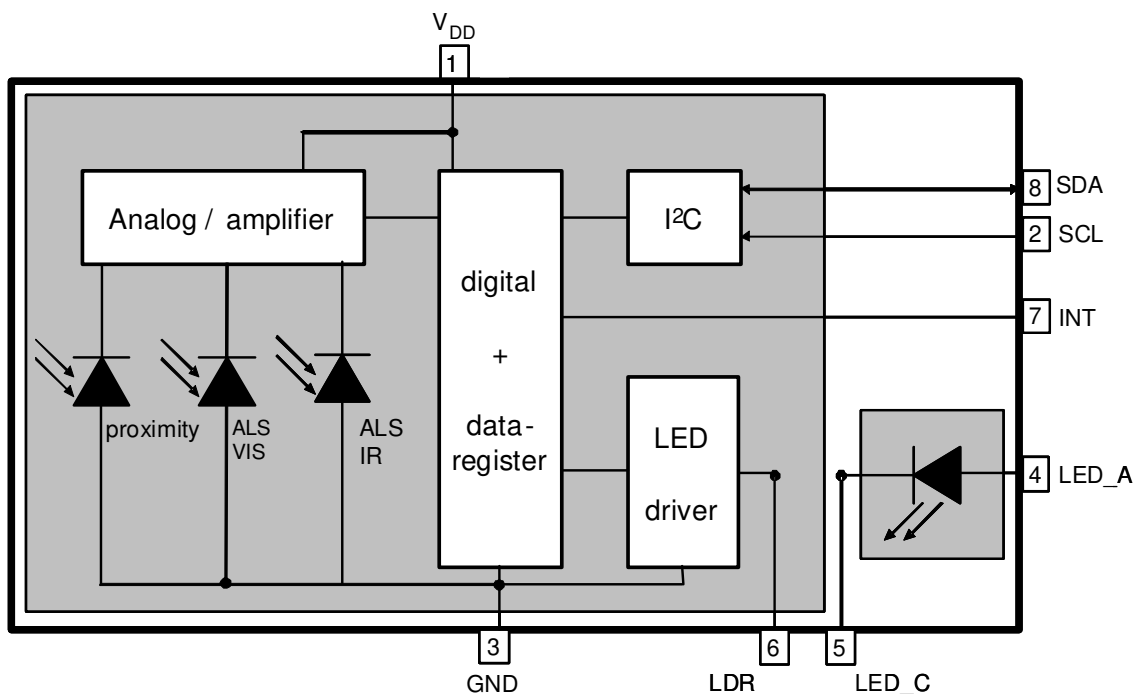



## Measurement modes

Mode	Description
OFF	The device is inactive. Other units may use the I <sup>2</sup> C bus without any restrictions; I/O pins and INT are in high Z state. There is no sink current through the LED
STAND-BY	This is the initial mode after power-up. $I_{DD}$ is typ. 0.8 $\mu$ A. No measurement is performed. Device can be activated by I <sup>2</sup> C bus communication. Data registers can be read and written.
ALS / PS free - RUNNING	Measurements are triggered internally by the SFH 7779. Stand-by / active mode for ALS and PS, measurement times, interrupt options and LED current can be adjusted via I <sup>2</sup> C register. Measurement results can be read from the data register, the status from the interrupt register.

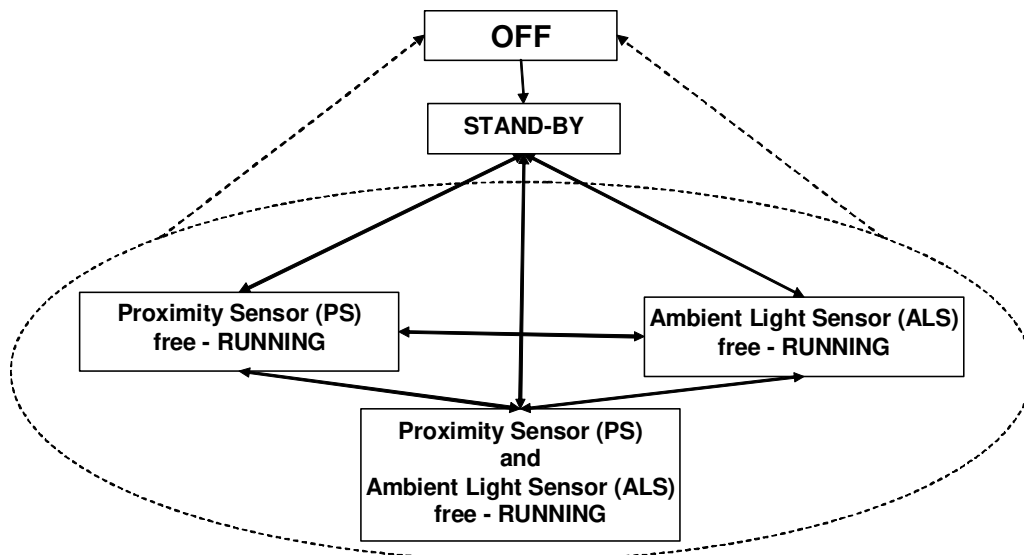

If  $V_{DD}$  exceeds the threshold voltage, the sensor will switch from OFF mode to STAND-BY mode. As shown in the transition-diagram above it is possible to switch between all modes without any restriction.

**Maximum Ratings** ( $T_A = 25\text{ °C}$ )

Parameter	Symbol	Values	Unit
Storage temperature range	$T_{stg}$	-40 ... 100	°C
Operating temperature range	$T_{op}$	-40 ... 85	°C
Maximum supply voltage (between $V_{DD}$ and GND)	$V_{DD}$	4.5	V
Maximum voltage of SDA, SCL to GND	$V_{dig}$	4.5	V
Maximum voltage of INT to GND	$V_{int}$	7	V
Maximum voltage of VLED to GND	$V_{LED}$	7	V
Maximum Current of INT and SDA	$I_{INT} / I_{SDA}$	7	mA
ESD withstand voltage (acc. to ANSI / ESDA JEDEC JS-001-HBM)	$V_{ESD}$	2	kV

Operating conditions ( $T_A = 25\text{ °C}$ )

Parameter	Symbol	Value			Unit
		min.	typ.	max.	
Supply voltage	$V_{DD}$	2.3	2.5	3.6	V
Ripple on supply voltage ( $V_{DDmin}$ and $V_{DDmax}$ must stay in the $V_{DD}$ range, DC ... 100MHz)	$V_{DD,rip}$			200	mV
VDD threshold voltage (voltage to initiate the start-up procedure)	$V_{DD; th}$		1.7	2.3	V
Voltage for INT	$V_{INT}$			5.5	V
Voltage for SCL and SDA	$V_{SCL}$ $V_{SDA}$	1.65		3.6	V
SDA and SCL input low level voltage	$V_{SCL\_low}$ $V_{SDA\_low}$			0.54	V
SDA and SCL input high level voltage	$V_{SCL\_high}$ $V_{SDA\_high}$	1.26			V
SDA and SCL input current	$I_{SCL\_low}$ $I_{SDA\_low}$	-10		10	$\mu\text{A}$
INT output low level voltage ( $I_{INT} = 3\text{ mA}$ ) (When INT is active: $V_{INT} = \text{low}$ when INT is inactive: $V_{INT} = \text{high}$ )	$V_{INT\_low}$			0.4	V
Supply voltage LED <sup>1)</sup>	$V_{LED}$	2.3	3.5	5.5	V
Ripple VLED	$V_{LED,rip}$			200	mV

<sup>1)</sup>2.3 V is only valid for an LED current setting up to 100mA; If the sensor is driven with LED currents >100mA the VLED voltage should be higher than 3.0V.

**Characteristics** ( $T_A = 25\text{ °C}$ )

Parameter	Symbol	Value			Unit
		min.	typ.	max.	

**General**

Conditions for OFF mode	$V_{DD,off}$		0.5		V
Current consumption in OFF mode ( $V_{DD} < 0.5V$ )	$I_{DD,off}$		0		$\mu A$
STAND-BY mode current consumption (Mode_control(41h) = 0x00; $V_{DD} = 2.5V$ )	$I_{DD,stby}$		0.8	1.5	$\mu A$

**Proximity Sensor (PS)**

LED centroid wavelength ( $I_{LED} = 100mA$ )	$\lambda_{centroid}$		940		nm
LED Spectral bandwidth ( $I_{LED} = 100mA$ )	$\Delta\lambda$		30		nm
Temperature coefficient of optical power of LED	TC		-0.5		%/K
ILED ON time for one measurement	$t_{LED\ ON}$	80	200	300	$\mu s$
LED current, programmable $V_{LED} > 2.3V$ for $I_{LED} < 100mA$ $V_{LED} > 3.0V$ for $I_{LED} > 100mA$	$I_{LED}$	25		200	mA
Accuracy of LED current source (ALS_PS_CONTROL: LED Current = 00b)	$I_{LED}$	22.5	25	27.5	mA
Mean current consumption in PS mode (current consumption of the pulsed LED is not included; MODE_CONTROL(0x41h) = 0x03h; all other registers are default; $V_{DD} = 2.5V$ )	$I_{DD}$		60	150	$\mu A$
Mean current consumption in PS mode during the 200 $\mu s$ LED pulse ( $t_{LED\ ON}$ ) (current consumption of the pulsed LED is not included)	$I_{DD}$		6.5	8.5	mA
Typical detection distance <sup>1)</sup> KODAK grey card 100x130mm <sup>2</sup> , R=90% ( $I_{LED}=200mA$ , $V_{DD}=2.5V$ , $E_v = 0lx$ ; high threshold = 11 counts)	$h_{on}$		10		cm



Typical none detection distance <sup>1)</sup> KODAK grey card 100x130mm <sup>2</sup> , R=90% ( $I_{LED}=200\text{mA}$ , $V_{DD}=2.5\text{V}$ , $E_v = 0\text{lx}$ low threshold = 8 counts)	$h_{\text{off}}$		12		cm
PS sensor output with human skin reflector ( $I_{LED}=200\text{mA}$ , $V_{DD}=2.5\text{V}$ , $h=0\text{mm}$ : skin directly on top of the sensor)	$PS_{\text{out}}$		850		counts
Temperature coefficient of the PS signal ( $I_{LED}=200\text{mA}$ , $V_{DD}=2.5\text{V}$ , R=90%, $A_{\text{Reflector}} = 10 \times 13 \text{cm}^2$ , $h=4\text{cm}$ )	$TK_{PS}$		0.15		%/K

### 1) Example of PS Hysteresis

The switching distance  $h$  is specified from top sensor surface to the reflector.

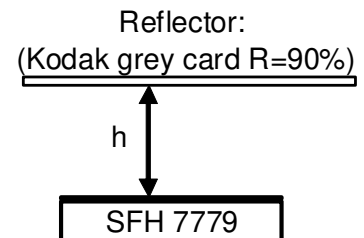
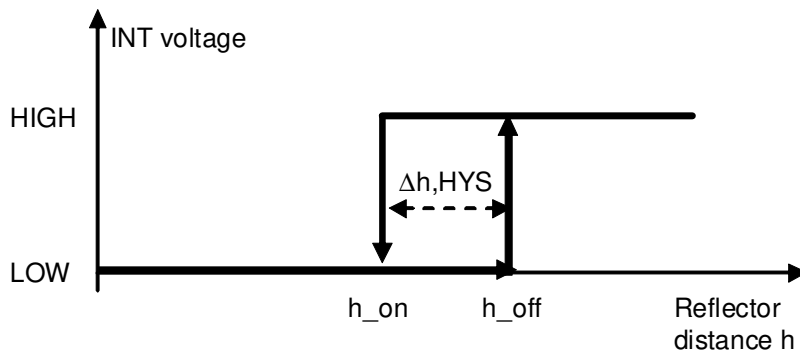

**Dimensions of proposed optical aperture**

(optical aperture: IR transmitting opening in cover glass)

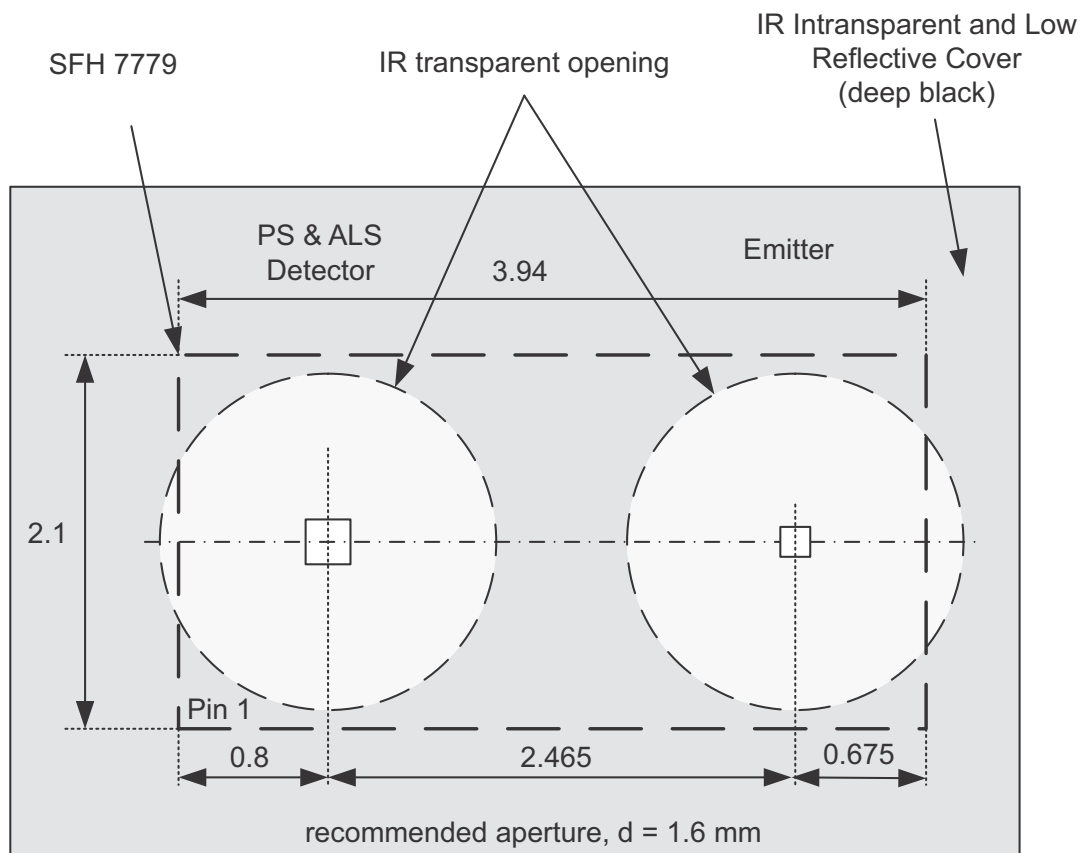
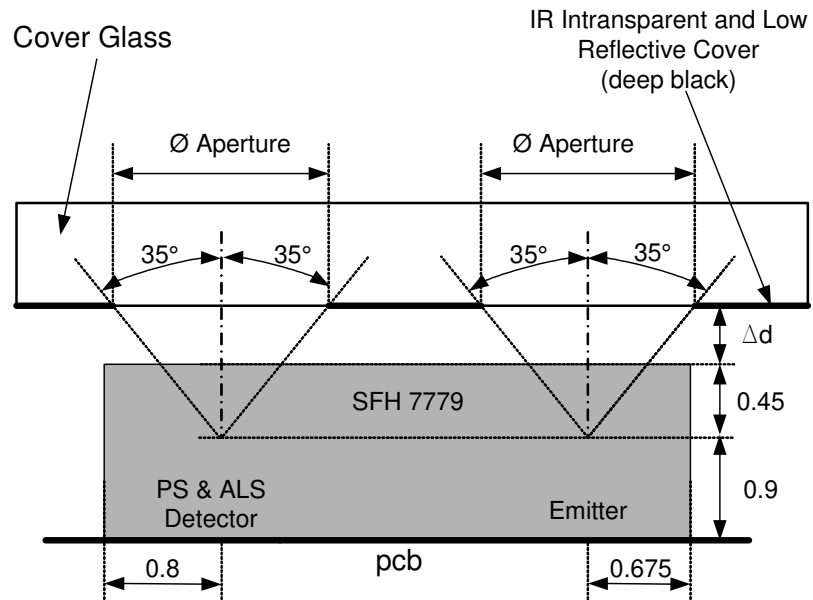

Dimensions in mm

**Characteristics** (T<sub>a</sub> = 25°C)

Parameter	Symbol	Value			Unit
		min.	typ.	max.	

**Ambient Light Sensors: ALS VIS and ALS IR diode**

Wavelength of max. sensitivity for ALS VIS	$\lambda S_{\max}$		560		nm
Spectral range of sensitivity (10% of S <sub>max</sub> ) of ALS VIS	$\lambda S_{10\%}$	450		950	nm
Wavelength of max. sensitivity of ALS IR	$\lambda S_{\max}$		880		nm
Spectral range of sensitivity (10% of S <sub>max</sub> ) of ALS IR	$\lambda S_{10\%}$	830		1050	nm
Illuminance measurement range is programmable (the maximum ALS sensitivity can be reached with the ALS high sensitivity mode --> 400ms ALS integration time) (MODE_CONTROL (0x41h) = 0Ah or 0Bh)		0.0022		73000	lx
ALS VIS sensor output (1000lx; white LED; V <sub>DD</sub> = 2.5V) ((MODE_CONTROL (0x41h) = 08h) (ALS_PS_CONTROL (0x42h): Gain = X1)	ALS <sub>VIS_out</sub>	750	900	1080	counts
ALS IR sensor output (324μW/cm <sup>2</sup> ; IRED 850 nm; V <sub>DD</sub> = 2.5V) ((MODE_CONTROL (0x41h) = 08h) (ALS_PS_CONTROL (0x42h): Gain = X1)	ALS <sub>IR_out</sub>	460	550	660	counts
ALS VIS sensor output at darkness ((MODE_CONTROL (0x41h) = 08h) (ALS_PS_CONTROL (0x42h): Gain = X1)	ALS <sub>VIS_out</sub>	0	0	2	counts
ALS IR sensor output at darkness ((MODE_CONTROL (0x41h) = 08h) (ALS_PS_CONTROL (0x42h): Gain = X1)	ALS <sub>IR_out</sub>	0	0	2	counts

Parameter	Symbol	Value			Unit
		min.	typ.	max.	
Resolution of the digital output signal based on gain settings for ALS VIS: MODE_CONTROL (0x41h) = 08h $t_{\text{int ALS}} = 100\text{ms}$ Gain X1 Gain X2 Gain X 64 Gain X 128  <i>High sensitive mode:</i> MODE_CONTROL (0x41h) = 0Ah $t_{\text{int ALS}} = 400\text{ms}$ Gain X 128 ( $V_{\text{DD}} = 2.5\text{V}$ ; white LED) - Gain settings at ALS_PS_CONTROL (0x42h)	ALS <sub>VIS_out</sub>		1.1 0.55 0.018 0.009       0.002		lx/count
Typical temperature coefficient for ALS measurement (1000lx; white LED; $V_{\text{DD}} = 2.5\text{V}$ )	$TC_{\text{Ev}}$		0.2		%/K
Mean current consumption ((MODE_CONTROL (0x41h) = 08h) (other registers are in default)	$I_{\text{DD}}$		90	150	$\mu\text{A}$
Typical error by Flicker noise (caused by bulbs (f=50 or 60Hz) or fluorescent lamps)				3	%

## Diagrams for ALS sensor

### Relative Spectral Sensitivity of ALS VIS

$$S_{\text{rel\_VIS}} = f(\lambda)$$

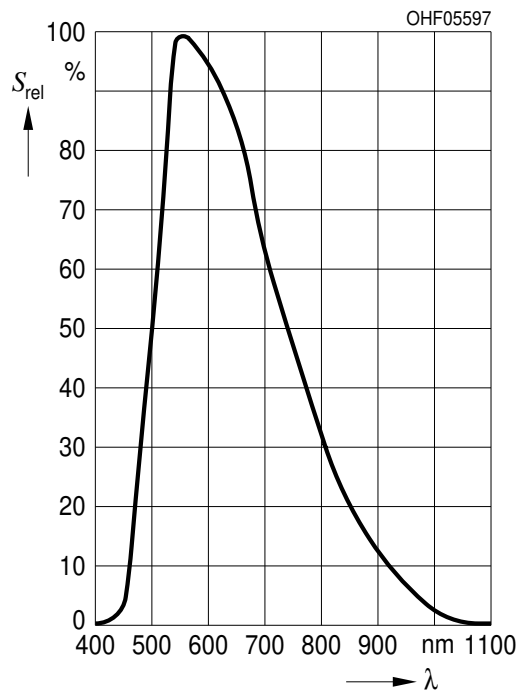

### Relative Spectral Sensitivity of ALS IR

$S_{\text{rel\_IR}} = f(\lambda)$ ; 100% = maximum sensitivity of ALS VIS diode

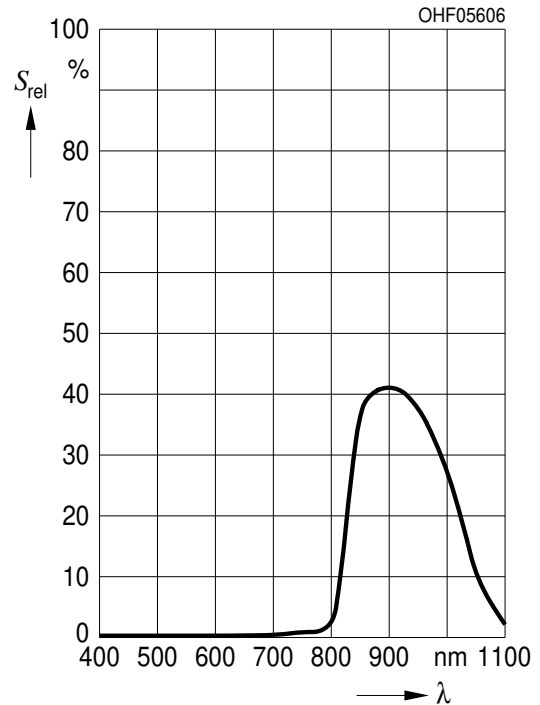

**ALS VIS sensitivity ranges**

ALS VIS output  $f(E_V)$ ; white LED;  $f$ (sensitivity settings);

$T_{int}$ : integration time (register 0x41h); X: gain settings (register 0x42h)

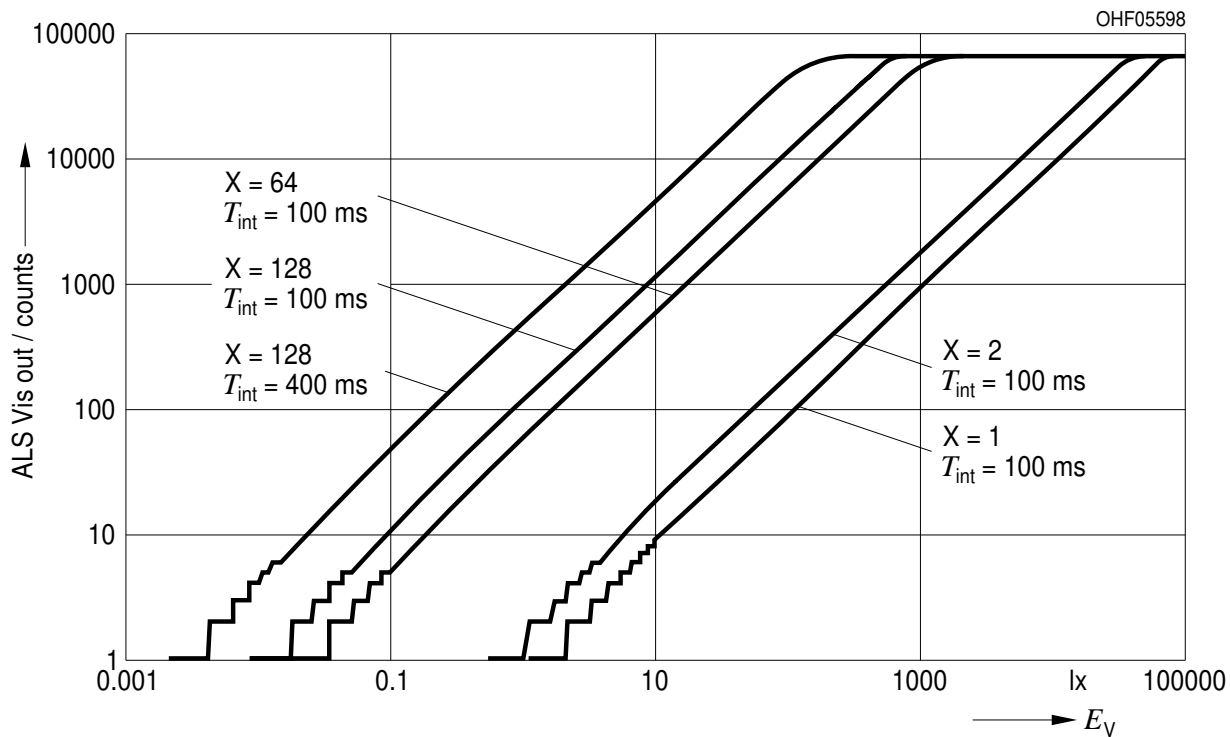

**Direction Characteristic of ALS Vis diode**

$S_{rel} f(\varphi)$

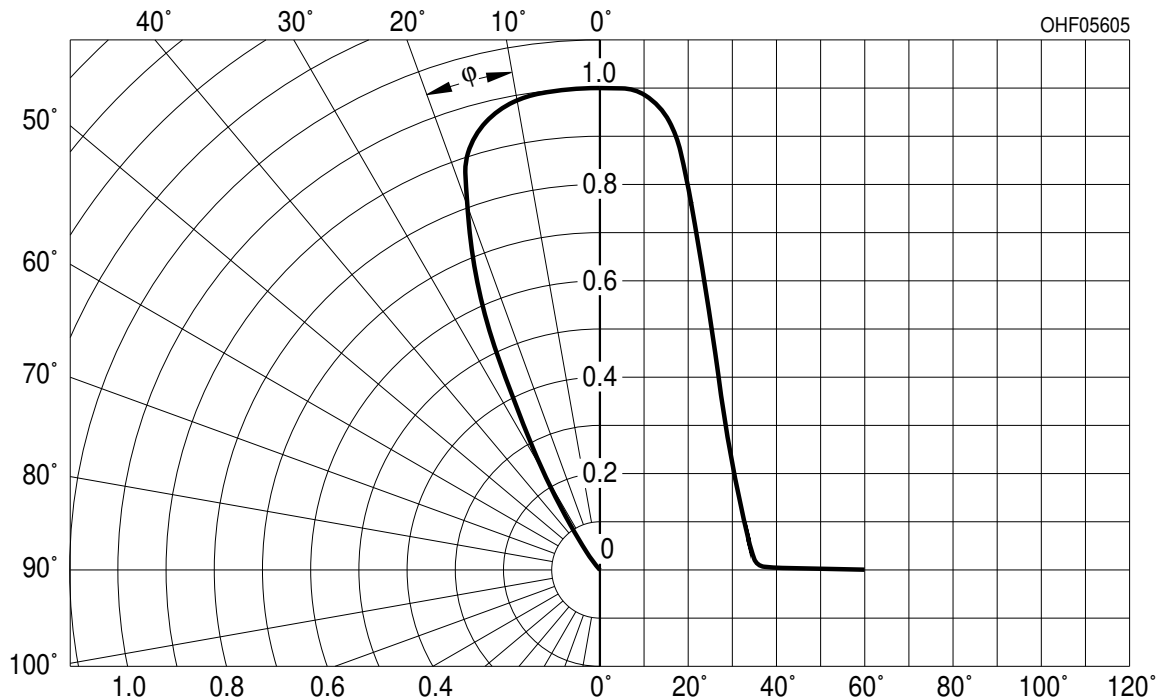



## Diagrams for PS sensor

### PS sensitivity f(R = reflectivity)

$V_{DD}=2.5V$ ;  $I_{LED}=200mA$ ;  $T_{rep}=100ms$ ;  $A_{Reflector} = 10 \times 13 \text{ cm}^2$

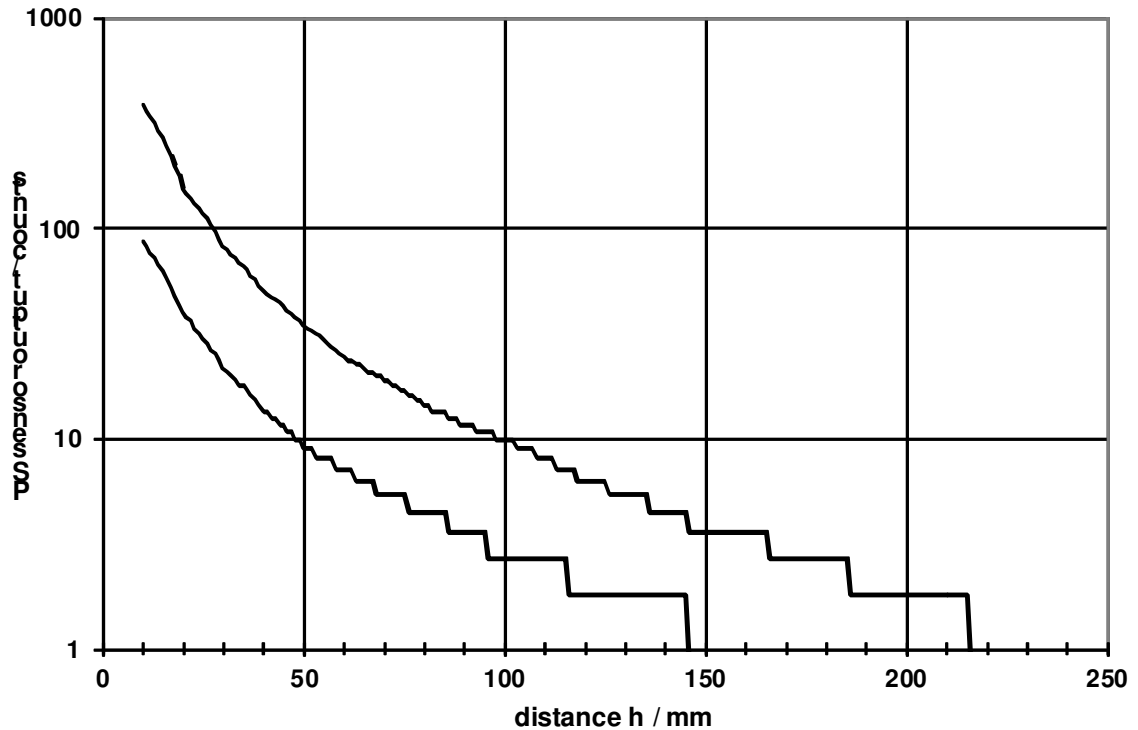

**PS sensitivity  $f(I_{LED})$**

$V_{DD}=2.5V$ ;  $T_{rep}=100ms$ ;  $R=90\%$ ;  $A_{Reflector} = 10 \times 13 \text{ cm}^2$

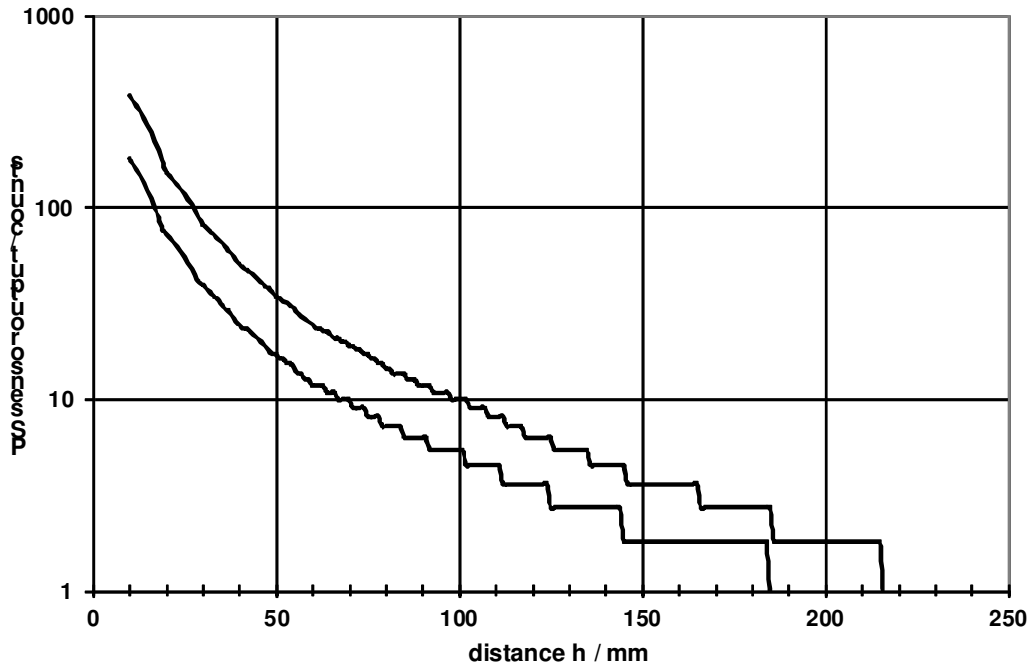

**Typical crosstalk free range**

$V_{DD}=2.5V$ ;  $I_{LED}=200mA$ ;  $T_{rep}=100ms$ ; glass without ink and one single IR transmissive opening ;

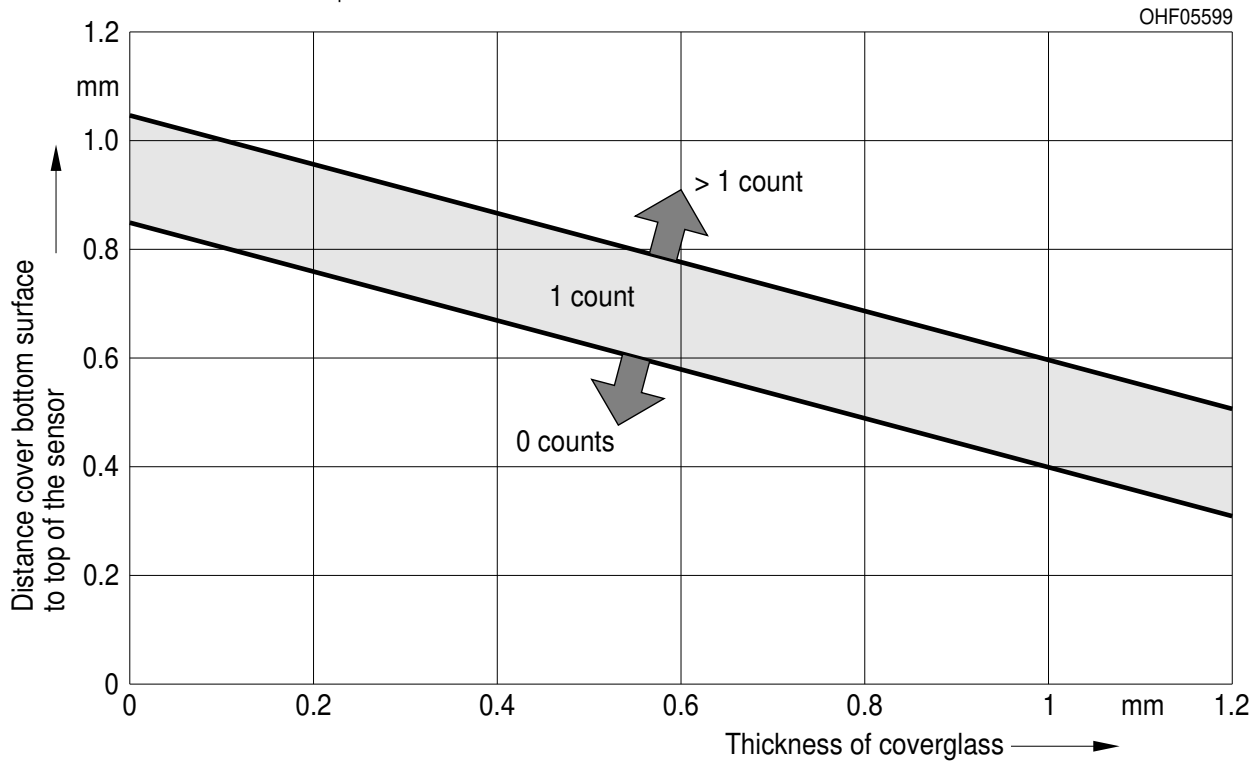

### Typical crosstalk free range

$V_{DD}=2.5V$ ;  $I_{LED}=200mA$ ;  $T_{rep}=100ms$ ; glass without ink and a two separate IR transmissive openings for emitter and detector

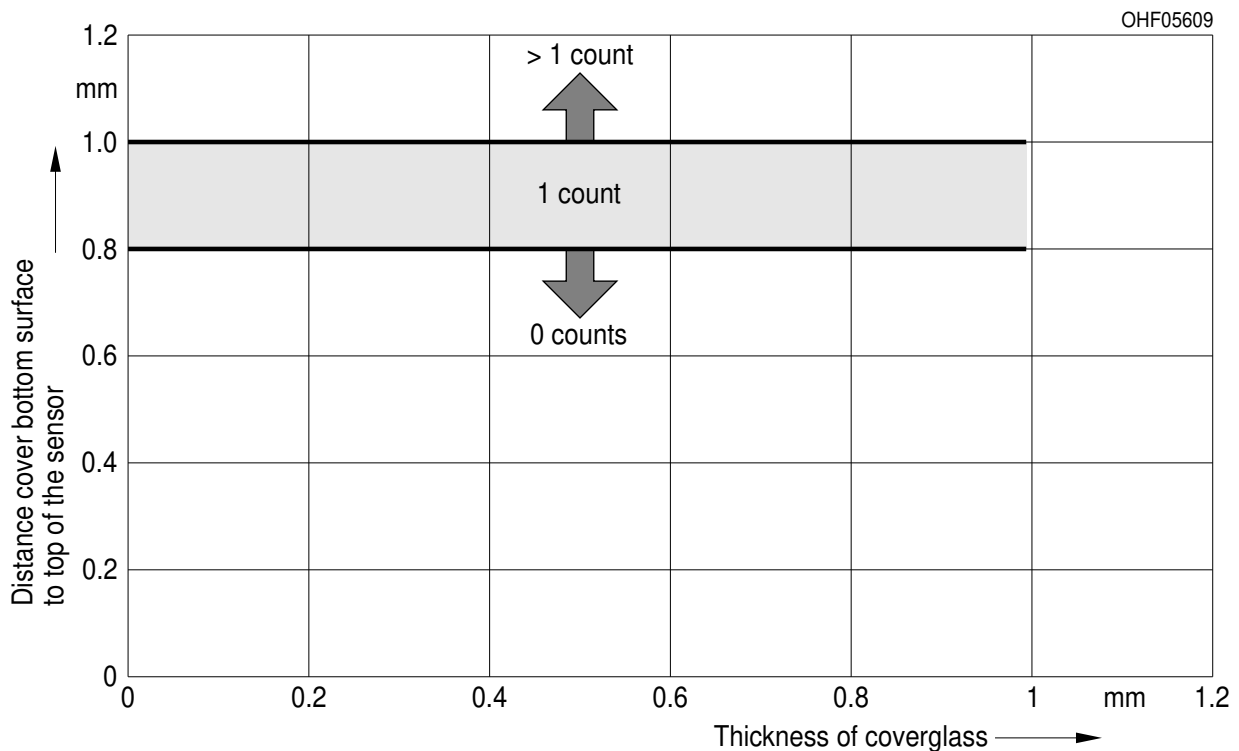

*Note for crosstalk free range: The displayed crosstalk free ranges for a single or two hole IR transmissive opening are measured with a clear cover. Depending on the used ink the crosstalk level can differ and needs to be measured. OSRAM OS provides customer related application support and measurements - please contact your OSRAM OS marketing or sales partner, if support is required.*

*As the measurement results show the typical performance of the sensor OSRAM OS recommends to design in an additional safety guard in the distance of the cover bottom surface to the top of the sensor of 200µm.*

*e.g.: for a 0.5mm thick cover window with two holes and an acceptable crosstalk level of 0 counts the distance of the cover window bottom surface to the top of the sensor should not exceed 0.6mm (typ. it would be 0.8mm)!*

Radiation Characteristics of the IR Emitter

$I_{rel} f(\varphi)$

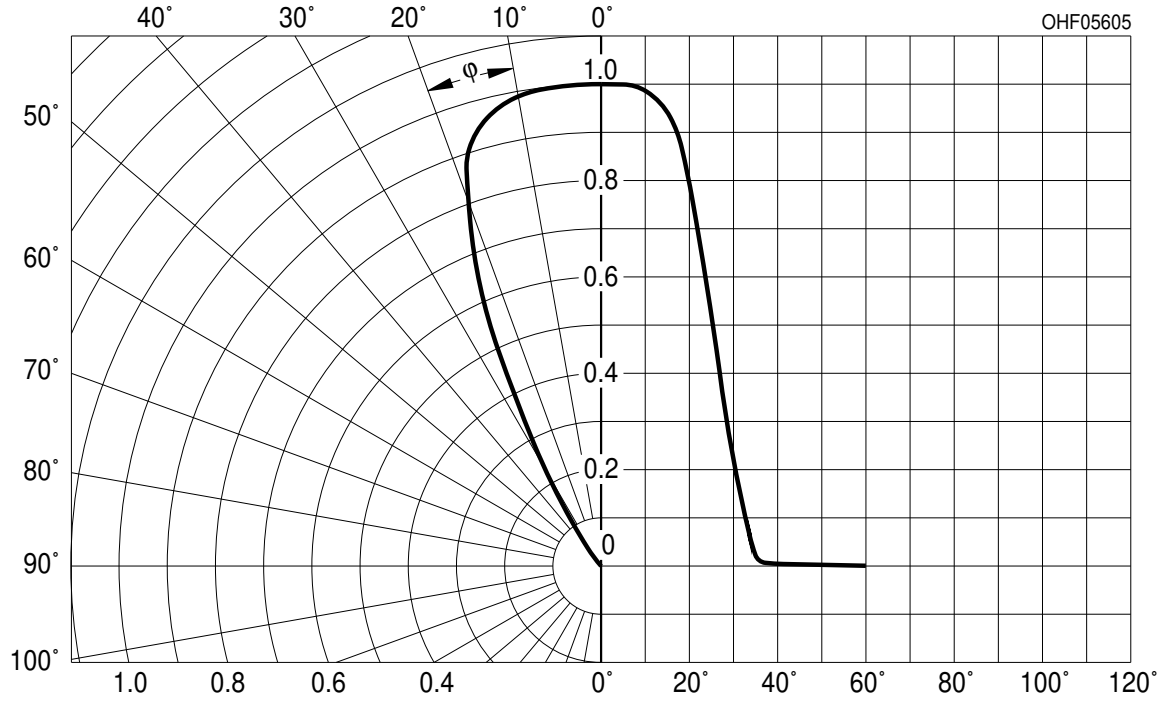

## Diagrams for $I_{DD}$ current consumption

### Current consumption $I_{DD}$ in standby mode

$I_{DD} = f(V_{DD})$ ; Register 0x41= 0x00

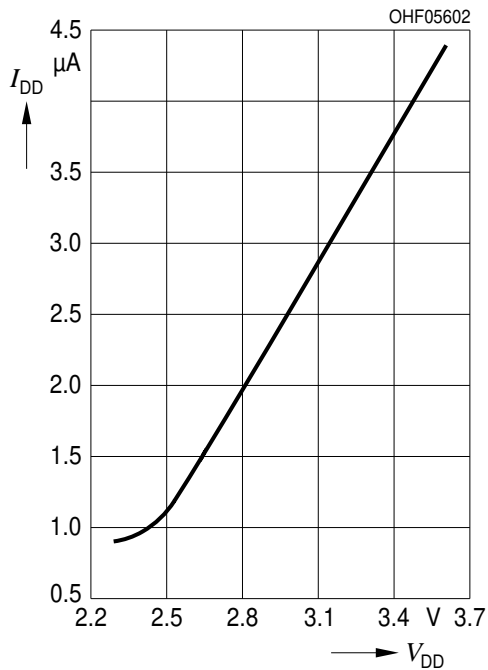

### Current consumption $I_{DD}$ in PS mode

$I_{DD} = f(V_{DD})$ ; Register 0x41= 0x03

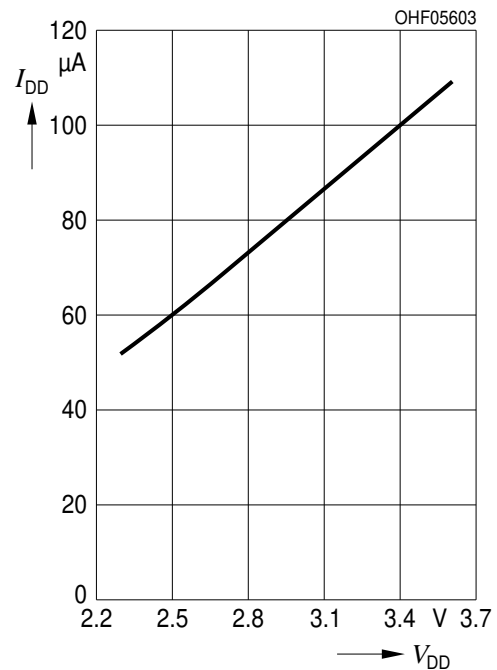

### Current consumption $I_{DD}$ in ALS mode

$I_{DD} = f(V_{DD})$ ; Register 0x41= 0x08

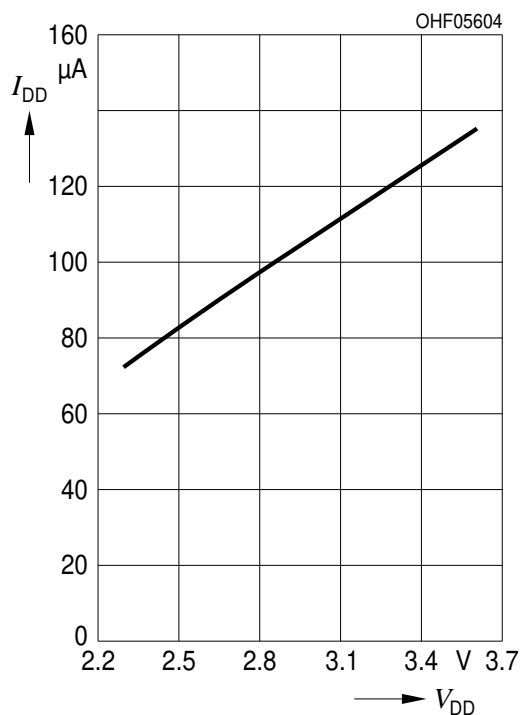

## Register

### SYSTEM\_CONTROL register (0x40h)

The SYSTEM\_CONTROL register is used to control the software (SW) reset and the interrupt function (INT). Manufacturer ID and Part ID can be read.

R/W-Register 0x40								
Bit	7	6	5	4	3	2	1	0
	<b>SW reset</b>	<b>INT reset</b>	<b>Manufacturer ID (Read only)</b>			<b>Part ID (Read only)</b>		
<b>default</b>	<b>0 Initial reset is not started</b>	<b>0 INT pin status is not initialized</b>	<b>001</b>			<b>001</b>		
	0 Initial reset is not started	0 INT pin status is not initialized						
	1 Initial reset started	1 INT pin become inactive (high impedance )						

### MODE\_CONTROL register (0x41h)

CONTROL of PS and ALS operating modes and time settings.

Repetition time is the time between two separate measurements. Integration time is the duration for one measurement. ALS high sensitivity modes are 1010 and 1011 with an increased integration time of 400ms. In PS operating mode: „normal mode“ only one PS measurement is performed during one PS repetition time. In PS operating mode „twice mode“ two independent PS measurement are performed within one PS repetition time. Both measurements are independent and can trigger the interrupt. This feature can be used to decrease the interrupt update time if the persistence function (register 0x43h) is used.



R/W-Register 0x41											
Bit	7	6	5	4		3	2	1	0	Repetition / Integration time	Repetition time
	Reserved		PS operating mode						ALS	PS	
default			0 normal mode				0000		standby	standby	
			0 normal mode				0000		standby	standby	
			1 twice mode				0001		standby	10ms	
							0010		standby	40ms	
							0011		standby	100ms	
							0100		standby	400ms	
							0101		100ms / 100ms	standby	
							0110		100ms / 100ms	100ms	
							0111		100ms / 100ms	400ms	
							1000		400ms / 100ms	standby	
							1001		400ms / 100ms	100ms	
							1010		400ms / <b>400ms</b>	standby	
							1011		400ms / <b>400ms</b>	400ms	
							1100		50ms / 50ms	50ms	
							Rest forbidden				

### ALS\_PS\_CONTROL register (0x42h)

ALS and PS Control of set the PS output mode, the ALS gain and the LED current. In the „Infrared DC level output“ PS mode (bit <6> = 1) the sensor measures the infrared DC ambient level. The proximity value of the reflected signal is not available in this mode.

R/W-Register 0x42											
Bit	7		6		5	4	3	2	1		0
	Reserved (read only)		PS output		ALS Gain for ALS VIS and ALS IR					LED current	
							ALS VIS	ALS PS			
default	write 0		0 proximity output		0000		X1	X1	11 200mA		

R/W-Register 0x42								
Bit	7	6	5	4	3	2	1	0
	Reserved (read only)	PS output	ALS Gain for ALS VIS and ALS IR				LED current	
		0 proximity output	0000	X1	X1		00 25 mA	
		1 Infrared DC level output	0100	X2	X1		01 50 mA	
			0101	X2	X2		10 100 mA	
			1010	X64	X64		11 200 mA	
			1110	X128	X64			
			1111	X128	X128			
			rest forbidden					

#### Persistence Register (0x43h)

Settings for the interrupt activation and of the persistence interrupt function. Persistence function is only valid for the PS measurements.

R/W-Register 0x43								
Bit	7	6	5	4	3	2	1	0
	Reserved (read only)				Persistence			
default	0000				0001 Interrupt status is updated after each measurement			

R/W-Register 0x43								
Bit	7	6	5	4	3	2	1	0
	Reserved (read only)				Persistence			
					0000 Interrupt becomes active after each measurement (The mode indicates that a PS or ALS measurement has been finished and can be read via the register. It is independent of the ALS & PS measurement value and threshold settings)			
					0001 Interrupt status is updated after each measurement (The interrupt status is updated independently after each measurement. <i>Active</i> or <i>Inactive</i> status of the interrupt is depending on the values of the last measurement in combination with the interrupt settings :“interrupt mode“ (register 0x4Ah) and „thresholds“ register 0c4Ch and following.)			
					0010 Interrupt status is updated if two consecutive threshold judgement are the same (The interrupt status only changes if the interrupt judgement of 2 consecutive measurement results are the same and different to the current interrupt status.)			
					0011 ... 1111 Interrupt status is updated if threshold judgement are the same over consecutive set times (3 .. 15) (This is the same procedure like in the 0010 persistence mode, but instead of 2 consecutive threshold judgments more are needed (3 to 15 depending on the setting) to change the interrupt status.) e.g.: 1010: 10 measurement results in a row need to fulfill the interrupt judgement to update the interrupt status			

**PS\_DATA\_LSBs register (0x44h)**

LSB of the PS output.

R-Register 0x44								
Bit	7	6	5	4	3	2	1	0
	$2^7$	$2^6$	$2^5$	$2^4$	$2^3$	$2^2$	$2^1$	$2^0$
default	0	0	0	0	0	0	0	0

**PS\_DATA\_MSBs register (0x45h)**

MSB of the PS output.

R-Register 0x45								
Bit	7	6	5	4	3	2	1	0
	not used	not used	not used	not used	$2^{11}$	$2^{10}$	$2^9$	$2^8$
default	0	0	0	0	0	0	0	0

**ALS\_VIS\_DATA\_LSBs register (0x46h)**

LSB of the ALS VIS output.

R-Register 0x46								
Bit	7	6	5	4	3	2	1	0
	$2^7$	$2^6$	$2^5$	$2^4$	$2^3$	$2^2$	$2^1$	$2^0$
default	0	0	0	0	0	0	0	0

**ALS\_VIS\_DATA\_MSBs register (0x47h)**

MSB of the ALS VIS output.

R-Register 0x47								
Bit	7	6	5	4	3	2	1	0
	$2^{15}$	$2^{14}$	$2^{13}$	$2^{12}$	$2^{11}$	$2^{10}$	$2^9$	$2^8$
default	0	0	0	0	0	0	0	0

**ALS\_IR\_DATA\_LSBs register (0x48h)**

LSB of the ALS IR output.

R-Register 0x48								
Bit	7	6	5	4	3	2	1	0
	$2^7$	$2^6$	$2^5$	$2^4$	$2^3$	$2^2$	$2^1$	$2^0$
default	0	0	0	0	0	0	0	0

**ALS\_IR\_DATA\_MSBs register (0x49h)**

MSB of the ALS IR output.

R-Register 0x49								
Bit	7	6	5	4	3	2	1	0
	$2^{15}$	$2^{14}$	$2^{13}$	$2^{12}$	$2^{11}$	$2^{10}$	$2^9$	$2^8$
default	0	0	0	0	0	0	0	0

**Interrupt function setting register (0x4Ah)**

Setting of the interrupt functions.

R/W-Register 0x4A								
Bit	7	6	5	4	3	2	1	0
	<b>PS INT status (read only)</b>	<b>ALS INT status (read only)</b>	<b>PS INT mode</b>		<b>INT assert</b>	<b>INT latch</b>	<b>INT trigger</b>	
<b>default</b>	0 inactive	0 inactive	00 PS_TH is only active		0 INT „L“ is stable	0 INT is latched	00 inactive	
	0 inactive	0 inactive	00 PS_TH (PS high threshold 0x4Bh & 0x4Ch) is only active		0 INT „L“ is stable if newer measurement results is also interrupt active	0 INT is latched until INT register is read or initialize	00 INT pin is inactive	
	1 active	1 active	01 PS_TH & PS_TL (PS high & low threshold) are active as hysteresis		1 INT „L“ is de-assert and re-assert if newer measurement results is also interrupt active	1 INT is updated after each measurement	01 triggered by PS only	
			10 PS_TH & PS_TL (PS high & low threshold) are active as outside detection				10 triggered by ALS only	
			11 forbidden				11 triggered by PS or ALS	

**PS INT** and **ALS INT** status (bit <7;6>): Directly after reading the register the interrupt status for PS and ALS and the INT Pin of the sensor is automatically set back to inactive status independent on the measurement results.

**PS INT mode** (bit <5;4>): The INT modes are only valid for the PS interrupt function. For description please see extra chapter „**PS INT Modes**“ (at the end of the register chapter).

**INT assert** (bit <3>): Is used to adjust the sensor behaviour to the used micro controller trigger settings. In case a repeated trigger in low state is needed the **INT assert** can be set to 1.

**INT trigger** (bit <2>): defines the source / sources for the interrupt.

**INT latched** (bit <1>): In latched mode the interrupt status stays active after the first activation. It is only released by reading the status are performing an interrupt reset.

**PS\_TH\_LSBs register (0x4Bh)**

LSB for the PS threshold „HIGH“.

R/W-Register 0x4B								
Bit	7	6	5	4	3	2	1	0
	$2^7$	$2^6$	$2^5$	$2^4$	$2^3$	$2^2$	$2^1$	$2^0$
<b>default</b>	1	1	1	1	1	1	1	1

**PS\_TH\_MSBs register (0x4Ch)**

MSB for the PS threshold „HIGH“.

R/W-Register 0x4C								
Bit	7	6	5	4	3	2	1	0
					$2^{11}$	$2^{10}$	$2^9$	$2^8$
default	0	0	0	0	1	1	1	1

**PS\_TL\_LSBs register (0x4Dh)**

LSB for the PS threshold „LOW“.

R/W-Register 0x4D								
Bit	7	6	5	4	3	2	1	0
	$2^7$	$2^6$	$2^5$	$2^4$	$2^3$	$2^2$	$2^1$	$2^0$
default	0	0	0	0	0	0	0	0

**PS\_TL\_MSBs register (0x4Eh)**

MSB for the PS threshold „LOW“.

R/W-Register 0x4E								
Bit	7	6	5	4	3	2	1	0
					$2^{11}$	$2^{10}$	$2^9$	$2^8$
default	0	0	0	0	0	0	0	0

**ALS\_VIS\_TH\_LSBs register (0x4Fh)**

LSB for the ALS VIS threshold „HIGH“.

R/W-Register 0x4F								
Bit	7	6	5	4	3	2	1	0
	$2^7$	$2^6$	$2^5$	$2^4$	$2^3$	$2^2$	$2^1$	$2^0$
default	1	1	1	1	1	1	1	1

**ALS\_VIS\_TH\_MSBs register (0x50h)**

MSB for the ALS VIS threshold „HIGH“.

R/W-Register 0x50								
Bit	7	6	5	4	3	2	1	0
	$2^{15}$	$2^{14}$	$2^{13}$	$2^{12}$	$2^{11}$	$2^{10}$	$2^9$	$2^8$
default	1	1	1	1	1	1	1	1