



Chipsmall Limited consists of a professional team with an average of over 10 year of expertise in the distribution of electronic components. Based in Hongkong, we have already established firm and mutual-benefit business relationships with customers from,Europe,America and south Asia,supplying obsolete and hard-to-find components to meet their specific needs.

With the principle of “Quality Parts,Customers Priority,Honest Operation,and Considerate Service”,our business mainly focus on the distribution of electronic components. Line cards we deal with include Microchip,ALPS,ROHM,Xilinx,Pulse,ON,Everlight and Freescale. Main products comprise IC,Modules,Potentiometer,IC Socket,Relay,Connector.Our parts cover such applications as commercial,industrial, and automotives areas.

We are looking forward to setting up business relationship with you and hope to provide you with the best service and solution. Let us make a better world for our industry!



Contact us

Tel: +86-755-8981 8866 Fax: +86-755-8427 6832

Email & Skype: info@chipsmall.com Web: www.chipsmall.com

Address: A1208, Overseas Decoration Building, #122 Zhenhua RD., Futian, Shenzhen, China



Optocoupler, Photodarlington Output, SOP-4 Mini-Flat Package

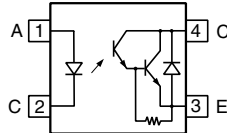
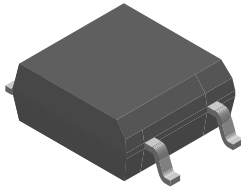

1179067

DESCRIPTION

The SFH692AT has a GaAs infrared emitting diode emitter, which is optically coupled to silicon planar photodarlington detector, and is incorporated in a 4 pin 100 mil lead pitch miniflat package. It features a high current transfer ratio, low coupling capacitance, and high isolation voltage. The coupling devices are designed for signal transmission between two electrically separated circuits. The SFH692AT is available only on tape and reel.

FEATURES

- SOP (small outline package)
- Isolation test voltage, 3750 V_{RMS} (1.0 s)
- High collector emitter breakdown voltage, V_{CEO} = 300 V
- Low saturation voltage
- Fast switching times
- Temperature stable
- Low coupling capacitance
- End stackable, 0.100" (2.54 mm) spacing
- Lead (Pb)-free component
- Component in accordance to RoHS 2002/95/EC and WEEE 2002/96/EC

RoHS
COMPLIANT

APPLICATIONS

- High density mounting or space sensitive PCBs
- PLCs
- Telecommunication

AGENCY APPROVALS

- UL1577, file no. E52744 system code U
- DIN EN 60747-5-5 available with option 1
- FIMKO

ORDER INFORMATION

PART	REMARKS
SFH692AT	CTR > 1000 %, SMD-4

ABSOLUTE MAXIMUM RATINGS (1)

PARAMETER	TEST CONDITION	SYMBOL	VALUE	UNIT
INPUT				
DC forward current		I _F	50	mA
Reverse voltage		V _R	6.0	V
Surge forward current	t _p ≤ 10 μs	I _{FSM}	2.5	A
Total power dissipation		P _{diss}	80	mW
OUTPUT				
Collector emitter voltage		V _{CE}	300	V
Emitter collector voltage		V _{EC}	0.3	V
Collector current		I _C	50	mA
	t _p = 1.0 ms	I _C	150	mA
Total power dissipation		P _{diss}	200	mW
COUPLER				
Isolation test voltage between emitter and detector	1.0 s	V _{ISO}	3750	V _{RMS}
Isolation resistance	V _{IO} = 500 V, T _{amb} = 25 °C	R _{IO}	≥ 10 ¹²	Ω
	V _{IO} = 500 V, T _{amb} = 100 °C	R _{IO}	≥ 10 ¹¹	Ω

ABSOLUTE MAXIMUM RATINGS (1)				
PARAMETER	TEST CONDITION	SYMBOL	VALUE	UNIT
COUPLER				
Storage temperature range		T_{stg}	- 55 to + 150	°C
Ambient temperature range		T_{amb}	- 55 to + 100	°C
Junction temperature		T_j	100	°C
Soldering temperature (2)	max. 10 s dip soldering distance to seating plane \geq 1.5 mm	T_{sld}	260	°C

Notes

(1) $T_{amb} = 25$ °C, unless otherwise specified.

Stresses in excess of the absolute maximum ratings can cause permanent damage to the device. Functional operation of the device is not implied at these or any other conditions in excess of those given in the operational sections of this document. Exposure to absolute maximum ratings for extended periods of the time can adversely affect reliability.

(2) Refer to reflow profile for soldering conditions for surface mounted devices.

ELECTRICAL CHARACTERISTICS						
PARAMETER	TEST CONDITION	SYMBOL	MIN.	TYP.	MAX.	UNIT
INPUT						
Forward voltage	$I_F = 10$ mA	V_F		1.2	1.5	V
Reverse current	$V_R = 6.0$ V	I_R		0.01	10	μ A
Capacitance	$V_R = 0$ V, $f = 1.0$ MHz	C_O		14		pF
Thermal resistance		R_{thja}		750		K/W
OUTPUT						
Collector emitter leakage current	$V_{CE} = 200$ V	I_{CEO}			200	nA
Collector emitter capacitance	$V_{CE} = 5.0$ V, $f = 1.0$ MHz	C_{CE}		39		pF
Thermal resistance		R_{thja}		500		K/W
COUPLER						
Collector emitter saturation voltage	$I_F = 1.0$ mA, $I_C = 10$ mA	V_{CEsat}			1.0	V
	$I_F = 10$ mA, $I_C = 100$ mA	V_{CEsat}	0.3		1.2	V
Coupling capacitance	$f = 1.0$ MHz, $V_{I-O} = 0$ V	C_C		6.0		pF

Note

$T_{amb} = 25$ °C, unless otherwise specified.

Minimum and maximum values are testing requirements. Typical values are characteristics of the device and are the result of engineering evaluation. Typical values are for information only and are not part of the testing requirements.

CURRENT TRANSFER RATIO						
PARAMETER	TEST CONDITION	SYMBOL	MIN.	TYP.	MAX.	UNIT
Current transfer ratio	$I_F = 1.0$ mA, $V_{CE} = 1.0$ V	CTR	1000			%
Current transfer ratio (collector emitter saturated)	$I_F = 10$ mA, $V_{CE} = 1.0$ V	CTR_{CEsat}	500			%

SWITCHING CHARACTERISTICS						
PARAMETER	TEST CONDITION	SYMBOL	MIN.	TYP.	MAX.	UNIT
Rise time	$I_C = 10$ mA, $V_{CC} = 10$ V, $R_L = 100$ Ω	t_r			3.5	μ s
	$I_C = 16$ mA, $V_{CC} = 10$ V, $R_L = 180$ Ω	t_r		1.0		μ s
Fall time	$I_C = 10$ mA, $V_{CC} = 10$ V, $R_L = 100$ Ω	t_f			14.5	μ s
	$I_C = 16$ mA, $V_{CC} = 10$ V, $R_L = 180$ Ω	t_f		20.5		μ s
Turn-on time	$I_C = 10$ mA, $V_{CC} = 10$ V, $R_L = 100$ Ω	t_{on}			4.5	μ s
	$I_C = 16$ mA, $V_{CC} = 10$ V, $R_L = 180$ Ω	t_{on}		1.5		μ s
Turn-off time	$I_C = 10$ mA, $V_{CC} = 10$ V, $R_L = 100$ Ω	t_{off}			29	μ s
	$I_C = 16$ mA, $V_{CC} = 10$ V, $R_L = 180$ Ω	t_{off}		53.5		μ s

SAFETY AND INSULATION RATINGS						
PARAMETER	TEST CONDITION	SYMBOL	MIN.	TYP.	MAX.	UNIT
Climatic classification (according to IEC 68 part 1)				55/100/21		
Comparative tracking index		CTI	175		399	
V_{IOTM}			6000			V
V_{IORM}			707			V
P_{SO}					350	mW
I_{SI}					150	mA
T_{SI}					175	°C
Creepage distance			5			mm
Clearance distance			5			mm
Insulation thickness			0.4			mm

Note

As per IEC 60747-5-2, § 7.4.3.8.1, this optocoupler is suitable for "safe electrical insulation" only within the safety ratings. Compliance with the safety ratings shall be ensured by means of protective circuits.

TYPICAL CHARACTERISTICS

$T_{amb} = 25\text{ }^{\circ}\text{C}$, unless otherwise specified

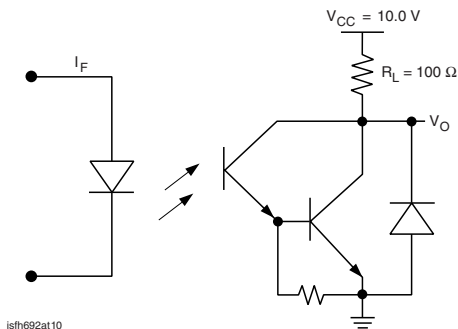

isth692at10

Fig. 1 - Linear Operation (without Saturation)

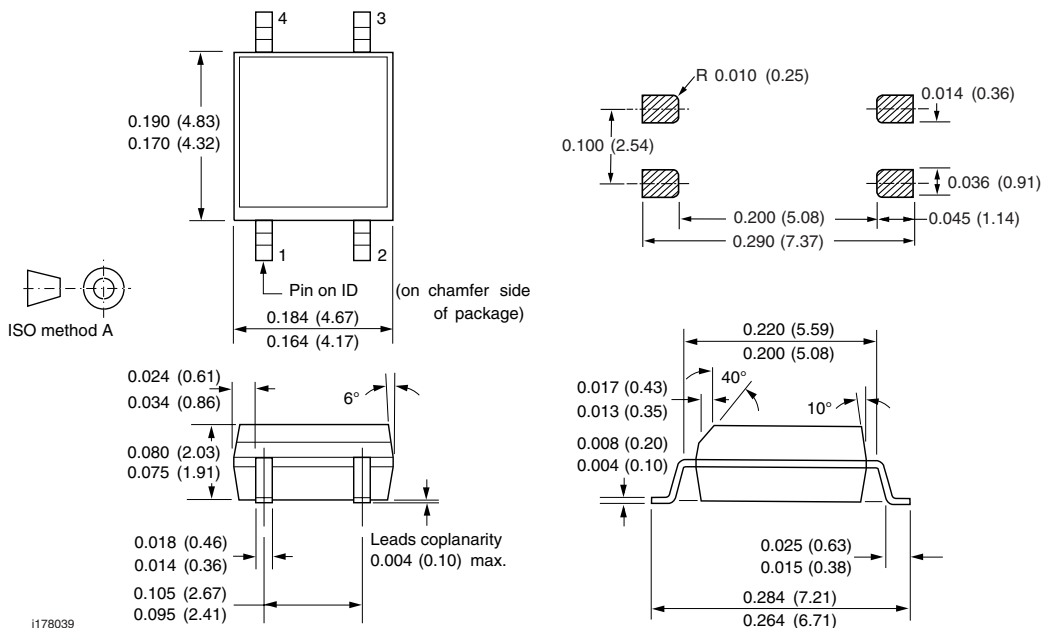
PACKAGE DIMENSIONS in inches (millimeters)

i178039

OZONE DEPLETING SUBSTANCES POLICY STATEMENT

It is the policy of Vishay Semiconductor GmbH to

1. Meet all present and future national and international statutory requirements.
2. Regularly and continuously improve the performance of our products, processes, distribution and operating systems with respect to their impact on the health and safety of our employees and the public, as well as their impact on the environment.

It is particular concern to control or eliminate releases of those substances into the atmosphere which are known as ozone depleting substances (ODSs).

The Montreal Protocol (1987) and its London Amendments (1990) intend to severely restrict the use of ODSs and forbid their use within the next ten years. Various national and international initiatives are pressing for an earlier ban on these substances.

Vishay Semiconductor GmbH has been able to use its policy of continuous improvements to eliminate the use of ODSs listed in the following documents.

1. Annex A, B and list of transitional substances of the Montreal Protocol and the London Amendments respectively.
2. Class I and II ozone depleting substances in the Clean Air Act Amendments of 1990 by the Environmental Protection Agency (EPA) in the USA.
3. Council Decision 88/540/EEC and 91/690/EEC Annex A, B and C (transitional substances) respectively.

Vishay Semiconductor GmbH can certify that our semiconductors are not manufactured with ozone depleting substances and do not contain such substances.

We reserve the right to make changes to improve technical design
and may do so without further notice.

Parameters can vary in different applications. All operating parameters must be validated for each customer application by the customer. Should the buyer use Vishay Semiconductors products for any unintended or unauthorized application, the buyer shall indemnify Vishay Semiconductors against all claims, costs, damages, and expenses, arising out of, directly or indirectly, any claim of personal damage, injury or death associated with such unintended or unauthorized use.

Vishay Semiconductor GmbH, P.O.B. 3535, D-74025 Heilbronn, Germany



Disclaimer

All product specifications and data are subject to change without notice.

Vishay Intertechnology, Inc., its affiliates, agents, and employees, and all persons acting on its or their behalf (collectively, "Vishay"), disclaim any and all liability for any errors, inaccuracies or incompleteness contained herein or in any other disclosure relating to any product.

Vishay disclaims any and all liability arising out of the use or application of any product described herein or of any information provided herein to the maximum extent permitted by law. The product specifications do not expand or otherwise modify Vishay's terms and conditions of purchase, including but not limited to the warranty expressed therein, which apply to these products.

No license, express or implied, by estoppel or otherwise, to any intellectual property rights is granted by this document or by any conduct of Vishay.

The products shown herein are not designed for use in medical, life-saving, or life-sustaining applications unless otherwise expressly indicated. Customers using or selling Vishay products not expressly indicated for use in such applications do so entirely at their own risk and agree to fully indemnify Vishay for any damages arising or resulting from such use or sale. Please contact authorized Vishay personnel to obtain written terms and conditions regarding products designed for such applications.

Product names and markings noted herein may be trademarks of their respective owners.