



Chipsmall Limited consists of a professional team with an average of over 10 year of expertise in the distribution of electronic components. Based in Hongkong, we have already established firm and mutual-benefit business relationships with customers from,Europe,America and south Asia,supplying obsolete and hard-to-find components to meet their specific needs.

With the principle of “Quality Parts,Customers Priority,Honest Operation,and Considerate Service”,our business mainly focus on the distribution of electronic components. Line cards we deal with include Microchip,ALPS,ROHM,Xilinx,Pulse,ON,Everlight and Freescale. Main products comprise IC,Modules,Potentiometer,IC Socket,Relay,Connector.Our parts cover such applications as commercial,industrial, and automotives areas.

We are looking forward to setting up business relationship with you and hope to provide you with the best service and solution. Let us make a better world for our industry!



## Contact us

Tel: +86-755-8981 8866 Fax: +86-755-8427 6832

Email & Skype: info@chipsmall.com Web: www.chipsmall.com

Address: A1208, Overseas Decoration Building, #122 Zhenhua RD., Futian, Shenzhen, China





RFMD Green, RoHS Compliant, Pb-Free (Z Part Number)  
Package: SOT-363

**Product Description**

The SGA-0363 is a high performance SiGe HBT MMIC Amplifier. A Darlington configuration featuring one-micron emitters provides high FT and excellent thermal performance. The heterojunction increases breakdown voltage and minimizes leakage current between junctions. Cancellation of emitter junction non-linearities results in higher suppression of intermodulation products. Only two DC-blocking capacitors, a bias resistor and an optional RF choke are required for operation.

**Features**

- DC to 5000MHz Operation
- Single Voltage Supply
- Low Current Draw: 11mA at 2.5V Typ.
- High Output Intercept: 14dBm Typ. at 1950MHz

**Applications**

- PA Driver Amplifier
- Cellular, PCS, GSM, UMTS
- IF Amplifier
- Wireless Data, Satellite

**Optimum Technology Matching® Applied**

- GaAs HBT
- GaAs MESFET
- InGaP HBT
- SiGe BiCMOS
- Si BiCMOS
- SiGe HBT
- GaAs pHEMT
- Si CMOS
- Si BJT
- GaN HEMT
- RF MEMS

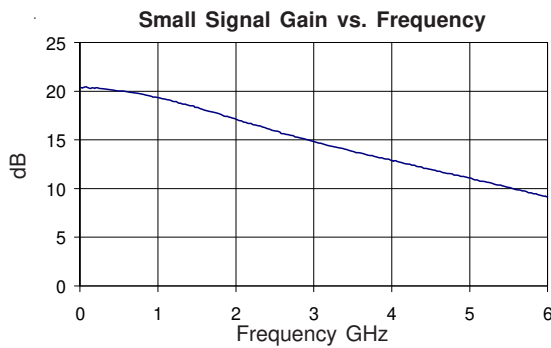

Parameter	Specification			Unit	Condition
	Min.	Typ.	Max.		
Output Power at 1dB Compression		2.3		dBm	850MHz
		2.3		dBm	1950MHz
		1.6		dBm	2400MHz
Third Order Intercept Point		14.2		dBm	850MHz
		14.0		dBm	1950MHz
		13.1		dBm	2400MHz
Small Signal Gain		19.6		dB	850MHz
		17.2		dB	1950MHz
		16.2		dB	2400MHz
3dB Bandwidth		5000		MHz	
Input VSWR		1.8:1			DC to 4500MHz
Output VSWR		1.7:1			DC to 4500MHz
Reverse Isolation		24.0		dB	850MHz
		22.8		dB	1950MHz
		22.1		dB	2400MHz
Noise Figure <sup>[1]</sup>		3.0		dB	1950MHz
Device Operating Voltage		2.5		V	
Device Operating Current	9	11	13	mA	
Thermal Resistance		255		°C/W	junction - lead

Test Conditions: V<sub>S</sub>=5V, I<sub>D</sub>=11mA Typ., T<sub>L</sub>=25°C. OIP3 Tone Spacing=1MHz, P<sub>OUT</sub> per tone=-12dBm, R<sub>BIAS</sub>=220Ω, Z<sub>S</sub>=Z<sub>L</sub>=50Ω

RF MICRO DEVICES®, RFMD®, Optimum Technology Matching®, Enabling Wireless Connectivity™, PowerStar®, POLARIS™ TOTAL RADIO™ and UltimateBlue™ are trademarks of RFMD, LLC. BLUETOOTH is a trademark owned by Bluetooth SIG, Inc., U.S.A. and licensed for use by RFMD. All other trade names, trademarks and registered trademarks are the property of their respective owners. ©2006, RF Micro Devices, Inc.

## Absolute Maximum Ratings

Parameter	Rating	Unit
Device Current (I <sub>D</sub> )	22	mA
Device Voltage (V <sub>D</sub> )	6	V
RF Input Power	-5	dBm
Junction Temp (T <sub>J</sub> )	+150	°C
Operating Temp Range (T <sub>L</sub> )	-40 to +85	°C
Storage Temp	+150	°C



Caution! ESD sensitive device.

Exceeding any one or a combination of the Absolute Maximum Rating conditions may cause permanent damage to the device. Extended application of Absolute Maximum Rating conditions to the device may reduce device reliability. Specified typical performance or functional operation of the device under Absolute Maximum Rating conditions is not implied.

RoHS status based on EU Directive 2002/95/EC (at time of this document revision).

The information in this publication is believed to be accurate and reliable. However, no responsibility is assumed by RF Micro Devices, Inc. ("RFMD") for its use, nor for any infringement of patents, or other rights of third parties, resulting from its use. No license is granted by implication or otherwise under any patent or patent rights of RFMD. RFMD reserves the right to change component circuitry, recommended application circuitry and specifications at any time without prior notice.

Operation of this device beyond any one of these limits may cause permanent damage. For reliable continuous operation, the device voltage and current must not exceed the maximum operating values specified in the table on page one.

Bias Conditions should also satisfy the following expression:

$$I_D V_D < (T_J - T_L) / R_{TH, j-l}$$

Parameter	Specification			Unit	Condition
	Min.	Typ.	Max.		
Gain		20.4		dB	100MHz
		20.0		dB	500MHz
		19.6		dB	850MHz
		17.2		dB	1950MHz
		16.2		dB	2400MHz
Output IP <sub>3</sub>		13.8		dB	3500MHz
		14.8		dBm	100MHz, Tone spacing=1MHz, P <sub>OUT</sub> per tone=-12dBm
		14.5		dBm	500MHz, Tone spacing=1MHz, P <sub>OUT</sub> per tone=-12dBm
		14.2		dBm	850MHz, Tone spacing=1MHz, P <sub>OUT</sub> per tone=-12dBm
		14.0		dBm	1950MHz, Tone spacing=1MHz, P <sub>OUT</sub> per tone=-12dBm
Output P1dB		13.1		dBm	2400MHz, Tone spacing=1MHz, P <sub>OUT</sub> per tone=-12dBm
		11.5		dBm	3500MHz, Tone spacing=1MHz, P <sub>OUT</sub> per tone=-12dBm
		3.2		dBm	100MHz
		2.9		dBm	500MHz
		2.3		dBm	850MHz
Input Return Loss		2.3		dBm	1950MHz
		1.6		dBm	2400MHz
		0.8		dBm	3500MHz
		9.3		dB	100MHz
		9.4		dB	500MHz
Reverse Isolation		9.4		dB	850MHz
		10.4		dB	1950MHz
		10.8		dB	2400MHz
		11.3		dB	3500MHz
		23.9		dB	100MHz
Noise Figure		23.9		dB	500MHz
		24.0		dB	850MHz
		22.8		dB	1950MHz
		22.1		dB	2400MHz
		20.1		dB	3500MHz
Noise Figure		2.9		dB	100MHz, Z <sub>S</sub> =50Ω
		2.8		dB	500MHz, Z <sub>S</sub> =50Ω
		3.0		dB	850MHz, Z <sub>S</sub> =50Ω
		3.0		dB	1950MHz, Z <sub>S</sub> =50Ω

Test Conditions: I<sub>D</sub>=8mA, unless otherwise noted

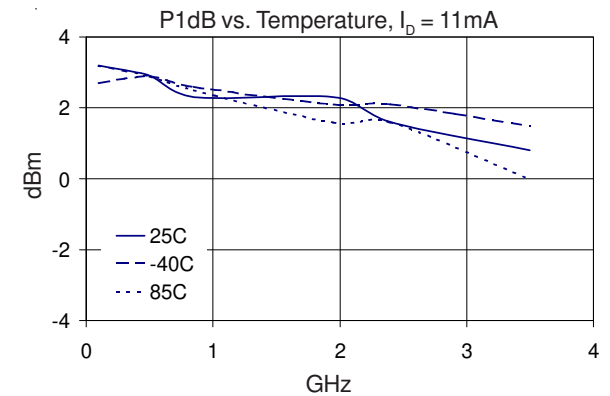
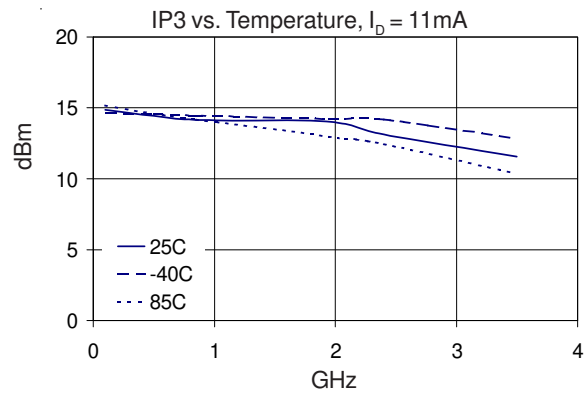
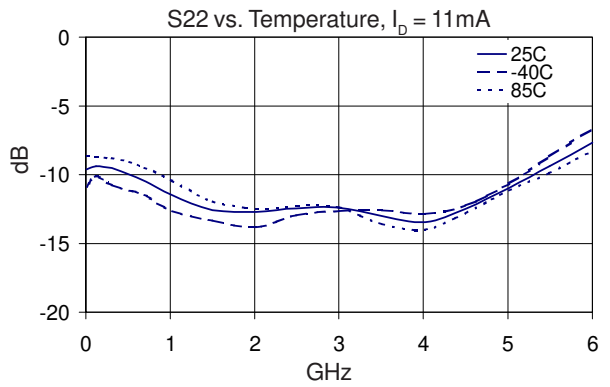
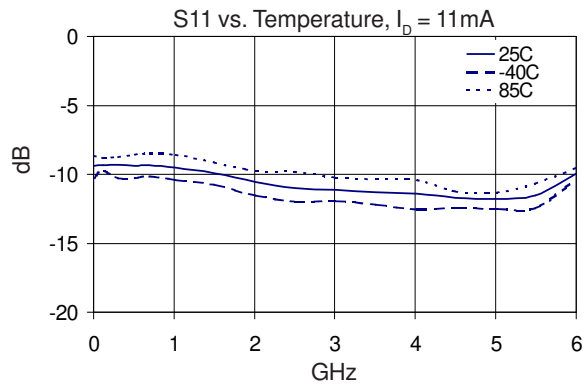
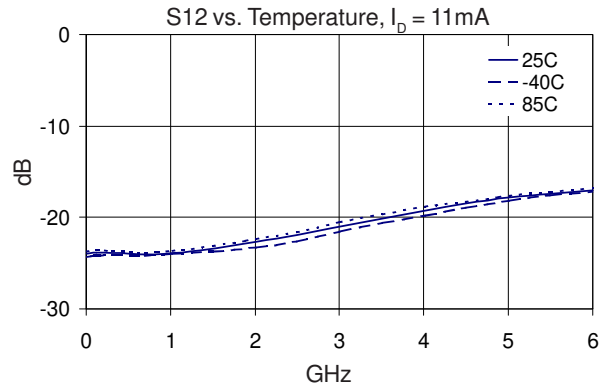
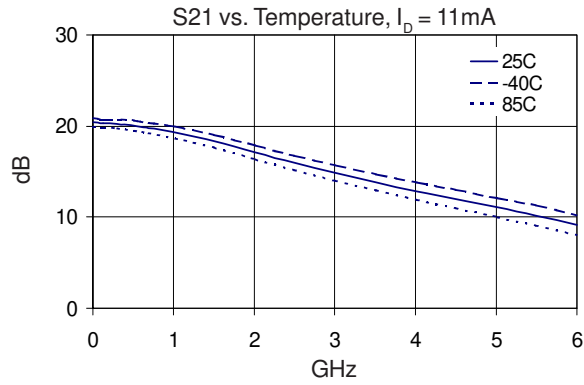

Pin	Function	Description
3	RF IN	RF input pin. This pin requires the use of an external DC blocking capacitor chosen for the frequency of operation.
1, 2, 4, 5	GND	Connection to ground. Use via holes for best performance to reduce lead inductance as close to ground leads as possible.
6	RF OUT/BIAS	RF output and bias pin. DC voltage is present on this pin, therefore a DC blocking capacitor is necessary for proper operation.

## Suggested Pad Layout

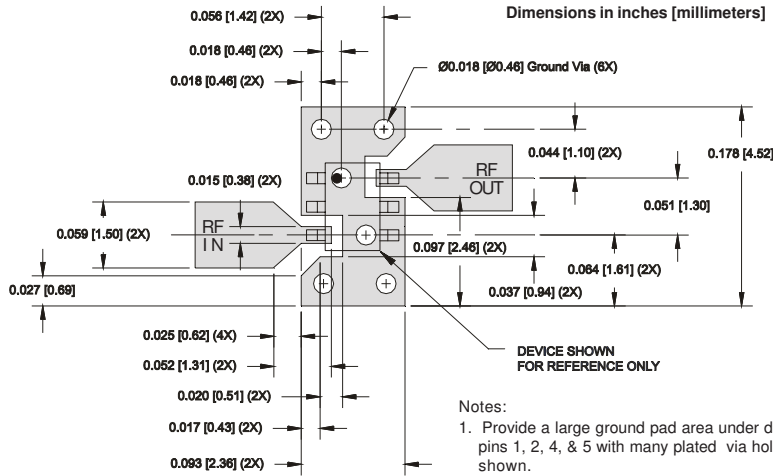

- Notes:
1. Provide a large ground pad area under device pins 1, 2, 4, & 5 with many plated via holes as shown.
  2. Dimensions given for 50 Ohm RF I/O lines are for 31 mil thick Getek. Scale accordingly for different board thicknesses and dielectric constants.
  3. We recommend 1 or 2 ounce copper. Measurements for this data sheet were made on a 31 mil thick Getek with 1 ounce copper on both sides.

## Package Drawing

Dimensions in inches (millimeters)  
 Refer to drawing posted at [www.rfmd.com](http://www.rfmd.com) for tolerances.

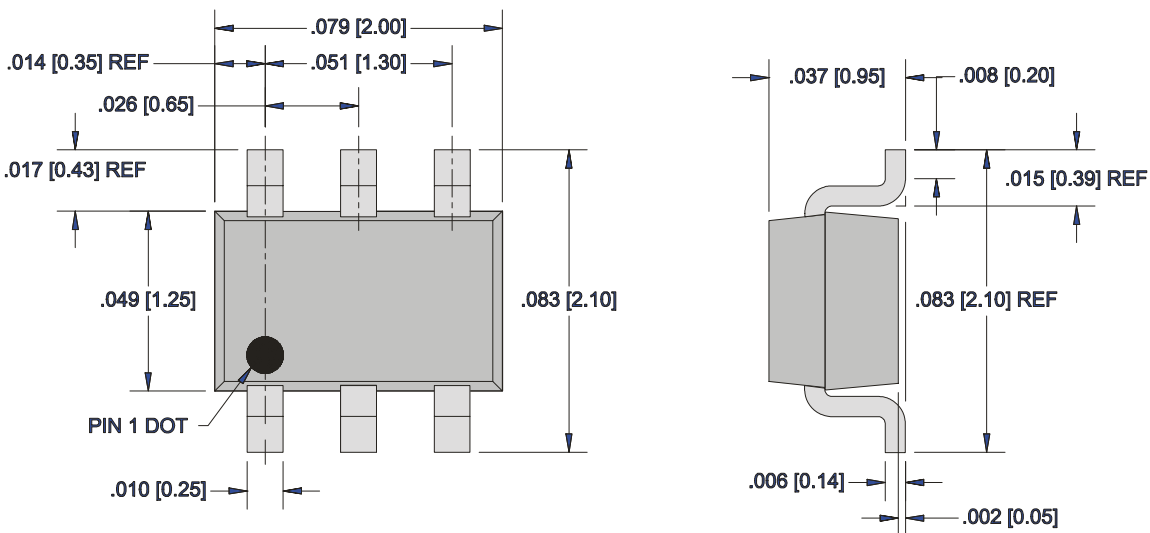

**Application Schematic**

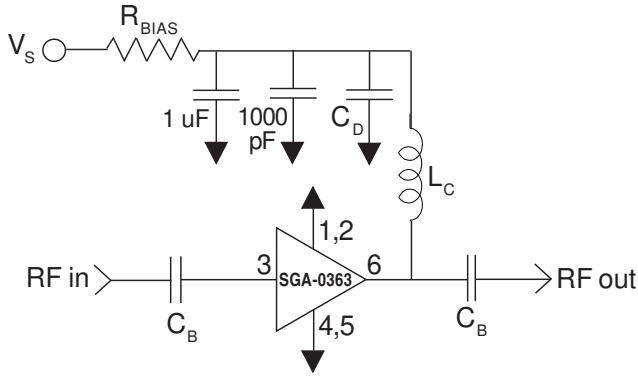

Reference Designator	Frequency (Mhz)				
	500	850	1950	2400	3500
C <sub>b</sub>	220 pF	100 pF	68 pF	56 pF	39 pF
C <sub>d</sub>	100 pF	68 pF	22 pF	22 pF	15 pF
L <sub>c</sub>	68 nH	33 nH	22 nH	18 nH	15 nH

Recommended Bias Resistor Values for I <sub>D</sub> =11mA					
$R_{BIAS} = (V_S - V_D) / I_D$					
Supply Voltage(V <sub>S</sub> )	5 V	7.5 V	9 V	12 V	
R <sub>BIAS</sub>	220 Ω	470 Ω	620 Ω	910 Ω	

Note: R<sub>BIAS</sub> provides DC bias stability over temperature.

**Evaluation Board Layout**

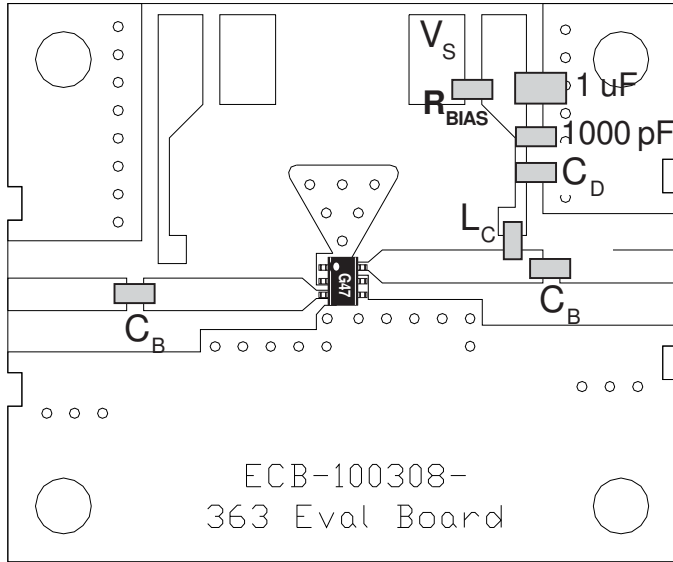

**Mounting Instructions**

1. Use a large ground pad area near device pins 1, 2, 4, and 5 with many plated through-holes as shown.
2. We recommend 1 or 2 ounce copper. Measurements for this data sheet were made on a 31 mil thick FR-4 board with 1 ounce copper on both sides.

### Part Identification Marking

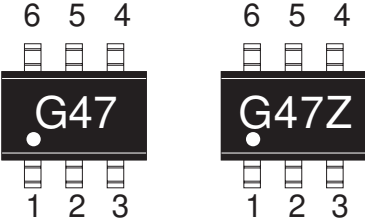

### Alternate Marking with Trace Code Only

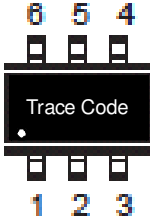

### Ordering Information

Part Number	Reel Size	Devices/Reel
SGA-0363	7"	3000
SGA-0363Z	7"	3000