



Chipsmall Limited consists of a professional team with an average of over 10 year of expertise in the distribution of electronic components. Based in Hongkong, we have already established firm and mutual-benefit business relationships with customers from,Europe,America and south Asia,supplying obsolete and hard-to-find components to meet their specific needs.

With the principle of “Quality Parts,Customers Priority,Honest Operation,and Considerate Service”,our business mainly focus on the distribution of electronic components. Line cards we deal with include Microchip,ALPS,ROHM,Xilinx,Pulse,ON,Everlight and Freescale. Main products comprise IC,Modules,Potentiometer,IC Socket,Relay,Connector.Our parts cover such applications as commercial,industrial, and automotives areas.

We are looking forward to setting up business relationship with you and hope to provide you with the best service and solution. Let us make a better world for our industry!



Contact us

Tel: +86-755-8981 8866 Fax: +86-755-8427 6832

Email & Skype: info@chipsmall.com Web: www.chipsmall.com

Address: A1208, Overseas Decoration Building, #122 Zhenhua RD., Futian, Shenzhen, China



THIS COPY IS PROVIDED ON A RESTRICTED BASIS AND IS NOT TO BE USED IN ANY WAY DETRIMENTAL TO THE INTERESTS OF PANDUIT CORP.

NO WARRANTY, EXPRESSED OR IMPLIED IS MADE BY PANDUIT WITH RESPECT TO ADHESIVE BOND PERFORMANCE. AMONG OTHER THINGS, THE CONDITIONS UNDER WHICH THESE MOUNTS MAY BE APPLIED AND / OR THE SURFACE TO WHICH THEY MAY BE APPLIED ARE BEYOND PANDUIT'S CONTROL.

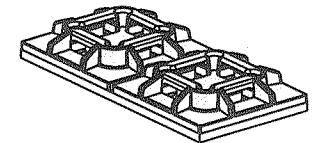
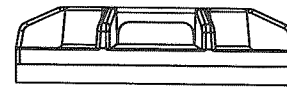
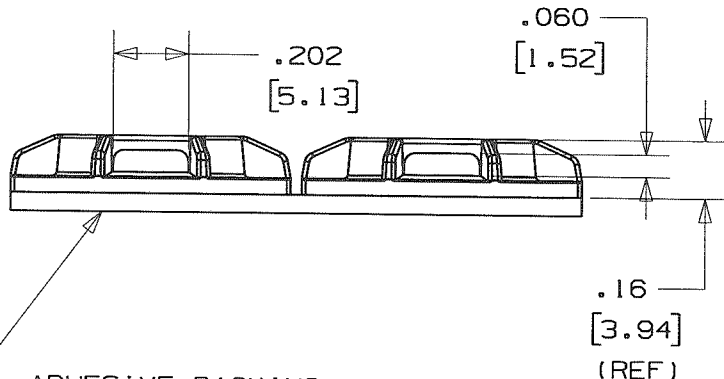
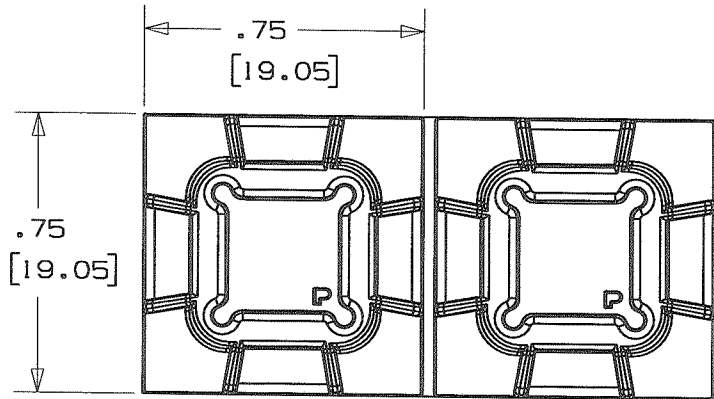

ADHESIVE BACKING:

- *[-A] RUBBER BASED ADHESIVE PRESSURE SENSITIVE FOAM TAPE 0.04 (1.0) THICK WITH A PROTECTIVE LINER. MOUNT IS DESIGNED TO SUPPORT 0.28 lbs (127g) MAX. WEIGHT ON A CLEAN DRY SMOOTH SURFACE.
- *[-AT] ACRYLIC BASED ADHESIVE PRESSURE SENSITIVE FOAM TAPE 0.04 (1.0) THICK WITH A PROTECTIVE LINER. MOUNT IS DESIGNED TO SUPPORT 0.28 lbs (127g) MAX. ON A CLEAN DRY SMOOTH SURFACE.
- *[-AV] HIGH BOND ACRYLIC BASED ADHESIVE PRESSURE SENSITIVE FOAM TAPE 0.04 (1.0) THICK WITH A PROTECTIVE LINER. MOUNT IS DESIGNED TO SUPPORT 0.56 lbs (254g) MAX. ON A CLEAN DRY SMOOTH SURFACE.

PANDUIT PART NO. *	REC'M FASTENER	USE WITH THESE CABLE TIE CROSS SECTIONS	WEIGHT lbs / 100 (g) / pcs
SGABM20-A ABM20 PAM075NY-A	RUBBER ADHESIVE	M, I, SG100M, SG150I	0.142 (64.4)
SGABM20-AT ABM20B	ACRYLIC ADHESIVE		
SGABM20-AV	HIGH BOND ACRYLIC ADHESIVE		

NOTES

- SEE CURRENT PRICE SHEET FOR PART NUMBER SUFFIX DESIGNATION FOR PACKAGE SIZE AND COLOR.
- PRODUCT IS SUPPLIED IN STRIPS OF TWO.
- [-A] MOUNT HAS A MAXIMUM CONTINUOUS OPERATING TEMPERATURE OF 120°F (49°C).
[-AT] MOUNT HAS A MAXIMUM CONTINUOUS OPERATING TEMPERATURE OF 180°F (82°C).
[-AV] MOUNT HAS A MAXIMUM CONTINUOUS OPERATING TEMPERATURE OF 200°F (93°C).
SCALE: FULL

DIMENSIONS IN BRACKETS ARE METRIC [mm]

CAD FILENAME/LAYERS

G03150FB_PB_SGABM20_00B

PANDUIT CORP.

TINLEY PARK, ILLINOIS

ADHESIVE BACKED MOUNT - SUPER GRIP
COMPATIBLE (SGABM20-A, -AT, -AV);
(ABM20, 20B); (PAM075NY-A,)

UNLESS OTHERWISE SPECIFIED,
DIMENSIONAL TOLERANCES ARE:
[.X] ±0.05 (1.3) [XXX] ±0.010 (0.25)
[.XX] ±0.02 (0.5) ANGLES ±5°

UNLESS OTHERWISE SPECIFIED,
ALL DIMENSIONS ARE GIVEN
IN INCHES, THIRD ANGLE
PROJECTION.

DRAWN BY
JAD

MAT'L:

SCALE

DATE
6/12/06

NYLON 6/6

DRAWING NO.

GB3150FB

DWG

A

OOB	REV	DATE	BY	CHK	DESCRIPTION	ECN	- R	CUST	SUP
11-6-09			TMSA	SMY	ADDED PART NUMBER SGABM20-AV	GB3150FB		00B	KW