



Chipsmall Limited consists of a professional team with an average of over 10 year of expertise in the distribution of electronic components. Based in Hongkong, we have already established firm and mutual-benefit business relationships with customers from,Europe,America and south Asia,supplying obsolete and hard-to-find components to meet their specific needs.

With the principle of “Quality Parts,Customers Priority,Honest Operation,and Considerate Service”,our business mainly focus on the distribution of electronic components. Line cards we deal with include Microchip,ALPS,ROHM,Xilinx,Pulse,ON,Everlight and Freescale. Main products comprise IC,Modules,Potentiometer,IC Socket,Relay,Connector.Our parts cover such applications as commercial,industrial, and automotives areas.

We are looking forward to setting up business relationship with you and hope to provide you with the best service and solution. Let us make a better world for our industry!



## Contact us

Tel: +86-755-8981 8866 Fax: +86-755-8427 6832

Email & Skype: info@chipsmall.com Web: www.chipsmall.com

Address: A1208, Overseas Decoration Building, #122 Zhenhua RD., Futian, Shenzhen, China



THIS COPY IS PROVIDED ON A RESTRICTED BASIS AND IS NOT TO BE USED IN ANY WAY DETRIMENTAL TO THE INTERESTS OF PANDUIT CORP.

NO WARRANTY, EXPRESSED OR IMPLIED IS MADE BY PANDUIT WITH RESPECT TO ADHESIVE BOND PERFORMANCE. AMONG OTHER THINGS, THE CONDITIONS UNDER WHICH THESE MOUNTS MAY BE APPLIED AND / OR THE SURFACE TO WHICH THEY MAY BE APPLIED ARE BEYOND PANDUIT'S CONTROL.

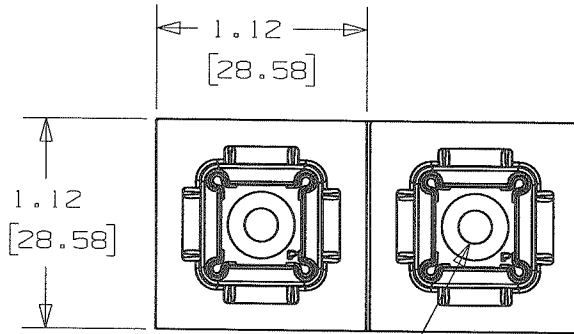

SEE NOTE 3

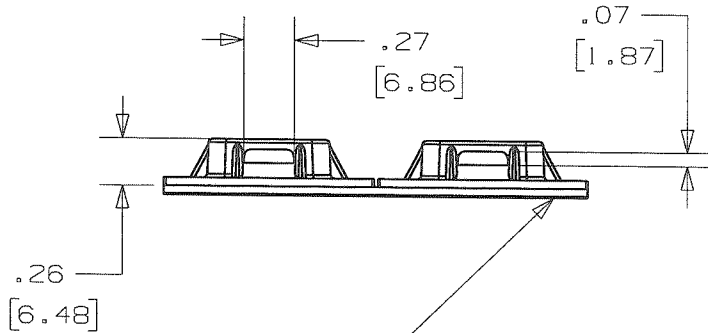

ADHESIVE BACKING:

- \*[-A] RUBBER BASED ADHESIVE PRESSURE SENSITIVE FOAM TAPE 0.04 (1.0) THICK WITH A PROTECTIVE LINER. MOUNT IS DESIGNED TO SUPPORT 0.63 lbs (287g) MAX. WEIGHT ON A CLEAN DRY SMOOTH SURFACE.
- \*[-AT] ACRYLIC BASED ADHESIVE PRESSURE SENSITIVE FOAM TAPE 0.04 (1.0) THICK WITH A PROTECTIVE LINER. MOUNT IS DESIGNED TO SUPPORT 0.63 lbs (287g) MAX. ON A CLEAN DRY SMOOTH SURFACE.
- \*[-AV] HIGH BOND ACRYLIC BASED ADHESIVE PRESSURE SENSITIVE FOAM TAPE 0.04 (1.0) THICK WITH A PROTECTIVE LINER. MOUNT IS DESIGNED TO SUPPORT 1.25 lbs (567g) MAX. ON A CLEAN DRY SMOOTH SURFACE.

PANDUIT PART NO. *	RECOMMENDED FASTENER	USE WITH THESE CABLE TIE CROSS SECTIONS	WEIGHT LBS / 100 (g) / PCS
SGABM30-A ABM30	RUBBER ADHESIVE	M, I, S,	0.42 (188.4)
SGABM30-AT ABM30B	ACRYLIC ADHESIVE	SG100M, SG150I, SG200S, SG250S, SG300S, SG370S	
SGABM30-AV	HIGH BOND ACRYLIC ADHESIVE		

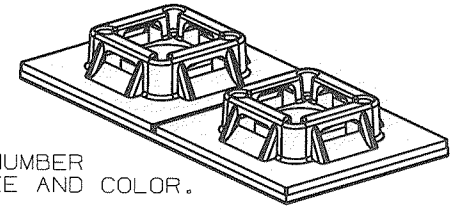

NOTES

1. SEE CURRENT PRICE SHEET FOR PART NUMBER SUFFIX DESIGNATION FOR PACKAGE SIZE AND COLOR.
2. PRODUCT IS SUPPLIED IN STRIPS OF TWO.
3. HOLE FOR STANDARD #8 FLAT HEAD SCREW.
4. -A HAS A CONTINUOUS OPERATING TEMPERATURE OF 120°F (49°C).  
-AT HAS A CONTINUOUS OPERATING TEMPERATURE OF 180°F (82°C).  
-AV HAS A CONTINUOUS OPERATING TEMPERATURE OF 200°F (93°C).

DIMENSIONS IN BRACKETS ARE METRIC [mm]

CAO FILENAME/LAYERS G03587HG\_DC\_GB3150FD/00B

**PANDUIT** CORP. TINLEY PARK, ILLINOIS

ADHESIVE BACKED MOUNT -SUPER GRIP  
COMPATIBLE (SGABM30-A, AT, AV) &  
ABM30, ABM30B

UNLESS OTHERWISE SPECIFIED,  
DIMENSIONAL TOLERANCES ARE:  
(.X) ±0.05 (1.3) (.XXX) ±0.010 (0.25)  
(.XX) ±0.02 (0.5) ANGLES ±5°

UNLESS OTHERWISE SPECIFIED,  
ALL DIMENSIONS ARE GIVEN  
IN INCHES, THIRD ANGLE  
PROJECTION.

DRAWN BY JAD

MAT'L:

SCALE FULL

DATE 3/30/06

NYLON 6/6

DRAWING NO. GB3150FD

DWG  
A  
SIZE

OOB	11-6-09	TMSA	SMY	ADDED PART NUMBER SGABM30-AV-___	GB3150FD	OOB	KEN		
REV	DATE	BY	CHK	DESCRIPTION	ECN	- R	CUST	SUP	