



Chipsmall Limited consists of a professional team with an average of over 10 year of expertise in the distribution of electronic components. Based in Hongkong, we have already established firm and mutual-benefit business relationships with customers from,Europe,America and south Asia,supplying obsolete and hard-to-find components to meet their specific needs.

With the principle of “Quality Parts,Customers Priority,Honest Operation,and Considerate Service”,our business mainly focus on the distribution of electronic components. Line cards we deal with include Microchip,ALPS,ROHM,Xilinx,Pulse,ON,Everlight and Freescale. Main products comprise IC,Modules,Potentiometer,IC Socket,Relay,Connector.Our parts cover such applications as commercial,industrial, and automotives areas.

We are looking forward to setting up business relationship with you and hope to provide you with the best service and solution. Let us make a better world for our industry!



Contact us

Tel: +86-755-8981 8866 Fax: +86-755-8427 6832

Email & Skype: info@chipsmall.com Web: www.chipsmall.com

Address: A1208, Overseas Decoration Building, #122 Zhenhua RD., Futian, Shenzhen, China



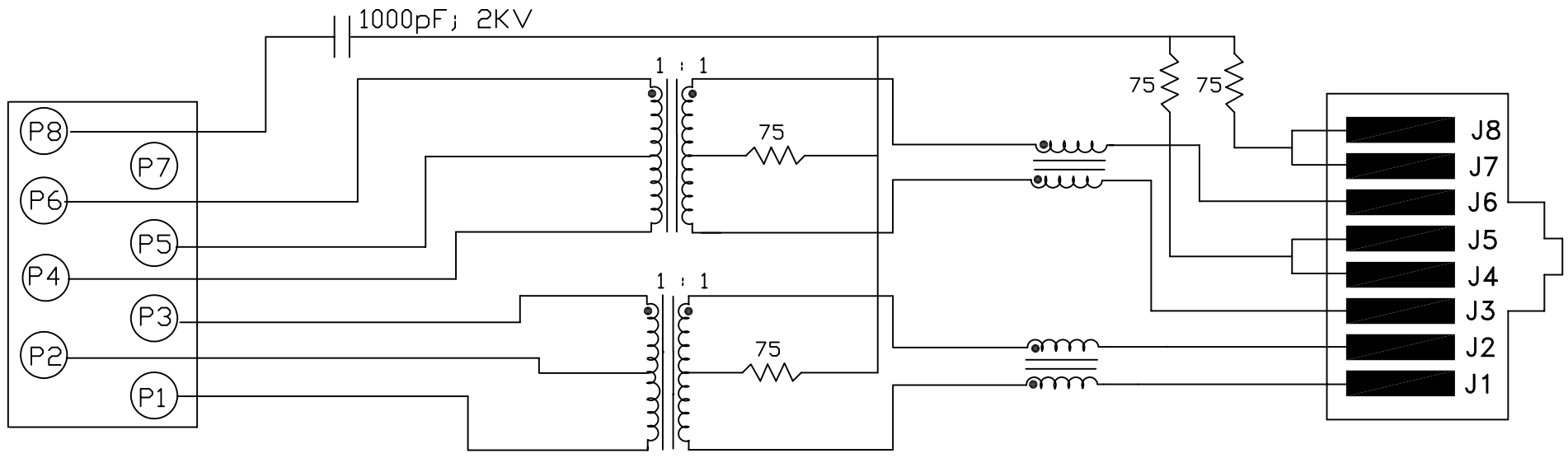

ELECTRICAL SPECIFICATIONS:

- 1.0 TURNS RATIO: $(P6-P5-P4) : (J6-J3)$: 1CT : 1CT ± 3%
 $(P3-P2-P1) : (J2-J1)$: 1CT : 1CT ± 3%
- 2.0 INDUCTANCE: $(P6-P4)$: 350uH MIN. @ 0.1V, 100KHz, 8mA DC Bias
 $(P3-P1)$: 350uH MIN. @ 0.1V, 100KHz, 8mA DC Bias
- 3.0 LEAKAGE INDUCTANCE: P6-P4 (WITH J6 AND J3 SHORT) : 0.3 MAX. @ 1MHZ
P3-P1 (WITH J2 AND J1 SHORT) : 0.3 MAX. @ 1MHZ
- 4.0 INTERWINDING CAPACITANCE: $(P6,P5,P4)$ TO $(J6,J3)$: 30pf MAX @ 1MHZ
 $(P3,P2,P1)$ TO $(J2,J1)$: 30pf MAX. @ 1MHZ
- 5.0 DC RESISTANCE: $(J6-J3)=(J2-J1)$: 1.2 ohms Max.

NOTES

1.0 PINS WITHOUT ELECTRICAL CONNECTION ARE OMITTED.

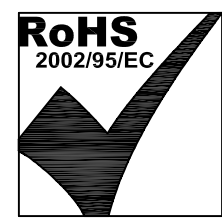

Bel Stewart Connector
 11118 Susquehanna Trail, South
 Glen Rock, Pa 17327-9199
 717.234.7512



<http://www.stewartconnector.com>

THIS DRAWING AND THE SUBJECT MATTER SHOWN THEREON ARE CONFIDENTIAL AND PROPERTY OF BEL STEWART CONNECTOR AND SHALL NOT BE REPRODUCED, COPIED, OR USED IN ANY MANNER WITHOUT PRIOR WRITTEN CONTENT OF BEL STEWART CONNECTOR. THE SUBJECT MATTER MAY BE PATENTED OR A PATENT MAY BE PENDING.

SHEET 1 OF 4	DRAWING NO. SI-60005-F	REV. 17
--------------	------------------------	---------

RECEIVE

- 6.0 RETURN LOSS: 1MHz TO 30MHz : 18dB MIN.
60MHz TO 80MHz : 12dB MIN.
NOTE: 100 OHMS CONNECTED TO (J2-J1) OR (J6-J3).
- 7.0 DIELECTRIC WITHSTAND: (J1, J2) TO (P1, P3) : 1500 VAC
(J3, J6) TO (P4,P6) : 1500 VAC
- 8.0 INSERTION LOSS: RS=RL=100 ohms : 1.1 dB TYP
100kHz TO 100MHz
- 9.0 RISE TIME: RS=100 OHMS AND RL = 100 OHMS : 3.0 nS MAX
OUTPUT VOLTAGE = 1 V peak : 3.0 nS MAX
PULSE WIDTH= 112nS
- 10.0 CROSS TALK: 1MHz TO 100MHz : 40 dB TYP
- 11.0 COMMON TO COMMON MODE ATTENUATION: 30MHz TO 100MHz : 35dB TYP

Bel Stewart Connector
11118 Susquehanna Trail, South
Glen Rock, Pa 17327-9199
717.234.7512

MagJack[®]

<http://www.stewartconnector.com>

THIS DRAWING AND THE SUBJECT MATTER SHOWN THEREON ARE CONFIDENTIAL AND PROPERTY OF BEL STEWART CONNECTOR AND SHALL NOT BE REPRODUCED, COPIED, OR USED IN ANY MANNER WITHOUT PRIOR WRITTEN CONTENT OF BEL STEWART CONNECTOR. THE SUBJECT MATTER MAY BE PATENTED OR A PATENT MAY BE PENDING.

SHEET 2 OF 4

DRAWING NO. SI-60005-F

REV. 17

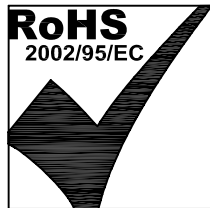
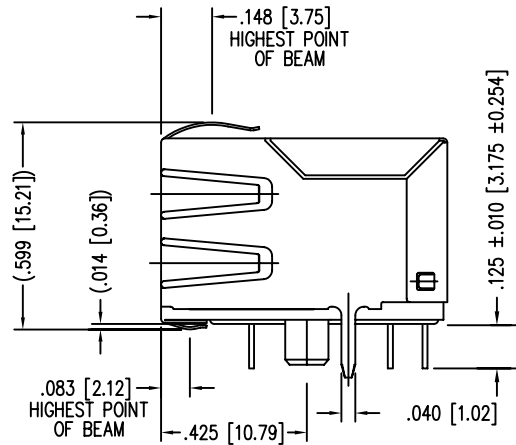
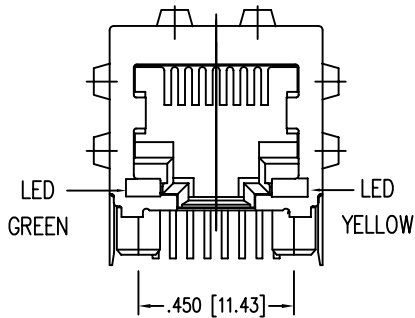
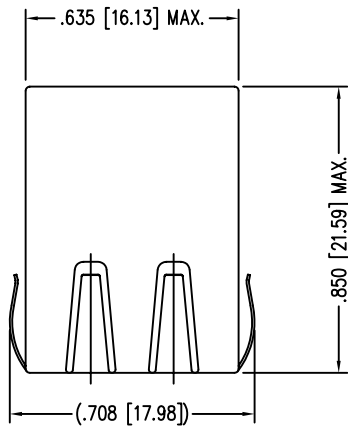

LED SPECIFICATION			
STANDARD LED	WAVELENGTH	FORWARD V (MAX)	* (TYP)
GREEN	565 nm	2.5 V	2.2 V
YELLOW	590 nm	2.5 V	2.1 V

*WITH A FORWARD CURRENT OF 20 mA (TYP)

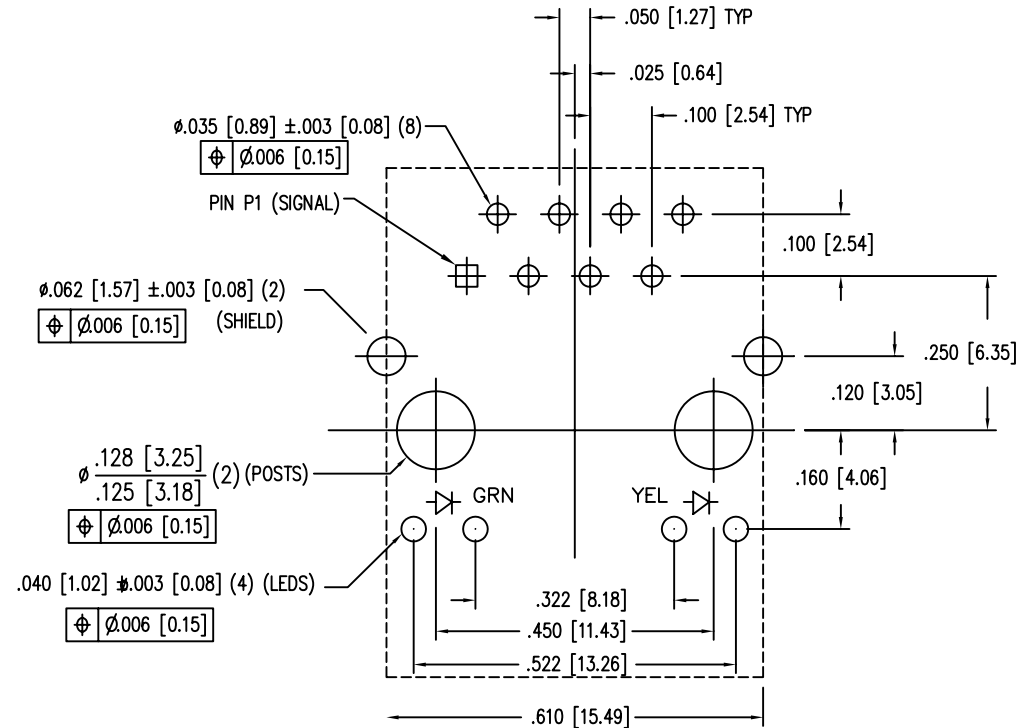

P.C.B. RECOMMENDED HOLE LAYOUT
SEEN FROM COMPONENT SIDE

ALL CENTERLINE DIMENSIONS ARE BASIC.

NOTES:

- CONNECTOR MATERIALS:
HOUSING: THERMOPLASTIC UL94 V-0
CONTACT/SHIELD: COPPER ALLOY
SHIELD PLATING: NICKEL OR TIN
CONTACT PLATING: SELECTIVE GOLD,
50 MICRO-INCHES MIN. IN CONTACT AREA.
- PIN NOT ELECTRICALLY CONNECTED MAYBE OMITTED.
SEE ELECTRICAL DRAWING FOR OMITTED PINS.
- TOLERANCES COMPLY WITH F.C.C. DIMENSION REQUIREMENTS.
- ALL TOLERANCES NOT OTHERWISE SPECIFIED TO BE ±.005 [0.13]
- REFLOW AND WAVE SOLDER COMPATIBLE-260°C FOR
10 SECONDS MAX.

Bel Stewart Connector

11118 Susquehanna Trail, South
Glen Rock, Pa 17327-9199
717.234.7512

MagJack

<http://www.stewartconnector.com>

THIS DRAWING AND THE SUBJECT MATTER SHOWN THEREON ARE CONFIDENTIAL AND PROPERTY OF BEL STEWART CONNECTOR AND SHALL NOT BE REPRODUCED, COPIED, OR USED IN ANY MANNER WITHOUT PRIOR WRITTEN CONTENT OF BEL STEWART CONNECTOR. THE SUBJECT MATTER MAY BE PATENTED OR A PATENT MAY BE PENDING.

SHEET 3 OF 4

DRAWING NO. SI-60005-F

REV. 10

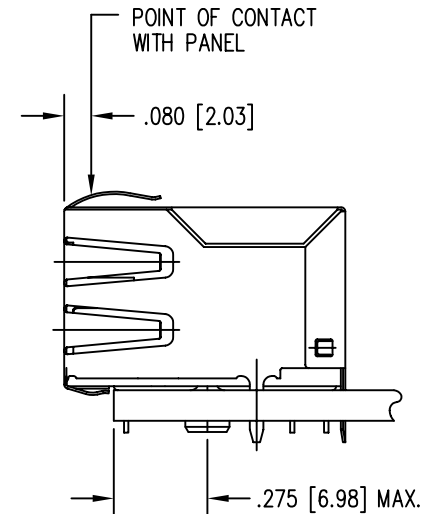
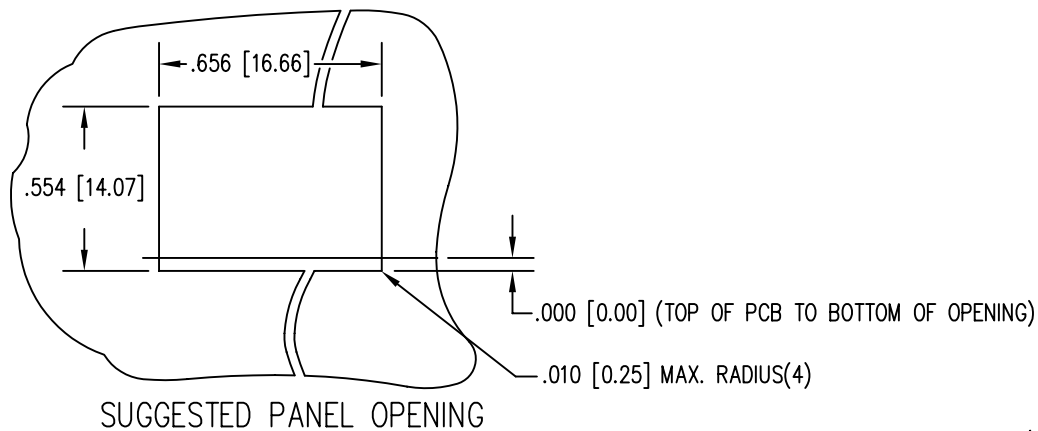

1. THE SUGGESTED PANEL OPENING IS INTENDED TO GIVE THE USER THE ABILITY TO HAVE REASONABLE JACK / PANEL CLEARANCES YET MAINTAIN RELIABLE GROUNDING CAPABILITY.
2. ALL TOLERANCES NOT OTHERWISE SPECIFIED TO BE ± 0.005 [0.13]

Bel Stewart Connector
 11118 Susquehanna Trail, South
 Glen Rock, Pa 17327-9199
 717.234.7512

MagJack[®]

<http://www.stewartconnector.com>

THIS DRAWING AND THE SUBJECT MATTER SHOWN THEREON ARE CONFIDENTIAL AND PROPERTY OF BEL STEWART CONNECTOR AND SHALL NOT BE REPRODUCED, COPIED, OR USED IN ANY MANNER WITHOUT PRIOR WRITTEN CONTENT OF BEL STEWART CONNECTOR. THE SUBJECT MATTER MAY BE PATENTED OR A PATENT MAY BE PENDING.

SHEET
4 OF 4

DRAWING NO.
SI-60005-F

REV.
10