



Chipsmall Limited consists of a professional team with an average of over 10 year of expertise in the distribution of electronic components. Based in Hongkong, we have already established firm and mutual-benefit business relationships with customers from,Europe,America and south Asia,supplying obsolete and hard-to-find components to meet their specific needs.

With the principle of “Quality Parts,Customers Priority,Honest Operation,and Considerate Service”,our business mainly focus on the distribution of electronic components. Line cards we deal with include Microchip,ALPS,ROHM,Xilinx,Pulse,ON,Everlight and Freescale. Main products comprise IC,Modules,Potentiometer,IC Socket,Relay,Connector.Our parts cover such applications as commercial,industrial, and automotives areas.

We are looking forward to setting up business relationship with you and hope to provide you with the best service and solution. Let us make a better world for our industry!



Contact us

Tel: +86-755-8981 8866 Fax: +86-755-8427 6832

Email & Skype: info@chipsmall.com Web: www.chipsmall.com

Address: A1208, Overseas Decoration Building, #122 Zhenhua RD., Futian, Shenzhen, China



DC-to-DC Step-Down Converter

Features and Benefits

- 3.5 A output current supplied in a small, surface mount power package
- High efficiency: 83% at $V_{IN}=15\text{ V}$, $I_O=2.0\text{ A}$, $V_O=5\text{ V}$
- Requires only six external components (optional soft start requires an additional capacitor)
- Oscillation circuit built-in (frequency 300 kHz typical)
- Constant-current mode overcurrent protection circuit and overtemperature protection circuit built-in
- Soft start function built-in (can be implemented as an on/off function; output-off state at low level)
- Low current consumption during output-off state

Package: TO263-5

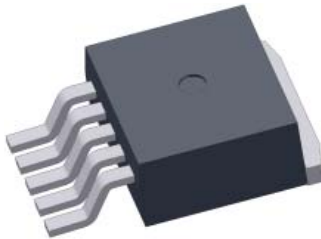

Not to scale

Description

The SI-8001FDE DC voltage regulator is a DC-to-DC buck convertor that attains an oscillation frequency of 300 kHz, and has an integrated miniaturized choke coil, allowing it to serve as a small, high efficiency power supply in a compact TO263 package.

The internal switching regulator function provides high efficiency switching regulation without any need for adjustment. The device requires only six external support components. The optional soft start function requires an additional capacitor. Optional on/off control can be performed using a transistor. The SI-8001FDE includes overcurrent and overtemperature protection circuits.

Applications include:

- DVD recorder
- FPD TV
- Telecommunications equipment
- Office automation equipment, such as printers
- On-board local power supply
- Output voltage regulator for second stage of SMPS (switched mode power supply)

Functional Block Diagram

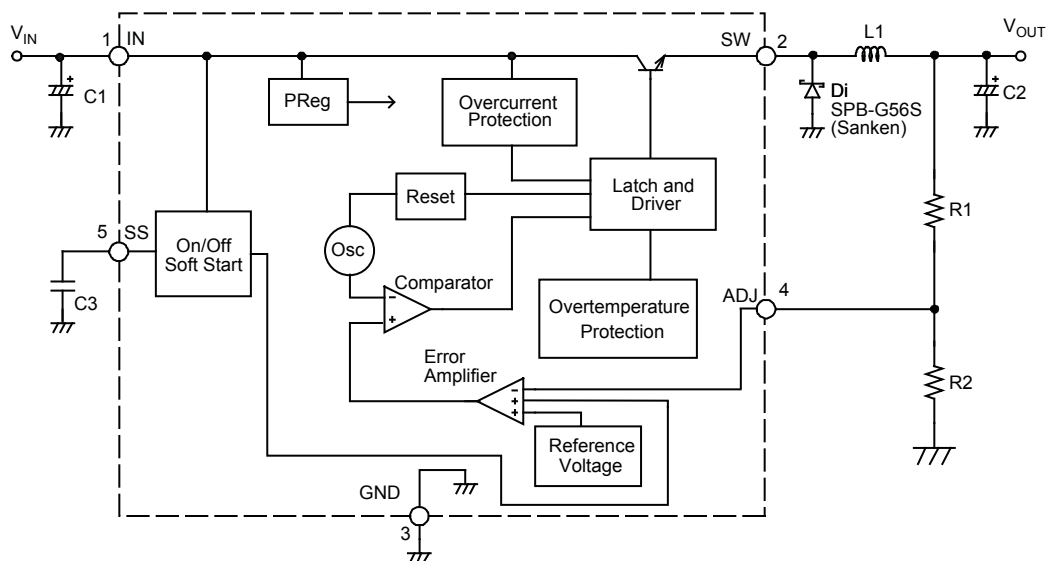

Selection Guide

Part Number	Output Voltage Adjustable Range (V)	Efficiency, Typ. (%)	Input Voltage, Max. (V)	Output Current, Max. (A)	Packing
SI-8001FDE-TL	0.8 to 24	83	40	3.5	800 pieces per reel

Absolute Maximum Ratings

Characteristic	Symbol	Remarks	Rating	Units
DC Input Voltage	V_{IN}		43	V
Power Dissipation	P_D	Mounted on 40 mm × 40 mm exposed copper area on 40 mm × 40 mm glass-epoxy PCB; limited by internal overtemperature protection.	3	W
Junction Temperature	T_J	Internal overtemperature protection circuit may enable when $T_J \geq 130^\circ\text{C}$. During product operation, recommended $T_J \leq 125^\circ\text{C}$.	-40 to 150	$^\circ\text{C}$
Storage Temperature	T_{stg}		-40 to 150	$^\circ\text{C}$
Thermal Resistance (junction-to-case)	$R_{\theta JC}$	Mounted on 40 mm × 40 mm exposed copper area on 40 mm × 40 mm glass-epoxy PCB.	3	$^\circ\text{C/W}$
Thermal Resistance (junction-to-ambient air)	$R_{\theta JA}$	Mounted on 40 mm × 40 mm exposed copper area on 40 mm × 40 mm glass-epoxy PCB.	33.3	$^\circ\text{C/W}$

Recommended Operating Conditions*

Characteristic	Symbol	Remarks	Min.	Max.	Units
DC Input Voltage Range	V_{IN}	$V_{IN}(\text{min})$ is the greater of 4.5 V or $V_O + 3$ V.	See remarks	40	V
DC Output Voltage Range	V_O		0.8	24	V
DC Output Current Range	I_O	$V_{IN} \geq V_O + 3$ V; to be used within the allowable package power dissipation characteristics (refer to Power Dissipation chart).	0	3.5	A
Operating Junction Temperature Range	T_{JOP}		-30	100	$^\circ\text{C}$
Operating Temperature Range	T_{OP}	To be used within the allowable package power dissipation characteristics (refer to Power Dissipation chart).	-30	85	$^\circ\text{C}$

*Required for normal device functioning according to Electrical Characteristics table.

All performance characteristics given are typical values for circuit or system baseline design only and are at the nominal operating voltage and an ambient temperature, T_A , of 25°C , unless otherwise stated.

ELECTRICAL CHARACTERISTICS¹, valid at T_A = 25°C, V_O = 5 V (adjusted), R₁ = 4.2 kΩ, R₁ = 0.8 kΩ

Characteristic	Symbol	Test Conditions ¹	Min.	Typ.	Max.	Units
Reference Voltage	V _{ADJ}	V _{IN} = 15 V, I _O = 0.2 A	0.784	0.800	0.816	V
Reference Voltage Temperature Coefficient	ΔV _{ADJ} /ΔT	V _{IN} = 15 V, I _O = 0.2 A, T _C = 0 to 100 °C	–	±0.1	–	mV/°C
Efficiency ²	η	V _{IN} = 15 V, I _O = 2 A	–	83	–	%
Operating Frequency	f _O	V _{IN} = 15 V, I _O = 2 A	270	300	330	kHz
Line Regulation	V _{Line}	V _{IN} = 10 to 30 V, I _O = 2 A	–	–	80	mV
Load Regulation	V _{Load}	V _{IN} = 15 V, I _O = 0.2 to 3.5 A	–	–	50	mV
Overcurrent Protection Threshold Current	I _S	V _{IN} = 15 V	3.6	–	–	A
SS Terminal On/Off Operation Threshold Voltage	V _{SSL}		–	–	0.5	V
SS Terminal On/Off Operation Outflow Current	I _{SSL}	V _{SSL} = 0 V	–	6	30	μA
Quiescent Current 1	I _q	V _{IN} = 15 V, I _O = 0 A	–	6	–	mA
Quiescent Current 2	I _{q(off)}	V _{IN} = 15 V, V _{SS} = 0 V	–	200	600	μA

¹Using circuit shown in Typical Application Circuit diagram.

²Efficiency is calculated as: $\eta(\%) = ([V_O \times I_O] \times [V_{IN} \times I_{IN}]) \times 100$.

Pin-out Diagram

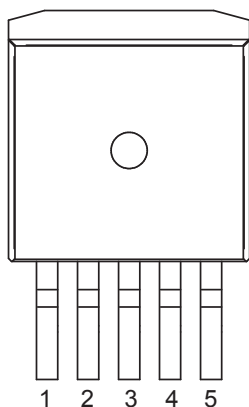

Terminal List Table

Name	Number	Function
IN	1	Supply voltage
SW	2	Regulated supply output
GND	3	Ground terminal
ADJ	4	Terminal for resistor bridge feedback
SS	5	<p>The SS terminal is used to enable soft start and to control on/off operation of the IC output, V_O (see figure 2). If neither soft start nor on/off control is used, leave pin open.</p> <p>To enable soft start, connect a capacitor between SS and ground. To control on/off operation, connect an NPN bipolar transistor, in a TTL open collector output configuration, between the SS terminal and GND. Turn off is done by decreasing V_{SSL} below its rated level.</p> <p>When both soft start and V_O on/off are used, a protection measure such as current limiting is required because, if the capacitance of C3 large, the discharge current of C3 flows across the transistor for on/off operation. Because a pull-up type resistor is provided inside the IC, no external voltage can be applied.</p>

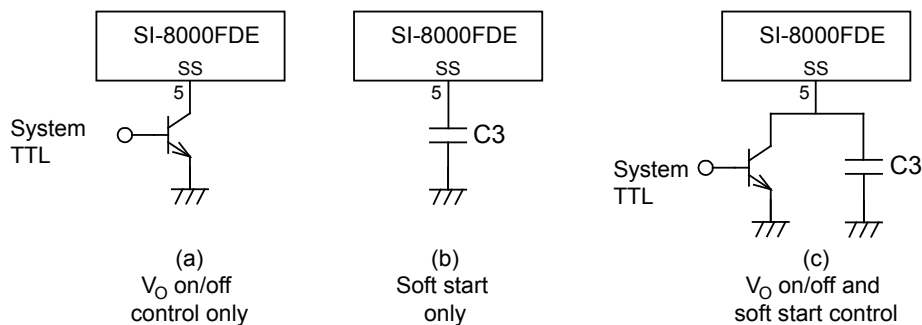
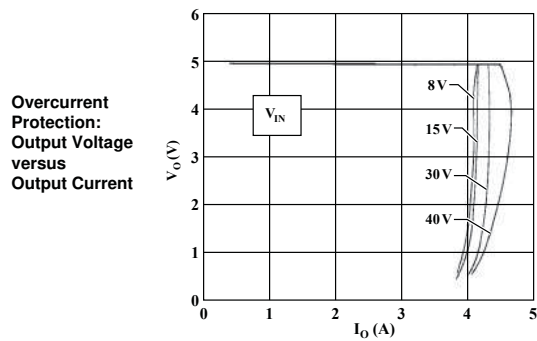
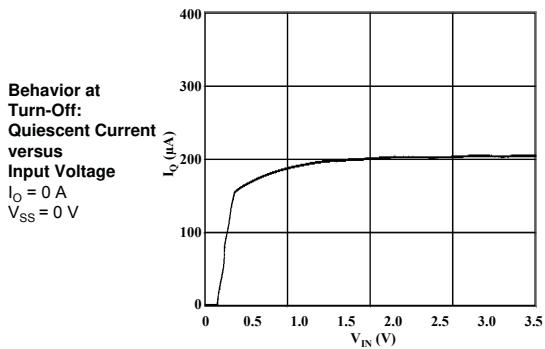
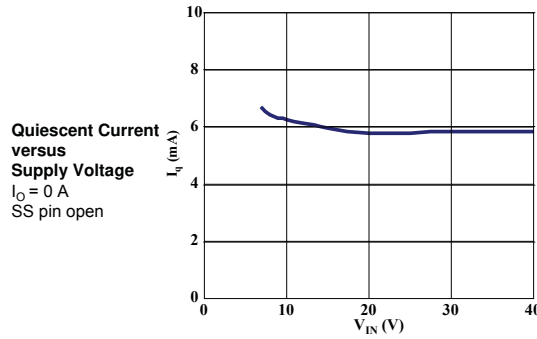
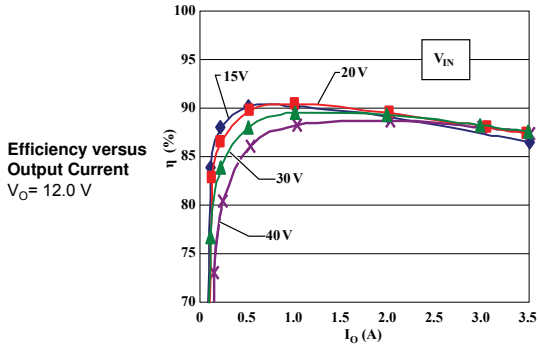
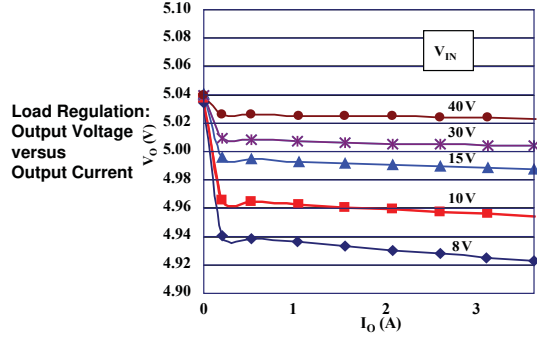
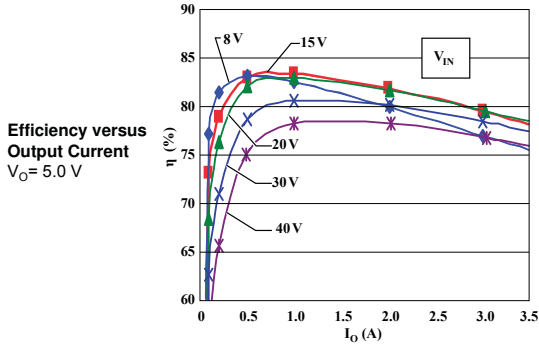
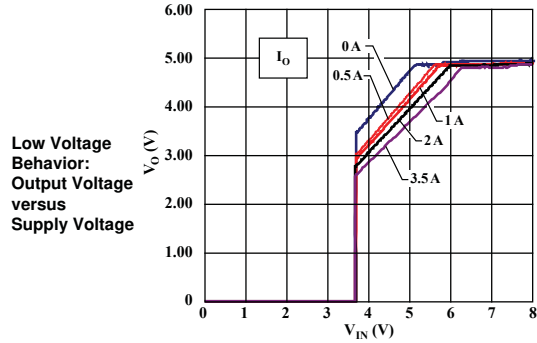
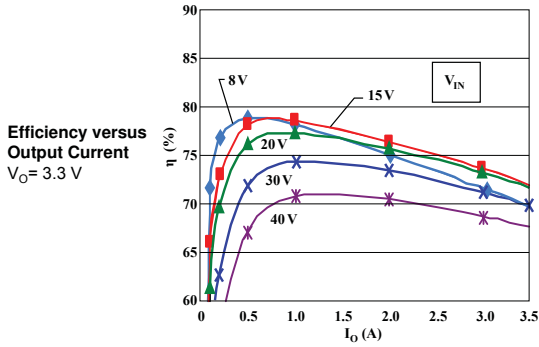

Figure 2. Alternative configurations for SS pin. If neither soft start nor V_O on/off is required, the SS pin is left open.

Performance Characteristics

At $T_A = 25^\circ\text{C}$, $V_O = 5\text{ V}$ Adjusted, $R_1 = 4.2\text{ k}\Omega$, $R_2 = 0.8\text{ k}\Omega$



Thermal Performance Characteristics

The application must be designed to ensure that the $T_J(\text{max})$ of the device is not exceeded during operation. To do so, it is necessary to determine values for maximum power dissipation, $P_D(\text{max})$, and ambient temperature, $T_A(\text{max})$.

The relationships of T_J , P_D , T_A , and case temperature, T_C , are as shown in the following formulas:

$$P_D = \frac{T_J - T_C}{R_{\theta JC}} \quad \text{and} \quad P_D = \frac{T_J - T_A}{R_{\theta JA}}$$

P_D can be calculated from input values:

$$P_D = V_O \cdot I_O \left(\frac{100}{\eta_x} - 1 \right) - V_F \cdot I_O \left(1 - \frac{V_O}{V_{IN}} \right)$$

where:

V_O is output voltage in V,

V_{IN} is input supply voltage in V,

I_O is output current in A,

η_x is IC efficiency in percent (varies with V_{IN} and I_O ; refer to efficiency performance curves for value), and

V_F is forward voltage for the input diode, Di. In these tests, the Sanken SPB-G56S was used, at 0.4 V. For application design, obtain thermal data from the datasheet for the diode.

P_D is substantially affected by the heat conductance properties of the application, in particular any exposed copper area on the PCB where the device is mounted. The relationships of P_D , T_A , and copper area is represented in the Power Dissipation chart.

$R_{\theta JA}$ for a given copper area can be determined from the Device Thermal Resistance chart. This can be substituted into the formula above to determine the $T_J(\text{max})$ allowable in the application. Generally, more than 10% to 20% derating is required.

Because the heat dissipation capacity of the copper area depends substantially on how it is used in the actual application, thermal characteristics of the application must be confirmed by testing. T_C is determined by connecting a thermocouple to the device as shown here:

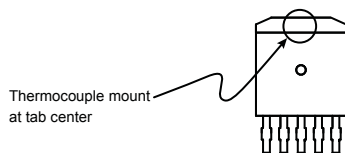

And analyzing the results using the following formula:

$$T_J = P_D \times R_{\theta JC} + T_C$$

for this device, $R_{\theta JC}$ is 3 °C/W.

Power Dissipation versus Ambient Temperature

$T_J(\text{max}) = 125^\circ\text{C}$; Mounted on glass-epoxy PCB (40 mm × 40 mm), with varying exposed copper areas

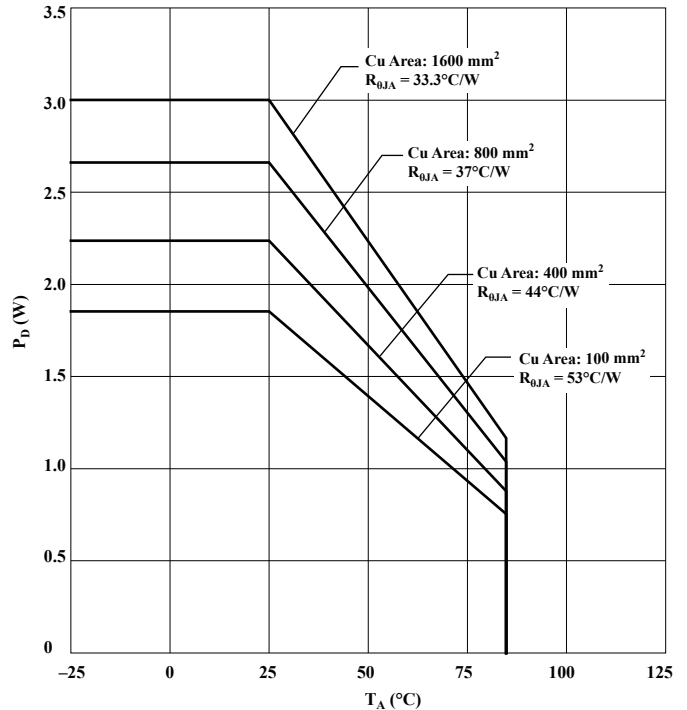

Device Thermal Resistance versus Exposed Copper Area on PCB

Glass-epoxy PCB, 40 mm × 40 mm

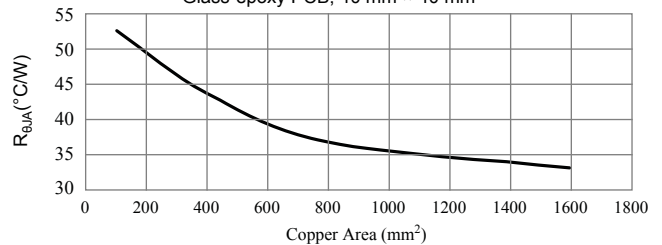

Overtemperature Protection:
Output Voltage versus Junction Temperature
 $V_{IN} = 15 \text{ V}$, $I_O = 10 \text{ mA}$

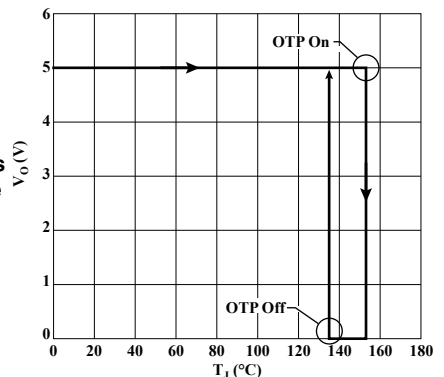

Component Selection

Diode Di A Schottky-barrier diode must be used for Di. If other diode types are used, such as fast recovery diodes, the IC may be destroyed because of the reverse voltage applied by the recovery voltage or ON voltage.

Choke Coil L1 If the winding resistance of the choke coil is too high, the efficiency may be reduced below rating. Because the overcurrent protection start current is approximately 4.2 A, attention must be paid to the heating of the choke coil by magnetic saturation due to overload or short-circuited load.

Capacitors C1, C2, and C3 Because for SMPS, large ripple currents flow across C1 and C2, capacitors with high frequency and low impedance must be used. If the impedance of C2 is too high, the switching waveform may not be normal at low temperatures. Do not use either OS or tantalum types of capacitors for

C2 or C3, because the extremely low ESR causes an abnormal oscillation.

The device is stabilized, and for proper operation, C1 must be located close to the device (see layout diagram, below). C3 is required only if the soft start function is used. If not using soft-start, leave the SS terminal open. A pull-up resistor is provided inside the IC.

Resistor Bridge R1 and R2 R1 and R2 comprise the resistor bridge for the output voltage, V_O , and are calculated as follows:

$$R1 = \frac{(V_O - V_{ADJ})}{I_{ADJ}} = \frac{(V_O - 0.8)}{1 \times 10^{-3}} (\Omega), \text{ and } R2 = \frac{V_{ADJ}}{I_{ADJ}} = \frac{0.8}{1 \times 10^{-3}} = 0.8 (\text{k}\Omega)$$

I_{ADJ} should always be set to 1 mA. Note that R2 should always be present to ensure stable operation, even if V_O is set to 0.8 V (that is, even if there is no R1). V_O should be at least $V_{IN} + 8\%$.

Typical Application Diagram

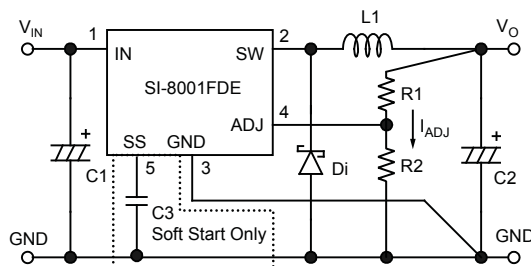

Recommended PCB Layout

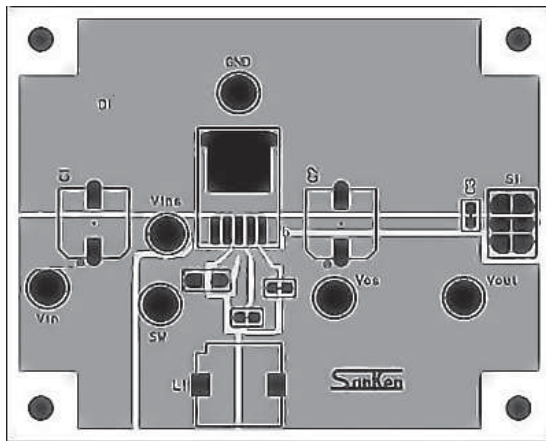

All external components should be mounted as close as possible to the SI-8001FDE. The ground of all components should be connected at one point near GND pin (pin 3).

Component Rating

Component	Rating
C1	470 μ F
C2	680 μ F
C3	0.1 μ F (For soft start function)
Di	SPB-G56S (Sanken)
L1	47 μ H

Recommended Solder Pad Layout

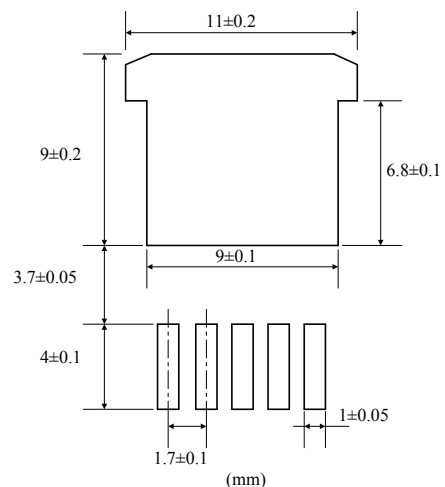

PACKAGE OUTLINE DRAWING

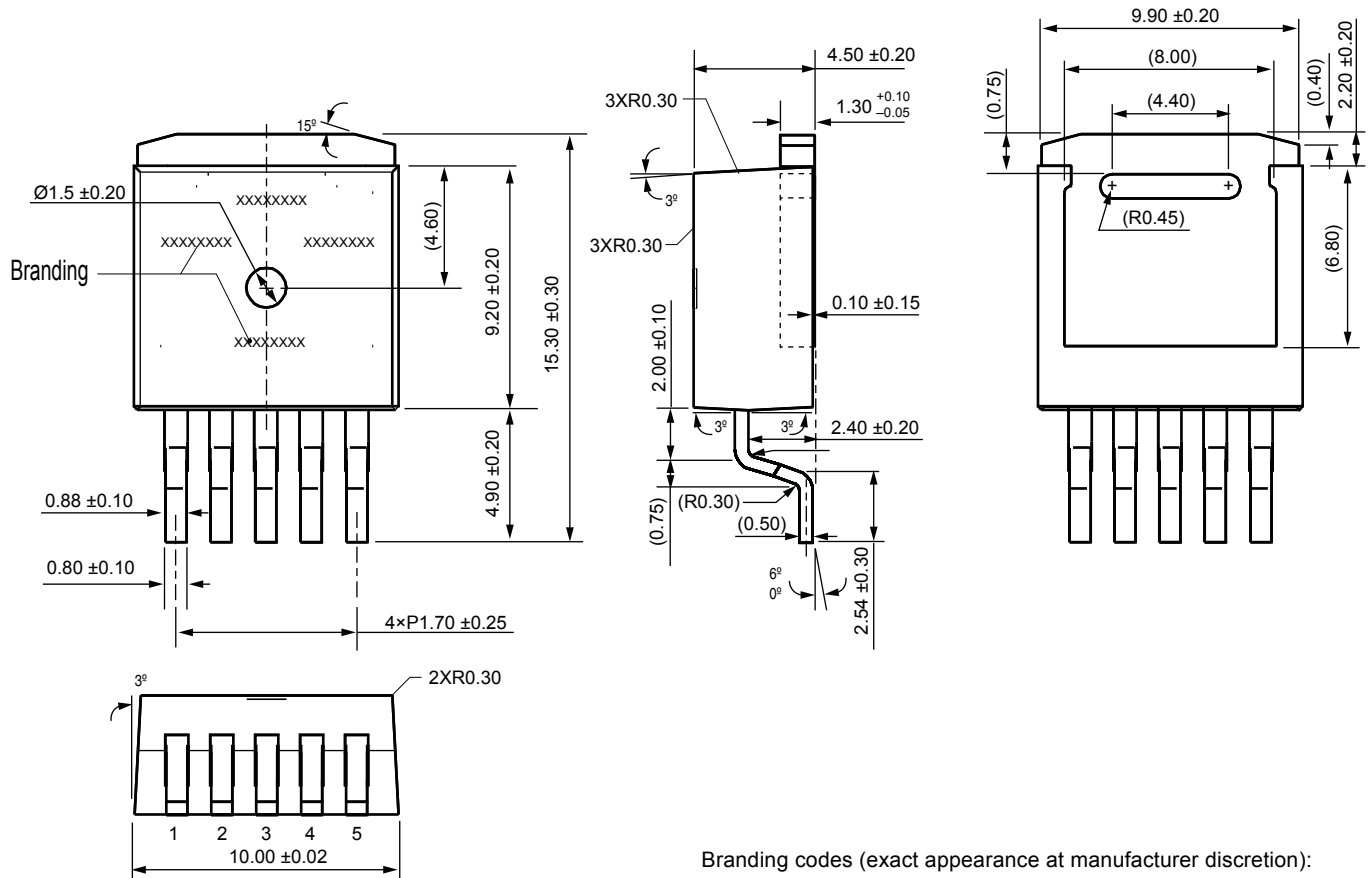

Dimensions do not include mold protrusion
Heatsink side flash: 0.8 mm maximum

Dimensions in millimeters

Branding codes (exact appearance at manufacturer discretion):

1st line: SK
 2nd line, lot: YMW X
 Where: Y is the last digit of the year of manufacture
 M is the month (1 to 9, O, N, D)
 W is the week of the month (1 to 5)
 X is the device subtype suffix number
 3rd line, type: 8001FDE



*RoHS directive compliant
 Device pins lead (Pb) free*

Cautions for Use

- Operation of the product in parallel to increase current is not permitted.
- Although the product has an internal overtemperature protection circuit, that is intended only to protect the product from temporary excess heating due to overloads. Long-term reliability cannot be guaranteed when the product is operated under continuous overload conditions.

Because reliability can be affected adversely by improper storage environments and handling methods, please observe the following cautions.

Cautions for Storage

- Ensure that storage conditions comply with the standard temperature (5°C to 35°C) and the standard relative humidity (around 40 to 75%); avoid storage locations that experience extreme changes in temperature or humidity.
- Avoid locations where dust or harmful gases are present and avoid direct sunlight.
- Reinspect for rust on leads and solderability of products that have been stored for a long time.

Cautions for Testing and Handling

When tests are carried out during inspection testing and other standard test periods, protect the products from power surges from the testing device, shorts between adjacent products, and shorts to the heatsink.

Electrostatic Discharge

- When handling the products, operator must be grounded. Grounded wrist straps worn should have at least 1 MΩ of resistance to ground to prevent shock hazard.
- Workbenches where the products are handled should be grounded and be provided with conductive table and floor mats.
- When using measuring equipment such as a curve tracer, the equipment should be grounded.
- When soldering the products, the head of soldering irons or the

solder bath must be grounded in order to prevent leak voltages generated by them from being applied to the products.

- The products should always be stored and transported in our shipping containers or conductive containers, or be wrapped in aluminum foil.

Soldering

- When manually soldering the products, please be sure to minimize the working time, within the following limits:

Soldering Iron Temperature (°C)	Time (s)
380±10	3 (once only)

- Reflow soldering can be performed a maximum of twice, using the following recommended profile:

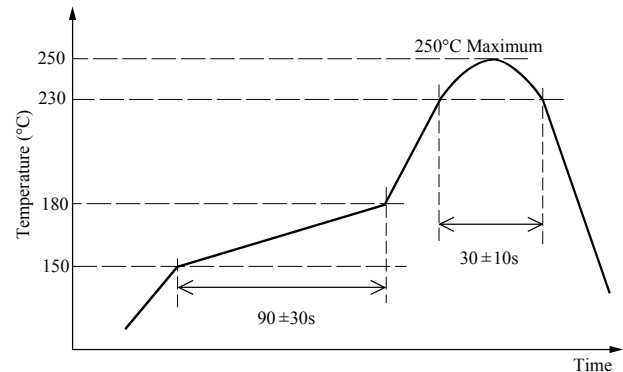

-
- The contents in this document are subject to changes, for improvement and other purposes, without notice. Make sure that this is the latest revision of the document before use.
 - Application and operation examples described in this document are quoted for the sole purpose of reference for the use of the products herein and Sanken can assume no responsibility for any infringement of industrial property rights, intellectual property rights or any other rights of Sanken or any third party which may result from its use.
 - Although Sanken undertakes to enhance the quality and reliability of its products, the occurrence of failure and defect of semiconductor products at a certain rate is inevitable. Users of Sanken products are requested to take, at their own risk, preventative measures including safety design of the equipment or systems against any possible injury, death, fires or damages to the society due to device failure or malfunction.
 - Sanken products listed in this document are designed and intended for the use as components in general purpose electronic equipment or apparatus (home appliances, office equipment, telecommunication equipment, measuring equipment, etc.).

When considering the use of Sanken products in the applications where higher reliability is required (transportation equipment and its control systems, traffic signal control systems or equipment, fire/crime alarm systems, various safety devices, etc.), and whenever long life expectancy is required even in general purpose electronic equipment or apparatus, please contact your nearest Sanken sales representative to discuss, prior to the use of the products herein.

The use of Sanken products without the written consent of Sanken in the applications where extremely high reliability is required (aerospace equipment, nuclear power control systems, life support systems, etc.) is strictly prohibited.

- In the case that you use Sanken products or design your products by using Sanken products, the reliability largely depends on the degree of derating to be made to the rated values. Derating may be interpreted as a case that an operation range is set by derating the load from each rated value or surge voltage or noise is considered for derating in order to assure or improve the reliability. In general, derating factors include electric stresses such as electric voltage, electric current, electric power etc., environmental stresses such as ambient temperature, humidity etc. and thermal stress caused due to self-heating of semiconductor products. For these stresses, instantaneous values, maximum values and minimum values must be taken into consideration.

In addition, it should be noted that since power devices or IC's including power devices have large self-heating value, the degree of derating of junction temperature affects the reliability significantly.

- When using the products specified herein by either (i) combining other products or materials therewith or (ii) physically, chemically or otherwise processing or treating the products, please duly consider all possible risks that may result from all such uses in advance and proceed therewith at your own responsibility.
- Anti radioactive ray design is not considered for the products listed herein.
- Sanken assumes no responsibility for any troubles, such as dropping products caused during transportation out of Sanken's distribution network.
- The contents in this document must not be transcribed or copied without Sanken's written consent.