



Chipsmall Limited consists of a professional team with an average of over 10 year of expertise in the distribution of electronic components. Based in Hongkong, we have already established firm and mutual-benefit business relationships with customers from,Europe,America and south Asia,supplying obsolete and hard-to-find components to meet their specific needs.

With the principle of “Quality Parts,Customers Priority,Honest Operation,and Considerate Service”,our business mainly focus on the distribution of electronic components. Line cards we deal with include Microchip,ALPS,ROHM,Xilinx,Pulse,ON,Everlight and Freescale. Main products comprise IC,Modules,Potentiometer,IC Socket,Relay,Connector.Our parts cover such applications as commercial,industrial, and automotives areas.

We are looking forward to setting up business relationship with you and hope to provide you with the best service and solution. Let us make a better world for our industry!



## Contact us

Tel: +86-755-8981 8866 Fax: +86-755-8427 6832

Email & Skype: info@chipsmall.com Web: www.chipsmall.com

Address: A1208, Overseas Decoration Building, #122 Zhenhua RD., Futian, Shenzhen, China



### Description

A universal hybrid TV tuner, the Si2157 supports digital and analog reception for all worldwide terrestrial and cable TV standards. By combining Silicon Laboratories' proven digital low-IF architecture with a 5<sup>th</sup>-generation RF front-end, the Si2157 maintains the highest performance that exceeds that of MOPLL-based tuners, including industry-leading 2<sup>nd</sup> order distortion performance. Pin- and API-compatibility to the previous generation minimize customers' development effort.

The Si2157 delivers unprecedented integration with no external balun, tracking filters, LNAs, SAW filters, or inductive power supply filtering. While other solutions may also eliminate the balun, they suffer degradation in NF and 2<sup>nd</sup> order distortion compromising reception. Silicon Laboratories' proprietary and field-proven architecture delivers not only an optimized BOM but also world-class system performance. Options for single or dual supply and internal power-on reset are included. A harmonic rejection mixer delivers outstanding immunity to Wi-Fi and LTE interference, replacing the need for external filtering.

For advanced digital terrestrial TV reception, DVB-T2 and DVB-C2 constellations demand outstanding phase noise specifications, and the Si2157 rises to the challenge, delivering industry-leading integrated phase noise. Additionally, a software-selectable cable mode offers optimized return loss.

The Si2157 delivers exceptional picture quality and a higher number of received stations when compared to other solutions. Incorporating worldwide field experience from four prior tuner generations in mass production, the Si2157 delivers the highest tolerance to real-world reception conditions.

### Features

- Worldwide hybrid TV tuner
  - Analog TV: NTSC, PAL/SECAM
  - Digital TV: ATSC/QAM, DVB-T2/T/C2/C, ISDB-T/C, DTMB
- Industry-leading margin to A/74, NorDig, D-Book, C-Book, ARIB, EN55020, OpenCable™ specifications
- Lowest BOM for a silicon hybrid TV tuner
  - No balun
  - No SAW filters or wire-wound inductors
  - Integrated LNAs and complete tracking filters
- Best-in-class real-world reception
  - Exceeds discrete MOPLL-based tuners
  - Industry-leading phase noise performance
  - High immunity to Wi-Fi and LTE interference
- Low power consumption
  - 3.3 V and 1.8 V power supplies
  - Single-supply option for 3.3 V-only operation
- Integrated power-on reset circuit
- Flexible output interface
  - Combined ALIF/DLIF output to SoC
  - Optional DLIF output to external demodulator
- Standard CMOS process technology
- 4x4 mm, 28-pin QFN package
- RoHS compliant

### Applications

- Hybrid 1/2-NIM tuner module
- iDTV (Integrated Digital TV)
- Hybrid terrestrial and cable STB
- Hybrid PVR, DVD and Blu-Ray disc recorder
- PC-TV accessories

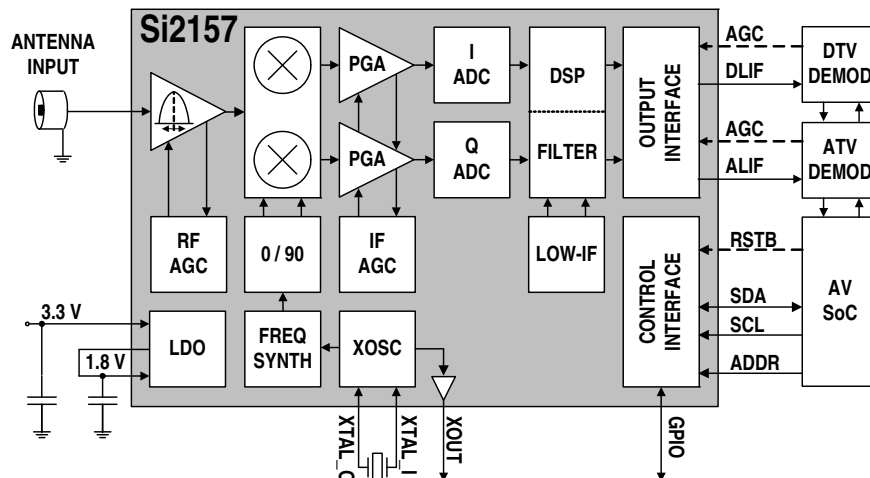

### Selected Electrical Specifications

( $V_{DD\_H}=3.3\text{ V}$ ,  $V_{DD\_L}=1.8\text{ V}$ ,  $V_{DD\_D}=1.8\text{ V}$ ,  $T_A=25\text{ }^\circ\text{C}$ )

Parameter	Test Condition	Typ	Unit
Supply voltage		1.8 and 3.3, or only 3.3	V
Total Power Consumption	ATV Mode, XOUT Disabled	496	mW
RF Input Frequency Range		42 to 870	MHz
NF, terrestrial*	VHF-L	4.0	dB
	VHF-H	3.7	dB
	UHF	3.8	dB
Return Loss*	Terrestrial mode	3	dB
	Cable mode	9	dB
Wideband IIP3*	VHF-H, $N\pm 18, \pm 36$	+5	dBm
Inband IIP3*	VHF-H, $N\pm 1, \pm 2$	-6	dBm
LO Phase Noise at 860 MHz	1 kHz   10 kHz   100 kHz   1 MHz	-100   -100   -105   -132	dBc/Hz
LO Integrated Phase Noise at 860 MHz	DSB: 125 Hz to 4 MHz	0.25 (-47)	$^\circ$ rms (dBc)
Analog IF Spurious Distortion	S=P	-72	dB
ALIF/DLIF Output Center Frequency	channel BW=6 MHz   7 MHz   8 MHz	4 to 7   4.5 to 6.5   5 to 6	MHz
ALIF/DLIF Differential Output Voltage	Programmable	0.5 to 2.0	Vppd

\*Note: Measured at the F-connector input of the Si2157 EVB and includes all connector, PCB, and front-end circuit losses.

### Selection Guide

Part #	Description
Si2157	Worldwide hybrid TV tuner for NTSC, PAL/SECAM, ATSC/QAM, DVB-T2/T/C2/C, ISDB-T/C, DTMB

### Pin Assignments

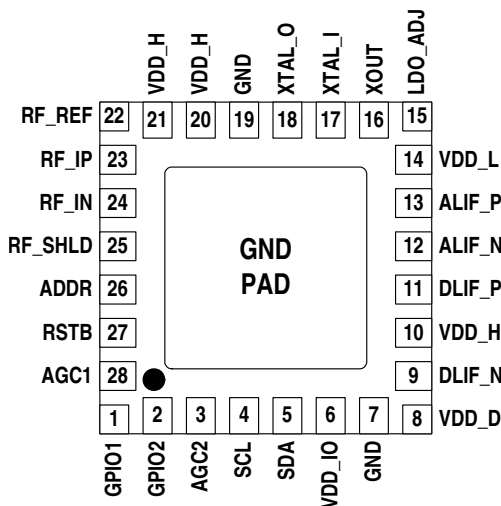

### 4x4 mm QFN-28 Package Information

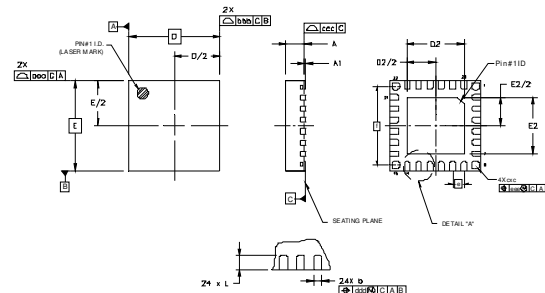

Symbol	Min	Nom	Max	Unit
A	0.80	0.85	0.90	mm
D, E	4.00 BSC			mm
e	0.50 BSC			mm
f	3.50 BSC			mm