



Chipsmall Limited consists of a professional team with an average of over 10 year of expertise in the distribution of electronic components. Based in Hongkong, we have already established firm and mutual-benefit business relationships with customers from,Europe,America and south Asia,supplying obsolete and hard-to-find components to meet their specific needs.

With the principle of “Quality Parts,Customers Priority,Honest Operation,and Considerate Service”,our business mainly focus on the distribution of electronic components. Line cards we deal with include Microchip,ALPS,ROHM,Xilinx,Pulse,ON,Everlight and Freescale. Main products comprise IC,Modules,Potentiometer,IC Socket,Relay,Connector.Our parts cover such applications as commercial,industrial, and automotives areas.

We are looking forward to setting up business relationship with you and hope to provide you with the best service and solution. Let us make a better world for our industry!



Contact us

Tel: +86-755-8981 8866 Fax: +86-755-8427 6832

Email & Skype: info@chipsmall.com Web: www.chipsmall.com

Address: A1208, Overseas Decoration Building, #122 Zhenhua RD., Futian, Shenzhen, China





**Si3402-A-GM to Si3402-B-GM EVB Modifications
Version 0.4**

The Si3402-B-GM device requires component value changes from those used with the Si3402-A-GM evaluation board (EVB) reference design. Table 1 below is a summary of the required modifications.

Following Table 1 are two reference schematic excerpts showing the locations of the modified component values for both the isolated (flyback) and non-isolated (buck) topologies.

Table 1. Si3402-B-GM EVB modifications versus the Si3402-A-GM EVB

Item	Modification description	Application design effect
M1	Detect resistor value change	The former 25.5kΩ detect resistor must be replaced by 24.3kΩ 1%
M2	Classification resistor value change	The following 1% resistors must be used: Class0: 681.00 or higher (It is optional to place this resistor) Class1: 140.0 Class2: 75.0 Class3: 48.7 Class4: 33.2
M3*	ISO EVB DCDC 3.3V changes Flyback	C8, R9 & C23 are not need—Do not populate them. C9=10nF, C21=33nF, R12=475 Ω & R8=1.1k Ω Replace D2 (DFLT15A) with DFLT30A * See Revision Notes
M4	ISO EVB DCDC 5V changes Flyback	C8, R9 & C23 are not need—Do not populate them. C9=3.3nF, C21=15nF, R12=0 & R8=0 (place zero Ω resistors) Replace D2 (DFLT15A) with DFLT30A
M5	ISO EVB DCDC 12V changes Flyback	C8, R9 & C23 are not need—Do not populate them. C9=10nF, C21=15nF, R12=0, R8=0 (place zero Ω resistor) R7=3k Replace D2 (DFLT15A) with DFLT30A
M6	DCDC reference voltage change (Buck case only)	Now 1.35V instead of previous 1.23V. Thus, R5 changes from 2.87kΩ 1% to 3.24kΩ 1%. R6 (1%) is modified according to this table:

		Vout Target	R5 kΩ	R6 kΩ	Vref	Vout Measured
		3.3	3.24	4.64	1.35	3.37
		5	3.24	8.66	1.35	4.96
		9	3.24	18.2	1.35	8.93
		12	3.24	25.5	1.35	11.98
M7	BUCK EVB DCDC 3.3V compensation network changes	C19, C20 & C9 are not need—Do not populate them. R8 can be populated with a 0Ω resistor (creating a short between pins 3 and 4) or left unpopulated, since the ISOSSFT function is now internal (see datasheet). C7=1nF, R7=47kΩ ±20%.				
M8	BUCK EVB DCDC 5V compensation network changes	C19, C20, R8 & C9 are not need—Do not populate them. R8 can be populated with a 0Ω resistor (creating a short between pins 3 and 4) or left unpopulated, since the ISOSSFT function is now internal (see datasheet). C7=1nF, R7=47kΩ ±20%.				
M9	BUCK EVB DCDC 12V compensation network changes	C19, C20, R8 & C9 are not need—Do not populate them. R8 can be populated with a 0Ω resistor (creating a short between pins 3 and 4) or left unpopulated, since the ISOSSFT function is now internal (see datasheet). C7=1nF, R7=47kΩ ±20%.				

Si3402ISO (Flyback, Isolated) EVB Reference Design – 5V

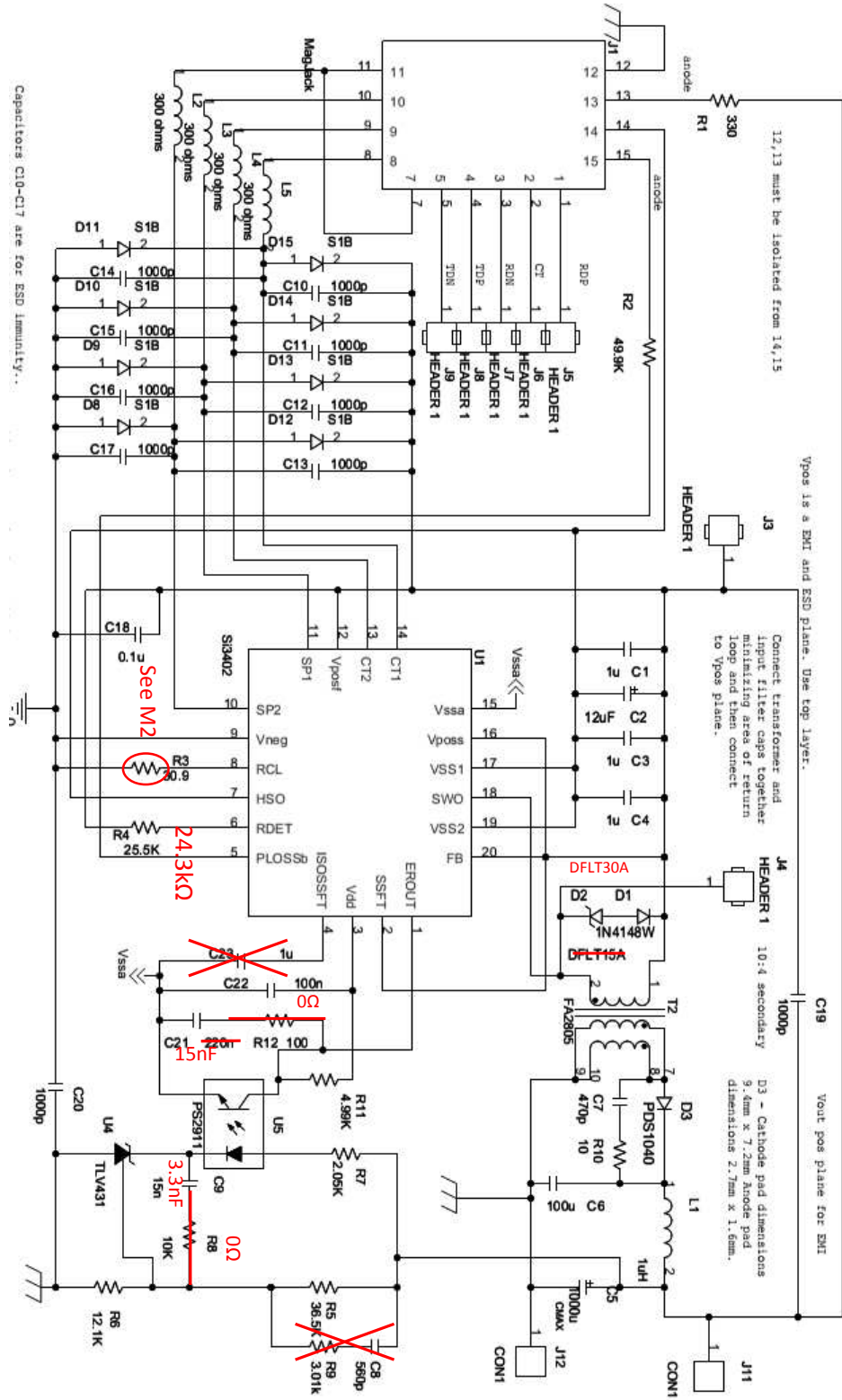

Si3402 (Buck, Non-Isolated) EVB Reference Design - 5V

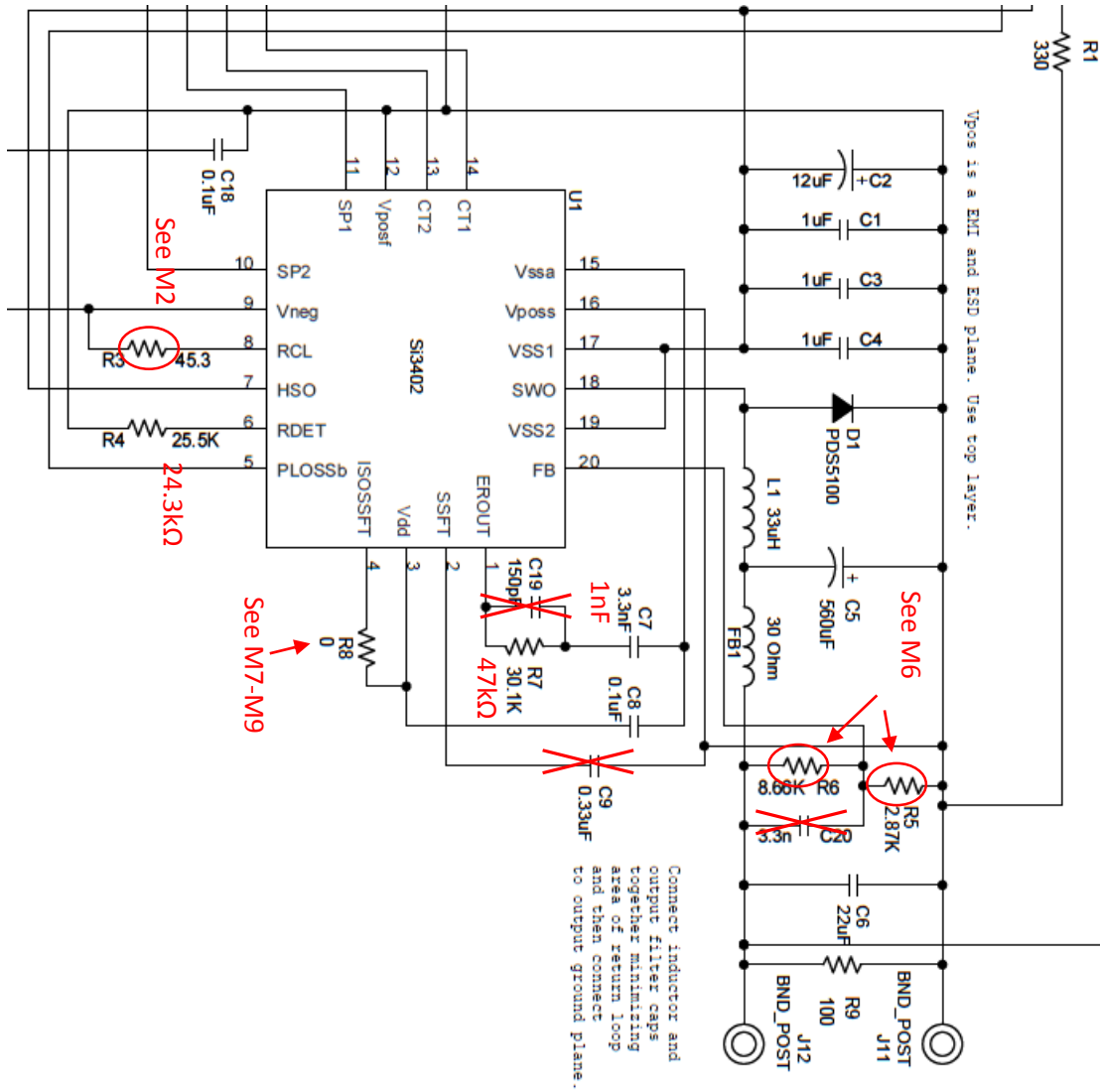



Revision Notes

26 August 2015:

- Added B5 indicating the Si3402-B-EN1 samples should be run only at room temperature
- Clarified Buck (Non-Isolated) case R7 to standard value 47k Ω and relaxed to 20% tolerance

28 October 2015:

- Previous version silicon errata resolved
- Several components in the change list updated
- Document renamed “**Si3402-B RevA3 Change List_<YYYYMMDD>**”

24 November 2015:

- M2 and M6 components updated
- Aligns with production Si3402-B-GM silicon

08 December 2015: (Version 0.3)

- Changed title of doc and name of file
- Clarified M7-M9 changes with regard to R8

21 March 2016: (Version 0.4)

- Updated M3, the 3.3V Isolated Flyback case.
 - Explanation: 3.3V Flyback compensation was updated to address a small overshoot condition under no-load conditions (3.66V is allowed, the overshoot was 3.73V). The problem is fixed with revised compensation with a resulting overshoot of about 3.5V.
 - If a no-load condition is unlikely, the customer may keep the original M3 change recommendation:
 - C8, R9 & C23 are not need—Do not populate them
 - C9=3.3nF, C21=15nF, R12=0 & R8=0 (place zero Ω resistors)
 - Replace D2 (DFLT15A) with DFLT30A