



Chipsmall Limited consists of a professional team with an average of over 10 year of expertise in the distribution of electronic components. Based in Hongkong, we have already established firm and mutual-benefit business relationships with customers from,Europe,America and south Asia,supplying obsolete and hard-to-find components to meet their specific needs.

With the principle of “Quality Parts,Customers Priority,Honest Operation,and Considerate Service”,our business mainly focus on the distribution of electronic components. Line cards we deal with include Microchip,ALPS,ROHM,Xilinx,Pulse,ON,Everlight and Freescale. Main products comprise IC,Modules,Potentiometer,IC Socket,Relay,Connector.Our parts cover such applications as commercial,industrial, and automotives areas.

We are looking forward to setting up business relationship with you and hope to provide you with the best service and solution. Let us make a better world for our industry!



## Contact us

Tel: +86-755-8981 8866 Fax: +86-755-8427 6832

Email & Skype: info@chipsmall.com Web: www.chipsmall.com

Address: A1208, Overseas Decoration Building, #122 Zhenhua RD., Futian, Shenzhen, China



---

## Si3460 EVALUATION BOARD USER'S GUIDE

---

### 1. Introduction

This document is intended to be used in conjunction with the Si3460 data sheet for designers interested in:

- An introduction to Power-over-Ethernet (PoE) and Power Sourcing Equipment (PSE) design considerations
- How the Si3460 PSE controller operates in the Si3460-EVB reference design
- Configuring and operating the Si3460-EVB

### 2. Overview of the Si3460 and Evaluation Board

The Si3460 is a single-port –48 V power management controller for IEEE 802.3af compliant Power Sourcing Equipment (PSE). The Si3460 operates directly from a 12 or 15 V isolated input supply and integrates a digital PWM-based dc-dc converter for generating the –48 V PSE output supply. The negative polarity on the PSE supply provides safety-extra-low-voltage (SELV) compatibility with telephony ports in the same system. The complete Si3460 reference design (i.e., the Si3460-EVB) also provides full IEEE-compliant classification and detection as well as a robust disconnect algorithm. Intelligent protection circuitry includes input under-voltage lockout (UVLO), current limiting, and output short-circuit protection.

The Si3460 is designed to operate completely independently of host processor control. A reset input and an optional LED status signal is provided to indicate the port status, including detect, power good and output fault event information for use within the host system.

The Si3460 is pin programmable to support:

- Endpoint and midspan applications, with support for either 10/100BASE-T or 10/100/1000BASE-T
- All four classification power levels specified by the IEEE 802.3 standard
- Classification-based current limiting
- Automatic or manual restart after various fault events are detected

### 3. Introduction to PoE

IEEE 802.3-2005 clause 33 (formerly IEEE 802.3af) is the standard for providing power to a remote Ethernet device on the same cable that is carrying data. The power is either carried common mode on one of the data pairs (for 10/100/1000BASE-T) or on the spare pairs for 10/100BASE-T only applications.

Figures 1 and 2 show the possible connections for the power. The connections shown in Figure 1 should be used for power injection in an Ethernet midspan, and the connections shown in Figure 2 can be used for either midspan or endpoint (switch) applications. Designed for use on the PSE side for providing power to a single Ethernet PD port, the Si3460 can be configured to operate in either midspan or endpoint applications. Although at this time the existing IEEE specification doesn't specifically allow or prohibit gigabit (10/100/1000BASE-T) midspans, in midspan mode, the Si3460-EVB is designed to operate in 10/100BASE-T mode, as the power is carried on the spare pairs. However, the Si3460 controller can also be designed into gigabit endpoints with the power connected to either the data or spare pairs.

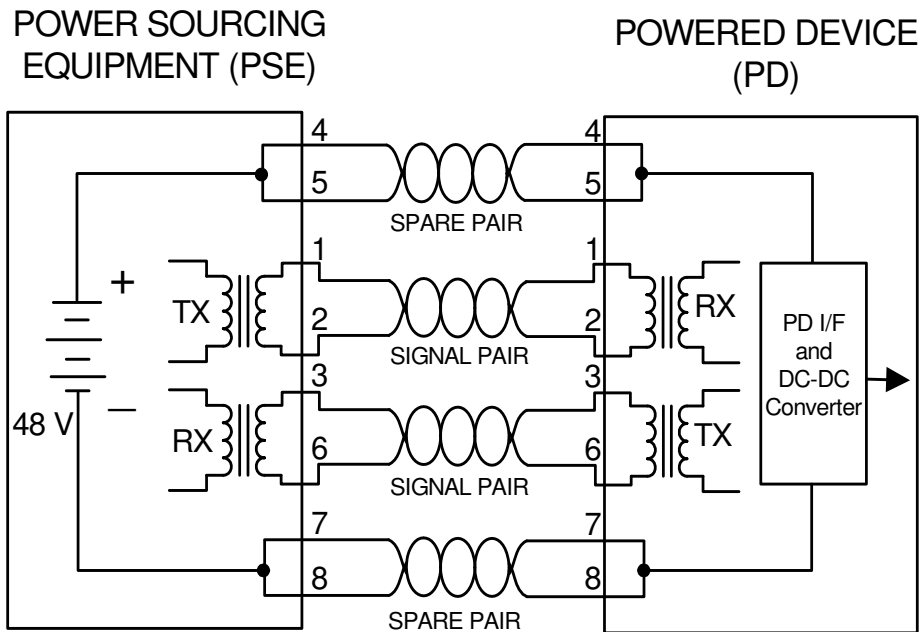

**Figure 1. Power Carried Over the Spare Pair (10/100BASE-T Applications Only)**

**Note:** This is the connection scheme implemented on the Si3460-EVB reference design.

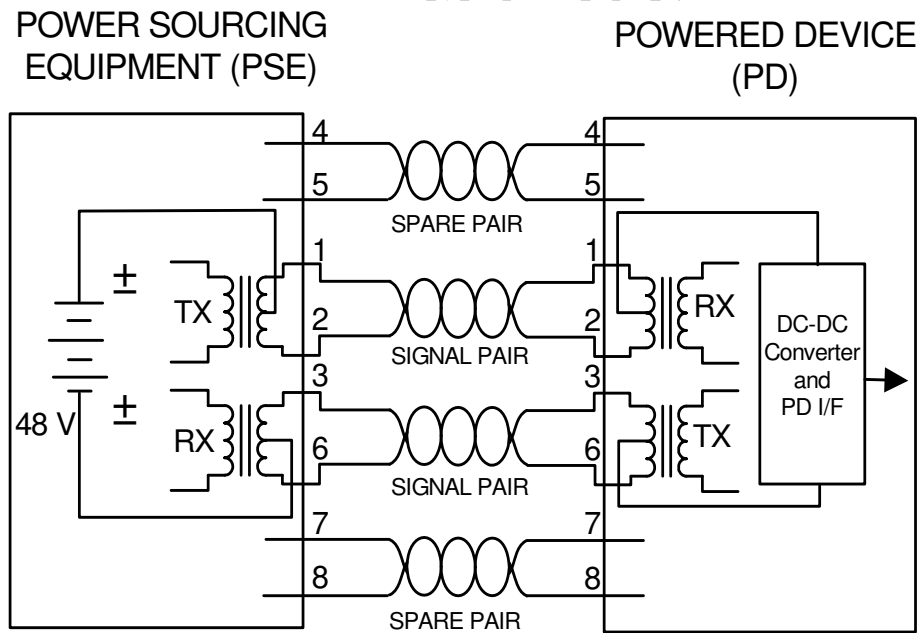

**Figure 2. Power Carried Over the Signal (Data) Pair**

## 4. PSE Detection, Classification, Power-Up, and Power Removal

The basic sequence for applying power is shown in Figure 3. Following is a description of the functions that must be performed in each phase.

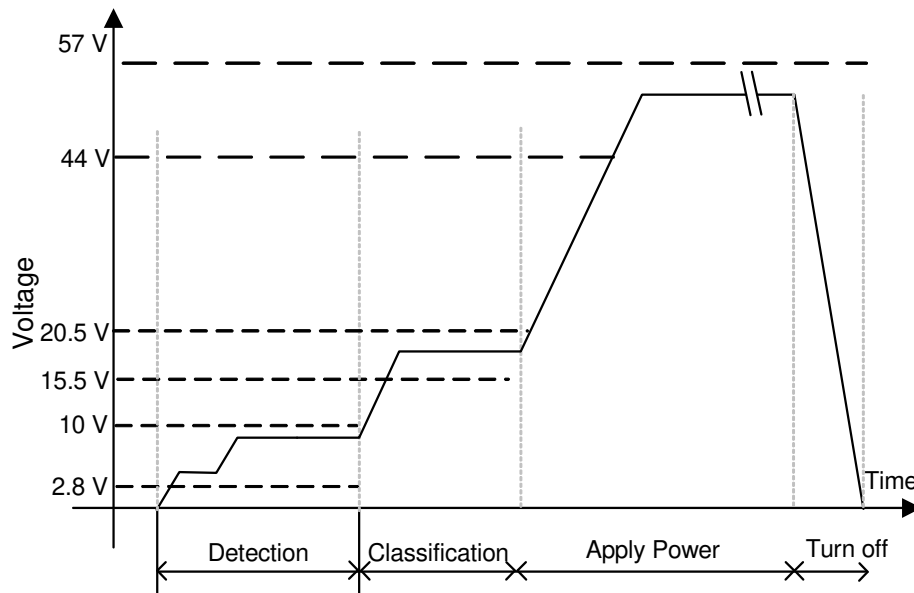

**Figure 3. Detection, Classification, Powerup, and Disconnect Sequence**

### 4.1. Detection

During the detection phase, the PSE probes with limited current and voltage to determine if a 25 k $\Omega$  signature is present. A valid PD must present between 23.75 and 26.25 k $\Omega$  in the range of 2.7 to 10.1 V, with an offset (due to the bridge diodes) of up to 1.9 V, and a parallel capacitance of between 0.05 and 0.12  $\mu$ F. An IEEE-compliant PSE probes 2.8 and 10 V, with at least a 1 V step and current limit of <5 mA. The PSE must accept signatures in the range of 19–26.5 k $\Omega$  with capacitance of up to 0.15  $\mu$ F and must reject resistance <15 k $\Omega$  or >33 k $\Omega$  as well as capacitive signatures >10  $\mu$ F.

The strict limits on the detection phase ensure that non PoE enabled devices are not inadvertently powered. For endpoint applications, detection must be completed within 500 ms of applying a valid signature. When configured as a midspan there is a possibility that the PSE circuit will compete with an endpoint PSE, and, as required by the IEEE specifications, the Si3460 is therefore required to wait at least 2 seconds after an unsuccessful detection cycle to repeat the detection process.



## 4.2. Classification

Classification is optional and is performed by applying between 15.5 and 20.5 V to the PD and measuring the current. The maximum power level that can be drawn by the PD is determined according the following table.

**Table 1. Classification Levels**

Classification Level	Minimum PSE Power Level	Current Measured
Class 0	15.4 W	<5 mA
Class 1	4 W	8–13 mA
Class 2	7 W	16–21 mA
Class 3	15.4 W	25–31 mA
Class 4	15.4 W	35–45 mA

Currents not falling in these ranges maybe be treated as the higher or lower classification level. Currents above 45 mA may be treated as class level 0 or 4, which is 15.4 W in either case.

## 4.3. Power-Up

After the optional classification step, power is applied. Per the IEEE specification, the PSE must supply between 44 and 57 V to the PD. For longer durations above 50 ms the power may be removed if the maximum power level of either 4, 7, or 15.4 W is exceeded. If the current exceeds 400 mA, the power must be removed in 75 ms. For short-circuit protection, output power is removed immediately if the output current exceeds 800 mA or the output voltage drops below 30 V. If power is removed due to an overload condition, detection must not be attempted again for at least 2 s.

## 4.4. Disconnect (Power Removal)

The Si3460 supports a robust disconnect algorithm to avoid false disconnection. Removal of a PD can be sensed by determining that the dc current is less than 5 mA for between 300 and 400 ms. If the current then exceeds 10 mA for at least 60 ms, the power must not be removed, and the 300–400 ms timer restarts.

## 5. The Si3460 PSE Controller

In addition to providing a complete dc-dc controller to generate the PSE output supply, the Si3460 is a fully IEEE compliant PSE power management controller. The Si3460 is specifically designed and configured to work with an applications circuit (Si3460-EVB) that together implement a single port PSE solution for either midspans or endpoints.

Referring to the detailed evaluation board schematics in Section “8. Si3460-EVB Schematics and PCB Layout”, the overall functionality is described for each operating state of the Si3460 as follows:

### 5.1. Initialization and Operating Mode Configuration

The Si3460 is initialized at power up, or whenever pin 8 ( $\overline{RST}$ ) is held low and then allowed to transition high. Upon reset ( $\overline{RST}$  asserted), the voltage at the STATUS pin (as determined by resistors R28 and R30) is sensed to determine the operating mode of the Si3460. The detection process begins immediately after initialization.

Any combination of the following three operating modes can be set by the R28 and R30 resistor pair, as indicated below:

- Classification level: sets what maximum power level the Si3460 will support.
- Endpoint or midspan mode: controls the backoff timing per the IEEE specifications.
- Restart action on fault or overload: determines whether or not the Si3460 will automatically restart after 2 s when a fault or overload condition (e.g., input UVLO, output short-circuit event, classification power level exceeded) is detected, or wait to restart until the  $\overline{RST}$  pin is asserted.

**Table 2. Operating Modes**

Nominal Status Pin Voltage	Operating Mode				
	R28, R30	Power Level Supported (W)	Classes Supported	Endpoint/ Midspan	Restart Action on Fault or Overload Event
Pin voltage at VEE	2 k $\Omega$ , NP	15.4	All class levels	Endpoint	Auto restart after 2 s
3.0 V	2.21 k $\Omega$ , 22.1 k $\Omega$	7.0	Class 1 or 2		
2.75 V	2.37 k $\Omega$ , 11.8 k $\Omega$	4.0	Class 1		
2.5 V	2.61 k $\Omega$ , 8.06 k $\Omega$	15.4	All class levels		
2.25 V	2.94 k $\Omega$ , 6.19 k $\Omega$	7.0	Class 1 or 2		
2.0 V	3.32 k $\Omega$ , 4.99 k $\Omega$	4.0	Class 1		
1.75 V	3.83 k $\Omega$ , 4.22 k $\Omega$	4.0	Class 1	Midspan	Restart on $\overline{RST}$ low or when open circuit detected
1.5 V	4.42 k $\Omega$ , 3.57 k $\Omega$	7.0	Class 1 or 2		
1.25 V	5.36 k $\Omega$ , 3.16 k $\Omega$	15.4	All class levels		
1.0 V	6.81 k $\Omega$ , 2.80 k $\Omega$	4.0	Class 1		
0.5 V	14 k $\Omega$ , 2.26 k $\Omega$	7.0	Class 1 or 2		
< 0.25 V	NP, 2 k $\Omega$	15.4	All class levels		

# Si3460-EVB

## 5.2. CTRL1 and CTRL2

These two pins are the output of two 96 kHz 8-bit pulse width modulators. The output of these pins is averaged using R15, R29, and C5 to produce a dc level across C5 that is controllable with 16-bit resolution. This dc voltage is used to control both the detection process and the pulse width modulator for the dc-dc converter.

## 5.3. Detection

During the detection phase, the pass transistor M2 is held off by driving the GATE pin high. The 250 kHz clock for the PWM circuit is held low, forcing the switcher FET M1 off.

In the detect state, the output voltage is determined by the output of U18A feeding the resistive bridge R1, R2, and R3. The PD at the other end of a cable forms the fourth leg of the bridge. The return path to Vee is through D8 and L1. The bridge null is read through amplifier U18B, which is fed to the Si3460 pin DETA.

The output of U18A is controlled by the CTRL1 and CTRL2 pins as noted earlier. For most of the detection cycle, the CTRL pins are held high which forces U18A low, producing no output. The bridge voltage is varied to force IEEE compliant detection voltages of approximately 4.5 and 7.5 V across the bridge with 20 ms delay and robust three-point detection algorithm at 4.5, 7.5, and back to 4.5 V. To robustly insure that the PD has a valid resistive signature, the bridge null is checked as the voltage increases and then checked again as the voltage decreases. Relevant waveforms are shown in Figure 4 and Figure 5 on page 11.

## 5.4. PWM

In order to apply power to the load, M2 is turned on by driving the Si3460's GATE pin high. At the same time, the PWM circuitry is enabled by turning on the 250 kHz clock (250 kHz pin). The 250 kHz square wave is converted to a triangular shape by the filter R14 and C6. The dc level set by CTRL1 and CTRL2 is used to control the PWM comparator U19B that drives the switcher FET through gate driver U3.

The output voltage is sensed through resistor divider R43 and R44, and the output current is sensed through resistor R4. The Si3460 integrates an A/D that measures these quantities and varies the CTRL1 and CTRL2 duty cycle to regulate the output current and voltage as desired.

## 5.5. Classification

For classification, M2 is turned on and the PWM is enabled. The Si3460 is programmed to perform classification at 18 V output voltage, with a current limit of between 50 and 100 mA. Classification is performed after allowing 20 ms of settling time.

Since the Si3460-EVB is designed for a single port PSE application, the classification information is only used to determine if the load is in the range that is supported, according to the mode of the Si3460 determined at power up (refer to STATUS pin in Section "5.1. Initialization and Operating Mode Configuration").

**Table 3. Classification Levels**

Classification Mode	PSE Minimum Output Power	Action Performed	Overload Current Threshold $I_{CUT}$ (Max)	Overload Current Limit $I_{LIM}$ (Max)
Full power	15.4 W	Always apply full power	400 mA	450 mA
Class 1 only	4 W	Only apply power if the current is between 8 and 13 mA (class 1)	98 mA	450 mA
Class 1 or Class 2	7 W	Only apply full power if the current is between 8 and 21 mA (class 1 or class 2)	180 mA	450 mA

If the measured classification level is not in the supported range, an error is declared and the Si3460 will either time out and retry and wait for a reset as determined by the power up mode of operation. Relevant waveforms are shown in Figure 5 on page 11 and Figure 6 on page 12. If the class level is in the supported range, the Si3460 proceeds to powerup.

## 5.6. Power-Up

After successful classification, the Si3460 is configured to produce a nominal –50 V output voltage. The overload current limits are set based on the classification voltage on the STATUS pin at powerup. Refer to Table 1 of the Si3460 data sheet for more information.

For output current durations lasting longer than 60 ms, the power is removed if the maximum power level of either 4, 7, or 15.4 W is exceeded by approximately 10%, as determined by the operating mode detected at start up (refer to Section “5.1. Initialization and Operating Mode Configuration”). In the event of an output short circuit, the Si3460 will immediately disconnect so as to prevent shorting the input supply through D8 and L1.

The Si3460 can be configured to operate in a mode where it will automatically retry detection and power up after an overload. Alternatively, the Si3460 can be programmed to signal an error condition has occurred, in which case the user must assert RST (e.g., by pushing the reset switch on the Si3460-EVB) to start a new detection and power up cycle.

As set by the initial voltage on the STATUS pin at powerup, the Si3460 will then automatically resume the detection process for "automatic restart configuration" unless the Si3460 is configured in a "restart after a RESET condition" mode and a fault condition is detected; in that case, the LED will flash rapidly, and the detection process will automatically start again after 2.2 seconds. Power will not be provided until an open-circuit condition is detected. Once the Si3460-EVB detects an open-circuit condition (normally by removing the Ethernet cable from the Si3460-EVB's RJ-45 jack labeled "To PD"), the detection process begins, the status LED blinks at the rate of 3 times per second, and the Si3460 is then allowed to go into classification and powerup mode if a valid PD signature resistance is detected. The relevant waveform is shown in Figure 6 on page 12.

## 5.7. Disconnect (Power Removal)

The Si3460 supports a robust disconnect algorithm. If the current drops below 5 mA for between 300 and 400 ms, the power is removed. If the output current then exceeds 10 mA for at least 60 ms, the power is not removed. The Si3460 will continue to provide power unless a disconnect or overload condition is sensed. The only other way to force the Si3460 to disconnect power is by doing a reset. The relevant waveform is shown in Figure 7 on page 12.

## 5.8. Current Limit Control

The Si3460's overcurrent trip point is determined by the output power set during the classification stage power granting process. If the output current exceeds the threshold, a timer counts up towards a time-out of 60 ms. If the current drops below the set threshold, the timer counts down towards zero at 1/16th the rate. If the timer reaches 60 ms, an overcurrent fault is declared, and the channel is shut down by turning off the dc-dc converter clock and then turning off the FET M1. After an overcurrent fault event, the LED will flash rapidly.

As set by the initial voltage on the STATUS pin at powerup, the Si3460 will then automatically resume the detection process for "automatic restart configuration" unless the Si3460 is configured in a "restart after a RESET condition" mode and a fault condition is detected; in that case, the LED will flash rapidly, and the detection process will automatically start again after 2.2 seconds. Power will not be provided until an open-circuit condition is detected. Once the Si3460-EVB detects an open-circuit condition (normally by removing the Ethernet cable from the Si3460-EVB's RJ-45 jack labeled "To PD"), the detection process begins, the status LED blinks at the rate of 3 times per second, and the Si3460 is then allowed to go into classification and powerup mode if a valid PD signature resistance is detected.

## 5.9. UVLO

The Si3460-EVB reference design is optimized for 12 to 15 V nominal input voltages\* (11 V minimum to 16 V maximum). If the input voltage drops below 10 V in detection mode or if the output voltage drops below 10 V in classification or power up mode, a UVLO condition is declared which generates the error condition (LED flashing rapidly). An under-voltage event is a fault condition which is reported through the status LED as a rapid blinking of 10 flashes per second. The UVLO condition is continuously monitored in all operating states.

**\*Note:** Some MOSFET gate drivers operate at a maximum supply voltage of 14 V (for example, TPS2828). In that case, the input voltage must be limited to a maximum of 12 V.



## 5.10. Status LED Function

During the normal detection sequence, the STATUS LED flashes at approximately 3 times per second as the detection process continues. After successful power up, the LED glows continuously. If there is an error condition (i.e., class level is beyond programmed value, or a fault or over current condition has been detected), the LED flashes rapidly at 10 times per second). This occurs for two seconds for normal error delay and, in the case of the "restart after a RESET condition," the LED will flash rapidly, and the detection process will automatically start again after 2.2 s and power will not be provided until an open circuit condition is detected. Once the Si3460-EVB detects an open circuit condition, the LED blinks at 3 times per second.

If the Powered Device (PD) is disconnected so that a disconnect event occurs, the LED will start flashing at 3 times per second once the detect process resumes.

Not Recommended for New Designs.  
Please Consider Si3462 for New Designs.

## 6. Design and Layout Considerations

### 6.1. General Recommendations

The Si3460-EVB schematic and layout are intended to be used as a reference for all customer designs. The Si3460-EVB has been tested by the University of New Hampshire Interoperability Lab (UNH IoL) to comply with the relevant IEEE 802.3 Clause 33 specifications. UNH test reports can be downloaded from [www.silabs.com/PoE](http://www.silabs.com/PoE). Since the Si3460's performance in an application depends on external components and PCB layout, customers are ultimately responsible for validating their design's conformance to all relevant industry, safety, and customer-specific requirements. For applications support, contact [PoEinfo@silabs.com](mailto:PoEinfo@silabs.com).

### 6.2. Isolation

The IEEE 802.3 specification requires the PSE output power to be isolated from earth ground\*. To accomplish this, the input power source must be isolated from earth ground. Also, do not connect the Si3460's ground connection (pin #11) to earth ground, as this pin serves a circuit reference point only in the Si3460-EVB.

**\*Note:** If the input power supply is referenced to earth ground, and if one of the output pads is connected to ground, it can create a high-current fault condition that will not be protected.

### 6.3. SELV-Compliant Output Voltage

Since the output of the Si3460-EVB reference design is designed to be less than 57 Vdc under all conditions, it is considered a SELV circuit.

The Si3460-EVB is designed to produce a negative output voltage with respect to the input voltage. The reason this is done is because the Si3460 will often be used in applications and environments where a standard telephone circuit or SLIC, such as the Si3210/15/32/33, will be powered from the same 12 to 15 V isolated input power supply. Conventionally, these circuits produce large negative operating voltages. Since the Si3460-EVB reference design is also designed to produce negative voltages, the Si3460-EVB implementation eliminates the possibility of a hazardous voltage difference between a SLIC output and the Si3460-EVB's PSE output.

### 6.4. Surge Protection

The Si3460-EVB applications design includes a clamp diode, D12, to protect against the 50  $\mu$ s intra-building lightning surges, as specified in IEEE 802.3. Additional protection, such as a 1 A fuse in the output circuit, may be required for applications in which the Ethernet cabling is not intra-building.

### 6.5. EMI and EMC

The Si3460-EVB applications solution is designed to be compliant with FCC Class B (CISPR22) for radiated emissions, as well as FCC Part 15 (EN55022) for conducted emissions. The PCB layout of the Si3460-EVB should be closely followed to prevent EMI and EMC issues.

The keys to robust EMI and EMC performance are:

- Keep the current loops in the switcher circuit small-diameter.
- Lay out the current loop when the FET is on similarly to the current loop when the FET is off.
- Connect filter caps to the power circuitry and not to reference planes.
- For better EMI performance, use shielded inductors for L1 and L4.

### 6.6. Thermal Considerations

**Inductor L1:** For improved thermal performance, Silicon Laboratories strongly recommends using a shielded inductor for L1. The recommended shielded inductor is available from Coilcraft: MSS1278T-154. Please refer to: <http://www.coilcraft.com/pdfs/mss1278t.pdf>.

## 6.7. R43 and R47

Resistors R43 and R47 together dissipate about 1 W of power during normal operation. Resistors R43, R47, and R44 (127  $\Omega$ ) are chosen based on the IEEE minimum disconnect current specifications and to ensure good transient response for sudden load changes. To help ensure that heat dissipated by R43 and R47 does not unduly contribute to the heating of the PCB, it is recommended to move these resistors away from other heat-dissipating components, such as switching FET M1, inductor L1, and switching diode D8.

Not Recommended for New Designs.  
Please Consider Si3462 for New Designs.

## 7. Output Voltage and Load Current Waveforms

Figures 4 through 9 show output voltage and load current waveforms during startup and fault conditions. See the Si3460-EVB schematics in Figures 10 and 11.

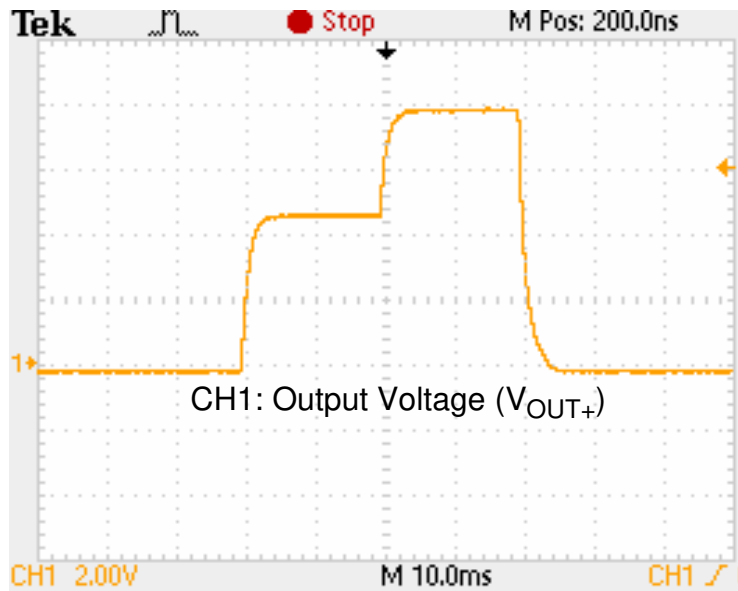

Figure 4. Waveform Showing Detection Pulse into Open-Circuit

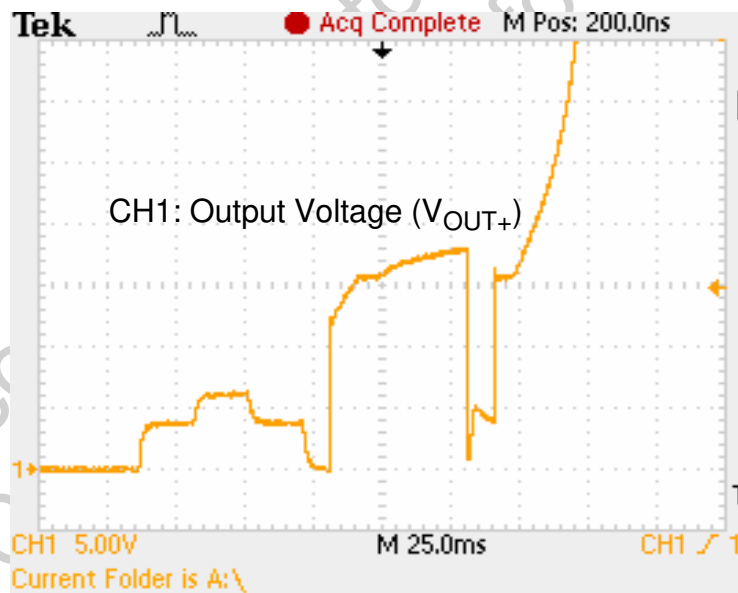

Figure 5. Output Voltage Waveform Showing both Detection and Classification Pulse during Startup

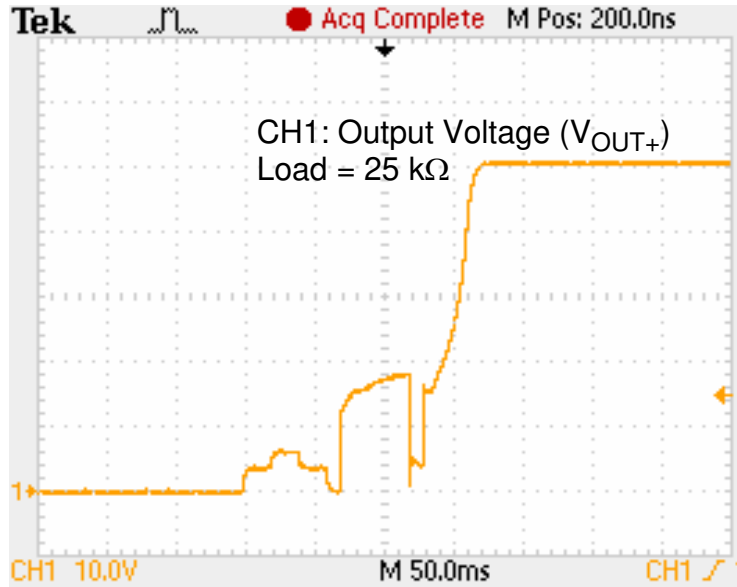

Figure 6. Waveforms Showing Successful Powerup

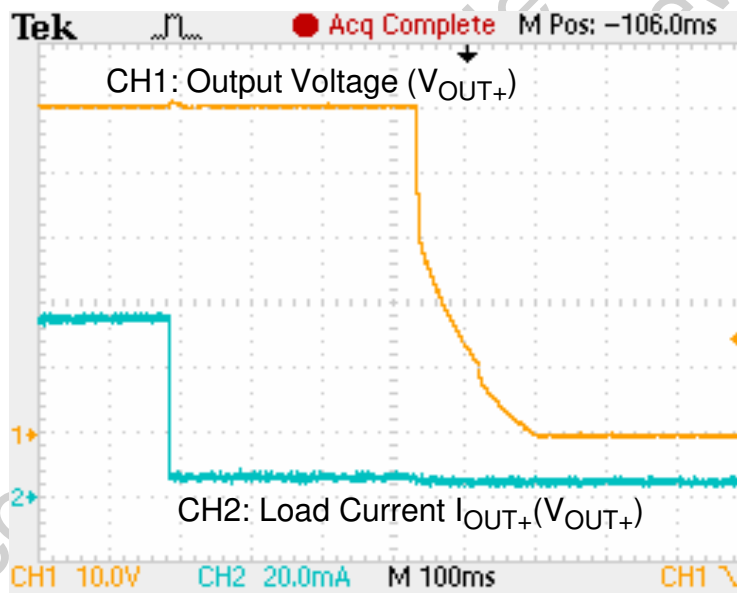

Figure 7. Disconnect Waveforms with Time Delay of 350 ms

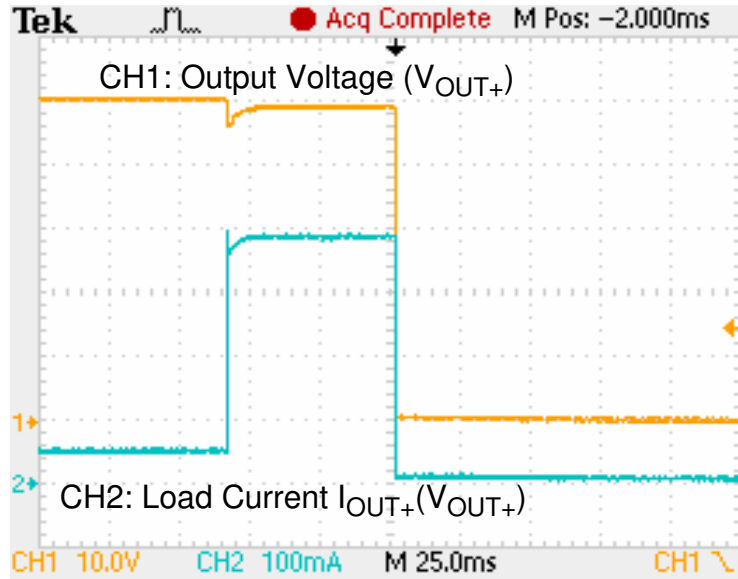

Figure 8. Waveform Showing Overcurrent Disconnect Delay Time of 60 ms

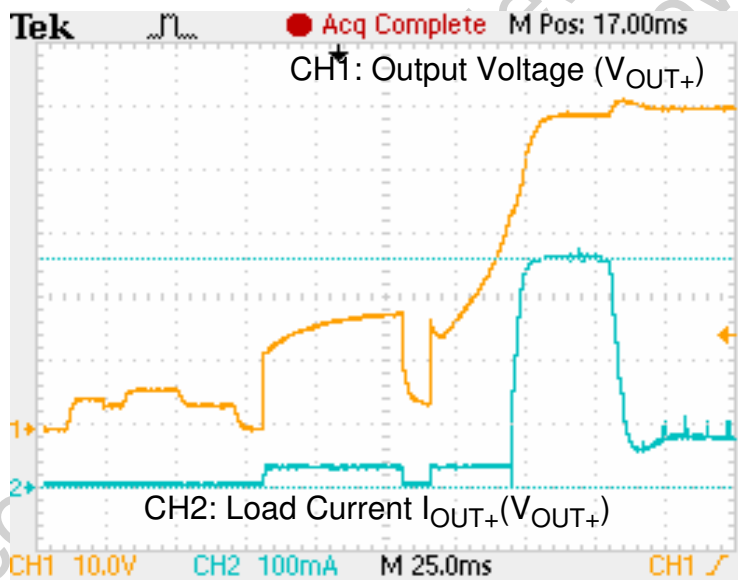

Figure 9. Overcurrent during Startup with 400 mA Overload



# Si3460-EVB

## 8. Si3460-EVB Schematics and PCB Layout

Full schematics and layout information are provided in the following sections. To ensure you are using the latest schematic and PCB layout database revisions, download the following zip file from the Silicon Laboratories Si3460 documentation page:

<http://www.silabs.com/products/power/poe/Pages/PowerSourcingEquipment.aspx>

### 8.1. Schematics

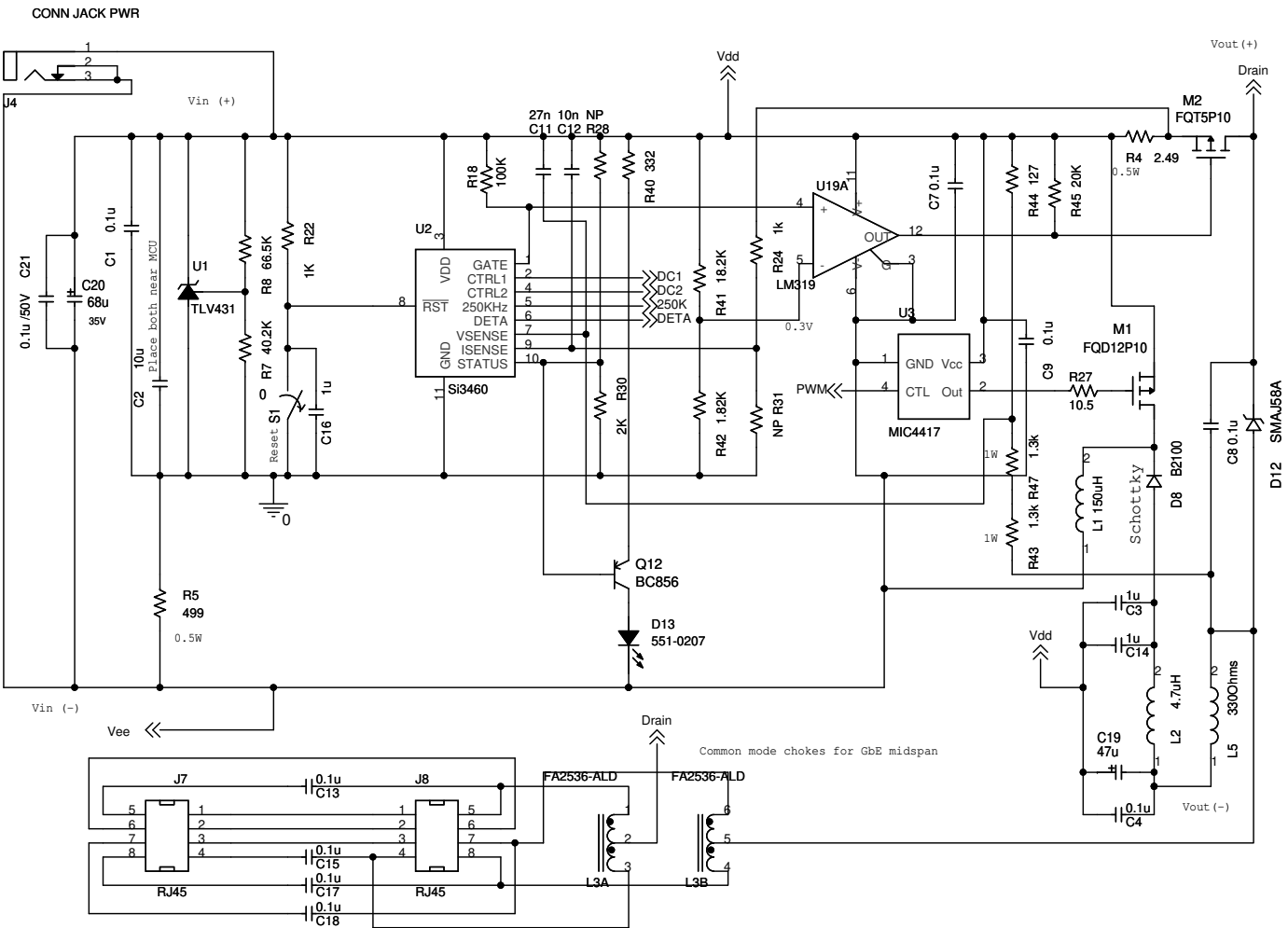

Figure 10. Si3460 and Power Circuit

Please Not Re

Rev. 1.2

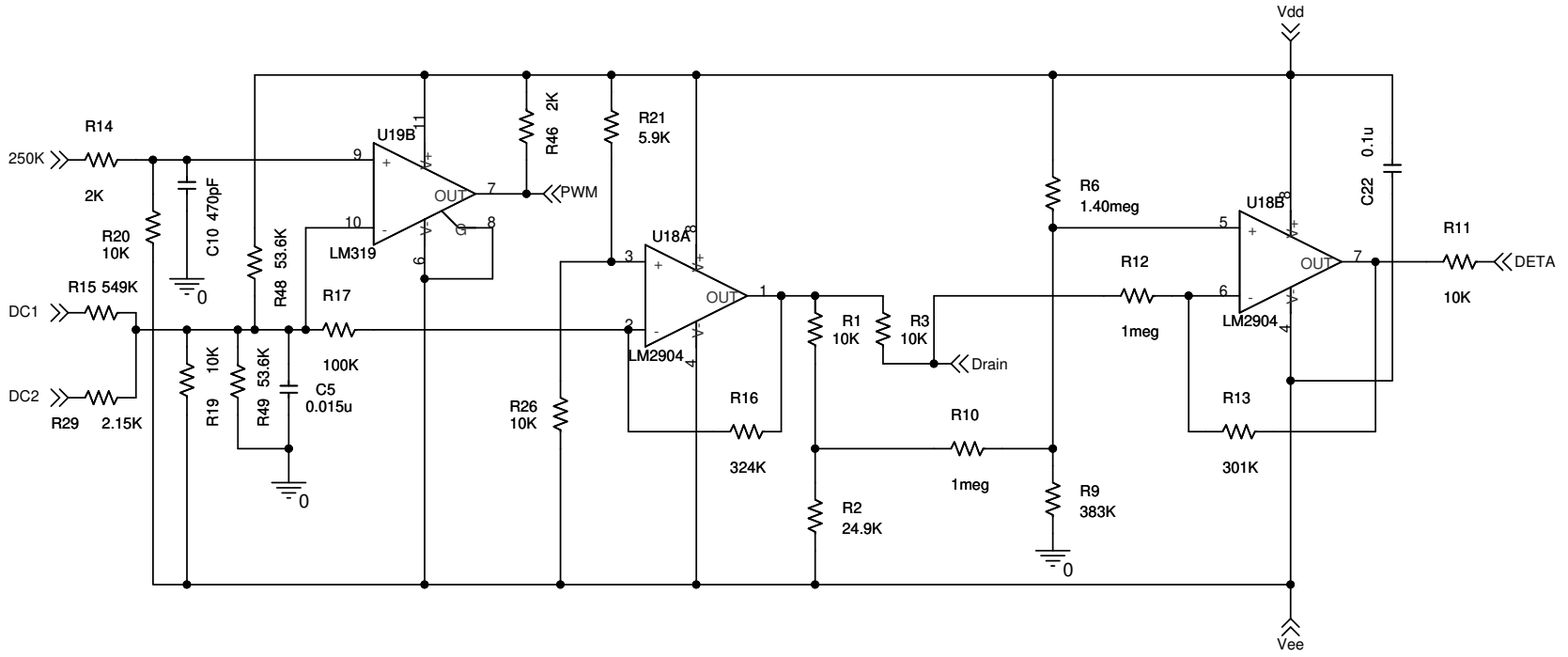

Figure 11. Detection and PWM Circuit

ew Designs.  
esigns.

# Si3460-EVB

## 8.2. PCB Layout

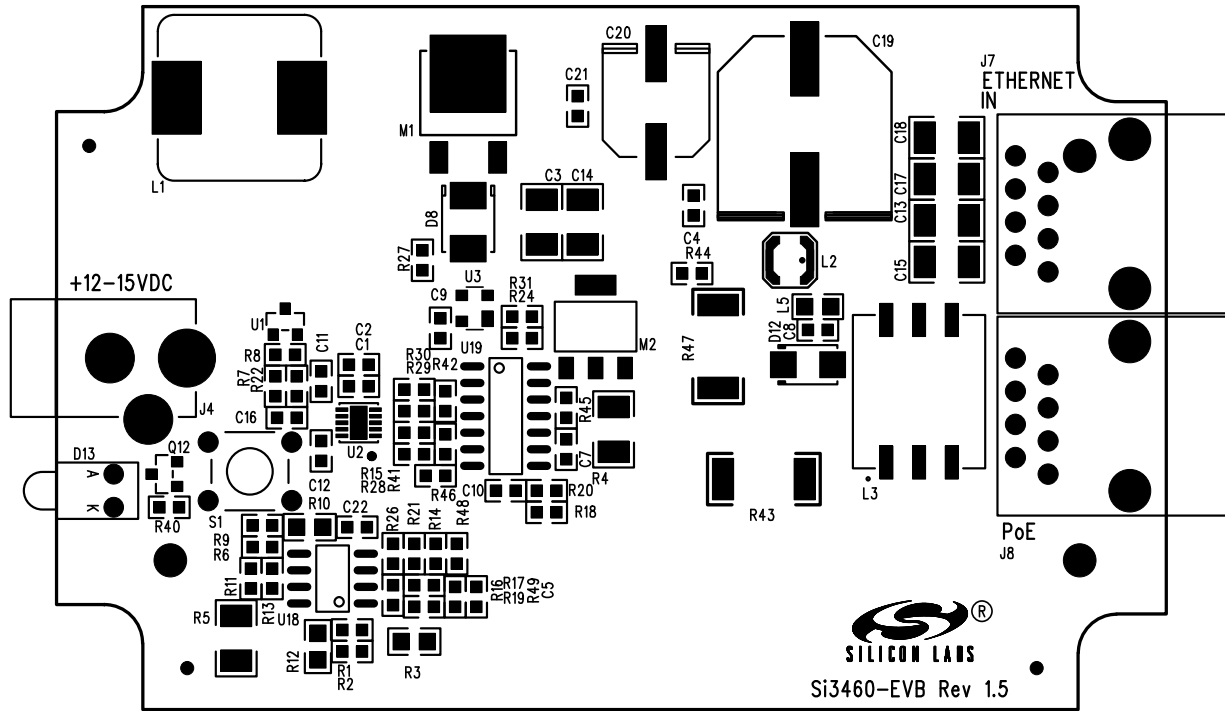

Figure 12. Top Side Component Placement

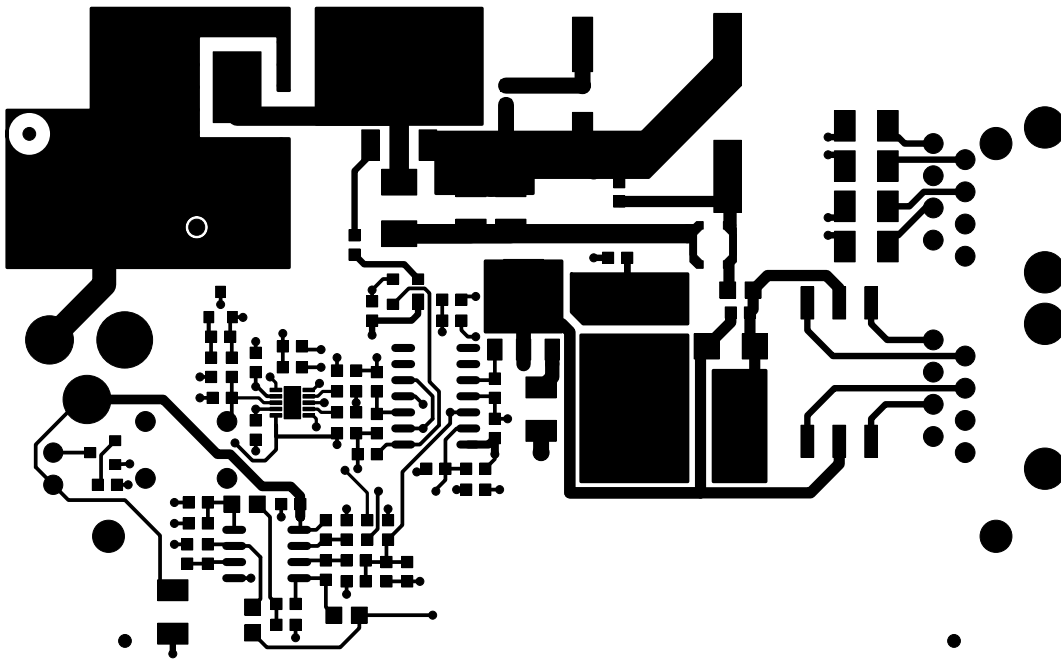

Figure 13. Top Side Interconnect

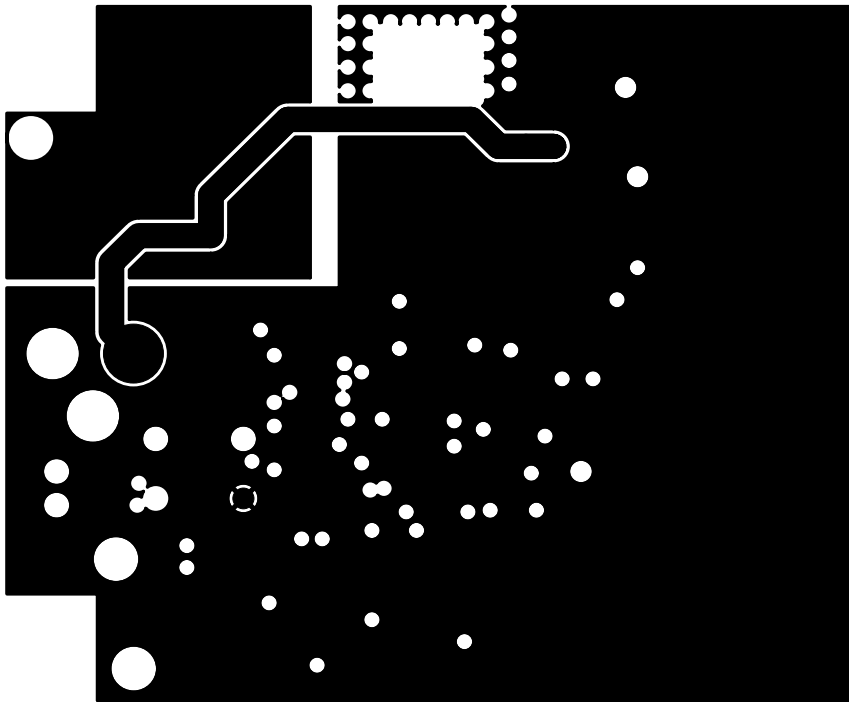

Figure 14. Si3460 Ground Plane

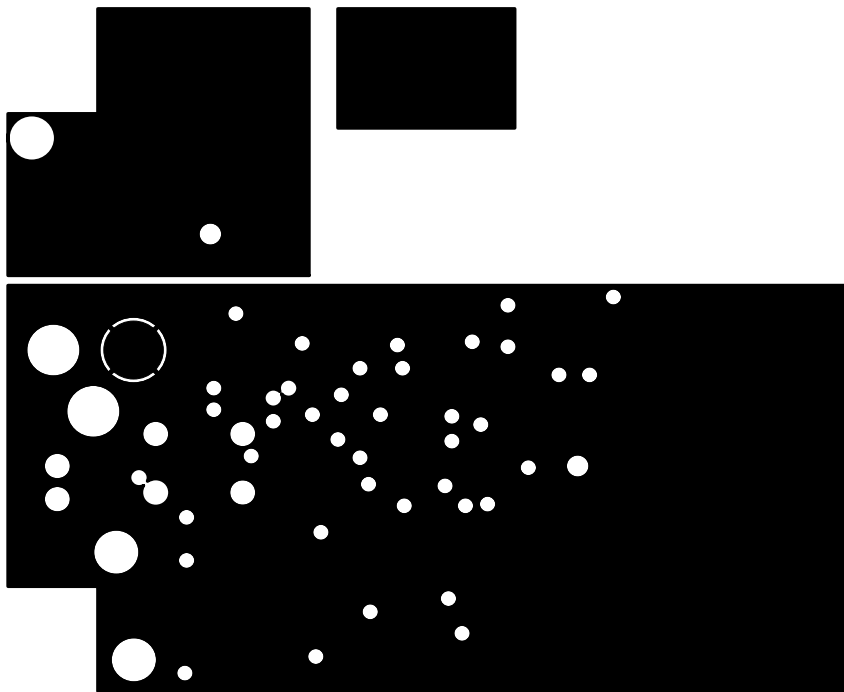

Figure 15. Si3460 Power Plane

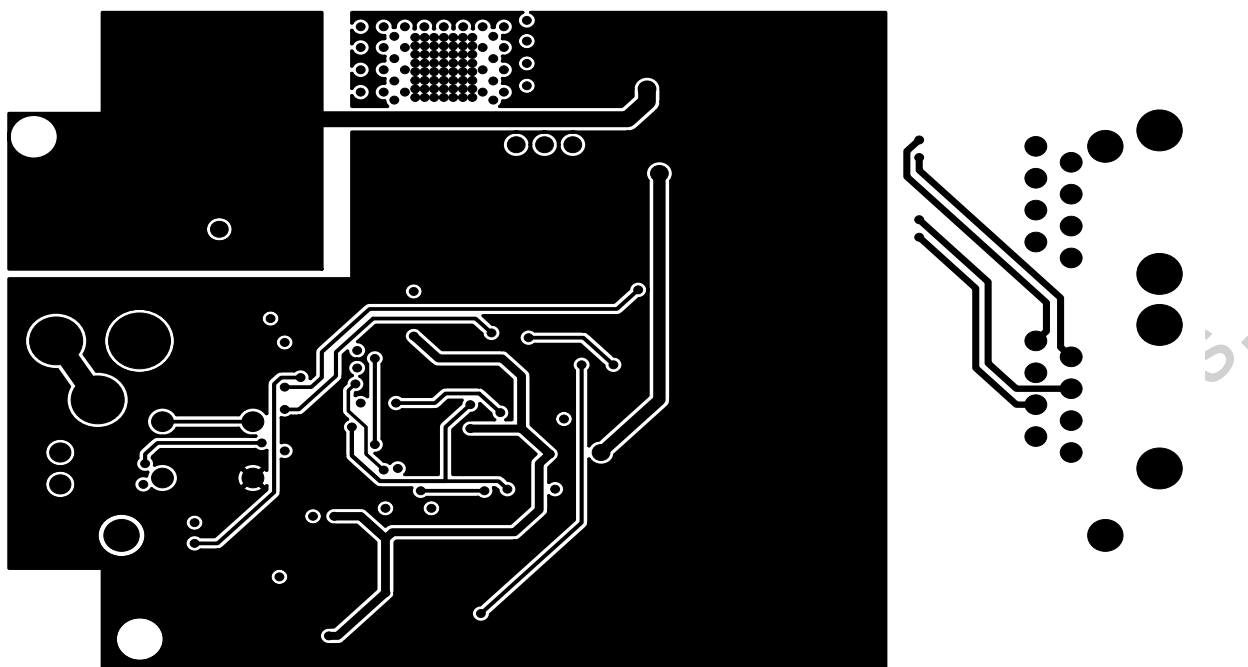

Figure 16. Bottom Side Interconnect

Not Recommended for New Designs  
Please Consider Si3462 for New Designs

## 9. BOM Component Considerations

See Section “10. Bill of Materials”.

To achieve optimal performance and full specification compliance, Silicon Labs strongly encourages the use of the components and vendor part numbers listed in the BOM. If alternate components must be substituted, please note the following recommendations for components in the power section.

- The digital control loop for the dc-dc converter has been optimized for stability with the ~41  $\mu\text{F}$  total output capacitance and 150  $\mu\text{H}$  shielded inductor (L1). Capacitors C19, C20, C3, and C14 must provide suitably low ESR for ripple considerations.
- Diode D8 must have suitable high voltage and low recovery time. A Schottky diode works well.
- Diode D12 must not clamp at 57 V and must clamp to <100 V under worst case surge conditions.
- Transistors M1 and M2 are sized for overall efficiency. The larger FQD8P10 can be used in both places, if desired.
- The FET gate driver should be capable of sinking and sourcing approximately 2 A.
- Heat dissipating components must be separated from each other and moved away from components that are heat-sensitive. An example would be moving heat-dissipating inductor L1 so that it is kept away from electrolytic capacitors C19 and C20.
- For better electromagnetic interference (EMI) performance, high current carrying inductors must be of the shielded type.

Other component considerations:

- Resistors R23, R25 and the programming header J6 are used for development purposes only. The Si3460 is not user programmable, and it is not recommended these components be included in actual layouts (short R23 and R25, and remove J6).



# Si3460-EVB

## 10. Bill of Materials

Table 4. Si3460-EVB Bill of Materials

Qty	Ref	Value	Rating	Tol	Dielectric	PCB Footprint	Mfr Part #	Mfr
<b>External PSE BOM (R-BOM)</b>								
4	C1,C7, C8, C21, C22	0.1 $\mu$ F	100 V	10%	X7R	603	C0603X7R101104K	Venkel or equiv.
1	C16	1 $\mu$ F	10 V	10%	X7R	603	C0603X7R100106K	Venkel or equiv.
1	C2	10 $\mu$ F	6.3 V	10%	X5R	603	C0603X5R6R3106K	Venkel or equiv. or Murata
1	C11	27 nF	100 V	10%	X7R	603	C0603X7R101273K	Venkel or equiv.
1	C12	10 nF	100 V	10%	X7R	603	C0603X7R101103K	Venkel or equiv.
1	C20	68 $\mu$ F	25 V	20%	Al Elec	10mm	EEEF1E680P	Panasonic or equiv.
1	D12	SMAJ58A	58 V			SMA		Diodes Inc or equiv.
1	M2	FQT5P10	100 V			SOT-223	FQT5P10	Diodes Inc or equiv.
1	Q12	BC856				SOT23	BC856A	Diodes Inc or equiv.
3	R1,R11, R26	10 k $\Omega$		1%		RC0603	CR0603-10W-1002F	Venkel or equiv.
1	R2	24.9 k $\Omega$		1%		RC0603	CR0603-10W-1002F	Venkel or equiv.
1	R3	10 k $\Omega$		1%		RC0805	CR0805-8W-1002F	Venkel or equiv.
1	R4	2.49 $\Omega$		1%		RC1210-2W	CR1210-2W-2R49F	Venkel or equiv.
1	R5	499 $\Omega$		1%		RC1210-2W	CR1210-2W-4990F	Venkel or equiv.
1	R6	1.40 M $\Omega$		1%		RC0603	CR0603-10W-1404F	Venkel or equiv.
1	R7	40.2 k $\Omega$		1%		RC0603	CR0603-10W-4022F	Venkel or equiv.
1	R8	66.5 k $\Omega$		1%		RC0603	CR0603-10W-6652F	Venkel or equiv.
1	R9	383 k $\Omega$		1%		RC0603	CR0603-10W-3833F	Venkel or equiv.
2	R10,R12	1 M $\Omega$		1%		RC0805	CR0805-10W-1004F	Venkel or equiv.
2	R13	301 k $\Omega$		1%		RC0603	CR0603-10W-3013F	Venkel or equiv.
1	R31	NP		1%		RC0603	NP	Venkel or equiv.
1	R16	324 k $\Omega$		1%		RC0603	CR0603-10W-3243F	Venkel or equiv.
2	R17,R18	100 k $\Omega$		1%		RC0603	CR0603-10W-1003F	Venkel or equiv.
1	R21	5.90 k $\Omega$		1%		RC0603	CR0603-10W-5901F	Venkel or equiv.
0	R28	NP - see table		1%		RC0603	See table	Venkel or equiv.

Table 4. Si3460-EVB Bill of Materials (Continued)

Qty	Ref	Value	Rating	Tol	Dielectric	PCB Footprint	Mfr Part #	Mfr
1	R30	2 k $\Omega$ - see table		1%		RC0603	CR0603-10W-2001F	Venkel or equiv.
2	R22,R24	1 k $\Omega$		1%		RC0603	CR0603-10W-1001F	Venkel or equiv.
1	R40	332 $\Omega$		1%		RC0603	CR0603-10W-3320F	Venkel or equiv.
1	R44	127 $\Omega$		1%		RC0603	CR0603-10W-1270F	Venkel or equiv.
1	R41	18.2 k $\Omega$		1%		RC0603	CR0603-10W-1822F	Venkel or equiv.
1	R42	1.82 k $\Omega$		1%		RC0603	CR0603-10W-1821F	Venkel or equiv.
1	R45	20 k $\Omega$ K		1%		RC0603	CR0603-10W-2002F	Venkel or equiv.
2	R48,R49	53.6 k $\Omega$		1%		RC0603	CR0603-10W-5362F	Venkel or equiv.
1	U1	TLV431				SOT23	TLV431	On Semi or equiv.
1	U18	LM2904				SO8	LM2904	On, Fairchild or equiv.
<b>Step-Up DC/DC Converter (R-BOM)</b>								
2	C3,C14	1 $\mu$ F	100 V	10%	X7R	1210	C1210X7R101105K	Venkel or equiv.
2	C4, C9	0.1 $\mu$ F	100 V	10%	X7R	603	C0603X7R101104K	Venkel or equiv.
1	C5	0.015 $\mu$ F	16 V	10%	X7R	603	C0603X7R160153K	Venkel
1	C10	470 pF	100 V	10%	X7R	603	C0603X7R101471K	Venkel or equiv.
1	C19	47 $\mu$ F	100 V	20%	Al Elec	12.5mm	EEVFK2A470Q	Panasonic
1	D8	B2100	100 V Schottky			SMB	B2100	Diodes Inc
1	L1	150 $\mu$ H	2 A			DO3340	MSS1278T-154KLD	Coilcraft
1	L2	4.7 $\mu$ H				LPS3314	LPS3314-472ML	Coilcraft
1	M1	FQD12P10	100 V			TO252 (D-PAK)	FQD12P10	Fairchild
2	R14,R46	2 k $\Omega$		1%		RC0603	CR0603-10W-2001F	Venkel or equiv.
1	R15	549 k $\Omega$		1%		RC0603	CR0603-10W-5493F	Venkel or equiv.
2	R19, R20	10 k $\Omega$		1%		RC0603	CR0603-10W-1002F	Venkel or equiv.
1	R27	10.5 $\Omega$		1%		RC0603	CR0603-16W-10R5FT	Venkel or equiv.
1	R29	2.15 k $\Omega$		1%		RC0603	CR0603-10W-2151F	Venkel or equiv.
1	R43, R47	1.3 k $\Omega$		5%		RC2512-1W	CR2512-1W-132JT	Venkel
1	U3	MIC4417				SOT143-4	MIC4417	Micrel or equiv.
1	U19	LM319				SO14	LM319	ST, Fairchild or equiv.

# Si3460-EVB

**Table 4. Si3460-EVB Bill of Materials (Continued)**

Qty	Ref	Value	Rating	Tol	Dielectric	PCB Footprint	Mfr Part #	Mfr
<b>Si3460 PSE Controller, GbE Common Mode Chokes, Status LED, and Other Optional Components</b>								
1	U2	Si3460	PSE + PWM DC-DC Controller			3x3 mm 11-p QFN	Si3460	Silicon Labs
1	D13	551-0207	LED			100 right angle	551-0207	Dailight or equiv.
1	J4	JACK PWR	2.1ID 5.5OD				16PJ031	Kobiconn
2	J7,J8	RJ45				PCB 8/8	95001-2881	Molex
1	L3a,b	FA2536			GbE chokes	FA2536	FA2536-AL	Coilcraft
1	L5	330 Ω	1.5 A	25%	Ferrite Bead	805	BLM21PG331SN1D	Murata
4	C13,C15, C17,C18	0.1 μF	250 V	0.1	For chokes	1210	C1210X7R251104K	Venkel or equiv.
1	S1	Sw_tOpen					Mouser 101-0161	
1	Power supply	12 V	1.5 A				DPS120150U-P5P	CUI inc
<b>BOM Alternates</b>								
1	Power supply	12 V	2.5 A				EMS120150-P5P-SZ	CUI inc
							DMS120250-P5P-IC	CUI inc
1	C19	39 μF	100 V	20%	Al Elec	10 mm	EEUFC2A390L	Panasonic
1	U3	TPS2828				SOT-23 5pin	TPS2828	TI
<b>Notes:</b>								
<ol style="list-style-type: none"> <li>1. R28 and R30 indicate the classification level. Full power midspan configuration is (R28 NP) (R30 = 2 kΩ).</li> <li>2. Although V1.3a EVBs are shipped with a non-shielded inductor, shielded inductor L1 is strongly recommended for EMI performance considerations (See <a href="http://www.coilcraft.com/pdfs/mss1278t.pdf">www.coilcraft.com/pdfs/mss1278t.pdf</a>).</li> <li>3. The capacitor is radial-leaded and can be used if the height restriction is not an issue.</li> </ol>								

## 11. Operating the Si3460-EVB

The Si3460-EVB itself is very simple to use. Only a basic 12 or 15 V dc power source (i.e., a wall wart) with at least an 18 W rating is needed for connection to J4. The Si3460 will automatically power up, detect the operational modes (midspan/endpoint, classification power level, and restart mode), and then begin the detection process, during which the LED flashes at 3 times per second.

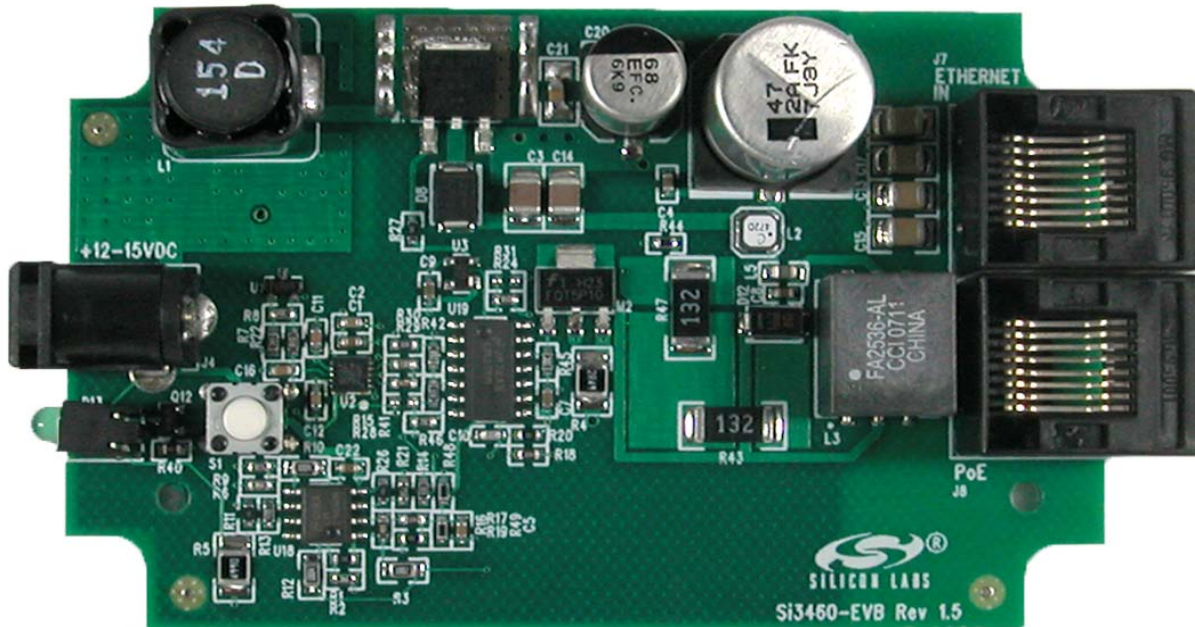

**Figure 17. Si3460-EVB**

To test the Si3460-EVB in a PoE environment, many commercial PDs are available, such as Wireless Access Points (WAPs), Voice over IP phones (VoIP), and IP-based security cameras. Any of these can be connected to the Si3460-EVB to receive PSE power while exchanging Ethernet traffic.

Another PD option is to use the Si3460-EVB with one of the Si3400/01 evaluation boards. If a Si3400 EVB is used with the Si3460-EVB, the Si3400 EVB should be configured to present a minimum load of  $\geq 0.25$  W to ensure that it draws at least 10 mA to comply with the IEEE standard.

When the Si3460 is applying power to a valid PD, the LED is continuously lit. After an error condition (e.g., an UVLO or short-circuit event) is detected, the LED flashes at 10 times per second, or until a reset is asserted, or when an open circuit is detected as determined by the operating mode of the Si3460.

Resistors R23, R25, and the programming header J6 are used for development purposes only. The Si3460 is not user programmable, and it is not recommended these components be included in actual layouts (short R23 and R25, and remove J6).

The Si3460 mode is set by resistors R28 and R30. Placeholder values of 10 k $\Omega$  are shown in the schematics. To keep the voltage level at the transistor base accurate, it is recommended that the parallel resistor combination setting the pin voltage be less than 2 k $\Omega$ . It is expected that most applications will support full power in either a midspan or endpoint application and enable automatic reset after an overload.

The reference board is shipped configured for midspan power injection with full power support and automatic retry after a fault. Resistors R28 and R30 may be replaced to support other modes of operation. See Section "5.1. Initialization and Operating Mode Configuration" on page 5 for more information.

# Si3460-EVB

---

## 12. Summary

With its integrated dc-dc converter and fully compliant PSE interface, the Si3460-EVB provides a simple and comprehensive applications solution for PSE systems designers who require IEEE-compliant PSE functionality and safe operation with standard telephone interfaces and voltages.

## 13. Ordering Guide

Ordering Part Number	Description
Si3460-EVB	Evaluation board for Si3460 single-port PSE controller for embedded applications.
Si3460-XYX-GM	Refer to the Si3460 data sheet ordering guide section for more information.

## DOCUMENT CHANGE LIST

### Revision 0.1 to Revision 0.2

- Updated Figure 17, "Si3460-EVB," on page 23.
- Revised document formatting throughout.

### Revision 0.2 to Revision 0.3

- Added Figures 4 through 9.
- Updated "2. Overview of the Si3460 and Evaluation Board" on page 1.
- Updated "4.3. Power-Up" on page 4.
- Updated "4.4. Disconnect (Power Removal)" on page 4.
- Updated "5.3. Detection" on page 6.
- Updated "5.5. Classification" on page 6.
- Updated "5.6. Power-Up" on page 7.
- Updated "5.7. Disconnect (Power Removal)" on page 7.
- Updated "5.8. Current Limit Control" on page 7.
- Updated "5.9. UVLO" on page 7.
- Updated "6.2. Isolation" on page 9.
- Added "7. Output Voltage and Load Current Waveforms" on page 11.
- Updated title of Figure 9 on page 13.
- Updated Figure 17 on page 23.
- Reformatted "10. Bill of Materials" on page 20.
- Updated schematics, PCB layouts, and BOM.

### Revision 0.3 to Revision 1.0

- Updated Table 3 on page 6.
- Updated "5.6. Power-Up" on page 7.
- Updated "5.8. Current Limit Control" on page 7.
- Updated "5.10. Status LED Function" on page 8.
- Updated "6.5. EMI and EMC" on page 9.
- Updated schematics.
  - Removed R31.
- Updated "10. Bill of Materials" on page 20.

### Revision 1.0 to Revision 1.1

- Updated "6.5. EMI and EMC" on page 9.
- Updated "8. Si3460-EVB Schematics and PCB Layout" on page 14.
- Updated Figure 10, "Si3460 and Power Circuit," on page 14.
- Updated Figure 11, "Detection and PWM Circuit," on page 15.
- Updated Figure 12, "Top Side Component Placement," on page 16.
- Updated Figure 13, "Top Side Interconnect," on page 16.
- Updated Figure 14, "Si3460 Ground Plane," on page 17.
- Updated Figure 15, "Si3460 Power Plane," on page 17.
- Updated Figure 16, "Bottom Side Interconnect," on page 18.
- Updated "9. BOM Component Considerations" on page 19.
- Updated "10. Bill of Materials" on page 20.
- Updated "11. Operating the Si3460-EVB" on page 23.

### Revision 1.1 to Revision 1.2

- Added custom watermark.