



Chipsmall Limited consists of a professional team with an average of over 10 year of expertise in the distribution of electronic components. Based in Hongkong, we have already established firm and mutual-benefit business relationships with customers from,Europe,America and south Asia,supplying obsolete and hard-to-find components to meet their specific needs.

With the principle of “Quality Parts,Customers Priority,Honest Operation,and Considerate Service”,our business mainly focus on the distribution of electronic components. Line cards we deal with include Microchip,ALPS,ROHM,Xilinx,Pulse,ON,Everlight and Freescale. Main products comprise IC,Modules,Potentiometer,IC Socket,Relay,Connector.Our parts cover such applications as commercial,industrial, and automotives areas.

We are looking forward to setting up business relationship with you and hope to provide you with the best service and solution. Let us make a better world for our industry!



Contact us

Tel: +86-755-8981 8866 Fax: +86-755-8427 6832

Email & Skype: info@chipsmall.com Web: www.chipsmall.com

Address: A1208, Overseas Decoration Building, #122 Zhenhua RD., Futian, Shenzhen, China



Description

The Si4614 DAB/DAB+ radio processor provides significant advances in size, power consumption, and performance to enable DAB/DAB+ Radio reception in automotive infotainment systems and car radios. It is designed to work with the high-performance automotive Si479x family of radio tuners.

The low power high performance Si4614 DAB/DAB+ Radio processor provides channel demodulation and source decoding of DAB/DAB+ signals delivering audio and data.

The Si4614 Radio processor provides DAB/DAB+ demodulation and decoding. In addition, the Si4614 provides an integrated clock oscillator or accepts a reference clock and supports a selectable control interface (SPI or I²C). The Si4614 processor system specifies a low minimal bill of materials, notably eliminating an external RAM memory module for channel decoding that is typically required in third party DAB/DAB+ Radio processors.

Features

- DAB/DAB+ demodulator
- Transmission Modes I, II, III, IV detection and decoding
- DAB/DAB+ audio decoder
 - PAD/XPAD outputs available
- FIC decoder
 - Ensemble info
 - Service list
 - Component info
 - Service linking info
- Full support for data services
 - Packet mode
 - Packet mode with Data Groups
 - Enhanced packet mode
 - MOT, TPEG packet outputs
- No external RAM required for channel decoding
- Flash memory interface for application program load
- Support for Si479x Zero-IF digital at 2.048 MS/s
- On-chip crystal oscillator
- Reference clock input
- SPI, I²C control interfaces
- 7x7 mm 48-pin QFN package
- Pb-free/RoHS compliant
- AEC-Q100 qualified

Applications

- Aftermarket car radio systems
- OEM automotive infotainment systems
- OEM automotive PND docking systems

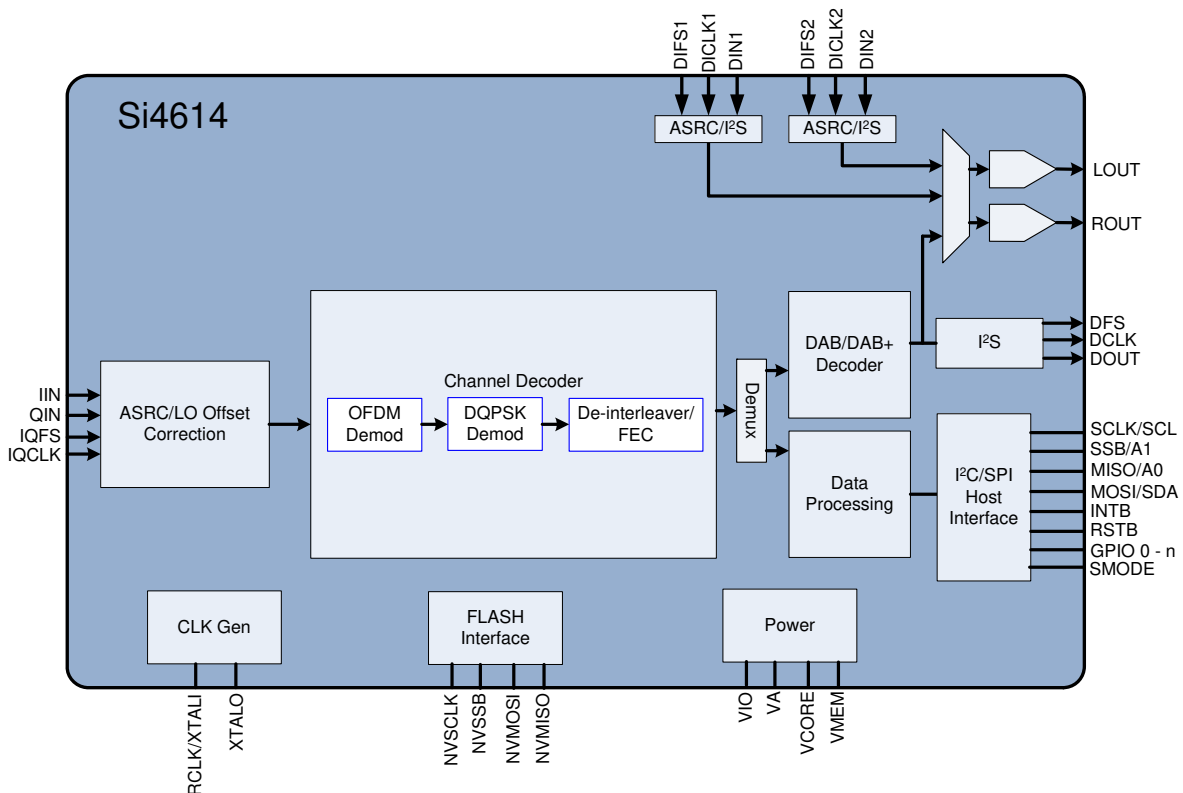

Selected Electrical Specifications

Parameter	Symbol	Test Condition	Min	Typ	Max	Unit
Analog Supply Voltage	V_A	—	1.71	1.8	2.0	V
Interface Supply Voltage	V_{IO}	—	1.62	1.8	3.6	V
Core Digital Supply Voltage	V_{CORE}	—	1.71	1.8	2.0	V
Memory Supply Voltage	V_{MEM}	—	1.71	1.8	2.0	V
Reference Clock						
Reference Clock Frequency	RCLK		—	36.864	—	MHz
Reference Clock Accuracy			-100	—	100	ppm
Reference Clock Duty Cycle			45	—	55	%
Crystal Oscillator						
Crystal Oscillator Frequency			—	36.864	—	MHz
Crystal Frequency Tolerance		37.209 MHz	-100	—	100	ppm
Load Capacitance		37.209 MHz	—	—	10	pF
ESR		37.209 MHz	—	—	50	Ω
Ambient Temperature	T_A		-40	25	85	$^{\circ}\text{C}$

Si4614-A10

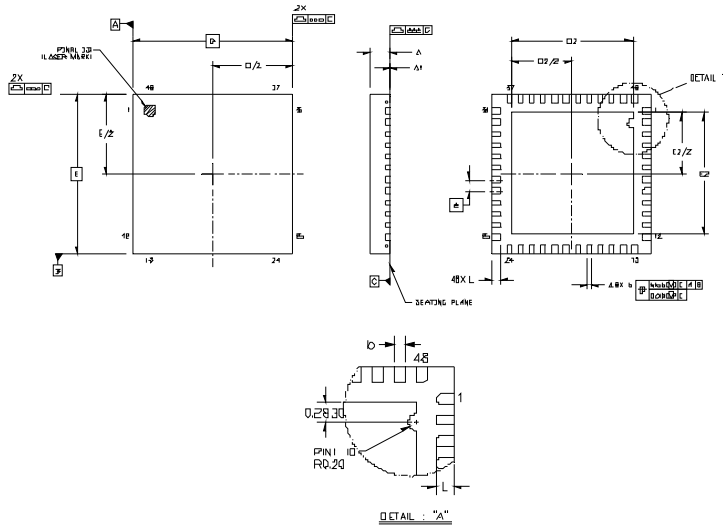

Dimension	Min	Nom	Max
A	0.80	0.85	0.90
A1	0.00	0.02	0.05
b	0.18	0.25	0.30
D		7.00 BSC	
D2	5.20	5.30	5.40
e		0.50 BSC	
E		7.00 BSC	
E2	5.20	5.30	5.40
L	0.30	0.40	0.50
aaa		0.15	
bbb		0.10	
ddd		0.05	
eee		0.08	

Notes:

1. All dimensions are shown in millimeters (mm) unless otherwise noted.
2. Dimensioning and Tolerancing per ASME Y14.5M-1994.
3. This drawing conforms to the JEDEC Solid State Outline MO-220, Variation VKKD-4.
4. Recommended card reflow profile is per the JEDEC/IPC J-STD-020 specification for Small Body Components.

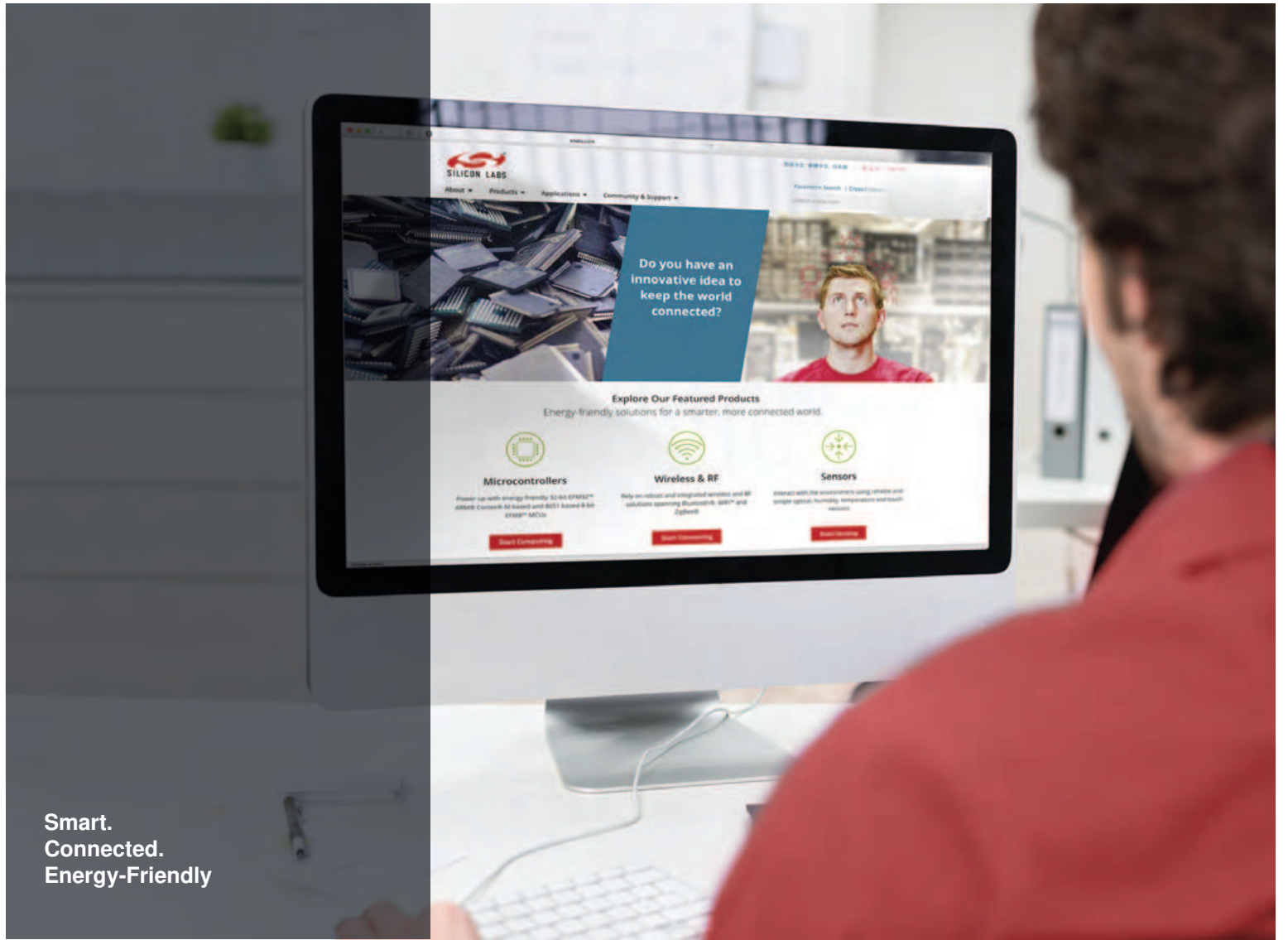

Smart.
Connected.
Energy-Friendly



Products
www.silabs.com/products

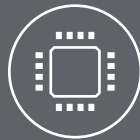

Quality
www.silabs.com/quality



Support and Community
community.silabs.com

Disclaimer

Silicon Laboratories intends to provide customers with the latest, accurate, and in-depth documentation of all peripherals and modules available for system and software implementers using or intending to use the Silicon Laboratories products. Characterization data, available modules and peripherals, memory sizes and memory addresses refer to each specific device, and "Typical" parameters provided can and do vary in different applications. Application examples described herein are for illustrative purposes only. Silicon Laboratories reserves the right to make changes without further notice and limitation to product information, specifications, and descriptions herein, and does not give warranties as to the accuracy or completeness of the included information. Silicon Laboratories shall have no liability for the consequences of use of the information supplied herein. This document does not imply or express copyright licenses granted hereunder to design or fabricate any integrated circuits. The products must not be used within any Life Support System without the specific written consent of Silicon Laboratories. A "Life Support System" is any product or system intended to support or sustain life and/or health, which, if it fails, can be reasonably expected to result in significant personal injury or death. Silicon Laboratories products are generally not intended for military applications. Silicon Laboratories products shall under no circumstances be used in weapons of mass destruction including (but not limited to) nuclear, biological or chemical weapons, or missiles capable of delivering such weapons.

Trademark Information

Silicon Laboratories Inc., Silicon Laboratories, Silicon Labs, SiLabs and the Silicon Labs logo, CMEMS®, EFM, EFM32, EFR, Energy Micro, Energy Micro logo and combinations thereof, "the world's most energy friendly microcontrollers", Ember®, EZLink®, EZMac®, EZRadio®, EZRadioPRO®, DSPLL®, ISOmodem®, Precision32®, ProSLIC®, SiPHY®, USBXpress® and others are trademarks or registered trademarks of Silicon Laboratories Inc. ARM, CORTEX, Cortex-M3 and THUMB are trademarks or registered trademarks of ARM Holdings. Keil is a registered trademark of ARM Limited. All other products or brand names mentioned herein are trademarks of their respective holders.



Silicon Laboratories Inc.
400 West Cesar Chavez
Austin, TX 78701
USA

<http://www.silabs.com>