



Chipsmall Limited consists of a professional team with an average of over 10 year of expertise in the distribution of electronic components. Based in Hongkong, we have already established firm and mutual-benefit business relationships with customers from,Europe,America and south Asia,supplying obsolete and hard-to-find components to meet their specific needs.

With the principle of “Quality Parts,Customers Priority,Honest Operation,and Considerate Service”,our business mainly focus on the distribution of electronic components. Line cards we deal with include Microchip,ALPS,ROHM,Xilinx,Pulse,ON,Everlight and Freescale. Main products comprise IC,Modules,Potentiometer,IC Socket,Relay,Connector.Our parts cover such applications as commercial,industrial, and automotives areas.

We are looking forward to setting up business relationship with you and hope to provide you with the best service and solution. Let us make a better world for our industry!



Contact us

Tel: +86-755-8981 8866 Fax: +86-755-8427 6832

Email & Skype: info@chipsmall.com Web: www.chipsmall.com

Address: A1208, Overseas Decoration Building, #122 Zhenhua RD., Futian, Shenzhen, China



Description

The Si4683 single-chip digital receiver is one member of a family of 100% CMOS digital radio broadcast receiver ICs from Silicon Labs. The Si468x family offers a complete and cost-effective digital radio solution integrating the RF tuner, baseband and audio processing on a single die. The high level of integration provides significant customer benefits compared to traditional digital radio solutions including a reduction in system implementation complexity, validation and testing, and improved reliability and manufacturability.

The Si4683 is compatible with the iBiquity Digital and NRSC-5 standards for AM/FM In-Band-On-Channel (IBOC) digital radio broadcasting, integrating digital channel demodulation and decoding functions, along with audio decoding and IBOC analog-digital blend. The Si4683 is capable of tuning HD Radio™ reception to cover additional AM/FM frequencies for future IBOC adoption outside of North America. The Si4683 additionally supports IBOC multicasting, as well as the full-range of HD Radio data services, such as PSD (Program Service Data), Artist Experience, iTunes® Tagging, Bookmark and real-time traffic, with the appropriate external decoders.

The Si4683 additionally supports worldwide AM/FM radio reception and incorporates a fully integrated decoder for the European Radio Data System (RDS) and the North American Radio Broadcast Data System (RBDS) including all required symbol decoding, block synchronization, error detection, and error correction functions.

[For more information, visit the Si468x Digital Radio Receivers web page.](#)

Features

- Worldwide FM band support (76–108 MHz)
- Worldwide AM band support (520–1710 kHz)
- Advanced RDS/RBDS decoder
- AM/FM HD Radio™ support
- Integrated HD blend
- Advanced seek functionality
- Advanced audio DSP processing
- I²S digital audio out with ASRC
- Integrated 97 dB stereo audio DAC
- Concurrent I²S/L-R stereo audio out
- Full range of signal quality metrics
- Fully-integrated VCO / PLL / synthesizer
- SPI and I²C host control interfaces
- QFN 48-pin, 7x7x0.85 mm

Applications

- Clock and tabletop radios
- Stereo boomboxes
- Mini/micro systems
- Docking stations

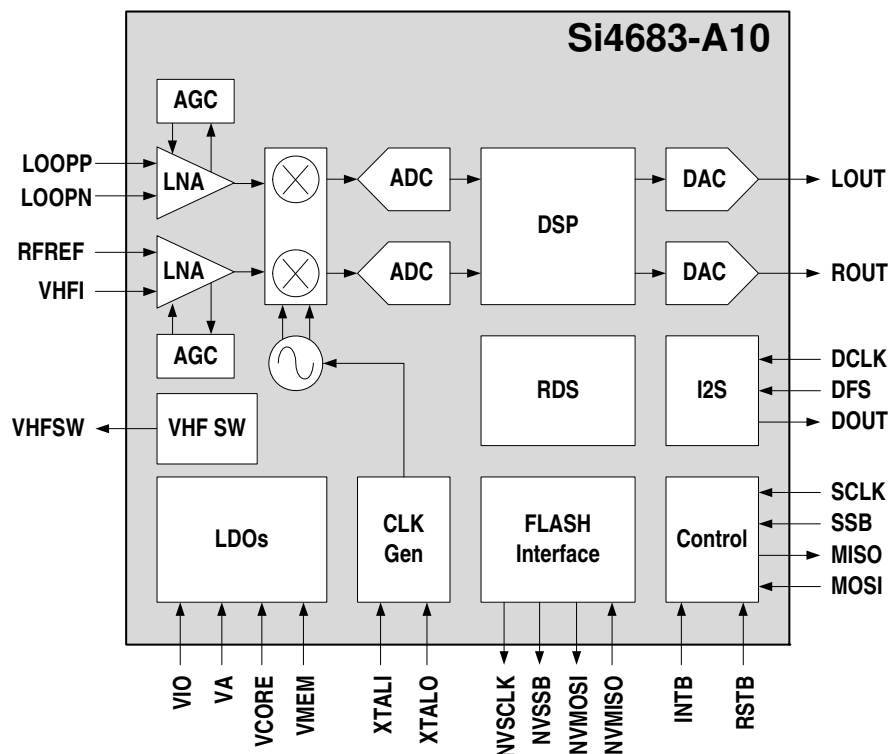

Selected Electrical Specifications

Parameter	Symbol	Test Condition	Min	Typ	Max	Unit
Ambient Temperature	T_A		-40	25	85	°C
Analog Supply Voltage	V_A		1.71	1.8	2.0	V
Interface Supply Voltage	V_{IO}		1.62	1.8	3.6	V
Core Digital Supply Voltage	V_{CORE}		1.62	1.8	2.0	V
Memory Supply Voltage	V_{MEM}		1.62	1.8	2.0	V
Analog FM						
Input Frequency	F_{rf}		76	—	108	MHz
Seek/Tune Time			—	—	60	ms/ch
FM HD						
Input Frequency	F_{rf}		87.5	—	108	MHz
Seek/Tune Time			—	—	60	ms/ch
Analog AM						
Input Frequency	F_{rf}		520	—	1710	kHz
Seek/Tune Time			—	—	60	ms/ch
AM HD						
Input Frequency	F_{rf}		520	—	1710	kHz
Seek/Tune Time			—	—	60	ms/ch

Si4683-A10-GM

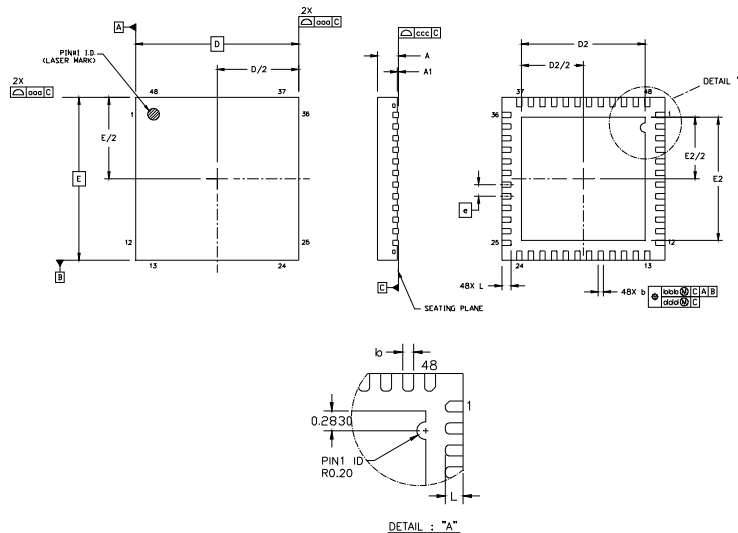

Dimension	Min	Nom	Max
A	0.80	0.85	0.90
A1	0.00	0.02	0.05
b	0.18	0.25	0.30
D		7.00 BSC	
D2	5.20	5.30	5.40
e		0.50 BSC	
E		7.00 BSC	
E2	5.20	5.30	5.40
L	0.30	0.40	0.50
aaa		0.15	
bbb		0.10	
ddd		0.05	
eee		0.08	

Notes:

- All dimensions are shown in millimeters (mm) unless otherwise noted.
- Dimensioning and tolerancing per ASME Y14.5M-1994.
- This drawing conforms to JEDEC Outline MO-220, Variation VKKD-4.
- Recommended card reflow profile is per the JEDEC/IPC J-STD-020 specification for Small Body Components.