



Chipsmall Limited consists of a professional team with an average of over 10 year of expertise in the distribution of electronic components. Based in Hongkong, we have already established firm and mutual-benefit business relationships with customers from,Europe,America and south Asia,supplying obsolete and hard-to-find components to meet their specific needs.

With the principle of “Quality Parts,Customers Priority,Honest Operation,and Considerate Service”,our business mainly focus on the distribution of electronic components. Line cards we deal with include Microchip,ALPS,ROHM,Xilinx,Pulse,ON,Everlight and Freescale. Main products comprise IC,Modules,Potentiometer,IC Socket,Relay,Connector.Our parts cover such applications as commercial,industrial, and automotives areas.

We are looking forward to setting up business relationship with you and hope to provide you with the best service and solution. Let us make a better world for our industry!



## Contact us

Tel: +86-755-8981 8866 Fax: +86-755-8427 6832

Email & Skype: info@chipsmall.com Web: www.chipsmall.com

Address: A1208, Overseas Decoration Building, #122 Zhenhua RD., Futian, Shenzhen, China



## BROADCAST FM RADIO TUNER FOR PORTABLE APPLICATIONS

### Features

- Worldwide FM band support (76–108 MHz)
- Digital low-IF receiver
- Frequency synthesizer with integrated VCO
- Adjustable seek tuning
- Automatic frequency control (AFC)
- Automatic gain control (AGC)
- Excellent overload immunity
- Signal strength measurement
- Programmable de-emphasis (50/75  $\mu$ s)
- Adaptive noise suppression
- Adjustable soft mute
- Volume control
- Line-level analog output
- 32.768 kHz reference clock
- 2-wire and 3-wire control interface
- 2.7 to 5.5  $V_D$  supply voltage
- 2.7 to 5.5  $V_A$  supply voltage
- Integrated LDO regulator allows direct connection to battery
- 2.5 x 2.5 mm 16-pin QFN package
  - Pb-free/RoHS compliant
- RDS/RBDS Processor (Si4709)

### Applications

- Cellular handsets
- Portable navigation
- USB FM radio
- MP3 players
- Consumer electronics
- PDAs
- Portable radios
- Notebook PCs

### Description

The Si4708/09 is the world's smallest FM broadcast receiver, integrating the complete tuner function from antenna input to stereo audio output with RDS (Si4709).

### Functional Block Diagram

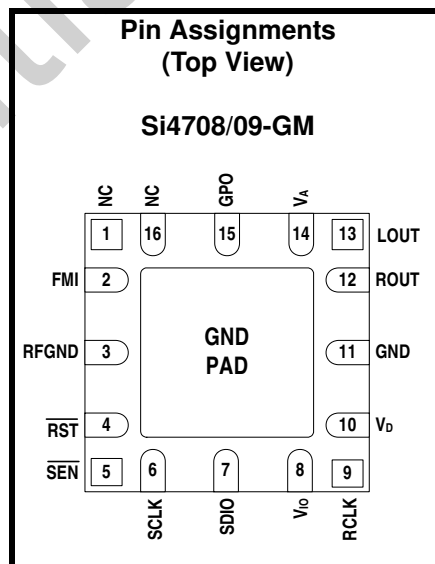
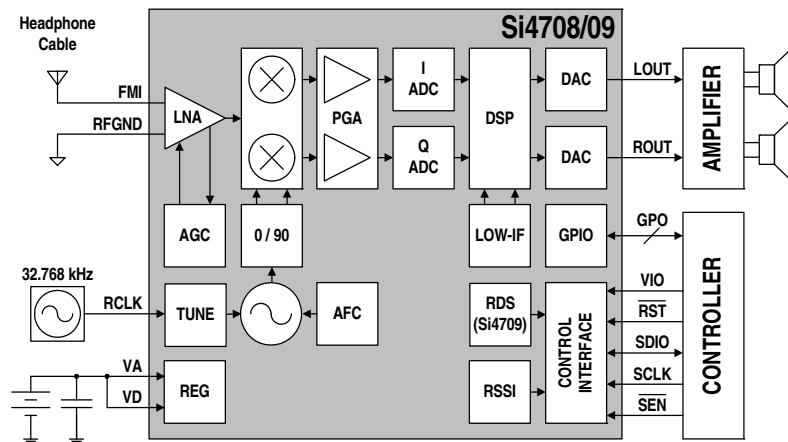

Patents pending

### Notes:

- To ensure proper operation and FM receiver performance, follow the guidelines in "AN350: Si4708/09 Antenna, Schematic, Layout, and Design Guidelines" and "AN383: Si47xx Antenna Selection and Universal Layout Guidelines." Silicon Laboratories will evaluate schematics and layouts for qualified customers.
- Place Si4708/09 as close as possible to antenna jack and keep the FMI trace as short as possible.

Confidential

---

**TABLE OF CONTENTS**

---

<b><u>Section</u></b>	<b><u>Page</u></b>
<b>1. Electrical Specifications</b> .....	<b>4</b>
<b>2. Typical Application Schematic</b> .....	<b>12</b>
<b>3. Bill of Materials</b> .....	<b>12</b>
<b>4. Functional Description</b> .....	<b>13</b>
4.1. Overview .....	13
4.2. FM Receiver .....	13
4.3. General Purpose Output .....	14
4.4. RDS/RBDS Processor and Functionality .....	14
4.5. Stereo Audio Processing .....	14
4.6. Tuning .....	15
4.7. Reference Clock .....	16
4.8. Control Interface .....	16
4.9. Reset, Powerup, and Powerdown .....	16
4.10. Audio Output Summation .....	17
4.11. Initialization Sequence .....	17
4.12. Programming Guide .....	18
<b>5. Register Summary</b> .....	<b>19</b>
<b>6. Register Descriptions</b> .....	<b>20</b>
<b>7. Pin Descriptions: Si4708/09-GM</b> .....	<b>33</b>
<b>8. Ordering Guide</b> .....	<b>34</b>
<b>9. Package Markings (Top Marks)</b> .....	<b>35</b>
9.1. Si4708 Top Mark .....	35
9.2. Si4709 Top Mark .....	35
9.3. Top Mark Explanation .....	35
<b>10. Package Outline: Si4708/09-GM</b> .....	<b>36</b>
<b>11. PCB Land Pattern: Si4708/09-GM</b> .....	<b>37</b>
<b>12. Additional Reference Resources</b> .....	<b>39</b>
<b>Document Change List</b> .....	<b>40</b>
<b>Contact Information</b> .....	<b>42</b>

# Si4708/09-B

## 1. Electrical Specifications

**Table 1. Recommended Operating Conditions**

Parameter	Symbol	Test Condition	Min	Typ	Max	Unit
Digital Supply Voltage	$V_D$		2.7	—	5.5	V
Analog Supply Voltage	$V_A$		2.7	—	5.5	V
Interface Supply Voltage	$V_{IO}$		1.5	—	3.6	V
Ambient Temperature	$T_A$		-20	25	85	°C
Digital Power Supply Power-Up Rise Time	$V_{DRISE}$		10	—	—	μs
Analog Power Supply Power-Up Rise Time	$V_{ARISE}$		10	—	—	μs
Interface Power Supply Power-Up Rise Time	$V_{IRISE}$		10	—	—	μs

**Note:** All minimum and maximum specifications are guaranteed and apply across the recommended operating conditions. Typical values apply at  $V_D = V_A = 3.3$  V and 25 °C unless otherwise stated. Parameters are tested in production unless otherwise stated.

**Table 2. Absolute Maximum Ratings<sup>1,2</sup>**

Parameter	Symbol	Value	Unit
Digital Supply Voltage	$V_D$	-0.5 to 5.8	V
Analog Supply Voltage	$V_A$	-0.5 to 5.8	V
Interface Supply Voltage	$V_{IO}$	-0.5 to 3.9	V
Input Current <sup>3</sup>	$I_{IN}$	±10	mA
Input Voltage <sup>3</sup>	$V_{IN}$	-0.3 to ( $V_{IO} + 0.3$ )	V
Operating Temperature	$T_{OP}$	-40 to 95	°C
Storage Temperature	$T_{STG}$	-55 to 150	°C
RF Input Level <sup>4</sup>		0.4	$V_{pK}$

**Notes:**

1. Permanent device damage may occur if the above Absolute Maximum Ratings are exceeded. Functional operation should be restricted to the conditions as specified in the operational sections of this data sheet. Exposure beyond recommended operating conditions for extended periods may affect device reliability.
2. The Si4708/09 device is a high-performance RF integrated circuit with an ESD rating of < 2 kV HBM. Handling and assembly of this device should only be done at ESD-protected workstations.
3. For input pins SCLK, SEN, SDIO, RST, RCLK, and GPO.
4. At RF input pins.



**Table 3. DC Characteristics<sup>1</sup>** $(V_D = V_A = 2.7 \text{ to } 3.6 \text{ V}, V_{IO} = 1.5 \text{ to } 3.6 \text{ V}, T_A = -20 \text{ to } 85 \text{ }^\circ\text{C})$ 

Parameter	Symbol	Test Condition	Min	Typ	Max	Unit
Analog Operating Supply Current <sup>2</sup>	$I_A$	ENABLE = 1	—	10.8	—	mA
Digital Operating Supply Current <sup>2</sup>	$I_D$	ENABLE = 1	—	3.3	—	mA
Interface Operating Supply Current <sup>2</sup>	$I_{IO}$	ENABLE = 1	—	0.3	—	mA
Total Operating Supply Current <sup>2,3,4</sup>	$I_{OP}$	ENABLE = 1	—	14.6	16.9	mA
Total Operating Supply Current <sup>2,3,4,5</sup>	$I_{OP}$	ENABLE = 1 Low SNR signal	—	15.5	17.8	mA
Total Operating Supply Current <sup>2,3,4,6</sup>	$I_{OP}$	ENABLE = 1 RDS = 1	—	15.2	17.4	mA
Total Operating Supply Current <sup>2,3,4,5,6</sup>	$I_{OP}$	ENABLE = 1 RDS = 1, Low SNR signal	—	16.0	17.8	mA
Analog Powerdown Supply Current <sup>2,7</sup>	$I_{APD}$	ENABLE = 0	—	3.5	—	$\mu\text{A}$
Digital Powerdown Supply Current <sup>2,7</sup>	$I_{DPD}$	ENABLE = 0	—	2.5	—	$\mu\text{A}$
Interface Powerdown Supply Current <sup>2,7</sup>	$I_{IOPD}$	ENABLE = 0 SCLK, RCLK inactive	—	2.5	—	$\mu\text{A}$
Total Powerdown Supply Current <sup>2,7</sup>	$I_{PD}$	ENABLE = 0	—	8.5	12.0	$\mu\text{A}$
High Level Input Voltage <sup>8</sup>	$V_{IH}$		$0.7 \times V_{IO}$	—	$V_{IO} + 0.3$	V
Low Level Input Voltage <sup>8</sup>	$V_{IL}$		-0.3	—	$0.3 \times V_{IO}$	V
High Level Input Current <sup>8</sup>	$I_{IH}$	$V_{IN} = V_{IO} = 3.6 \text{ V}$	-10	—	10	$\mu\text{A}$
Low Level Input Current <sup>8</sup>	$I_{IL}$	$V_{IN} = 0 \text{ V},$ $V_{IO} = 3.6 \text{ V}$	-10	—	10	$\mu\text{A}$
High Level Output Voltage <sup>9</sup>	$V_{OH}$	$I_{OUT} = 500 \mu\text{A}$	$0.8 \times V_{IO}$	—	—	V
Low Level Output Voltage <sup>9</sup>	$V_{OL}$	$I_{OUT} = -500 \mu\text{A}$	—	—	$0.2 \times V_{IO}$	V

**Notes:**

- All specifications for the Si4708 unless otherwise noted.
- Refer to Register 02h, "Power Configuration" on page 21 for ENABLE bit description.
- The LNA is automatically switched to higher current mode for optimum sensitivity in low SNR conditions.
- Analog and digital supply currents are simultaneously adjusted based on SNR level.
- Stereo and/or RDS functionality are disabled at low SNR levels.
- RDS functionality only available for Si4709.
- Refer to Section 4.9. "Reset, Powerup, and Powerdown" on page 16.
- For input pins SCLK, SEN, SDIO, RST, RCLK, and GPO.
- For output pins SDIO and GPO.

**Table 4. Reset Timing Characteristics (Busmode Select Method)<sup>1,2</sup>**

( $V_{DD} = 2.7$  to  $5.5$  V,  $V_{IO} = 1.5$  to  $3.6$  V,  $T_A = -20$  to  $85$  °C)

Parameter	Symbol	Min	Typ	Max	Unit
SEN Input to $\overline{RST}$ ↑ Setup	$t_{SRST1}$	30	—	—	ns
SEN Input to $\overline{RST}$ ↑ Hold	$t_{HRST1}$	30	—	—	ns

**Notes:**

1. When selecting 2-wire Mode, the user must ensure that a 2-wire start condition (falling edge of SDIO while SCLK is high) does not occur within 300 ns before the rising edge of  $\overline{RST}$ .
2. When selecting 3-wire Mode, the user must ensure that a rising edge of SCLK does not occur within 300 ns before the rising edge of  $\overline{RST}$ .

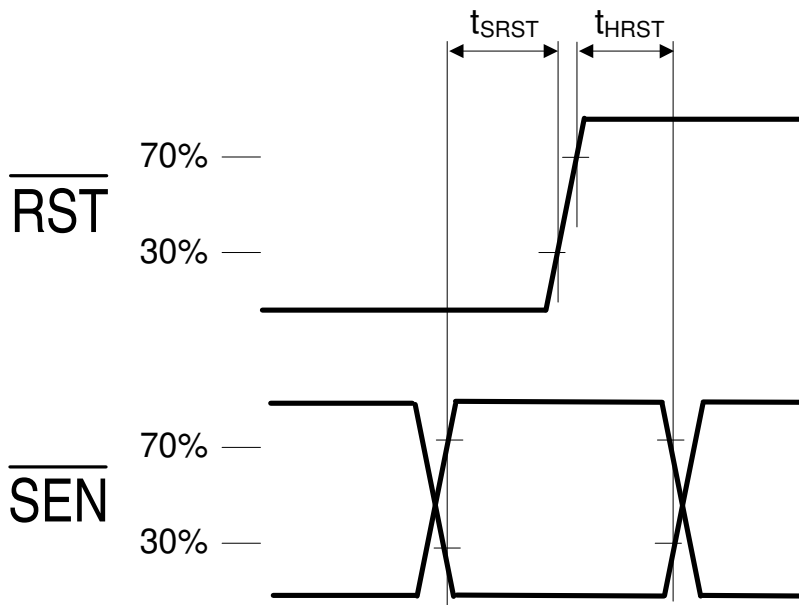
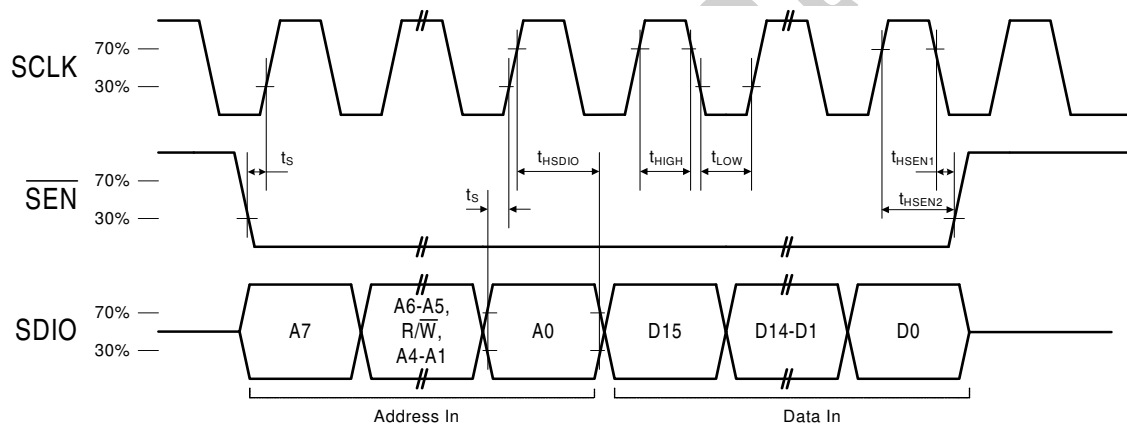
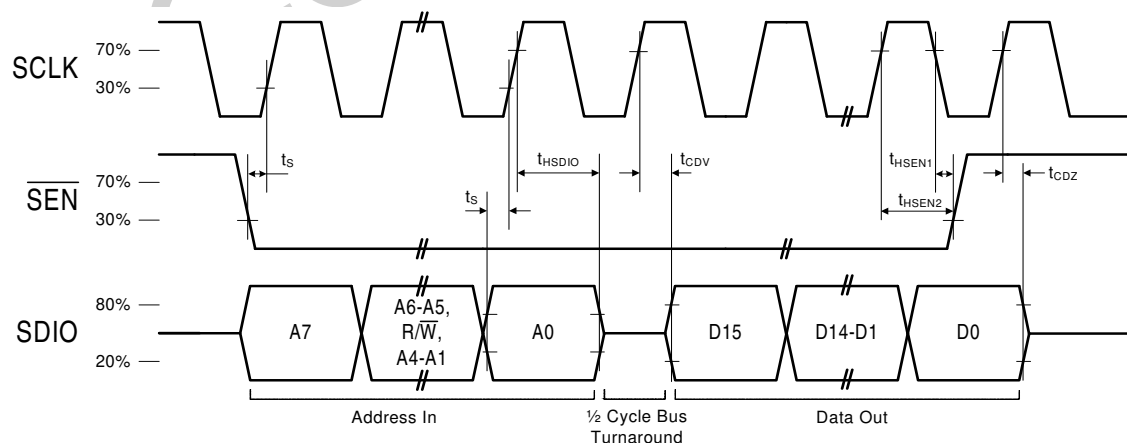

**Figure 1. Reset Timing Parameters**

**Table 5. 3-Wire Control Interface Characteristics** $(V_D = V_A = 2.7 \text{ to } 5.5 \text{ V}, V_{IO} = 1.5 \text{ to } 3.6 \text{ V}, T_A = -20 \text{ to } 85 \text{ }^\circ\text{C})$ 

Parameter	Symbol	Test Condition	Min	Typ	Max	Unit
SCLK Frequency	$f_{CLK}$		0	—	2.5	MHz
SCLK High Time	$t_{HIGH}$		25	—	—	ns
SCLK Low Time	$t_{LOW}$		25	—	—	ns
SDIO Input, $\overline{SEN}$ to SCLK $\uparrow$ Setup	$t_s$		20	—	—	ns
SDIO Input to SCLK $\uparrow$ Hold	$t_{HSDIO}$		10	—	—	ns
$\overline{SEN}$ Input to SCLK $\downarrow$ Hold	$t_{HSEN1}$		10	—	—	ns
$\overline{SEN}$ Input to SCLK $\uparrow$ Hold	$t_{HSEN2}$		10	—	—	ns
SCLK $\uparrow$ to SDIO Output Valid	$t_{CDV}$	Read	2	—	25	ns
SCLK $\uparrow$ to SDIO Output High Z	$t_{CDZ}$	Read	2	—	25	ns

**Note:** When selecting 3-wire Mode, the user must ensure that a rising edge of SCLK does not occur within 300 ns before the rising edge of RST.

**Figure 2. 3-Wire Control Interface Write Timing Parameters****Figure 3. 3-Wire Control Interface Read Timing Parameters**



# Si4708/09-B

**Table 6. 2-Wire Control Interface Characteristics<sup>1,2,3</sup>**

( $V_D = V_A = 2.7$  to  $5.5$  V,  $V_{IO} = 1.5$  to  $3.6$  V,  $T_A = -20$  to  $85$  °C)

Parameter	Symbol	Test Condition	Min	Typ	Max	Unit
SCLK Frequency	$f_{SCL}$		0	—	400	kHz
SCLK Low Time	$t_{LOW}$		1.3	—	—	$\mu$ s
SCLK High Time	$t_{HIGH}$		0.6	—	—	$\mu$ s
SCLK Input to SDIO $\downarrow$ Setup (START)	$t_{SU:STA}$		0.6	—	—	$\mu$ s
SCLK Input to SDIO $\downarrow$ Hold (START)	$t_{HD:STA}$		0.6	—	—	$\mu$ s
SDIO Input to SCLK $\uparrow$ Setup	$t_{SU:DAT}$		100	—	—	ns
SDIO Input to SCLK $\downarrow$ Hold <sup>4,5</sup>	$t_{HD:DAT}$		0	—	900	ns
SCLK input to SDIO $\uparrow$ Setup (STOP)	$t_{SU:STO}$		0.6	—	—	$\mu$ s
STOP to START Time	$t_{BUF}$		1.3	—	—	$\mu$ s
SDIO Output Fall Time	$t_{f:OUT}$		$20 + 0.1 C_b$	—	250	ns
SDIO Input, SCLK Rise/Fall Time	$t_{r:IN}$ $t_{f:IN}$		$20 + 0.1 C_b$	—	300	ns
SCLK, SDIO Capacitive Loading	$C_b$		—	—	50	pF
Input Filter Pulse Suppression	$t_{SP}$		—	—	50	ns

**Notes:**

1. When  $V_{IO} = 0$  V, SCLK and SDIO are low impedance.
2. When selecting 2-wire mode, the user must ensure that SCLK is high during the rising edge of  $\overline{RST}$ , and stays high until after the 1st start condition.
3. When selecting 2-wire Mode, the user must ensure that a 2-wire start condition (falling edge of SDIO while SCLK is high) does not occur within 300 ns before the rising edge of  $\overline{RST}$ .
4. As a 2-wire transmitter, the Si4708/09-B delays SDIO by a minimum of 300 ns from the  $V_{IH}$  threshold of SCLK to comply with the 0 ns  $t_{HD:DAT}$  specification.
5. The maximum  $t_{HD:DAT}$  has only to be met when  $f_{SCL} = 400$  kHz. At frequencies below 400 kHz,  $t_{HD:DAT}$  may be violated so long as all other timing parameters are met.

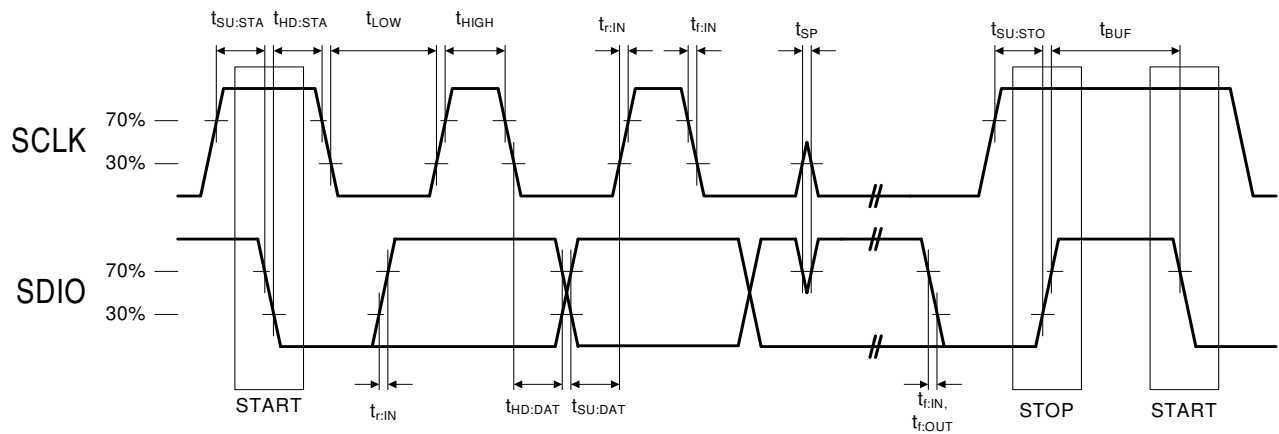

Figure 4. 2-Wire Control Interface Read and Write Timing Parameters

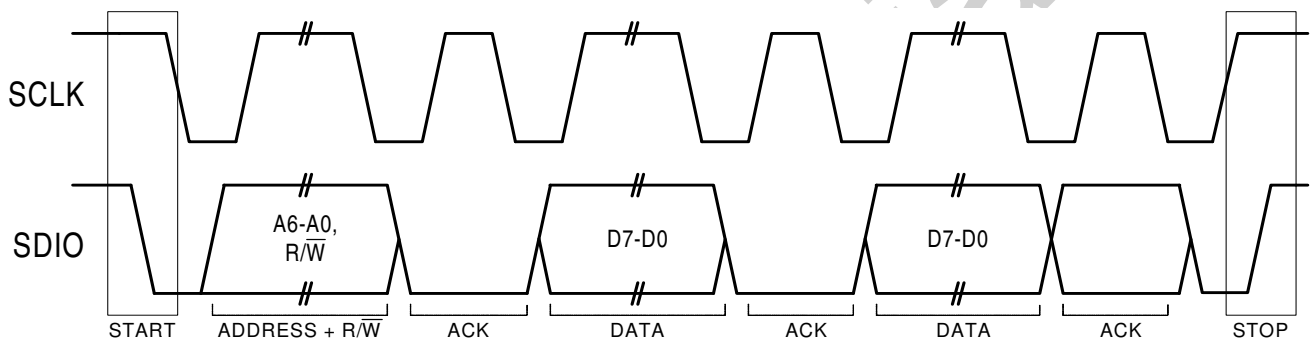

Figure 5. 2-Wire Control Interface Read and Write Timing Diagram

# Si4708/09-B

**Table 7. FM Receiver Characteristics<sup>1,2</sup>**

( $V_D = V_A = 2.7$  to  $5.5$  V,  $V_{IO} = 1.5$  to  $3.6$  V,  $T_A = -20$  to  $85$  °C)

Parameter	Symbol	Test Condition	Min	Typ	Max	Unit
Input Frequency	$f_{RF}$		76	—	108	MHz
Sensitivity <sup>3,4,5,6,7</sup>		(S+N)/N = 26 dB	—	1.7	3.5	$\mu$ VEMF
Sensitivity (50 $\Omega$ matching network) <sup>3,4,5,6,8</sup>		(S+N)/N = 26 dB	—	1.1	—	$\mu$ VEMF
RDS Sensitivity <sup>8</sup>		$\Delta f = 2$ kHz, RDS BLER < 5%	—	15	—	$\mu$ VEMF
LNA Input Resistance <sup>8,9</sup>			3	4	5	k $\Omega$
LNA Input Capacitance <sup>8,9</sup>			4	5	6	pF
Input IP3 <sup>8,10</sup>			104	106	—	dB $\mu$ VEMF
AM Suppression <sup>3,4,5,8,9</sup>		m = 0.3	40	55	—	dB
Adjacent Channel Selectivity		$\pm 200$ kHz	35	50	—	dB
Alternate Channel Selectivity		$\pm 400$ kHz	60	70	—	dB
Spurious Response Rejection <sup>8</sup>		In-band	35	—	—	dB
RCLK Frequency			—	32.768	—	kHz
RCLK Frequency Tolerance <sup>11</sup>		SPACE[1:0] = 00 or 01	-200	—	200	ppm
		SPACE[1:0] = 10	-50	—	50	
Audio Output Voltage <sup>3,4,5,9</sup>			72	80	90	mV <sub>RMS</sub>
Audio Output L/R Imbalance <sup>3,4,9,12</sup>			—	—	1	dB
Audio Frequency Response Low <sup>8</sup>		-3 dB	—	—	30	Hz
Audio Frequency Response High <sup>8</sup>		-3 dB	15	—	—	kHz
Audio Stereo Separation <sup>3,9,12</sup>			25	—	—	dB

**Notes:**

- Additional testing information is available in Application Note AN388. Volume = maximum for all tests.
- Important Note:** To ensure proper operation and FM receiver performance, follow the guidelines in "AN350: Si4708/09 Antenna, Schematic, Layout, and Design Guidelines." Silicon Laboratories will evaluate schematics and layouts for qualified customers.
- $F_{MOD} = 1$  kHz, 75  $\mu$ s de-emphasis
- MONO = 1, and L = R unless noted otherwise.
- $\Delta f = 22.5$  kHz.
- $B_{AF} = 300$  Hz to 15 kHz, A-weighted.
- Typical sensitivity with headphone matching network.
- Guaranteed by characterization.
- $V_{EMF} = 1$  mV.
- $|f_2 - f_1| > 1$  MHz,  $f_0 = 2 \times f_1 - f_2$ . AGC is disabled by setting AGCD = 1. Refer to "6. Register Descriptions" on page 20.
- The channel spacing is selected with the SPACE[1:0] bits. Refer to "6. Register Descriptions" on page 20. Seek/Tune timing is guaranteed for 100 and 200 kHz channel spacing.  $\pm 50$  ppm PCLK tolerance required for 50 kHz channel spacing.
- $\Delta f = 75$  kHz.
- The de-emphasis time constant is selected with the DE bit. Refer to "6. Register Descriptions" on page 20.
- At LOUT and ROUT pins.
- Do not enable STC interrupts before the powerup time is complete. If STC interrupts are enabled before the powerup time is complete, an interrupt will be generated within the powerup interval when the initial default tune operation is complete. See "AN349: Si4708/09 Programming Guide" for more information.
- Minimum and maximum at room temperature (25 °C).

**Table 7. FM Receiver Characteristics<sup>1,2</sup> (Continued)** $(V_D = V_A = 2.7$  to  $5.5$  V,  $V_{IO} = 1.5$  to  $3.6$  V,  $T_A = -20$  to  $85$  °C)

Parameter	Symbol	Test Condition	Min	Typ	Max	Unit
Mono/Stereo Switching Level <sup>3,8,12</sup>		BLNDADJ = 10 10 dB stereo separation	—	34	—	dB $\mu$ VEMF
Audio Mono S/N <sup>3,4,5,6,9</sup>			55	60	—	dB
Audio Stereo S/N <sup>3,5,6,8</sup>		BLNDADJ = 10	—	58	—	dB
Audio THD <sup>3,4,9,12</sup>			—	0.1	0.5	%
De-emphasis Time Constant <sup>13</sup>		DE = 0	70	75	80	$\mu$ s
		DE = 1	45	50	54	$\mu$ s
Audio Common Mode Voltage <sup>14</sup>		ENABLE = 1	0.65	0.8	0.9	V
Audio Common Mode Voltage <sup>14</sup>		ENABLE = 0 AHIZEN = 1	—	$0.5 \times V_{IO}$	—	V
Audio Output Load Resistance <sup>8,14</sup>	$R_L$	Single-ended	10	—	—	k $\Omega$
Audio Output Load Capacitance <sup>8,14</sup>	$C_L$	Single-ended	—	—	50	pF
Seek/Tune Time <sup>8,11</sup>		SPACE[1:0] = 0x, RCLK tolerance = 200 ppm, (x = 0 or 1)	—	—	60	ms/ channel
Powerup Time <sup>15</sup>		From powerdown (Write ENABLE bit to 1)	—	—	110	ms
RSSI Offset <sup>16</sup>		Input levels of 8 and 60 dB $\mu$ V at RF input	-3	—	3	dB

**Notes:**

- Additional testing information is available in Application Note AN388. Volume = maximum for all tests.
- Important Note:** To ensure proper operation and FM receiver performance, follow the guidelines in "AN350: Si4708/09 Antenna, Schematic, Layout, and Design Guidelines." Silicon Laboratories will evaluate schematics and layouts for qualified customers.
- $F_{MOD} = 1$  kHz, 75  $\mu$ s de-emphasis
- MONO = 1, and L = R unless noted otherwise.
- $\Delta f = 22.5$  kHz.
- $B_{AF} = 300$  Hz to 15 kHz, A-weighted.
- Typical sensitivity with headphone matching network.
- Guaranteed by characterization.
- $V_{EMF} = 1$  mV.
- $|f_2 - f_1| > 1$  MHz,  $f_0 = 2 \times f_1 - f_2$ . AGC is disabled by setting AGCD = 1. Refer to "6. Register Descriptions" on page 20.
- The channel spacing is selected with the SPACE[1:0] bits. Refer to "6. Register Descriptions" on page 20. Seek/Tune timing is guaranteed for 100 and 200 kHz channel spacing.  $\pm 50$  ppm PCLK tolerance required for 50 kHz channel spacing.
- $\Delta f = 75$  kHz.
- The de-emphasis time constant is selected with the DE bit. Refer to "6. Register Descriptions" on page 20.
- At LOUT and ROUT pins.
- Do not enable STC interrupts before the powerup time is complete. If STC interrupts are enabled before the powerup time is complete, an interrupt will be generated within the powerup interval when the initial default tune operation is complete. See "AN349: Si4708/09 Programming Guide" for more information.
- Minimum and maximum at room temperature (25 °C).

# Si4708/09-B

## 2. Typical Application Schematic

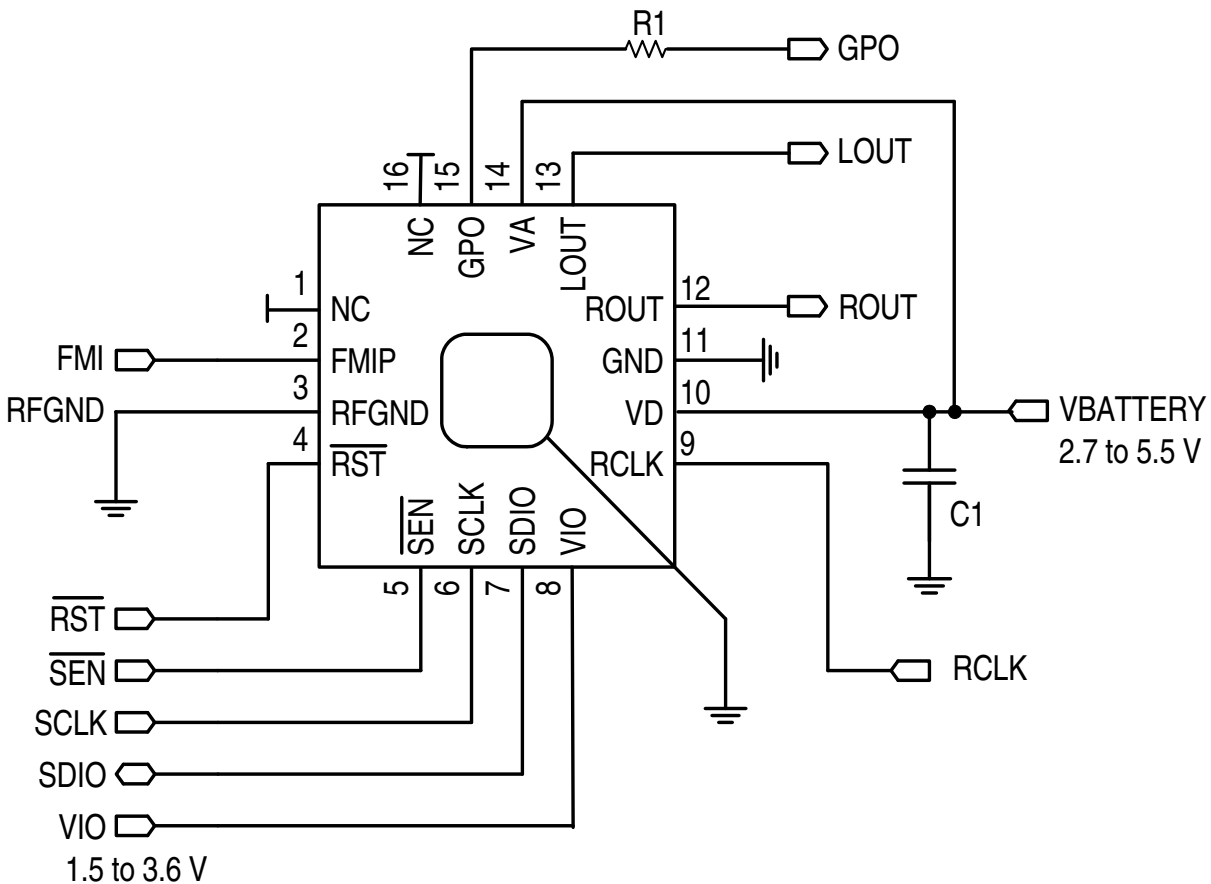

### Notes:

1. Place C1 close to  $V_D$  pin.
2. All grounds connect directly to GND plane on PCB.
3. Pins 1 and 16 are no connects, leave floating.
4. **Important Note:** FM Receiver performance is subject to adherence to antenna design guidelines in "AN350: Si4708/09 Antenna, Schematic, Layout, and Design Guidelines." Failure to use these guidelines may negatively affect the performance of the Si4708/09, particularly in weak signal and noisy environments. Silicon Laboratories will evaluate schematics and layouts for qualified customers.
5. Pin 2 connects to the antenna interface, refer to "AN350: Si4708/09 Antenna, Schematic, Layout, and Design Guidelines" and "AN383: Si47xx Antenna, Schematic, Layout, and Design Guidelines."
6. RFGND should be locally isolated from GND, refer to "AN350: Si4708/09 Antenna, Schematic, Layout, and Design Guidelines."
7. Place Si4708/09 as close as possible to antenna jack and keep the FMI trace as short as possible.
8.  $V_A$  and  $V_D$  may be supplied from the same  $V_{BAT}$  or may be supplied by independent power supplies.
9. Place R1 on the opposite side of the PCB as the tuner (as close to pin 15 as possible), and route the GPO trace to the system controller on this layer.

## 3. Bill of Materials

Component(s)	Value/Description	Supplier(s)
C1	Supply bypass capacitor, 22 nF, $\pm 20\%$ , Z5U/X7R	Murata
R1	GPO resistor, 1 k $\Omega$	Venkel
U1	Si4708/09 FM Radio Tuner	Silicon Laboratories

## 4. Functional Description

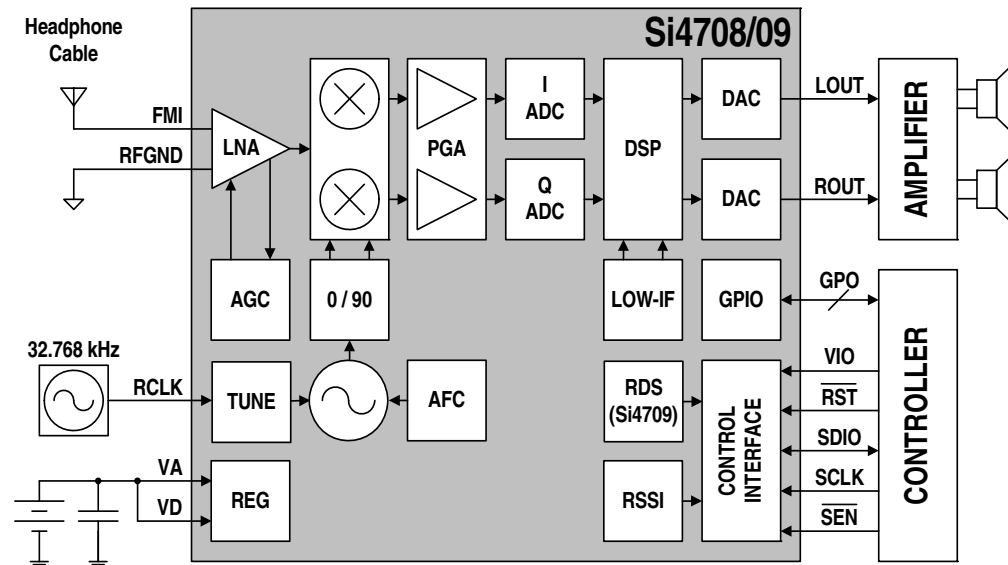

Figure 6. Si4708/09 FM Receiver Block Diagram

### 4.1. Overview

The Si4708/09 extends Silicon Laboratories Si4700 FM tuner family, and further increases the ease and attractiveness of adding FM radio reception to mobile devices through small size and board area, minimum component count, flexible programmability, and superior, proven performance. Si4708/09 software is backwards compatible to existing Si4700/01/02/03 FM Tuner designs and leverages Silicon Laboratories' highly successful and patented Si4700/01/02/03 FM tuner. The Si4708/09 benefits from proven digital integration and 100% CMOS process technology, resulting in a completely integrated solution. It is the industry's smallest footprint FM tuner IC requiring only 6.25 mm<sup>2</sup> board space and one external bypass capacitor.

The device offers significant programmability, catering to the subjective nature of FM listeners' audio preferences and variable FM broadcast environments worldwide.

The Si4709 incorporates a digital processor for the European Radio Data System (RDS) and the US Radio Broadcast Data System (RBDS) including all required symbol decoding, block synchronization, error detection, and error correction functions.

RDS/RBDS\* enables data such as station identification and song name to be displayed to the user. The Si4709 offers a detailed RDS view and a standard view, allowing adopters to selectively choose granularity of

RDS status, data, and block errors. Si4709 RDS software is backwards compatible to the proven Si4701/03, adopted by leading cell-phone and MP3 manufacturers world-wide.

The Si4708/09 is based on the superior, proven performance of Silicon Laboratories' Aero architecture offering unmatched interference rejection and leading sensitivity. The device uses the same programming interface as the Si4700/01/02/03 and supports multiple bus modes. Power management is simplified with an integrated regulator allowing direct connection to a 2.7 to 5.5 V battery for V<sub>D</sub> and 2.7 to 5.5 V battery for V<sub>A</sub>.

The Si4708/09 device's high level of integration and complete FM system production testing increases quality to manufacturers, improves device yields, and simplifies device manufacturing and final testing.

\***Note:** RDS/RBDS is referred to as RDS throughout the remainder of this document.

### 4.2. FM Receiver

The Si4708/09 architecture and antenna design increases system performance. To ensure proper performance and operation, designers should refer to the guidelines in "AN350: Si4708/09 Antenna, Schematic, Layout, and Design Guidelines". Conformance to these guidelines will help to ensure excellent performance in weak signal, noisy, and crowded signal environments where many strong channels are present.

The Si4708/09's patented digital low-IF architecture reduces external components and eliminates the need for factory adjustments. The receive (RX) section integrates a low noise amplifier (LNA) supporting the worldwide FM broadcast band (76 to 108 MHz). An automatic gain control (AGC) circuit controls the gain of the LNA to optimize sensitivity and rejection of strong interferers.

An image-reject mixer downconverts the RF signal to low-IF. The quadrature mixer output is amplified, filtered, and digitized with high resolution analog-to-digital converters (ADCs). This advanced architecture achieves superior performance by using digital signal processing (DSP) to perform channel selection, FM demodulation, and stereo audio processing compared to traditional analog architectures.

### 4.3. General Purpose Output

The GPO pin can serve multiple functions. After powerup of the device, the GPO pin can be used as a general purpose input/output, and can be used as an interrupt request pin for the seek/tune or RDS ready functions. See register 04h, bits [3:2] in Section "6. Register Descriptions" for information on GPO control. It is recommended that the GPO pin not be used as an interrupt request output until the powerup time has completed (see Section "4.9. Reset, Powerup, and Powerdown"). The GPO pin is powered from the  $V_{IO}$  supply; therefore, general purpose input/output functionality is available regardless of the state of the  $V_A$  and  $V_D$  supplies, or the ENABLE and DISABLE bits.

### 4.4. RDS/RBDS Processor and Functionality

The Si4709 implements an RDS/RBDS processor for symbol decoding, block synchronization, error detection, and error correction. RDS functionality is enabled by setting the RDS bit. The device offers two RDS modes, a standard mode and a verbose mode. The primary difference is increased visibility to RDS block-error levels and synchronization status with verbose mode.

Setting the RDS mode (RDSM) bit low places the device in standard RDS mode (default). The device will set the RDS ready (RDSR) bit for a minimum of 40 ms when a valid RDS group has been received. Setting the RDS interrupt enable (RDSIEN) bit and  $GPO[1:0] = 01$  will configure GPO to pulse low for a minimum of 5 ms when a valid RDS group has been received. If an invalid group is received, RDSR will not be set and GPO will not pulse low. In standard mode RDS synchronization (RDSS) and block error rate A, B, C and D (BLERA, BLERB, BLERC, and BLERD) are unused and will read 0. This mode is backward compatible with earlier firmware revisions.

Setting the RDS mode bit high places the device in RDS verbose mode. The device sets RDSS high when synchronized and low when synchronization is lost. If the device is synchronized, RDS ready (RDSR) will be set for a minimum of 40 ms when a RDS group has been received. Setting the RDS interrupt enable (RDSIEN) bit and  $GPO[1:0] = 01$  will configure GPO to pulse low for a minimum of 5 ms if the device is synchronized and an RDS group has been received. BLERA, BLERB, BLERC and BLERD provide block-error levels for the RDS group. The number of bit errors in each block within the group is encoded as follows: 00 = no errors, 01 = one to two errors, 10 = three to five errors, 11 = six or more errors. Six or more errors in a block indicate the block is uncorrectable and should not be used.

Setting the RDS mode bit high places the device in RDS verbose mode. The device sets RDSS high when synchronized and low when synchronization is lost. If the device is synchronized, RDS ready (RDSR) will be set for a minimum of 40 ms when a RDS group has been received. Setting the RDS interrupt enable (RDSIEN) bit and  $GPO[1:0] = 01$  will configure GPO to pulse low for a minimum of 5 ms if the device is synchronized and an RDS group has been received. BLERA, BLERB, BLERC and BLERD provide block-error levels for the RDS group. The number of bit errors in each block within the group is encoded as follows: 00 = no errors, 01 = one to two errors, 10 = three to five errors, 11 = six or more errors. Six or more errors in a block indicate the block is uncorrectable and should not be used.

### 4.5. Stereo Audio Processing

The output of the FM demodulator is a stereo multiplexed (MPX) signal. The MPX standard was developed in 1961 and is used worldwide. Today's MPX signal format consists of left + right (L+R) audio, left - right (L-R) audio, a 19 kHz pilot tone, and RDS/RBDS data as shown in Figure 7.

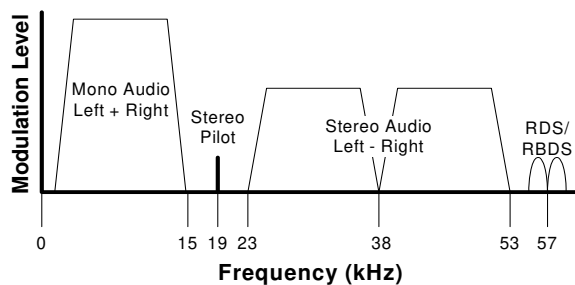

**Figure 7. MPX Signal Spectrum**

The Si4708/09's integrated stereo decoder automatically decodes the MPX signal. The 0 to 15 kHz (L+R) signal is the mono output of the FM tuner. Stereo is generated from the (L+R), (L-R), and a 19 kHz pilot tone. The pilot tone is used as a reference to recover the (L-R) signal. Separate left and right channels are obtained by adding and subtracting the (L+R) and (L-R) signals, respectively. The Si4709 uses frequency information from the 19 kHz stereo pilot to recover the 57 kHz RDS/RBDS signal.

Adaptive noise suppression is employed to gradually combine the stereo left and right audio channels to a mono (L+R) audio signal as the signal quality degrades



to maintain optimum sound fidelity under varying reception conditions. The signal level range over which the stereo to mono blending occurs can be adjusted by setting the BLNDADJ[1:0] register. Stereo/mono status can be monitored with the ST register bit and mono operation can be forced with the MONO register bit.

Pre-emphasis and de-emphasis is a technique used by FM broadcasters to improve the signal-to-noise ratio of FM receivers by reducing the effects of high frequency interference and noise. When the FM signal is transmitted, a pre-emphasis filter is applied to accentuate the high audio frequencies. All FM receivers incorporate a de-emphasis filter which attenuates high frequencies to restore a flat frequency response. Two time constants, 50 or 75  $\mu$ s, are used in various regions. The de-emphasis time constant is programmable with the DE bit.

High-fidelity stereo digital-to-analog converters (DACs) drive analog audio signals onto the LOUT and ROUT pins. The audio output may be muted with the DMUTE bit. Volume can be adjusted digitally with the VOLUME[3:0] bits. The volume dynamic range can be set to either -28 dBFS (default) or -58 dBFS by setting VOEXT=1.

The soft mute feature is available to attenuate the audio outputs and minimize audible noise in very weak signal conditions. The soft mute attack and decay rate can be adjusted with the SMUTER[1:0] bits where 00 is the fastest setting. The soft mute attenuation level can be adjusted with the SMUTEA[1:0] bits where 00 is the most attenuated. The soft mute disable (DSMUTE) bit may be set high to disable this feature.

#### 4.6. Tuning

The Si4708/09 uses Silicon Laboratories' patented and proven frequency synthesizer technology including a completely integrated VCO. The frequency synthesizer generates the quadrature local oscillator signal used to downconvert the RF input to a low intermediate frequency. The VCO frequency is locked to the reference clock and adjusted with an automatic frequency control (AFC) servo loop during reception.

The tuning frequency is defined as:

$$\text{Freq (MHz)} = \text{Spacing (kHz)} \times \text{Channel} + \text{Bottom of Band (MHz)}$$

Channel spacing of 50, 100 or 200 KHz is selected with bits SPACE[1:0]. The channel is selected with bits CHAN[9:0]. The bottom of the band is set to 76 MHz or 87.5 MHz with the bits BAND[1:0]. The tuning operation begins by setting the TUNE bit. After tuning completes, the seek/tune complete (STC) bit will be set and the RSSI level is available by reading bits RSSI[7:0]. The TUNE bit must be set low after the STC bit is set high in

order to complete the tune operation and clear the STC bit.

Seek tuning searches up or down for a channel with an RSSI greater than or equal to the seek threshold set with the SEEKTH[7:0] bits. In addition, an optional SNR and/or impulse noise detector may be used to qualify valid stations. The SKSNR[3:0] bits set the SNR threshold required. The SKCNT[3:0] bits set the impulse noise threshold. Using the extra seek qualifiers can reduce false stops and, in combination with lowering the RSSI seek threshold, increase the number of found stations. The SNR and impulse noise detectors are disabled by default.

Two seek modes are available. When the seek mode (SKMODE) bit is low and a seek is initiated, the device seeks through the band, wraps from one band edge to the other, and continues seeking. If the seek operation was unable to find a channel, the seek failure/band limit (SF/BL) bit will be set high and the device will return to the channel selected before the seek operation began. When the SKMODE bit is high and a seek is initiated, the device seeks through the band until the band limit is reached and the SF/BL bit will be set high. A seek operation is initiated by setting the SEEK and SEEKUP bits. After the seek operation completes, the STC bit will be set, and the RSSI level and tuned channel are available by reading bits RSSI[7:0] and bits READCHAN[9:0]. During a seek operation READCHAN[9:0] is also updated and may be read to determine seek progress. The STC bit will be set after the seek operation completes. The channel is valid if the seek operation completes and the SF/BL bit is set low. At other times, such as before a seek operation or after a seek completes and the SF/BL bit is set high, the channel is valid if the AFC Rail (AFCRL) bit is set low and the value of RSSI[7:0] is greater than or equal to SEEKTH[7:0]. Note that if the AFCRL bit is set, the audio output is muted as in the softmute case discussed in Section "4.5. Stereo Audio Processing". The SEEK bit must be set low after the STC bit is set high in order to complete the seek operation and clear the STC and SF/BL bits. The seek operation may be aborted by setting the SEEK bit low at any time.

The device can be configured to generate an interrupt on GPO when a tune or seek operation completes. Setting the seek/tune complete (STCIEN) bit and GPO[1:0]=01 will configure GPO for a 5 ms low interrupt when the STC bit is set by the device.

For additional recommendations on optimizing the seek function, consult "AN349: Si4708/09 Programming Guide."

## 4.7. Reference Clock

The Si4708/09-B accepts a 32.768 kHz reference clock to the RCLK pin. The reference clock is required whenever the ENABLE bit is set high. Refer to Table 3, "DC Characteristics<sup>1</sup>," on page 5 for input switching voltage levels and Table 7, "FM Receiver Characteristics," on page 10 for frequency tolerance information.

## 4.8. Control Interface

Two-wire slave-transceiver and three-wire interfaces are provided for the controller IC to read and write the control registers. Refer to "4.9. Reset, Powerup, and Powerdown" for a description of bus mode selection. Registers may be written and read when the  $V_{IO}$  supply is applied regardless of the state of the  $V_D$  or  $V_A$  supplies. RCLK is not required for proper register operation.

### 4.8.1. 3-Wire Control Interface

For three-wire operation, a transfer begins when the SEN pin is sampled low by the device on a rising SCLK edge. The control word is latched internally on rising SCLK edges and is nine bits in length, comprised of a four bit chip address  $A7:A4 = 0110b$ , a read/write bit (write = 0 and read = 1), and a four bit register address,  $A3:A0$ . The ordering of the control word is  $A7:A5$ , R/W,  $A4:A0$ . Refer to Section 5, "Register Summary" on page 19 for a list of all registers and their addresses.

For write operations, the serial control word is followed by a 16-bit data word and is latched internally on rising SCLK edges.

For read operations, a bus turn-around of half a cycle is followed by a 16-bit data word shifted out on rising SCLK edges and is clocked into the system controller on falling SCLK edges. The transfer ends on the rising SCLK edge after SEN is set high. Note that 26 SCLK cycles are required for a transfer, however, SCLK may run continuously.

For details on timing specifications and diagrams, refer to Table 5, "3-Wire Control Interface Characteristics," on page 7, Figure 2, "3-Wire Control Interface Write Timing Parameters," on page 7, and Figure 3, "3-Wire Control Interface Read Timing Parameters," on page 7.

### 4.8.2. 2-Wire Control Interface

For two-wire operation, the SCLK and SDIO pins function in open-drain mode (pull-down only) and must be pulled up by an external device. A transfer begins with the START condition (falling edge of SDIO while SCLK is high). The control word is latched internally on rising SCLK edges and is eight bits in length, comprised of a seven bit device address equal to 0010000b and a read/write bit (write = 0 and read = 1).

The device acknowledges the address by driving SDIO low after the next falling SCLK edge, for 1 cycle. For write operations, the device acknowledge is followed by an eight bit data word latched internally on rising edges of SCLK. The device acknowledges each byte of data written by driving SDIO low after the next falling SCLK edge, for 1 cycle. An internal address counter automatically increments to allow continuous data byte writes, starting with the upper byte of register 02h, followed by the lower byte of register 02h, and onward until the lower byte of the last register is reached. The internal address counter then automatically wraps around to the upper byte of register 00h and proceeds from there until continuous writes end. Data transfer ends with the STOP condition (rising edge of SDIO while SCLK is high). After every STOP condition, the internal address counter is reset.

For read operations, the device acknowledge is followed by an eight bit data word shifted out on falling SCLK edges. An internal address counter automatically increments to allow continuous data byte reads, starting with the upper byte of register 0Ah, followed by the lower byte of register 0Ah, and onward until the lower byte of the last register is reached. The internal address counter then automatically wraps around to the upper byte of register 00h and proceeds from there until continuous reads cease. After each byte of data is read, the controller IC must drive an acknowledge ( $SDIO = 0$ ) if an additional byte of data will be requested. Data transfer ends with the STOP condition. After every STOP condition, the internal address counter is reset.

For details on timing specifications and diagrams, refer to Table 6, "2-Wire Control Interface Characteristics<sup>1,2,3</sup>," on page 8, Figure 4, "2-Wire Control Interface Read and Write Timing Parameters," on page 9 and Figure 5, "2-Wire Control Interface Read and Write Timing Diagram," on page 9.

## 4.9. Reset, Powerup, and Powerdown

Driving the  $\overline{RST}$  pin low will disable the Si4708/09 and its control bus interface, and reset the registers to their default settings. Driving the RST pin high will bring the device out of reset. As the part is brought out of reset, the SEN pin is used to select between 2-wire and 3-wire control interface operation.

**Table 8. Selecting 2-Wire or 3-Wire Control Interface Busmode Operation**

Bus Mode	$\overline{\text{SEN}}$
3-wire	0
2-wire	1

**Note:** All parameters applied on rising edge of  $\overline{\text{RST}}$ .

The bus mode selection method requires the use of the SEN pin. To select 2-wire operation, the SEN pin must be sampled high by the device on the rising edge of RST. To select 3-wire operation, the SEN pin must be sampled low by the device on the rising edge of RST.

When proper voltages are applied to the Si4708/09, the ENABLE and DISABLE bits in register 02h can be used to select between powerup and powerdown modes. When voltage is first applied to the device, ENABLE = DISABLE = 0. Setting ENABLE = 1 and DISABLE = 0 puts the device in powerup mode. To power down the device, disable RDS (Si4709 only), set Reg4(5:4), Reg4(3:2), and Reg4(1:0) to 0b10. then write 1 to the ENABLE and DISABLE bits. After being written to 1, both bits will get cleared as part of the internal device powerdown sequence. To put the device back into powerup mode, set ENABLE = 1 and DISABLE = 0 as described above. The ENABLE bit should never be written to a 0.

#### 4.10. Audio Output Summation

The audio outputs LOUT and ROUT may be capacitively summed with another device. Setting the audio high-Z enable (AHIZEN) bit maintains a dc bias of  $0.5 \times V_{IO}$  on the LOUT and ROUT pins to prevent the ESD diodes from clamping to the  $V_{IO}$  or GND rail in response to the output swing of the other device. The bias point is set with a 370 k $\Omega$  resistor to  $V_{IO}$  and GND. Register 07h containing the AHIZEN bit must not be written during the powerup sequence and only takes effect when in powerdown and  $V_{IO}$  is supplied. In powerup the LOUT and ROUT pins are set to the common mode voltage specified in Table 7, "FM Receiver Characteristics<sup>1,2</sup>," on page 10, regardless of the state of AHIZEN. Bits 13:0 of register 07h must be preserved as 0x0100 while in powerdown and as 0x3C04 while in powerup.

#### 4.11. Initialization Sequence

Refer to Figure 8, "Initialization Sequence," on page 18.

To initialize the device:

1. Supply  $V_A$  and  $V_D$ .
2. Supply  $V_{IO}$  while keeping the  $\overline{\text{RST}}$  pin low. Note that steps 1 and 2 may be reversed. Power supplies may be sequenced in any order.
3. Select 2-wire or 3-wire control interface bus mode operation as described in Section 4.9. "Reset, Powerup, and Powerdown" on page 16.
4. Provide RCLK. Steps 3 and 4 may be reversed when using an external oscillator.
5. Set the ENABLE bit high and the DISABLE bit low to powerup the device. Software should wait for the powerup time (as specified by Table 7, "FM Receiver Characteristics<sup>1,2</sup>," on page 10) before continuing with normal part operation.

To power down the device:

1. (Optional) Set the AHIZEN bit high to maintain a dc bias of  $0.5 \times V_{IO}$  volts at the LOUT and ROUT pins while in powerdown, but preserve the states of the other bits in Register 07h. Note that in powerup the LOUT and ROUT pins are set to the common mode voltage specified in Table 7 on page 10, regardless of the state of AHIZEN.
2. Set the ENABLE bit high and the DISABLE bit high to place the device in powerdown mode. Note that all register states are maintained so long as  $V_{IO}$  is supplied and the RST pin is high.
3. (Optional) Remove RCLK.
4. Remove  $V_A$  and  $V_D$  supplies as needed.

To power up the device (after power down):

1. Note that  $V_{IO}$  is still supplied in this scenario. If  $V_{IO}$  is not supplied, refer to device initialization procedure above.
2. (Optional) Set the AHIZEN bit low to disable the dc bias of  $0.5 \times V_{IO}$  volts at the LOUT and ROUT pins, but preserve the states of the other bits in Register 07h. Note that in powerup the LOUT and ROUT pins are set to the common mode voltage specified in Table 7 on page 10, regardless of the state of AHIZEN.
3. Supply  $V_A$  and  $V_D$ .
4. Provide RCLK. Steps 3 and 4 may be reversed when using an external oscillator.
5. Set the ENABLE bit high and the DISABLE bit low to powerup the device. Software should wait for the powerup time (as specified by Table 7, "FM Receiver Characteristics<sup>1,2</sup>," on page 10) before continuing with normal part operation.

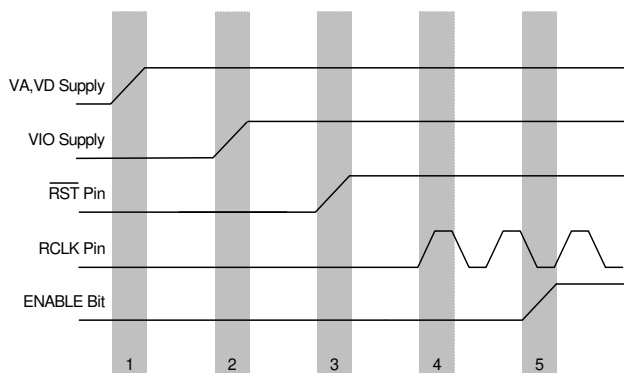

**Figure 8. Initialization Sequence**

## 4.12. Programming Guide

Refer to "AN349: Si4708/09 Programming Guide" for control interface programming information.

Confidential

## 5. Register Summary

Reg <sup>1</sup>	Name	D15	D14	D13	D12	D11	D10	D9	D8	D7	D6	D5	D4	D3	D2	D1	D0
00h	DEVICEID	PN[3:0]				MFGID[11:0]											
01h	CHIPID	REV[5:0]						DEV[3:0]				FIRMWARE[5:0]					
02h	POWERCFG	DSMUTE	DMUTE	MONO	0	RDSM <sup>2</sup>	SKMODE	SEEKUP	SEEK	0	DISABLE	0	0	0	0	0	ENABLE
03h	CHANNEL	TUNE	0	0	0	0	0	CHAN[9:0]									
04h	SYSCONFIG1	RDSIEN <sup>2</sup>	STCIEN	0	RDS <sup>2</sup>	DE	AGCD	0	0	BLNDADJ[1:0]		1	0	GPO[1:0]		1	0
05h	SYSCONFIG2	SEEKTH[7:0]							BAND[1:0]		SPACE[1:0]		VOLUME[3:0]				
06h	SYSCONFIG3	SMUTER[1:0]		SMUTEA[1:0]				0	VOLEXT	SKSNR[3:0]			SKCNT[3:0]				
07h	TEST1	0	AHIZEN														
08h	TEST2																
09h	BOOTCONFIG																
0Ah	STATUSRSSI	RDSR <sup>2</sup>	STC	SF/BL	AFCRL	RDSS <sup>2,3</sup>	BLERA[1:0] <sup>2,3</sup>		ST	RSSI[7:0]							
0Bh	READCHAN	BLERB[1:0] <sup>2,3</sup>		BLERC[1:0] <sup>2,3</sup>		BLERD[1:0] <sup>2,3</sup>			READCHAN[9:0]								
0Ch	RDSA	RDSA[15:0] <sup>2</sup>															
0Dh	RDSB	RDSB[15:0] <sup>2</sup>															
0Eh	RDSC	RDSC[15:0] <sup>2</sup>															
0Fh	RSD	RSD[15:0] <sup>2</sup>															

### Notes:

- Any register not listed is reserved and should not be written. Writing to reserved registers may result in unpredictable behavior.
- Si4709 only.
- Available in RDS verbose mode only.

# Si4708/09-B

## 6. Register Descriptions

### Register 00h. Device ID

Bit	D15	D14	D13	D12	D11	D10	D9	D8	D7	D6	D5	D4	D3	D2	D1	D0
Name	PN[3:0]					MFGID[11:0]										
Type	R					R										

Reset value = 0x1242

Bit	Name	Function
15:12	PN[3:0]	<b>Part Number.</b> 0x01 = Si4708/09
11:0	MFGID[11:0]	<b>Manufacturer ID.</b> 0x242

### Register 01h. Chip ID

Bit	D15	D14	D13	D12	D11	D10	D9	D8	D7	D6	D5	D4	D3	D2	D1	D0
Name	REV[5:0]					DEV[3:0]			FIRMWARE[5:0]							
Type	R					R			R							

Si4708B Reset value = 0x1093 if ENABLE = 1

Si4708B Reset value = 0x1000 if ENABLE = 0

Si4709B Reset value = 0x1293 if ENABLE = 1

Si4709B Reset value = 0x1200 if ENABLE = 0

Bit	Name	Function
15:10	REV[5:0]	<b>Chip Version.</b> 0x04 = Rev B
9:6	DEV[3:0]	<b>Device.</b> 0000 before powerup = Si4708. 1000 before powerup = Si4709. 0010 after powerup = Si4708. 1010 after powerup = Si4709.
5:0	FIRMWARE[5:0]	<b>Firmware Version.</b> 0 before powerup. Firmware version after powerup = 010011.

**Register 02h. Power Configuration**

Bit	D15	D14	D13	D12	D11	D10	D9	D8	D7	D6	D5	D4	D3	D2	D1	D0
<b>Name</b>	DSMUTE	DMUTE	MONO	0	RDSM	SKMODE	SEEKUP	SEEK	0	DISABLE	0	0	0	0	0	ENABLE
<b>Type</b>	R/W	R/W	R/W	R/W	R/W	R/W	R/W	R/W	R/W	R/W	R/W	R/W	R/W	R/W	R/W	R/W

Reset value = 0x0000

Bit	Name	Function
15	DSMUTE	<b>Softmute Disable.</b> 0 = Softmute enable (default). 1 = Softmute disable.
14	DMUTE	<b>Mute Disable.</b> 0 = Mute enable (default). 1 = Mute disable.
13	MONO	<b>Mono Select.</b> 0 = Stereo (default). 1 = Force mono.
12	Reserved	<b>Reserved.</b> Always write to 0.
11	RDSM	<b>RDS Mode (Si4709 only).</b> 0 = Standard (default). 1 = Verbose. Refer to "4.4. RDS/RBDS Processor and Functionality".
10	SKMODE	<b>Seek Mode.</b> 0 = Wrap at the upper or lower band limit and continue seeking (default). 1 = Stop seeking at the upper or lower band limit.
9	SEEKUP	<b>Seek Direction.</b> 0 = Seek down (default). 1 = Seek up.
8	SEEK	<b>Seek.</b> 0 = Disable (default). 1 = Enable. <b>Notes:</b> <ol style="list-style-type: none"> <li>1. Seek begins at the current channel, and goes in the direction specified with the SEEKUP bit. Seek operation stops when a channel is qualified as valid according to the seek parameters, the entire band has been searched (SKMODE = 0), or the upper or lower band limit has been reached (SKMODE = 1).</li> <li>2. The STC bit is set high when the seek operation completes and/or the SF/BL bit is set high if the seek operation was unable to find a channel qualified as valid according to the seek parameters. The STC and SF/BL bits must be set low by setting the SEEK bit low before the next seek or tune may begin.</li> <li>3. Seek performance for 50 kHz channel spacing varies according to RCLK tolerance. Silicon Laboratories recommends <math>\pm 50</math> ppm RCLK crystal tolerance for 50 kHz seek performance.</li> <li>4. A seek operation may be aborted by setting SEEK = 0.</li> </ol>



# Si4708/09-B

Bit	Name	Function
7	Reserved	<b>Reserved.</b> Always write to 0.
6	DISABLE	<b>Powerup Disable.</b> Refer to “4.9. Reset, Powerup, and Powerdown”. Default = 0.
5:1	Reserved	<b>Reserved.</b> Always write to 0.
0	ENABLE	<b>Powerup Enable.</b> Refer to “4.9. Reset, Powerup, and Powerdown”. Default = 0.

## Register 03h. Channel

Bit	D15	D14	D13	D12	D11	D10	D9	D8	D7	D6	D5	D4	D3	D2	D1	D0
<b>Name</b>	TUNE	0	0	0	0	0	CHANNEL[9:0]									
<b>Type</b>	R/W	R/W	R/W	R/W	R/W	R/W	R/W									

Reset value = 0x0000

Bit	Name	Function
15	TUNE	<b>Tune.</b> 0 = Disable (default). 1 = Enable. The tune operation begins when the TUNE bit is set high. The STC bit is set high when the tune operation completes. The STC bit must be set low by setting the TUNE bit low before the next tune or seek may begin.
14:10	Reserved	<b>Reserved.</b> Always write to 0.
9:0	CHAN[9:0]	<b>Channel Select.</b> Channel value for tune operation. If BAND 05h[7:6] = 00, then Freq (MHz) = Spacing (kHz) x Channel + 87.5 MHz. If BAND 05h[7:6] = 01, BAND 05h[7:6] = 10, then Freq (MHz) = Spacing (kHz) x Channel + 76 MHz. CHAN[9:0] is not updated during a seek operation. READCHAN[9:0] provides the current tuned channel and is updated during a seek operation and after a seek or tune operation completes. Channel spacing is set with the bits SPACE 05h[5:4].

**Register 04h. System Configuration 1**

Bit	D15	D14	D13	D12	D11	D10	D9	D8	D7	D6	D5	D4	D3	D2	D1	D0
<b>Name</b>	RDSIEN	STCIEN	0	RDS	DE	AGCD	0	0	BLNDADJ[1:0]		0	0	GPO[1:0]		0	0
<b>Type</b>	R/W	R/W	R/W	R/W	R/W	R/W	R/W	R/W	R/W	R/W	R/W	R/W	R/W	R/W	R/W	R/W

Reset value = 0x0000

Bit	Name	Function
15	RDSIEN	<b>RDS Interrupt Enable (Si4709 only).</b> 0 = Disable Interrupt (default). 1 = Enable Interrupt. Setting RDSIEN = 1 and GPO[1:0] = 01 will generate a 5 ms low pulse on GPO when the RDSR 0Ah[15] bit is set.
14	STCIEN	<b>Seek/Tune Complete Interrupt Enable.</b> 0 = Disable Interrupt (default). 1 = Enable Interrupt. Setting STCIEN = 1 and GPO[1:0] = 01 will generate a 5 ms low pulse on GPO when the STC 0Ah[14] bit is set.
13	Reserved	<b>Reserved.</b> Always write to 0.
12	RDS	<b>RDS Enable (Si4709 only).</b> 0 = Disable (default). 1 = Enable.
11	DE	<b>De-emphasis.</b> 0 = 75 $\mu$ s. Used in USA (default). 1 = 50 $\mu$ s. Used in Europe, Australia, Japan.
10	AGCD	<b>AGC Disable.</b> 0 = AGC enable (default). 1 = AGC disable.
9:8	Reserved	<b>Reserved.</b> Always write to 0.
7:6	BLNDADJ[1:0]	<b>Stereo/Mono Blend Level Adjustment.</b> Sets the RSSI range for stereo/mono blend. 00 = 31–49 RSSI dB $\mu$ V (default). 01 = 37–55 RSSI dB $\mu$ V (+6 dB). 10 = 19–37 RSSI dB $\mu$ V (–12 dB). 11 = 25–43 RSSI dB $\mu$ V (–6 dB). ST bit set for RSSI values greater than low end of range.
5:4	Reserved	<b>Reserved.</b> Always write to 10.

## Si4708/09-B

---

Bit	Name	Function
3:2	GPO[1:0]	<b>General Purpose I/O.</b> 00 = High impedance (default). 01 = STC/RDS interrupt. A logic high will be output unless an interrupt occurs as described below. 10 = Low. 11 = High. Setting STCIEN = 1 will generate a 5 ms low pulse on GPO when the STC 0Ah[14] bit is set. Setting RDSIEN = 1 will generate a 5 ms low pulse on GPO when the RDSR 0Ah[15] bit is set.
1:0	Reserved	<b>Reserved.</b> Always write to 10.

Confidential

**Register 05h. System Configuration 2**

Bit	D15	D14	D13	D12	D11	D10	D9	D8	D7	D6	D5	D4	D3	D2	D1	D0
<b>Name</b>	SEEKTH[7:0]							BAND[1:0]		SPACE[1:0]		VOLUME[3:0]				
<b>Type</b>	R/W							R/W		R/W		R/W				

Reset value = 0x0000

Bit	Name	Function
15:8	SEEKTH[7:0]	<p><b>RSSI Seek Threshold.</b>            0x00 = min RSSI (default).            0x7F = max RSSI.            SEEKTH presents the logarithmic RSSI threshold for the seek operation. The Si4708/09 will not validate channels with RSSI below the SEEKTH value. SEEKTH is one of multiple parameters that can be used to validate channels. For more information, see "AN349: Si4708/09 Programming Guide."</p>
7:6	BAND[1:0]	<p><b>Band Select.</b>            00 = 87.5–108 MHz (US/Europe, Default).            01 = 76–108 MHz (Japan wide band).            10 = 76–90 MHz (Japan).            11 = Reserved.</p>
5:4	SPACE[1:0]	<p><b>Channel Spacing.</b>            00 = 200 kHz (USA, Australia) (default).            01 = 100 kHz (Europe, Japan).            10 = 50 kHz.</p>
3:0	VOLUME[3:0]	<p><b>Volume.</b>            Relative value of volume is shifted –30 dBFS with the VOLEXT 06h[8] bit.            VOLEXT = 0 (default).            0000 = mute (default).            0001 = –28 dBFS.            :            :            1110 = –2 dBFS.            1111 = 0 dBFS.</p> <p>VOLEXT = 1.            0000 = mute.            0001 = –58 dBFS.            :            :            1110 = –32 dBFS.            1111 = –30 dBFS.            FS = full scale.            Volume scale is logarithmic.</p>