



Chipsmall Limited consists of a professional team with an average of over 10 year of expertise in the distribution of electronic components. Based in Hongkong, we have already established firm and mutual-benefit business relationships with customers from,Europe,America and south Asia,supplying obsolete and hard-to-find components to meet their specific needs.

With the principle of "Quality Parts,Customers Priority,Honest Operation,and Considerate Service",our business mainly focus on the distribution of electronic components. Line cards we deal with include Microchip,ALPS,ROHM,Xilinx,Pulse,ON,Everlight and Freescale. Main products comprise IC,Modules,Potentiometer,IC Socket,Relay,Connector.Our parts cover such applications as commercial,industrial, and automotives areas.

We are looking forward to setting up business relationship with you and hope to provide you with the best service and solution. Let us make a better world for our industry!



Contact us

Tel: +86-755-8981 8866 Fax: +86-755-8427 6832

Email & Skype: info@chipsmall.com Web: www.chipsmall.com

Address: A1208, Overseas Decoration Building, #122 Zhenhua RD., Futian, Shenzhen, China



FM RADIO TRANSMITTER WITH RECEIVE POWER SCAN

Features

- Integrated receive power measurement
- Worldwide FM band support (76–108 MHz)
- Requires only two external components
- Frequency synthesizer with integrated VCO
- Digital stereo modulator
- Programmable pre-emphasis
- Analog/digital audio interface
- Audio silence detector
- Programmable reference clock
- RDS/RBDS encoder (Si4713 only)
- PCB loop and stub antenna support with self-calibrated capacitor tuning
- Programmable transmit level
- Audio dynamic range control
- Advanced modulation control
- 2.7 to 5.5 V supply voltage
- Integrated LDO regulator
- 3 x 3 x 0.55 mm 20-pin QFN
 - Pb-free and RoHS Compliant
- Designed for compatibility with cellular operation

Applications

- Cellular handsets/hands-free
- MP3 players
- Portable media players
- Wireless speakers/microphone
- Satellite digital audio radios
- Personal computers/notebooks

Description

The Si4712/13-B30 integrates the complete transmit functions for standards-compliant unlicensed FM broadcast stereo transmission. The chip also allows integrated receive power scanning to identify low signal power FM channels. Users must comply with local regulations on radio frequency (RF) transmission.

Functional Block Diagram

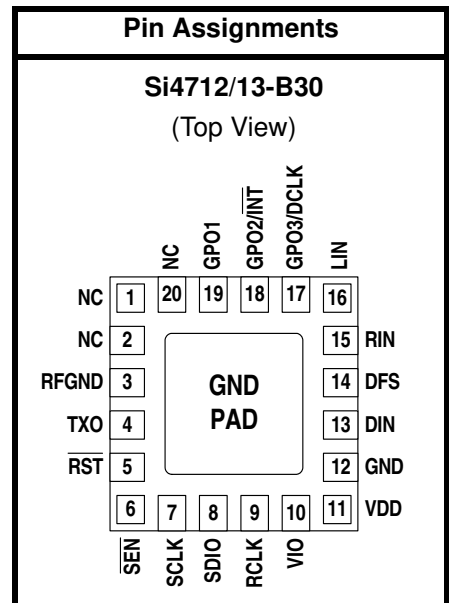
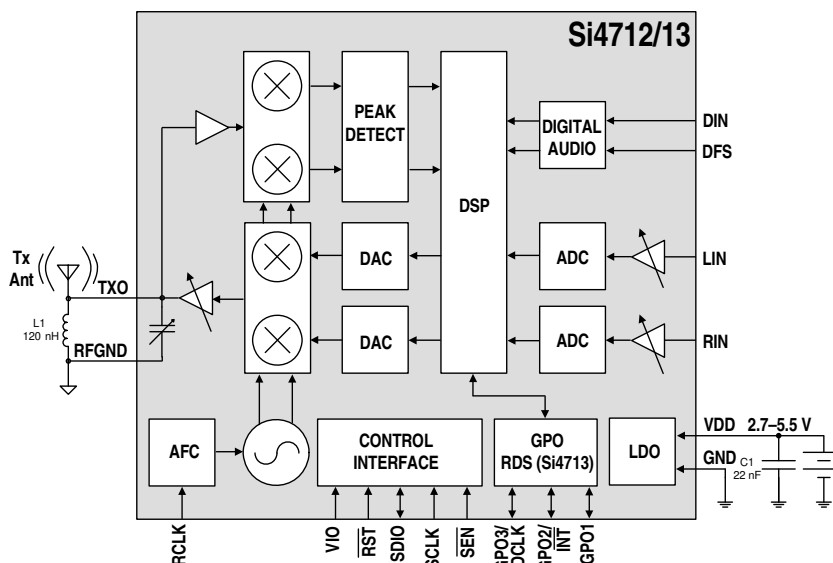

Patents pending

Note: To ensure proper operation and performance, follow the guidelines in “AN383: Universal Antenna Selection and Layout Guidelines.” Silicon Laboratories will evaluate schematics and layouts for qualified customers.

TABLE OF CONTENTS

<u>Section</u>	<u>Page</u>
1. Electrical Specifications	4
2. Test Circuit	15
2.1. Test Circuit Schematic	15
2.2. Test Circuit Bill of Materials	15
3. Typical Application Schematics	16
3.1. Analog Audio Inputs	16
3.2. Digital Audio Inputs	17
3.3. Typical Application Schematic Bill of Materials	17
4. Universal AM/FM RX/FM TX Application Schematic	18
4.1. Universal AM/FM RX/FM TX Bill of Materials	19
5. Functional Description	20
5.1. Overview	20
5.2. FM Transmitter	21
5.3. Receive Power Scan	21
5.4. Digital Audio Interface	23
5.5. Line Input	25
5.6. Audio Dynamic Range Control	26
5.7. Audio Limiter	26
5.8. Pre-emphasis and De-emphasis	27
5.9. RDS/RBDS Processor (Si4713 Only)	27
5.10. Tuning	27
5.11. Reference Clock	27
5.12. Control Interface	27
5.13. GPO Outputs	29
5.14. Reset, Powerup, and Powerdown	29
5.15. Programming with Commands	29
6. Commands and Properties	30
7. Pin Descriptions: Si4712/13-GM	33
8. Ordering Guide	34
9. Package Markings (Top Marks)	35
9.1. Si4712 Top Mark	35
9.2. Si4713 Top Mark	35
9.3. Top Mark Explanation	35
10. Package Outline: Si4712/13-GM	36
11. PCB Land Pattern: Si4712/13-GM	37
12. Additional Reference Resources	39
Document Change List	40
Contact Information	42

Si4712/13-B30

1. Electrical Specifications

Table 1. Recommended Operating Conditions

Parameter	Symbol	Test Condition	Min	Typ	Max	Unit
Supply Voltage	V_{DD}		2.7	—	5.5	V
Interface Supply Voltage	V_{IO}		1.5	—	3.6	V
Power Supply Powerup Rise Time	V_{DDRISE}		10	—	—	μ s
Interface Supply Powerup Rise Time	V_{IORISE}		10	—	—	μ s
Ambient Temperature	T_A		-20	25	85	$^{\circ}$ C

Note: All minimum and maximum specifications are guaranteed and apply across the recommended operating conditions. Typical values apply at $V_{DD} = 3.3$ V and 25 $^{\circ}$ C unless otherwise stated. Parameters are tested in production unless otherwise stated.

Table 2. Absolute Maximum Ratings^{1,2}

Parameter	Symbol	Value	Unit
Supply Voltage	V_{DD}	-0.5 to 5.8	V
Interface Supply Voltage	V_{IO}	-0.5 to 3.9	V
Input Current ³	I_{IN}	10	mA
Input Voltage ³	V_{IN}	-0.3 to ($V_{IO} + 0.3$)	V
Operating Temperature	T_{OP}	-40 to 95	$^{\circ}$ C
Storage Temperature	T_{STG}	-55 to 150	$^{\circ}$ C
RF Input Level ⁴		0.4	V_{PK}

Notes:

1. Permanent device damage may occur if the absolute maximum ratings are exceeded. Functional operation should be restricted to the conditions as specified in the operational sections of this data sheet. Exposure beyond recommended operating conditions for extended periods may affect device reliability.
2. The Si4712/13 devices are high-performance RF integrated circuits with certain pins having an ESD rating of < 2 kV HBM. Handling and assembly of these devices should only be done at ESD-protected workstations.
3. For input pins SCLK, SEN, SDIO, RST, RCLK, DCLK, DFS, DIN, GPO1, GPO2/INT, and GPO3.
4. At RF input pin, TXO.

Table 3. DC Characteristics

Test conditions: $V_{RF} = 118 \text{ dB}\mu\text{V}$, stereo, $\Delta f = 68.25 \text{ kHz}$, $\Delta f_{\text{pilot}} = 6.75 \text{ kHz}$, $\text{REFCLK} = 32.768 \text{ kHz}$, unless otherwise specified.

Production test conditions: $V_{DD} = 3.3 \text{ V}$, $V_{IO} = 3.3 \text{ V}$, $T_A = 25 \text{ }^\circ\text{C}$, $F_{RF} = 98 \text{ MHz}$.

Characterization test conditions: $V_{DD} = 2.7 \text{ to } 5.5 \text{ V}$, $V_{IO} = 1.5 \text{ to } 3.6 \text{ V}$, $T_A = -20 \text{ to } 85 \text{ }^\circ\text{C}$, $F_{RF} = 76\text{--}108 \text{ MHz}$.

Parameter	Symbol	Test Condition	Min	Typ	Max	Unit
FM Transmitter from Line Input						
TX Supply Current	I_{TX}		—	18.8	22.8	mA
TX Interface Supply Current	I_{IO}		—	320	600	μA
FM Transmitter from Digital Audio Input						
TX Supply Current	I_{DTX}	DCLK = 3.072 MHz	—	18.3	—	mA
TX Interface Supply Current	I_{DIO}	DCLK = 3.072 MHz	—	320	—	μA
FM Transmitter in Receive Power Scan Mode						
RX Supply Current	I_{RX}		—	16.8	—	mA
RX Interface Supply Current	I_{IO}		—	320	—	μA
Supplies and Interface						
V_{DD} Powerdown Current	I_{DD}	Powerdown mode	—	10	20	μA
V_{IO} Interface Powerdown Current	I_{IO}	SCLK, RCLK inactive Powerdown mode	—	3	10	μA
High Level Input Voltage ¹	V_{IH}		$0.7 \times V_{IO}$	—	$V_{IO} + 0.3$	V
Low Level Input Voltage ¹	V_{IL}		-0.3	—	$0.3 \times V_{IO}$	V
High Level Input Current ¹	I_{IH}	$V_{IN} = V_{IO} = 3.6 \text{ V}$	-10	—	10	μA
Low Level Input Current ¹	I_{IL}	$V_{IN} = 0 \text{ V}$, $V_{IO} = 3.6 \text{ V}$	-10	—	10	μA
High Level Output Voltage ²	V_{OH}	$I_{OUT} = 500 \mu\text{A}$	$0.8 \times V_{IO}$	—	—	V
Low Level Output Voltage ²	V_{OL}	$I_{OUT} = -500 \mu\text{A}$	—	—	$0.2 \times V_{IO}$	V
Notes:						
1. For input pins SCLK, SEN, SDIO, RST, RCLK, DCLK, DFS, DIN, GPO1, GPO2/ $\overline{\text{INT}}$, and GPO3.						
2. For output pins SDIO, GPO1, GPO2/ $\overline{\text{INT}}$, and GPO3.						

Si4712/13-B30

Table 4. Reset Timing Characteristics^{1,2,3}

($V_{DD} = 2.7$ to 5.5 V, $V_{IO} = 1.5$ to 3.6 V, $T_A = -20$ to 85 °C)

Parameter	Symbol	Min	Typ	Max	Unit
\overline{RST} Pulse Width and GPO1, GPO2/ \overline{INT} Setup to $\overline{RST}\uparrow^4$	t_{SRST}	100	—	—	μs
GPO1, GPO2/ \overline{INT} Hold from $\overline{RST}\uparrow$	t_{HRST}	30	—	—	ns

Important Notes:

1. When selecting 2-wire mode, the user must ensure that a 2-wire start condition (falling edge of SDIO while SCLK is high) does not occur within 300 ns before the rising edge of \overline{RST} .
2. When selecting 2-wire mode, the user must ensure that SCLK is high during the rising edge of \overline{RST} , and stays high until after the 1st start condition.
3. When selecting 3-wire or SPI modes, the user must ensure that a rising edge of SCLK does not occur within 300 ns before the rising edge of \overline{RST} .
4. If GPO1 and GPO2 are actively driven by the user, then minimum t_{SRST} is only 30 ns. If GPO1 or GPO2 is hi-Z, then minimum t_{SRST} is 100 μs , to provide time for on-chip 1 M Ω devices (active while \overline{RST} is low) to pull GPO1 high and GPO2 low.

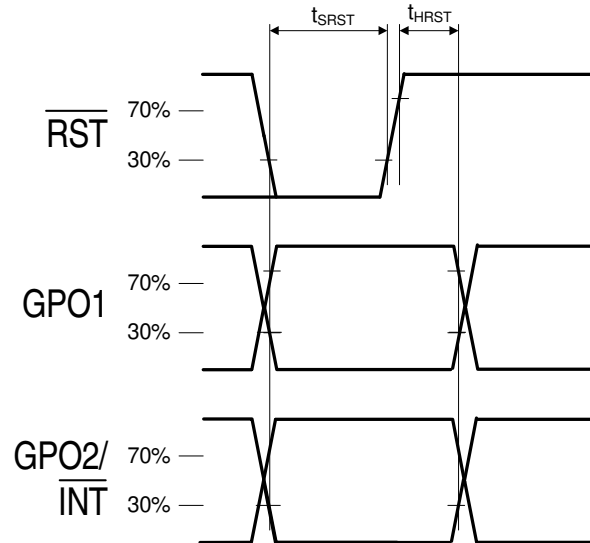

Figure 1. Reset Timing Parameters for Busmode Select

Table 5. 2-Wire Control Interface Characteristics^{1,2,3}(V_{DD} = 2.7 to 5.5 V, V_{IO} = 1.5 to 3.6 V, T_A = -20 to 85 °C)

Parameter	Symbol	Test Condition	Min	Typ	Max	Unit
SCLK Frequency	f _{SCL}		0	—	400	kHz
SCLK Low Time	t _{LOW}		1.3	—	—	μs
SCLK High Time	t _{HIGH}		0.6	—	—	μs
SCLK Input to SDIO↓ Setup (START)	t _{SU:STA}		0.6	—	—	μs
SCLK Input to SDIO↓ Hold (START)	t _{HD:STA}		0.6	—	—	μs
SDIO Input to SCLK↑ Setup	t _{SU:DAT}		100	—	—	ns
SDIO Input to SCLK↓ Hold ^{4,5}	t _{HD:DAT}		0	—	900	ns
SCLK input to SDIO↑ Setup (STOP)	t _{SU:STO}		0.6	—	—	μs
STOP to START Time	t _{BUF}		1.3	—	—	μs
SDIO Output Fall Time	t _{f:OUT}		$20 + 0.1 \frac{C_b}{1 \text{ pF}}$	—	250	ns
SDIO Input, SCLK Rise/Fall Time	t _{f:IN} t _{r:IN}		$20 + 0.1 \frac{C_b}{1 \text{ pF}}$	—	300	ns
SCLK, SDIO Capacitive Loading	C _b		—	—	50	pF
Input Filter Pulse Suppression	t _{SP}		—	—	50	ns

Notes:

1. When V_{IO} = 0 V, SCLK and SDIO are low-impedance. 2-wire control interface is I²C compatible.
2. When selecting 2-wire mode, the user must ensure that a 2-wire start condition (falling edge of SDIO while SCLK is high) does not occur within 300 ns before the rising edge of $\overline{\text{RST}}$.
3. When selecting 2-wire mode, the user must ensure that SCLK is high during the rising edge of $\overline{\text{RST}}$, and stays high until after the first start condition.
4. The Si4712/13 delays SDIO by a minimum of 300 ns from the V_{IH} threshold of SCLK to comply with the minimum t_{HD:DAT} specification.
5. The maximum t_{HD:DAT} has only to be met when f_{SCL} = 400 kHz. At frequencies below 400 kHz, t_{HD:DAT} may be violated as long as all other timing parameters are met.

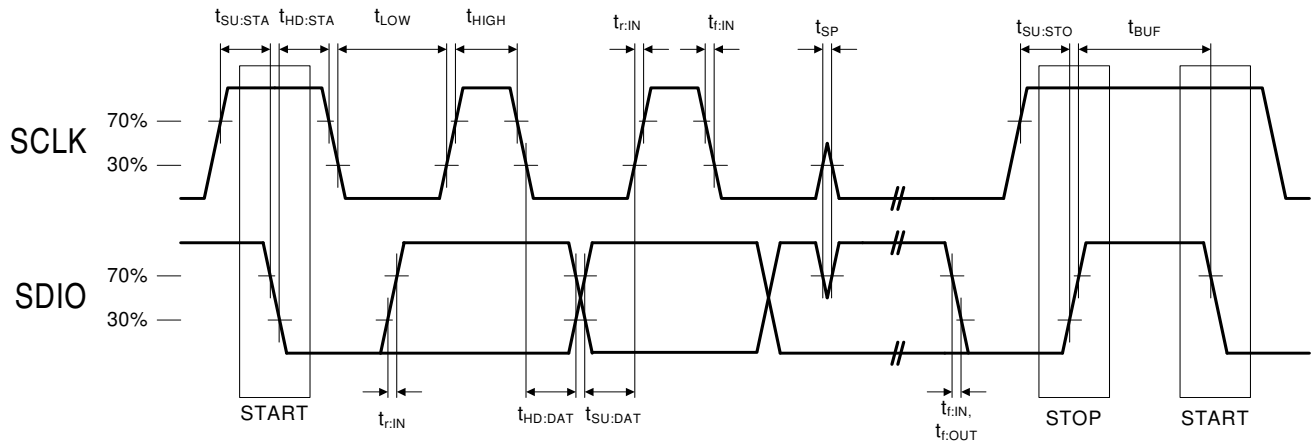

Figure 2. 2-Wire Control Interface Read and Write Timing Parameters

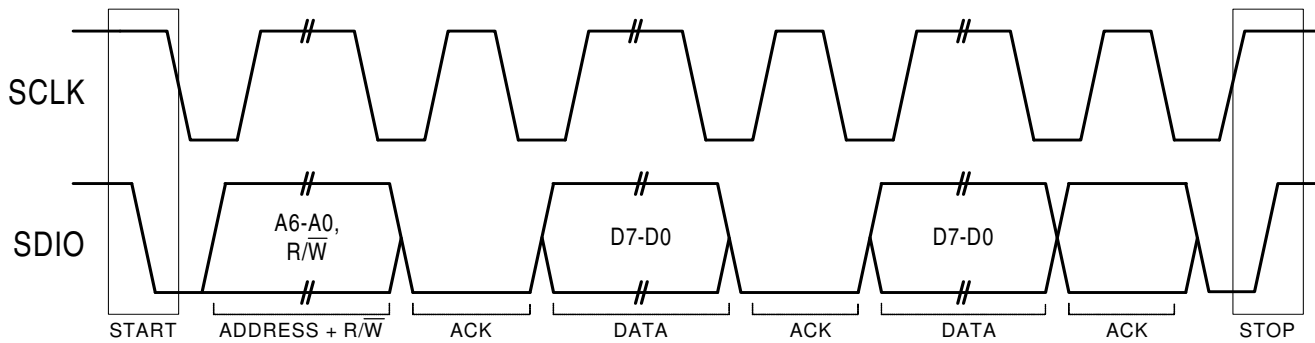

Figure 3. 2-Wire Control Interface Read and Write Timing Diagram

Table 6. 3-Wire Control Interface Characteristics

($V_{DD} = 2.7$ to 5.5 V, $V_{IO} = 1.5$ to 3.6 V, $T_A = -20$ to 85 °C)

Parameter	Symbol	Test Condition	Min	Typ	Max	Unit
SCLK Frequency	f_{CLK}		0	—	2.5	MHz
SCLK High Time	t_{HIGH}		25	—	—	ns
SCLK Low Time	t_{LOW}		25	—	—	ns
SDIO Input, \overline{SEN} to SCLK \uparrow Setup	t_S		20	—	—	ns
SDIO Input to SCLK \uparrow Hold	t_{HSDIO}		10	—	—	ns
\overline{SEN} Input to SCLK \downarrow Hold	t_{HSEN}		10	—	—	ns
SCLK \uparrow to SDIO Output Valid	t_{CDV}	Read	2	—	25	ns
SCLK \uparrow to SDIO Output High Z	t_{CDZ}	Read	2	—	25	ns
SCLK, \overline{SEN} , SDIO, Rise/Fall time	t_R t_F		—	—	10	ns

Note: When selecting 3-wire mode, the user must ensure that a rising edge of SCLK does not occur within 300 ns before the rising edge of RST.

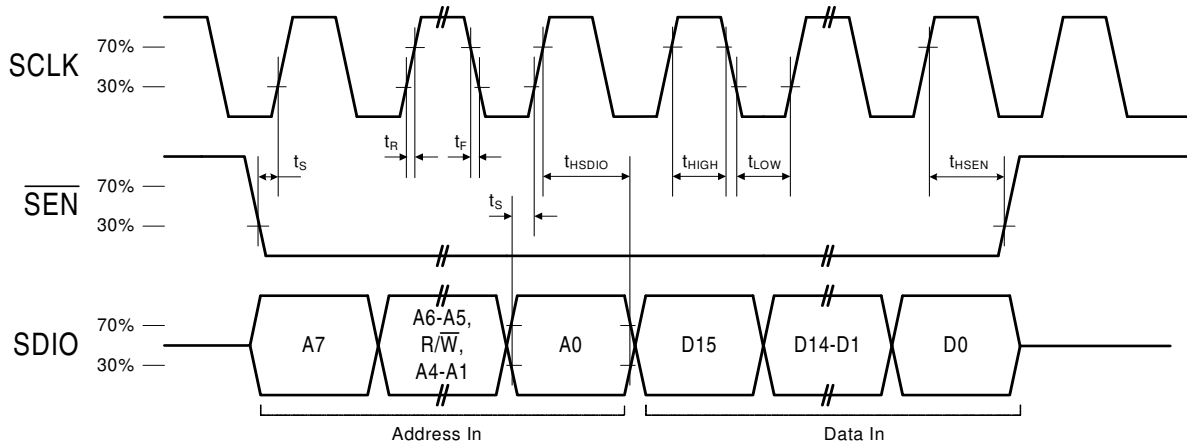

Figure 4. 3-Wire Control Interface Write Timing Parameters

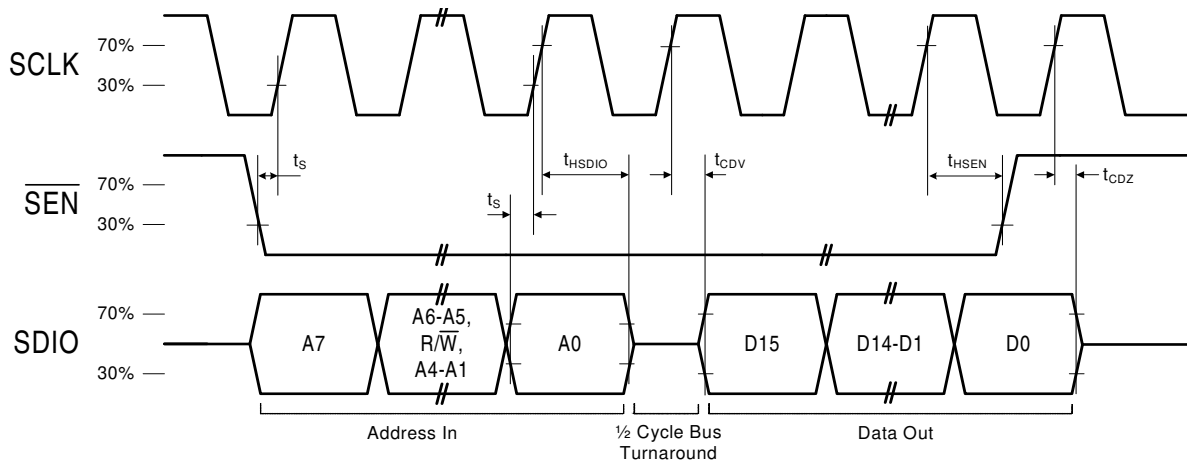

Figure 5. 3-Wire Control Interface Read Timing Parameters

Si4712/13-B30

Table 7. SPI Control Interface Characteristics

($V_{DD} = 2.7$ to 5.5 V, $V_{IO} = 1.5$ to 3.6 V, $T_A = -20$ to 85 °C)

Parameter	Symbol	Test Condition	Min	Typ	Max	Unit
SCLK Frequency	f_{CLK}		0	—	2.5	MHz
SCLK High Time	t_{HIGH}		25	—	—	ns
SCLK Low Time	t_{LOW}		25	—	—	ns
SDIO Input, \overline{SEN} to SCLK \uparrow Setup	t_S		15	—	—	ns
SDIO Input to SCLK \uparrow Hold	t_{HSDIO}		10	—	—	ns
\overline{SEN} Input to SCLK \downarrow Hold	t_{HSEN}		5	—	—	ns
SCLK \downarrow to SDIO Output Valid	t_{CDV}	Read	2	—	25	ns
SCLK \downarrow to SDIO Output High Z	t_{CDZ}	Read	2	—	25	ns
SCLK, \overline{SEN} , SDIO, Rise/Fall time	t_R, t_F		—	—	10	ns

Note: When selecting SPI mode, the user must ensure that a rising edge of SCLK does not occur within 300 ns before the rising edge of RST.

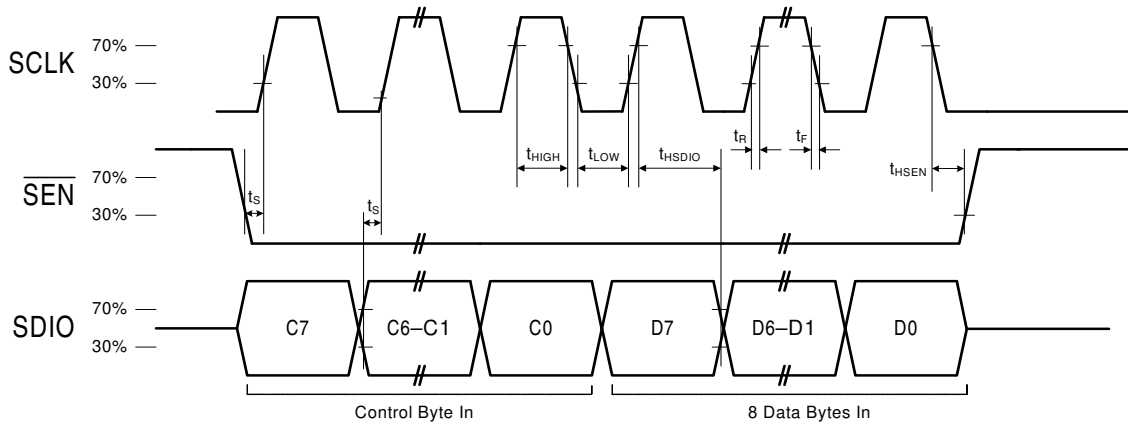

Figure 6. SPI Control Interface Write Timing Parameters

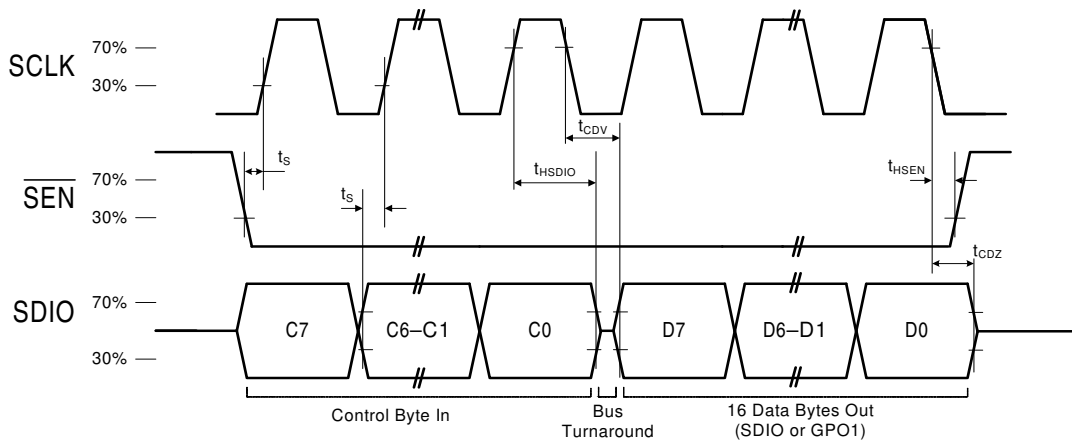

Figure 7. SPI Control Interface Read Timing Parameters

Table 8. Digital Audio Interface Characteristics $(V_{DD} = 2.7 \text{ to } 5.5 \text{ V}, V_{IO} = 1.5 \text{ to } 3.6 \text{ V}, T_A = -20 \text{ to } 85 \text{ }^\circ\text{C})$

Parameter	Symbol	Test Condition	Min	Typ	Max	Unit
DCLK pulse width high	t_{DCH}		10	—	—	ns
DCLK pulse width low	t_{DCL}		10	—	—	ns
DFS set-up time to DCLK rising edge	$t_{SU:DFS}$		5	—	—	ns
DFS hold time from DCLK rising edge	$t_{HD:DFS}$		5	—	—	ns
DIN set-up time from DCLK rising edge	$t_{SU:DIN}$		5	—	—	ns
DIN hold time from DCLK rising edge	$t_{HD:DIN}$		5	—	—	ns
DCLK, DFS, DIN, Rise/Fall time	t_R t_F		—	—	10	ns
DCLK Tx Frequency ^{1,2}			1.0	—	40.0	MHz

Notes:

1. Guaranteed by characterization.
2. The DCLK frequency may be set below the minimum specification if DIGITAL_INPUT_SAMPLE_RATE is first set to 0 (disable).

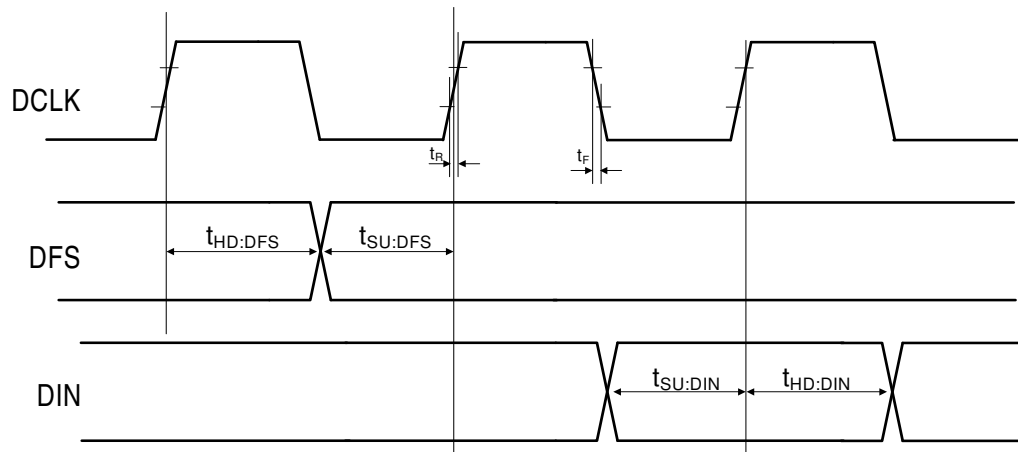
**Figure 8. Digital Audio Interface Timing Parameters, I²S Mode**

Si4712/13-B30

Table 9. FM Transmitter Characteristics¹

(Test conditions: $V_{RF} = 118 \text{ dB}\mu\text{V}$, stereo, $\Delta f = 68.25 \text{ kHz}$, $\Delta f_{\text{pilot}} = 6.75 \text{ kHz}$, $\text{REFCLK} = 32.768 \text{ kHz}$, $75 \mu\text{s}$ pre-emphasis, unless otherwise specified.)

Production test conditions: $V_{DD} = 3.3 \text{ V}$, $V_{IO} = 3.3 \text{ V}$, $T_A = 25 \text{ }^\circ\text{C}$, $F_{RF} = 98 \text{ MHz}$.

Characterization test conditions: $V_{DD} = 2.7 \text{ to } 5.5 \text{ V}$, $V_{IO} = 1.5 \text{ to } 3.6 \text{ V}$, $T_A = -20 \text{ to } 85 \text{ }^\circ\text{C}$, $F_{RF} = 76\text{--}108 \text{ MHz}$.

All minimum and maximum specifications are guaranteed and apply across the recommended operating conditions.

Typical values apply at $V_{DD} = 3.3 \text{ V}$ and $25 \text{ }^\circ\text{C}$ unless otherwise stated.

Parameters are tested in production unless otherwise specified.)

Parameter	Symbol	Test Condition	Min	Typ	Max	Unit
Transmit Frequency Range ²	f_{RF}		76	—	108	MHz
Transmit Frequency Accuracy and Stability ^{2,3}			-3.5	—	3.5	kHz
Transmit Voltage Accuracy ²		$V_{RF} = 103\text{--}117 \text{ dB}\mu\text{V}$	-2.5	—	2.5	dB
Transmit Voltage Accuracy		$V_{RF} = 102, 118 \text{ dB}\mu\text{V}$	-2.5	—	2.5	dB
Transmit Voltage Temperature Coefficient ²			-0.075	—	-0.025	dB/ $^\circ\text{C}$
Transmit Channel Edge Power		> $\pm 100 \text{ kHz}$, pre-emphasis off	—	—	-20	dBc
Transmit Adjacent Channel Power		> $\pm 200 \text{ kHz}$, pre-emphasis off	—	-30	-26	dBc
Transmit Alternate Channel Power		> $\pm 400 \text{ kHz}$, pre-emphasis off	—	-30	-26	dBc
Transmit Emissions		In-band (76–108 MHz)	—	—	-30	dBc
Output Capacitance Max ²	C_{TUNE}		—	53	—	pF
Output Capacitance Min ²	C_{TUNE}		—	5	—	pF
Pre-emphasis Time Constant ²		TX_PREMPHASIS = $75 \mu\text{s}$	70	75	80	μs
		TX_PREMPHASIS = $50 \mu\text{s}$	45	50	54	μs
Audio SNR Mono ²		$\Delta f = 22.5 \text{ kHz}$, Mono, limiter off	58	63	—	dB
Audio SNR Stereo		$\Delta f = 22.5 \text{ kHz}$, $\Delta f_{\text{pilot}} = 6.75 \text{ kHz}$, Stereo, limiter off	53	58	—	dB
Audio THD Mono		$\Delta f = 75 \text{ kHz}$, Mono, limiter off	—	0.1	0.5	%
Audio THD Stereo ²		$\Delta f = 22.5 \text{ kHz}$, $\Delta f_{\text{pilot}} = 6.75 \text{ kHz}$, Stereo, limiter off	—	0.1	0.5	%

Notes:

1. FM transmitter performance specifications are subject to adherence to Silicon Laboratories guidelines in “AN383: Universal Antenna Selection and Layout Guidelines.” Silicon Laboratories will evaluate schematics and layouts for qualified customers. Tested with test schematic (L = 120 nH, Q \geq 30) shown in Figure 9 on page 15.
2. Guaranteed by characterization.
3. No measurable $\Delta f_{RF}/\Delta V_{DD}$ at ΔV_{DD} of 500 mVpk-pk at 100 Hz to 10 kHz.

Table 9. FM Transmitter Characteristics¹ (Continued)

(Test conditions: $V_{RF} = 118 \text{ dB}\mu\text{V}$, stereo, $\Delta f = 68.25 \text{ kHz}$, $\Delta f_{\text{pilot}} = 6.75 \text{ kHz}$, $\text{REFCLK} = 32.768 \text{ kHz}$, $75 \mu\text{s}$ pre-emphasis, unless otherwise specified.)

Production test conditions: $V_{DD} = 3.3 \text{ V}$, $V_{IO} = 3.3 \text{ V}$, $T_A = 25 \text{ }^\circ\text{C}$, $F_{RF} = 98 \text{ MHz}$.

Characterization test conditions: $V_{DD} = 2.7 \text{ to } 5.5 \text{ V}$, $V_{IO} = 1.5 \text{ to } 3.6 \text{ V}$, $T_A = -20 \text{ to } 85 \text{ }^\circ\text{C}$, $F_{RF} = 76\text{--}108 \text{ MHz}$.

All minimum and maximum specifications are guaranteed and apply across the recommended operating conditions.

Typical values apply at $V_{DD} = 3.3 \text{ V}$ and $25 \text{ }^\circ\text{C}$ unless otherwise stated.

Parameters are tested in production unless otherwise specified.)

Parameter	Symbol	Test Condition	Min	Typ	Max	Unit
Audio Stereo Separation ²		left channel only	30	35	—	dB
Sub Carrier Rejection Ratio	SCR		40	50	—	dB
Powerup Settling Time ²			—	—	110	ms
Input Signal Level ²	V_{AI}		—	—	0.636	V_{PK}
Frequency Flatness ²		Mono, $\pm 1.5 \text{ dB}$, $\Delta f = 75 \text{ kHz}$, 0, 50, $75 \mu\text{s}$ pre-emphasis, limiter off	30	—	15 k	Hz
High Pass Corner Frequency ²		Mono, -3 dB , $\Delta f = 75 \text{ kHz}$, 0, 50, $75 \mu\text{s}$ pre-emphasis, limiter off	5	—	30	Hz
Low Pass Corner Frequency ²		Mono, -3 dB , $\Delta f = 75 \text{ kHz}$, 0, 50, $75 \mu\text{s}$ pre-emphasis, limiter off	15 k	—	16 k	Hz
Audio Imbalance		Mono	-1	—	1	dB
Pilot Modulation Rate Accuracy ²		$\Delta f = 68.25 \text{ kHz}$, $\Delta f_{\text{pilot}} = 6.75 \text{ kHz}$, Stereo	-10	—	10	%
Audio Modulation Rate Accuracy ²		$\Delta f = 68.25 \text{ kHz}$, $\Delta f_{\text{pilot}} = 6.75 \text{ kHz}$, Stereo	-10	—	10	%
Input Resistance ²		LIATTEN[1:0] = 11	50	60	—	$k\Omega$
Input Capacitance ²			—	10	—	pF
Received Noise Level Accuracy (Si4712/13 Only) ²		60 $\text{dB}\mu\text{V}$ input, $T_A = 25 \text{ }^\circ\text{C}$	—	54	—	dBuV

Notes:

1. FM transmitter performance specifications are subject to adherence to Silicon Laboratories guidelines in "AN383: Universal Antenna Selection and Layout Guidelines." Silicon Laboratories will evaluate schematics and layouts for qualified customers. Tested with test schematic (L = 120 nH, Q \geq 30) shown in Figure 9 on page 15.
2. Guaranteed by characterization.
3. No measurable $\Delta f_{RF}/\Delta V_{DD}$ at ΔV_{DD} of 500 mVpk-pk at 100 Hz to 10 kHz.

Si4712/13-B30

Table 10. FM Receive Power Scan Characteristics^{1,2}

($V_{DD} = 2.7$ to 5.5 V, $V_{IO} = 1.5$ to 3.6 V, $T_A = -20$ to 85 °C, $F_{RF} = 76$ – 108 MHz)

Parameter	Symbol	Test Condition	Min	Typ	Max	Unit
Tune and Signal Strength Measurement Time per Channel			—	—	80	ms

Notes:

1. Settling time for ac coupling capacitors on the audio input pins after Receive to Transmit transition can take a few hundred milliseconds. The actual settling time depends on the values of the ac-coupling capacitors. Using digital audio input mode avoids this settling time.
2. Guaranteed by characterization.

Table 11. Reference Clock Characteristics

($V_{DD} = 2.7$ to 5.5 V, $V_{IO} = 1.5$ to 3.6 V, $T_A = -20$ to 85 °C, $F_{RF} = 76$ – 108 MHz)

Supported Parameter	Symbol	Test Condition	Min	Typ	Max	Unit
RCLK Frequency Range ^{1,2}			31.130	32.768	40,000	kHz
Frequency Tolerance ¹			-50	—	50	ppm

Notes:

1. Guaranteed by characterization.
2. The RCLK frequency divided by an integer number (the prescaler value) must fall in the range of 31,130 to 34,406 Hz. Therefore, the range of RCLK frequencies is not continuous below frequencies of 311.3 kHz.

2. Test Circuit

2.1. Test Circuit Schematic

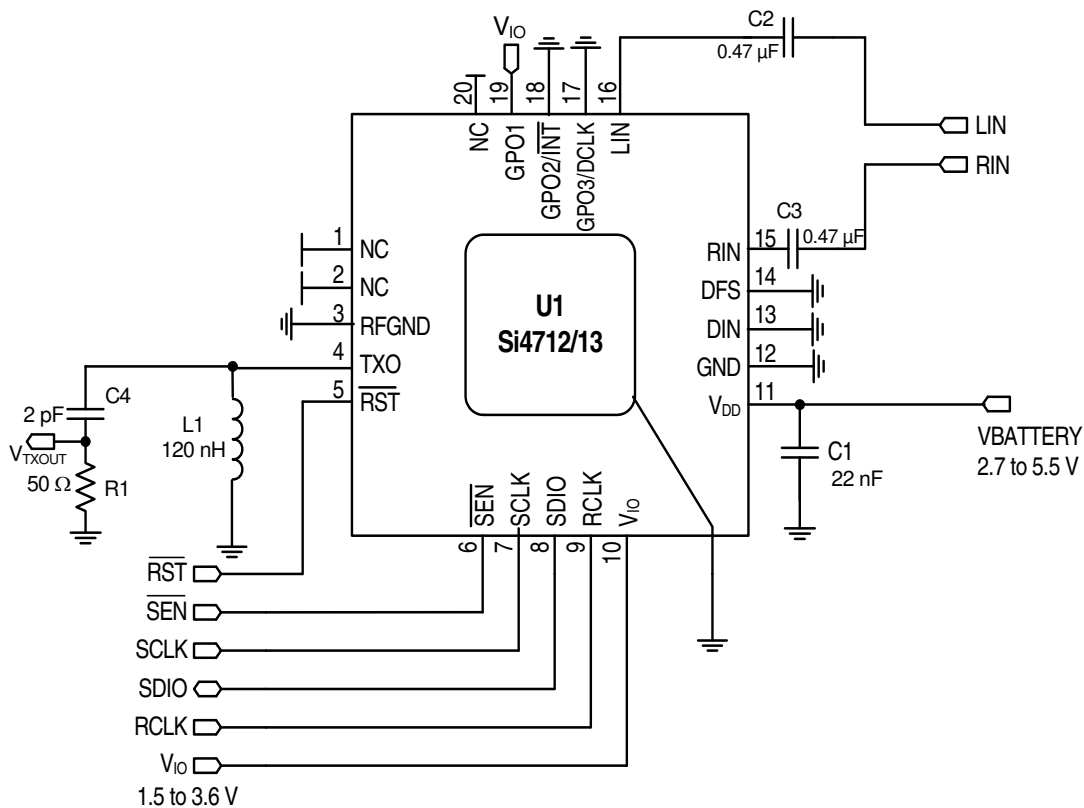

Notes:

1. Si4712/13 is shown configured in I²C compatible bus mode.
2. GPO2/INT can be configured for interrupts with the powerup command.
3. To ensure proper operation and FM transmitter performance, follow the guidelines in "AN383: 3 mm x 3 mm QFN Universal Layout Guide."
Silicon Laboratories will evaluate schematics and layouts for qualified customers.
4. LIN, RIN line inputs must be ac-coupled.

Figure 9. Test Circuit Schematic

2.2. Test Circuit Bill of Materials

Table 12. Si4712/13 Test Circuit Bill of Materials

Component(s)	Value/Description	Supplier(s)
C1	Supply bypass capacitor, 22 nF, 20%, Z5U/X7R	Murata
C2, C3	AC Coupling Capacitor, 0.47 μF	Murata
C4	2 pF, ±.05 pF, 06035JZR0AB	AVX
L1	120 nH inductor, Qmin = 30	Murata
R1	49.9 Ω, 5%	Murata
U1	Si4712/13 FM Radio Transmitter	Silicon Laboratories

Si4712/13-B30

3. Typical Application Schematics

3.1. Analog Audio Inputs

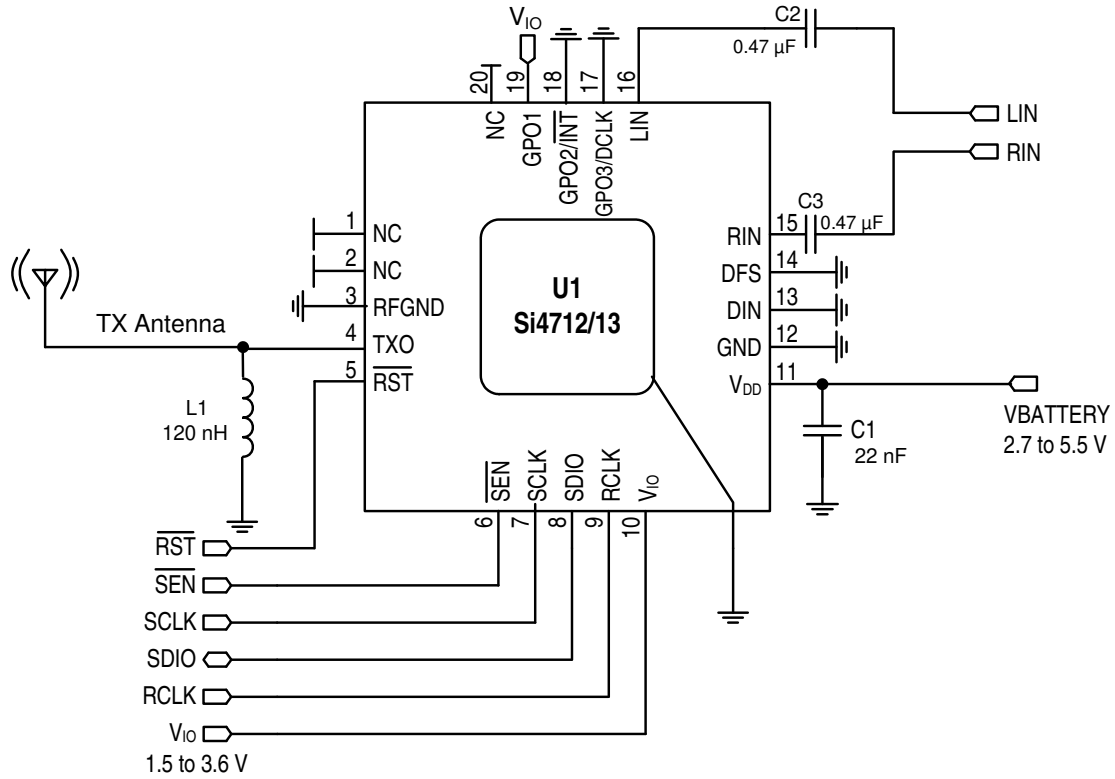

Notes:

1. Si4712/13 is shown configured in I²C compatible bus mode.
2. GPO2/INT can be configured for interrupts with the powerup command.
3. To ensure proper operation and FM transmitter performance, follow the guidelines in "AN383: 3 mm x 3 mm QFN Universal Layout Guide."
Silicon Laboratories will evaluate schematics and layouts for qualified customers.
4. LIN, RIN line inputs must be ac-coupled.

Figure 10. Analog Audio Inputs (LIN, RIN)

3.2. Digital Audio Inputs

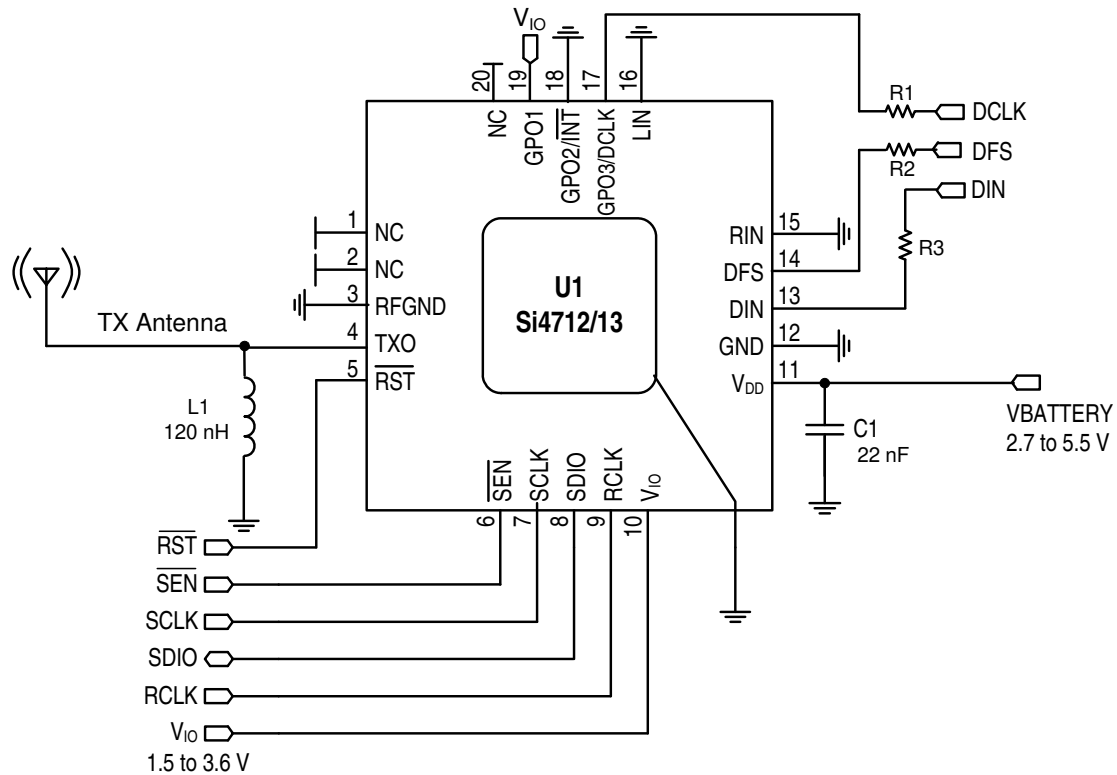

Notes:

1. Si4712/13 is shown configured in I²C compatible bus mode.
2. GPO2/INT can be configured for interrupts with the powerup command.
3. To ensure proper operation and FM transmitter performance, follow the guidelines in "AN383: Si47xx 3 mm x 3 mm QFN Universal Layout Guide."
Silicon Laboratories will evaluate schematics and layouts for qualified customers.

Figure 11. Digital Audio Inputs (DIN, DFS, DCLK)

3.3. Typical Application Schematic Bill of Materials

Table 13. Si4712/13 Bill of Materials

Component(s)	Value/Description	Supplier(s)
C1	Supply bypass capacitor, 22 nF, 20%, Z5U/X7R	Murata
C2, C3	AC Coupling Capacitor, 0.47 μF	Murata
L1	120 nH inductor, Qmin = 30	Murata
R1, R2	2 kΩ Resistor	Any
R3	600 Ω Resistor	Any
U1	Si4712/13 FM Radio Transmitter	Silicon Laboratories

4. Universal AM/FM RX/FM TX Application Schematic

Figure 12 shows an application schematic that supports the Si47xx family of 3 mm x 3 mm QFN products, including the Si4702/3/4/5 FM receivers, Si471x FM transmitters, Si472x FM transceivers, and Si473x AM/FM receivers.

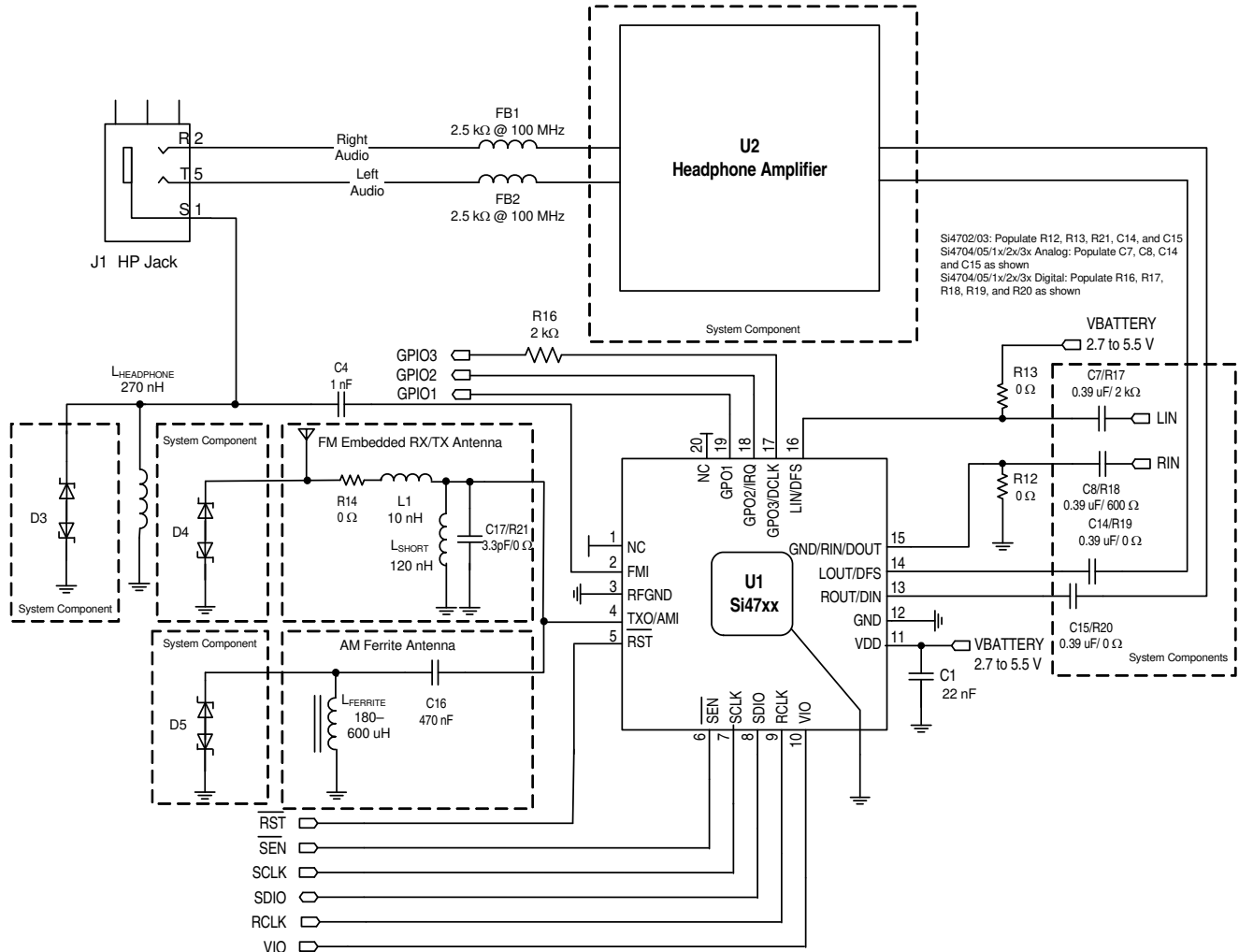

Figure 12. Universal AM/FM RX/FM TX Application Schematic

Following the schematic and layout recommendations detailed in “AN383: Universal Antenna Selection and Layout Guidelines” will result in optimal performance with the minimal application schematic shown in Figure 12. “Universal AM/FM RX/FM TX Application Schematic”. System components are those that are likely to be present for any tuner or transmitter design.

4.1. Universal AM/FM RX/FM TX Bill of Materials

The bill of materials for the expanded application schematic shown in Figure 12 is provided in Table 14. Refer to the individual device layout guides and antenna interface guides for a discussion of the purpose of each component.

Table 14. Universal AM/FM RX/FM TX Bill of Materials

Designator	Description	Note
C1	Supply bypass capacitor, 22 nF, 10%, Z5U/X7R, 0402	
U1	Silicon Laboratories Si47xx, 3 mm x 3 mm, 20 pin, QFN	
R12, R13, R19, R20, R21	0 Ω jumper, 0402	R12, R13, and R21 for Si4702/03 Only
C16	AM antenna ac coupling capacitor, 470 nF, 20%, Z5U/X7R	AM Ferrite Antenna
LFERRITE	AM Ferrite loop stick, 180–600 μ H	AM Ferrite Antenna
FB1,FB2	Ferrite bead, 2.5 k Ω @ 100 MHz, 0603, Murata BLM18BD252SN1D	Headphone Antenna
LHEADPHONE	Headphone antenna matching inductor, 270 nH, 0603, Q>15, Murata LQW18ANR27J00D	Headphone Antenna
LSHORT	Embedded antenna matching inductor, 120 nH, 0603, Q>30, Murata LQW18ANR12J00D	Embedded Antenna
R14	Embedded antenna jumper, 2.2 Ω , 0402	Optional
C2	Supply bypass capacitor, 22 nF, 10%, Z5U/X7R, 0402	Optional
C3	Supply bypass capacitor, 100 nF, 10%, Z5U/X7R, 0402	Optional
C5, C6	Headphone amp output shunt capacitor, 100 pF, 10%, Z5U/X7R, 0402	Optional
R7-R11	Current limiting resistor, 20 Ω –2 k Ω , 0402	Optional
C12, C13	Crystal load capacitor, 22 pF, 5%, COG	Optional
X1	Crystal, Epson FC-135	Optional
C7, C8	Si47xx input ac coupling capacitor, 0.39 μ F, X7R/X5R, 0402	System Component
D1-D5	ESD Diode, SOT23-3, California Micro Devices CM1214-01ST	System Component
C11	Supply bypass capacitor, 100 nF, 10%, Z5U/X7R, 0402	Headphone Amplifier
C4	Headphone antenna ac coupling capacitor, 1 nF, 10%, Z5U/X7R, 0402	Headphone Antenna
C9, C10	Headphone amp output ac coupling capacitor, 125 μ F, X7R, 0805	Headphone Amplifier
C14, C15	Headphone amp input ac coupling capacitor, 0.39 μ F, X7R/X5R, 0402	Headphone Amplifier
R1,R2,R3,R4	Headphone amp feedback/gain resistor, 20 k Ω , 0402	Headphone Amplifier
R5, R6	Headphone amp bleed resistor, 100 k Ω , 0402	Headphone Amplifier
U2	Headphone amplifier, National Semiconductor, LM4910MA	Headphone Amplifier
R16, R17	Current limiting resistor, 2 k Ω , 0402	System Component
R18	Current limiting resistor, 600 Ω , 0402	System Component
L1	VCO filter inductor, 10 nH, 0603, Q>30, Murata, LQW18ANR01J00D	Optional
C17	VCO filter capacitor, 3.3 pF, 0402, COG, Venkel, C0402COG2503R3JN	Optional

5. Functional Description

5.1. Overview

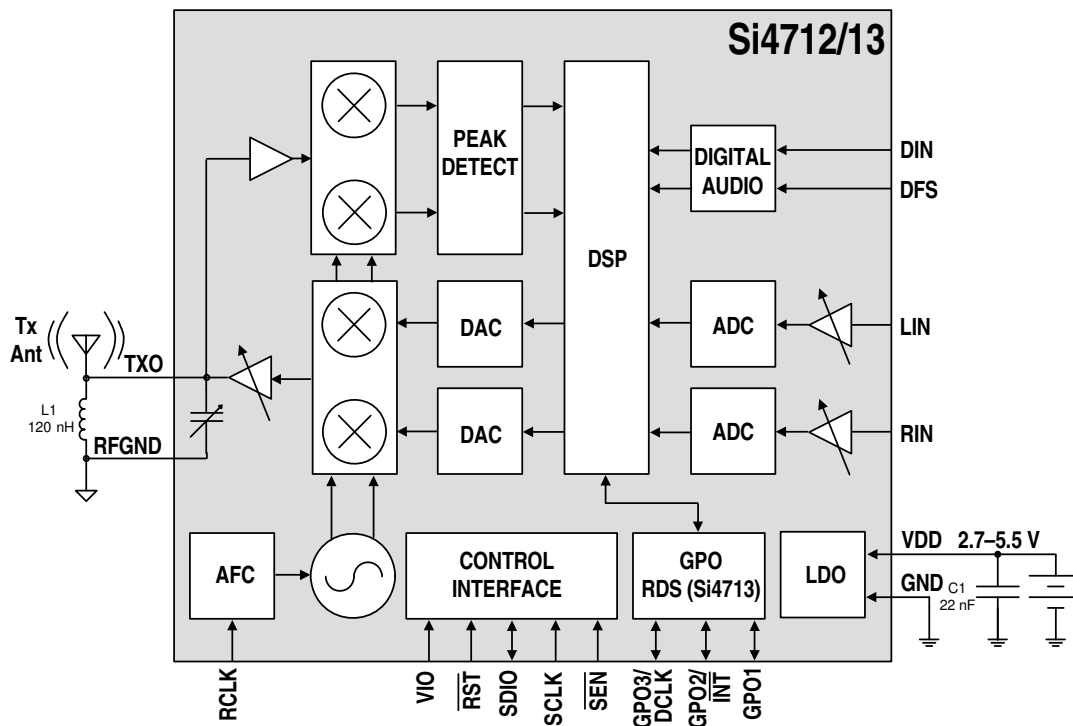

Figure 13. Functional Block Diagram

The Si4712/13 is the first 100% CMOS FM radio transmitter with integrated receive functionality to measure received signal strength. The device leverages Silicon Labs' highly successful and proven Si4700/01 FM receiver patent family and offers unmatched integration and performance, allowing FM transmit to be added to any portable device with a single chip. The Si4712/13 offers industry-leading size, performance, low power consumption, flexibility, and ease of use.

The Si4712/13's digital integration reduces the required external components of traditional offerings, resulting in a solution requiring only an external inductor and bypass capacitor, and PCB space of approximately 15 mm². This increases the device reliability and simplifies the design and manufacturing for companies adopting this technology.

The Si4712/13's integrated receive power scan function shares the same antenna as the transmitter allowing for a compact printed circuit board design. The device operates in half duplex mode, meaning the transmitter and receiver do not operate at the same time.

The Si4712/13 performs FM modulation in the digital domain to achieve high fidelity, optimal performance versus power consumption, and flexibility of design. The

onboard DSP provides modulation adjustment and audio dynamic range control for optimum sound quality.

The Si4713 supports the European Radio Data System (RDS) and the US Radio Broadcast Data System (RBDS) including all the symbol encoding, block synchronization, and error correction functions. Using this feature, the Si4713 enables data such as artist name and song title to be transmitted to an RDS/RBDS receiver.

The transmit output (TXO) connects directly to the transmit antenna with only one external inductor to provide harmonic filtering. The output is programmable over a 10 dB voltage range in 1 dB steps. The TXO output pin can also be configured for loop antenna support. Users are responsible for complying with local regulations on RF transmission (FCC, ETSI, ARIB, etc.).

The digital audio interface operates in slave mode and supports a variety of MSB-first audio data formats including I²S and left-justified modes. The interface has three pins: digital data input (DIN), digital frame synchronization input (DFS), and a digital bit synchronization input clock (DCLK). The Si4712/13 supports a number of industry-standard sampling rates

including 32, 40, 44.1, and 48 kHz. The digital audio interface enables low-power operation by eliminating the need for redundant DACs and ADCs on the audio baseband processor.

The Si4712/13 includes a low-noise stereo line input (LIN/RIN) with programmable attenuation. To ensure optimal audio performance, the Si4712/13 has a transmit line input property that allows the user to specify the peak amplitude of the analog input required to reach maximum deviation level. The deviation levels of the audio, pilot, and RDS/RBDS signals can be independently programmed to customize FM transmitter designs. The Si4712/13 has a programmable low audio level and high audio level indicators that allows the user to selectively enable and disable the carrier based on the presence of audio content. In addition, the device provides an overmodulation indicator to allow the user to dynamically set the maximum deviation level. The Si4712/13 has a programmable audio dynamic range control that can be used to reduce the dynamic range of the audio input signal and increase the volume at the receiver. These features can dramatically improve the end user's listening experience.

The Si4712/13 is reset by applying a logic low on the RST pin. This causes all register values to be reset to their default values. The digital input/output interface supply (V_{IO}) provides voltage to the RST, SEN, SDIO, RCLK, DIN, DFS, and DCLK pins and can be connected to the audio baseband processor's supply voltage to save power and remove the need for voltage level translators. RCLK is not required for register operation.

The Si4712/13 reference clock is programmable, supporting many RCLK inputs as shown in Table 9.

The Si4712/13 are part of a family of broadcast audio solutions offered in standard, 3 x 3 mm 20-pin QFN packages. All solutions are layout compatible, allowing a single PCB to accommodate various feature offerings.

The Si4712/13 includes line inputs to the on-chip analog-to-digital converters (ADC), a programmable reference clock input, and a configurable digital audio interface. The chip supports I²C-compliant 2-wire, 8-bit SPI, and a 3-wire control interface.

5.2. FM Transmitter

The transmitter (TX) integrates a stereo audio ADC to convert analog audio signals to high fidelity digital signals. Alternatively, digital audio signals can be applied to the Si4712/13 directly to reduce power consumption by eliminating the need to convert audio baseband signals to analog and back again to digital. Digital signal processing is used to perform the stereo MPX encoding and FM modulation to a low digital IF. Transmit baseband filters suppress out-of-channel noise and images from the digital low-IF signal. A quadrature single-sideband mixer up-converts the digital IF signal to RF, and internal RF filters suppress noise and harmonics to support the harmonic emission requirements of cellular phones, GPS, WLAN, and other wireless standards.

The TXO output has over 10 dB of output level control, programmable in approximately 1 dB steps. This large output range enables a variety of antennas to be used for transmit, such as a monopole stub antenna or a loop antenna. The 1 dB step size provides fine adjustment of the output voltage.

The TXO output requires only one external 120 nH inductor. The inductor is used to resonate the antenna and is automatically calibrated within the integrated circuit to provide the optimum output level and frequency response for supported transmit frequencies. Users are responsible for adjusting their system's radiated power levels to comply with local regulations on RF transmission (FCC, ETSI, ARIB, etc.).

5.3. Receive Power Scan

The Si4712/13 is the industry's first FM transmitter with integrated receive functionality to measure received signal strength. This has been designed to specifically handle various antenna lengths including integrated PCB antennas, wire antennas, and loop antennas, allowing it to share the same antenna as the transmitter. The receive function reuses the on-chip varactor from the transmitter to optimize the receive signal power applied to the front-end amplifier. Auto-calibration of the varactor occurs with each tune command for consistent performance across the FM band.

5.3.1. Stereo Encoder

Figure 14 shows an example modulation level breakdown for the various components of a typical MPX signal.

The total modulation level for the MPX signal shown in Figure 14, assuming no correlation, is equal to the arithmetic sum of each of the subchannel levels resulting in 102.67 percent modulation or a peak frequency deviation of 77.0025 kHz (an instantaneous frequency deviation of 75 kHz corresponds to 100 percent modulation). Frequency deviation is related to the amplitude of the MPX signal by a gain constant, K_{VCO} , as given by the following equation:

$$\Delta f = K_{VCO} A_m$$

where Δf is the frequency deviation; K_{VCO} is the voltage-to-frequency gain constant, and A_m is the amplitude of the MPX message signal. For a fixed K_{VCO} , the amplitude of all the subchannel signals within the MPX message signal must be scaled to give the appropriate total frequency deviation.

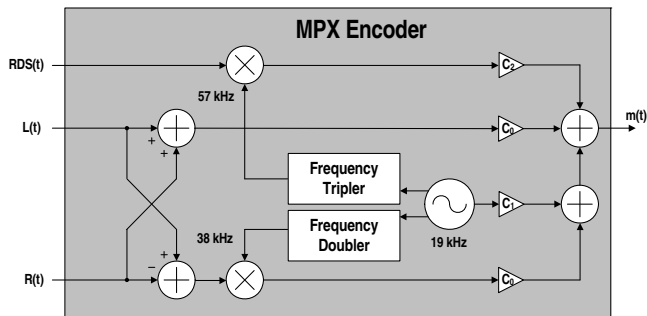

Figure 14. MPX Encoder

Figure 14 shows a conceptual block diagram of an MPX encoder used to generate the MPX signal. $L(t)$ and $R(t)$ denote the time domain waveforms from the left and right audio channels, and $RDS(t)$ denotes the time domain waveform of the RDS/RBDS signal.

The MPX message signal can be expressed as follows:

$$m(t) = C_0[L(t) + R(t)] + C_1 \cos(2\pi 19 \text{ kHz}) + C_0[L(t) - R(t)] \cos(2\pi 38 \text{ kHz}) + C_2 RDS(t) \cos(2\pi 57 \text{ kHz})$$

where C_0 , C_1 , and C_2 are gains used to scale the amplitudes of the audio signals ($L(t) \pm R(t)$), the 19 kHz pilot tone, and the RDS subcarrier respectively, to generate the appropriate modulation level. To achieve the modulation levels of Figure 14 with $K_{VCO} = 75 \text{ kHz/V}$, C_0 would be set to 0.45; C_1 would be set to 0.1, and C_2 would be set to 0.0267 giving a peak audio frequency deviation of $0.9 \times 75 \text{ kHz} = 67.5 \text{ kHz}$, a peak pilot frequency deviation of $0.1 \times 75 \text{ kHz} = 7.5 \text{ kHz}$, and a peak RDS frequency deviation of $0.0267 \times 75 \text{ kHz} = 2.0025 \text{ kHz}$ for a total peak frequency deviation of 77.0025 kHz.

In the Si4712/13, the peak audio, pilot, and RDS frequency deviations can be programmed directly with the Transmit Audio, Pilot, and RDS Deviation commands with an accuracy of 10 Hz. For the example in Figure 14, the Transmit Audio Deviation is programmed with the value 6750, the Transmit Pilot Deviation with 750, and the Transmit RDS Deviation with 200, generating peak audio frequency deviations of 67.5 kHz, peak pilot deviations of 7.5 kHz, and peak RDS deviations of 2.0 kHz for a total peak frequency deviation of 77 kHz. The total peak transmit frequency deviation of the Si4712/13 can range from 0 to 100 kHz and is equal to the arithmetic sum of the Transmit Audio, Pilot, and RDS deviations. Users must comply with local regulations on radio frequency transmissions.

Each of the individual deviations (transmit audio, pilot, and RDS) can be independently programmed; however, the total peak frequency deviation cannot exceed 100 kHz.

The Si4712/13 provides an overmodulation indicator to allow the user to dynamically set the maximum deviation level. If the instantaneous frequency exceeds the deviation level specified by the TX_AUDIO_DEVIATION property, the SQINT interrupt bit (and optional interrupt) will be set.

5.4. Digital Audio Interface

The digital audio interface operates in slave mode and supports 3 different audio data formats:

1. I²S
2. Left-Justified
3. DSP Mode

5.4.1. Audio Data Formats

In I²S mode, the MSB is captured on the second rising edge of DCLK following each DFS transition. The remaining bits of the word are sent in order, down to the LSB. The Left Channel is transferred first when the DFS is low, and the Right Channel is transferred when the DFS is high.

In Left-Justified mode, the MSB is captured on the first rising edge of DCLK following each DFS transition. The remaining bits of the word are sent in order, down to the LSB. The Left Channel is transferred first when the DFS is high, and the Right Channel is transferred when the DFS is low.

In DSP mode, the DFS becomes a pulse with a width of 1 DCLK period. The Left Channel is transferred first, followed right away by the Right Channel. There are two options in transferring the digital audio data in DSP mode: the MSB of the left channel can be transferred on the first rising edge of DCLK following the DFS pulse or on the second rising edge.

In all audio formats, depending on the word size, DCLK frequency and sample rates, there may be unused DCLK cycles after the LSB of each word before the next DFS transition and MSB of the next word.

The number of audio bits can be configured for 8, 16, 20, or 24 bits.

5.4.2. Audio Sample Rates

The device supports a number of industry-standard sampling rates including 32, 40, 44.1, and 48 kHz. The digital audio interface enables low-power operation by eliminating the need for redundant DACs and ADCs on the audio baseband processor. The sampling rate is selected using the DIGITAL_INPUT_SAMPLE_RATE property.

The device supports DCLK frequencies above 1 MHz. After powerup the DIGITAL_INPUT_SAMPLE_RATE property defaults to 0 (disabled). After DCLK is supplied, the DIGITAL_INPUT_SAMPLE_RATE property should be set to the desired audio sample rate such as 32, 40, 44.1, or 48 kHz. The DIGITAL_INPUT_SAMPLE_RATE property must be set to 0 before DCLK is removed or the DCLK frequency drops below 1 MHz. A device reset is required if this requirement is not followed.

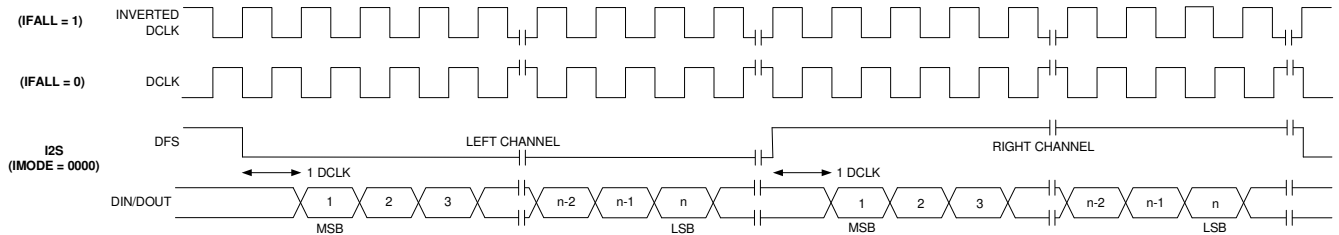

Figure 15. I²S Digital Audio Format

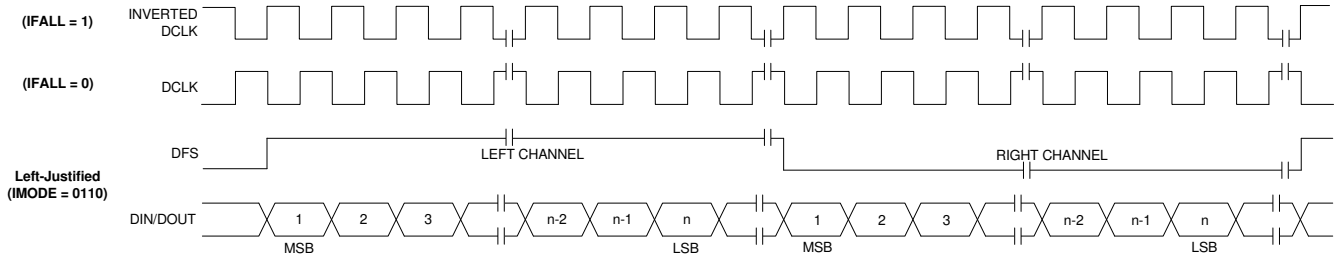

Figure 16. Left-Justified Digital Audio Format

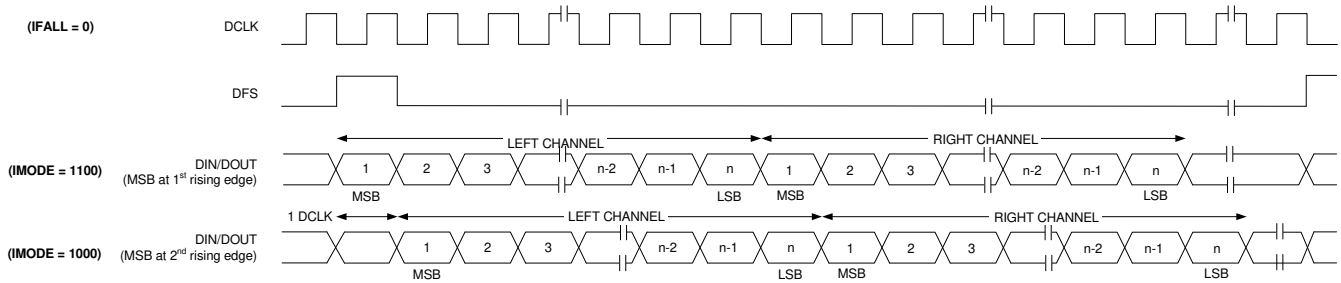

Figure 17. DSP Digital Audio Format

5.5. Line Input

The Si4712/13 provides left and right channel line inputs (LIN and RIN). The inputs are high-impedance and low-capacitance, suited to receiving line level signals from external audio baseband processors. Both line inputs are low-noise inputs with programmable attenuation. Passive and active anti-aliasing filters are incorporated to prevent high frequencies from aliasing into the audio band and degrading performance.

To ensure optimal audio performance, the Si4712/13 has a TX_LINE_INPUT_LEVEL property that allows the user to specify the peak amplitude of the analog input (LILEVEL[9:0]) required to reach the maximum deviation level programmed in the audio deviation property, TX_AUDIO_DEVIATION. A corresponding line input attenuation code, LIATTEN[1:0], is also selected by the expected peak amplitude level. Table 15 shows the line attenuation codes.

Table 15. Line Attenuation Codes

LIATTEN[1:0]	Peak Input Voltage [mV]	RIN/LIN Input Resistance [k Ω]
00	190	396
01	301	100
10	416	74
11	636	60

The line attenuation code is chosen by picking the lowest Peak Input Voltage in Table 15 that is just above the expected peak input voltage coming from the audio baseband processor. For example, if the expected peak input voltage from the audio baseband processor is 400 mV, the user chooses LIATTEN[1:0] = 10 since the Peak Input Voltage of 416 mV associated with LIATTEN[1:0] = 10 is just greater than the expected peak input voltage of 400 mV. The user also enters 400 mV into the LILEVEL[9:0] to associate this input level to the maximum frequency deviation level programmed into the audio deviation property. Note that selecting a particular value of LIATTEN[1:0] changes the input resistance of the LIN and RIN pins. This feature is used for cases where the expected peak input level exceeds the maximum input level of the LIN and RIN pins.

The maximum analog input level is 636 mVpK. If the analog input level from the audio baseband processor exceeds this voltage, series resistors must be inserted in front of the LIN and RIN pins to attenuate the voltage such that it is within the allowable operating range. For example, if the audio baseband's expected peak amplitude is 900 mV and the V_{IO} supply voltage is 1.8 V, the designer can use 30 k Ω series resistors in front of the LIN and RIN pins and select LIATTEN[1:0] = 11. The resulting expected peak input voltage at the LIN/RIN pins is 600 mV, since this is just a voltage divider between the LIN/RIN input resistance (see Table 15, 60 k Ω for this example) and the external resistor. Note that the Peak Input Voltage corresponding to the chosen LIATTEN[1:0] code still needs to satisfy the condition of being just greater than the attenuated voltage. In this example, a line attenuation code of LIATTEN[1:0] = 11 has a Peak Input Voltage of 636 mV, which is just greater than the expected peak attenuated voltage of 600 mV. Also, the expected peak attenuated voltage is entered into the LILEVEL[9:0] parameter. Again, in this example, 600 mV is entered into LILEVEL[9:0]. This example shows one possible solution, but many other solutions exist. The optimal solution is to apply the largest possible voltage to the LIN and RIN pins for signal-to-noise considerations; however, practical resistor values may limit the choices.

Note that the TX_LINE_INPUT_LEVEL parameter will affect the high-pass filter characteristics of the ac-coupling capacitors and the resistance of the audio inputs.

The Si4712/13 has a programmable low audio level and high audio level indicators that allows the user to selectively enable and disable the carrier based on the presence of audio content. The TX_ASQ_LEVEL_LOW and TX_ASQ_LEVEL_HIGH parameters set the low level and high level thresholds in dBFS, respectively. The time required for the audio level to be below the low threshold is set with the TX_ASQ_DURATION_LOW parameter, and similarly, the time required for the audio level to be above the high threshold is set with the TX_ASQ_DURATION_HIGH parameter.