



Chipsmall Limited consists of a professional team with an average of over 10 year of expertise in the distribution of electronic components. Based in Hongkong, we have already established firm and mutual-benefit business relationships with customers from,Europe,America and south Asia,supplying obsolete and hard-to-find components to meet their specific needs.

With the principle of “Quality Parts,Customers Priority,Honest Operation,and Considerate Service”,our business mainly focus on the distribution of electronic components. Line cards we deal with include Microchip,ALPS,ROHM,Xilinx,Pulse,ON,Everlight and Freescale. Main products comprise IC,Modules,Potentiometer,IC Socket,Relay,Connector.Our parts cover such applications as commercial,industrial, and automotives areas.

We are looking forward to setting up business relationship with you and hope to provide you with the best service and solution. Let us make a better world for our industry!



Contact us

Tel: +86-755-8981 8866 Fax: +86-755-8427 6832

Email & Skype: info@chipsmall.com Web: www.chipsmall.com

Address: A1208, Overseas Decoration Building, #122 Zhenhua RD., Futian, Shenzhen, China



BROADCAST MECHANICAL TUNING AM/FM/SW RADIO RECEIVER

Features

- Worldwide FM band support (64–109 MHz)
- Worldwide AM band support (504–1750 kHz)
- SW band support (Si4824 only) (5.6–22 MHz)
- No manual alignment necessary
- Mono audio output
- Selectable support AM/FM/SW regional bands
- Automatic frequency control (AFC)
- Integrated LDO regulator
- 2.0 to 3.6 V supply voltage
- Wide range of ferrite loop sticks and air loop antennas supported
- 24-pin SSOP
- RoHS-compliant
- Direct volume control
- Not EN55020 compliant*

***Note:** For consumer applications that require EN 55020 compliance, use Si4831/35-B.

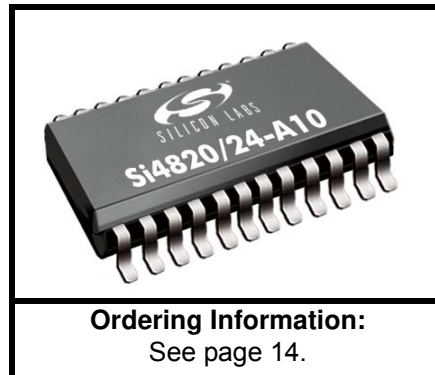

Applications

- Table and portable radios
- Mini/micro systems
- CD/DVD players
- Boom boxes
- Modules
- Clock radios
- Mini HiFi
- Entertainment systems

Description

The Si4820/24-A10 is the entry level mechanical-tuned digital CMOS AM/FM/SW radio receiver IC that integrates the complete receiver function from antenna input to audio output. The Si4820/24-A10 extends Silicon Laboratories multi-band tuner family, and further increases the ease and attractiveness of design radio reception to audio devices through small size and board area, minimum component count, and superior, proven performance. The Si4820/24-A10 is drop-in replaceable to the existing Si4831/35 tuner, requires a simple application circuit, and removes any requirements for manually tuning components during the manufacturing process. It is a very simple product to design, manufacture, and support across multiple product lines. The receiver has very low power consumption, runs off two AAA batteries, and delivers the performance benefits of digital tuning to the analog radio market.

Functional Block Diagram

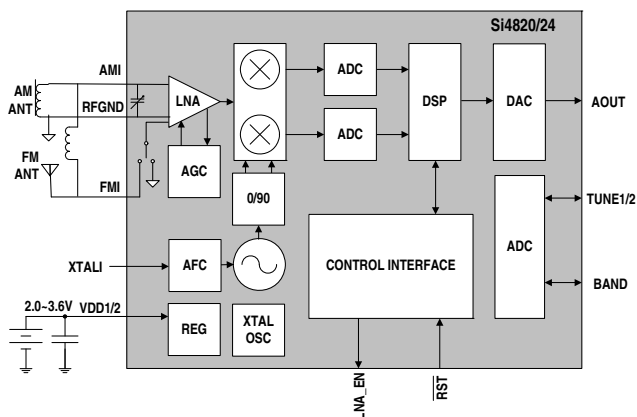

Pin Assignments

Si4820/24-A10 (SSOP)

LNA_EN	1	24	AOUT
NC	2	23	NC
TUNE1	3	22	DBYP
TUNE2	4	21	VDD2
BAND	5	20	VDD1
NC	6	19	XTALI
NC	7	18	XTALO
FMI	8	17	VOL-
RFGND	9	16	VOL+
NC	10	15	RST
NC	11	14	GND
AMI	12	13	GND

This product, its features, and/or its architecture is covered by one or more of the following patents, as well as other patents, pending and issued, both foreign and domestic: 7,127,217; 7,272,373; 7,272,375; 7,321,324; 7,355,476; 7,426,376; 7,471,940; 7,339,503; 7,339,504.

TABLE OF CONTENTS

<u>Section</u>	<u>Page</u>
1. Electrical Specifications	4
2. Typical Application Schematic	9
3. Bill of Materials	10
4. Functional Description	11
4.1. Overview	11
4.2. FM Receiver	11
4.3. AM Receiver	12
4.4. SW Receiver	12
4.5. Frequency Tuning	12
4.6. Band Select	12
4.7. Volume Control	12
5. Pin Descriptions: Si4820/24-A10	13
6. Ordering Guide	14
7. Package Outline: Si4820/24-A10	15
8. PCB Land Pattern: Si4820/24-A10	16
9. Top Markings	17
9.1. Si4820/24-A10 Top Markings	17
9.2. Top Marking Explanation	17
10. Additional Reference Resources	18
Contact Information	20

Si4820/24-A10

1. Electrical Specifications

Table 1. Recommended Operating Conditions^{1,2}

Parameter	Symbol	Test Condition	Min	Typ	Max	Unit
Supply Voltage ³	V_{DD}		2	—	3.6	V
Power Supply Powerup Rise Time	V_{DDRISE}		10	—	—	μ s

Note:

1. Typical values in the data sheet apply at $V_{DD} = 3.3$ V and 25 °C unless otherwise stated.
2. All minimum and maximum specifications in the data sheet apply across the recommended operating conditions for minimum $V_{DD} = 2.7$ V.
3. Operation at minimum V_{DD} is guaranteed by characterization when V_{DD} voltage is ramped down to 2.0 V. Part initialization may become unresponsive below 2.3 V.

Table 2. DC Characteristics

($V_{DD} = 2.7$ to 3.6 V, $T_A = 0$ to 70 °C)

Parameter	Symbol	Test Condition	Min	Typ	Max	Unit
FM Mode						
Supply Current*	I_{FM}		—	21.0	—	mA
AM/SW Mode						
Supply Current*	I_{AM}		—	17.0	—	mA
Supplies and Interface						
V_{DD} Powerdown Current	I_{DDPD}		—	10	—	μ A

***Note:** Specifications are guaranteed by characterization.

Table 3. Reset Timing Characteristics $(V_{DD} = 2.7 \text{ to } 3.6 \text{ V, } T_A = 0 \text{ to } 70 \text{ }^\circ\text{C})$

Parameter	Symbol	Min	Typ	Max	Unit
$\overline{\text{RST}}$ Pulse Width	t_{SRST}	100	—	—	μs

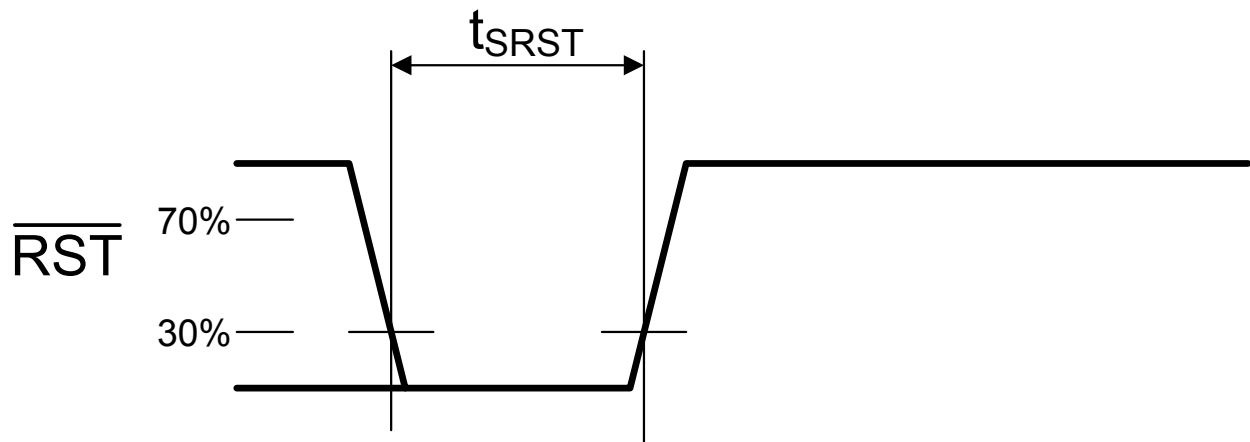
**Figure 1. Reset Timing**

Si4820/24-A10

Table 4. FM Receiver Characteristics^{1,2}

(V_{DD} = 2.7 to 3.6 V, TA = 0 to 70 °C)

Parameter	Symbol	Test Condition	Min	Typ	Max	Unit
Input Frequency	f _{RF}		64	—	109	MHz
Sensitivity with Headphone Network ³		(S+N)/N = 26 dB	—	4.0	—	μV EMF
LNA Input Resistance ^{4,5}			—	4	—	kΩ
LNA Input Capacitance ^{4,5}			—	5	—	pF
AM Suppression ^{4,5,6,7}		m = 0.3	—	50	—	dB
Input IP ₃ ^{4,8}			—	105	—	dBμV EMF
Adjacent Channel Selectivity ⁴		±200 kHz	—	45	—	dB
Alternate Channel Selectivity ⁴		±400 kHz	—	60	—	dB
Audio Output Voltage ^{5,6,7}			—	72	—	mV _{RMS}
Audio Mono S/N ^{5,6,7,9,10}			—	45	—	dB
Audio Frequency Response Low		-3 dB	—	—	30	Hz
Audio Frequency Response High		-3 dB	15	—	—	kHz
Audio THD ^{6,5,11}			—	0.1	0.5	%
Audio Output Load Resistance ^{4,10}	R _L	Single-ended	10	—	—	kΩ
Audio Output Load Capacitance ^{4,10}	C _L	Single-ended	—	—	50	pF
Powerup/Band Switch Time ⁴			—	—	110	ms

Notes:

1. Additional testing information is available in “AN569: Si4831/35/20/24-DEMO Board Test Procedure.” Volume = maximum for all tests. Tested at RF = 98.1 MHz.
2. To ensure proper operation and receiver performance, follow the guidelines in “AN555: Si483x-B/Si4820/24 Antenna, Schematic, Layout, and Design Guidelines.” Silicon Laboratories will evaluate schematics and layouts for qualified customers.
3. Frequency is 64~109 MHz.
4. Guaranteed by characterization.
5. V_{EMF} = 1 mV.
6. F_{MOD} = 1 kHz, MONO, and L = R unless noted otherwise.
7. Δf = 22.5 kHz.
8. |f₂ - f₁| > 2 MHz, f₀ = 2 x f₁ - f₂.
9. B_{AF} = 300 Hz to 15 kHz, A-weighted.
10. At A_{OUT} pin.
11. Δf = 75 kHz.

Table 5. AM/SW Receiver Characteristics^{1, 2}(V_{DD} = 2.7 to 3.6 V, T_A = 0 to 70 °C)

Parameter	Symbol	Test Condition	Min	Typ	Max	Unit
Input Frequency	f _{RF}	Medium Wave (AM)	504	—	1750	kHz
		Short Wave (SW)	5.60	—	22.0	MHz
Sensitivity ^{3,4,5}		(S+N)/N = 26 dB	—	30	—	μV EMF
Large Signal Voltage Handling ⁵		THD < 8%	—	300	—	mV _{RMS}
Power Supply Rejection Ratio ⁵		ΔV _{DD} = 100 mV _{RMS} , 100 Hz	—	40	—	dB
Audio Output Voltage ^{3,6}			—	54	—	mV _{RMS}
Audio S/N ^{3,4,6}			—	45	—	dB
Audio THD ^{3,6}			—	0.1	—	%
Antenna Inductance ^{5,7}			180	—	450	μH
Powerup/Band Switch Time ⁵		From powerdown	—	—	110	ms

Notes:

1. Additional testing information is available in “AN569: Si4831/35/20/24-DEMO Board Test Procedure.” Volume = maximum for all tests. Tested at RF = 520 kHz.
2. To ensure proper operation and receiver performance, follow the guidelines in “AN555: Si483x-B/Si4820/24 Antenna, Schematic, Layout, and Design Guidelines.” Silicon Laboratories will evaluate schematics and layouts for qualified customers.
3. F_{MOD} = 1 kHz, 30% modulation, 2 kHz channel filter.
4. B_{AF} = 300 Hz to 15 kHz, A-weighted.
5. Guaranteed by characterization.
6. V_{IN} = 5 mV_{rms}.
7. Stray capacitance on antenna and board must be < 10 pF to achieve full tuning range at higher inductance levels.

Table 6. Reference Clock and Crystal Characteristics(V_{DD} = 2.7 to 3.6 V, T_A = 0 to 70 °C)

Parameter	Symbol	Test Condition	Min	Typ	Max	Unit
Reference Clock						
XTALI Supported Reference Clock Frequencies			—	32.768	—	kHz
Reference Clock Frequency Tolerance for XTALI			-100	—	100	ppm
Crystal Oscillator						
Crystal Oscillator Frequency			—	32.768	—	kHz
Crystal Frequency Tolerance			-100	—	100	ppm
Board Capacitance			—	—	3.5	pF

Table 7. Thermal Conditions

Parameter	Symbol	Min	Typ	Max	Unit
Thermal Resistance*	θ_{JA}	—	80	—	°C/W
Ambient Temperature	T_A	0	25	70	°C
Junction Temperature	T_J	—	—	77	°C

***Note:** Thermal resistance assumes a multi-layer PCB with the exposed pad soldered to a topside PCB pad.

Table 8. Absolute Maximum Ratings^{1,2}

Parameter	Symbol	Value	Unit
Supply Voltage	V_{DD}	-0.5 to 5.8	V
Input Current ³	I_{IN}	10	mA
Operating Temperature	T_{OP}	-40 to 95	°C
Storage Temperature	T_{STG}	-55 to 150	°C
RF Input Level ⁴		0.4	V_{PK}

Notes:

1. Permanent device damage may occur if the above Absolute Maximum Ratings are exceeded. Functional operation should be restricted to the conditions as specified in the operational sections of this data sheet. Exposure beyond recommended operating conditions for extended periods may affect device reliability.
2. The Si4820/24-A10 devices are high-performance RF integrated circuits with certain pins having an ESD rating of < 2 kV HBM. Handling and assembly of these devices should only be done at ESD-protected workstations.
3. For input pins RST, VOL+, VOL-, XTALO, XTALI, BAND, TUNE2, TUNE1, LNA_EN.
4. At RF input pins, FMI and AMI.

2. Typical Application Schematic

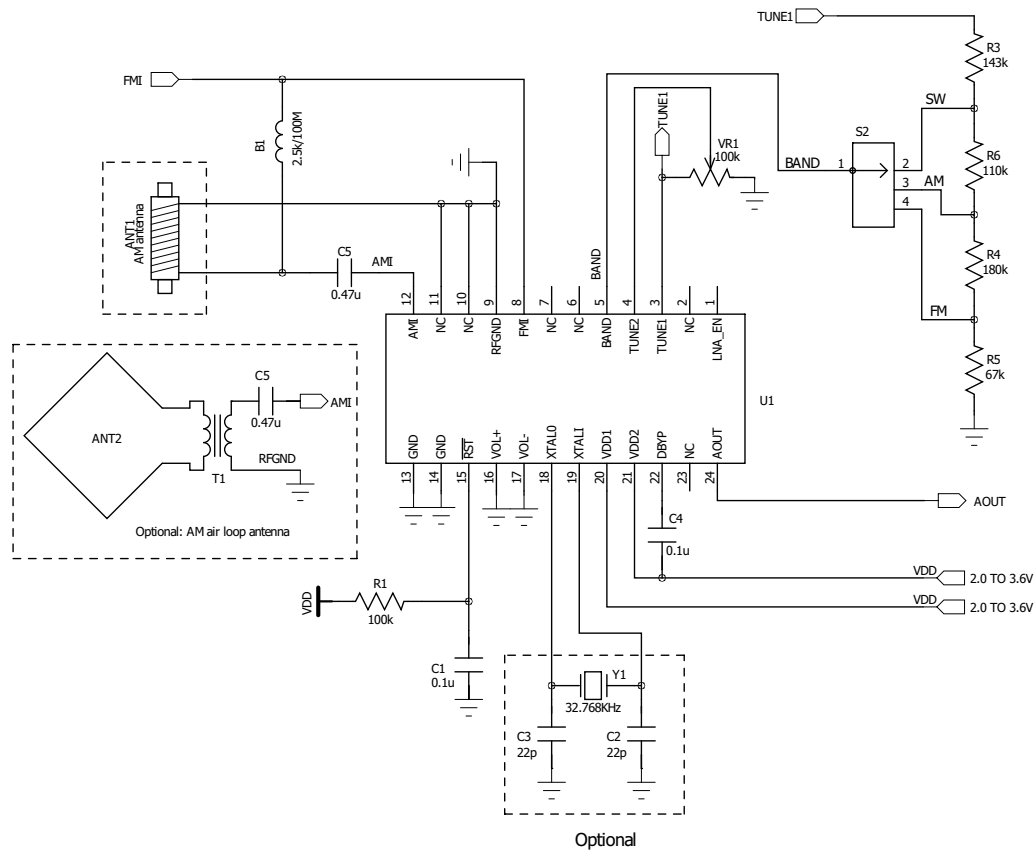

Notes:

1. Place C_4 close to V_{DD2} and DBYP pins.
2. All grounds connect directly to GND plane on PCB.
3. Pin 6, pin 7, and pin 23 leave floating.
4. To ensure proper operation and receiver performance, follow the guidelines in "AN555: Si483x-B/Si4820/24 Antenna, Schematic, Layout, and Design Guidelines." Silicon Labs will evaluate the schematics and layouts for qualified customers.
5. Pin 8 connects to the FM antenna interface and pin 12 connects to the AM antenna interface.
6. Place Si4820/24 as close as possible to antenna jack and keep the FMI and AMI traces as short as possible.
7. Recommend keeping the AM ferrite loop antenna at least 5 cm away from the MCU, audio AMP, and other circuits which have AM interference.
8. Keep the AM ferrite loop antenna at least 5 cm away from MCU, audio AMP, and other circuits which have AM interference.
9. Place the transformer T1 away from any sources of interference and even away from the I/O signals of the Si4820/24.

Si4820/24-A10

3. Bill of Materials

Table 9. Si4820/24-A Bill of Materials

Component(s)	Value/Description	Supplier
C1	Reset capacitor 0.1 μ F, \pm 20%, Z5U/X7R	Murata
C4	Supply bypass capacitor, 0.1 μ F, \pm 20%, Z5U/X7R	Murata
C5	Coupling capacitor, 0.47 μ F, \pm 20%, Z5U/X7R	Murata
B1	Ferrite bead 2.5 k/100 MHz	Murata
VR1	Variable resistor (POT), 100 k, \pm 10%	Kennon
R1	Reset timing resistor, 100 k, \pm 5%	Venkel
R3	Resistor, 143 k, \pm 1%,	Venkel
R4	Resistor, 180 k, \pm 1%	Venkel
R5	Resistor, 67 k, \pm 1%	Venkel
R6	Resistor, 110 k, \pm 1%	Venkel
U1	Si4820/24-A AM/FM/SW Analog Tune Analog Display Radio Tuner	Silicon Laboratories
S2	Band switch	Any, depends on customer
ANT1	Ferrite stick, 180-450 μ H	Jiaxin
Optional Components		
C2, C3	Crystal load capacitors, 22 pF, \pm 5%, COG (Optional: for crystal oscillator option)	Venkel
Y1	32.768 kHz crystal (Optional: for crystal oscillator option)	Epson or equivalent
ANT2	Air loop antenna, 10-20 μ H	Various

4. Functional Description

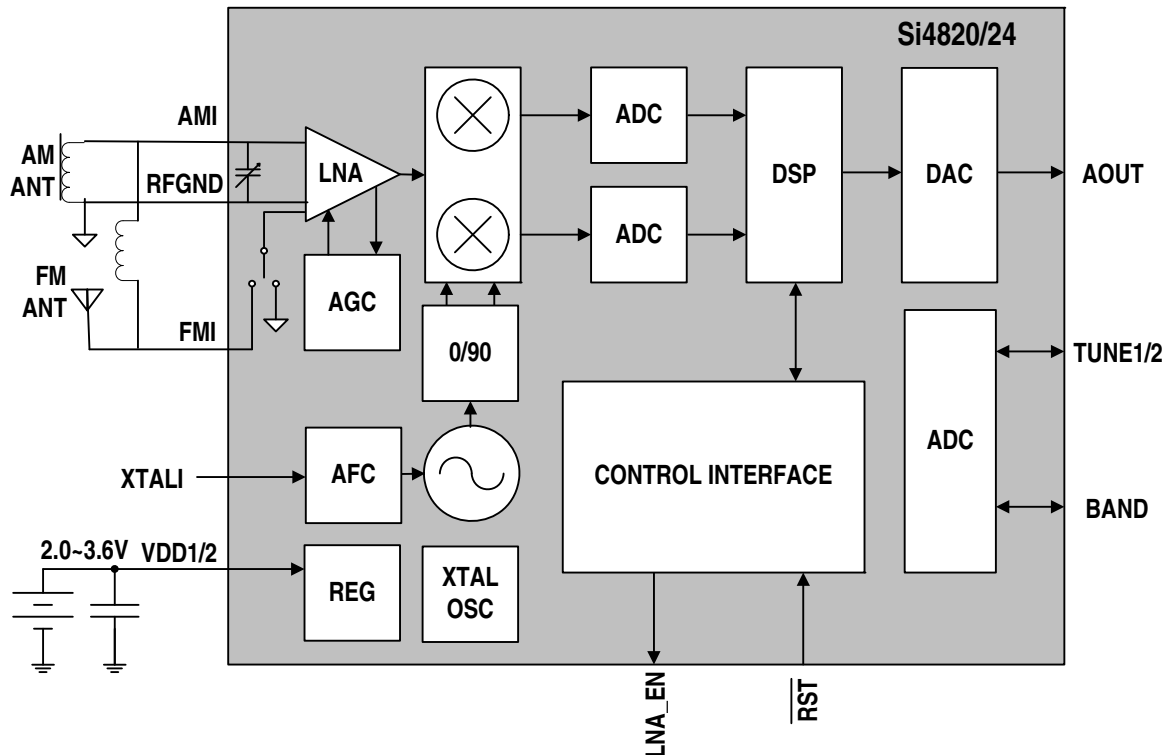

Figure 2. Si4820/24-A10 Functional Block Diagram

4.1. Overview

The Si4820/24-A10 is the entry level mechanical-tuned digital CMOS AM/FM/SW radio receiver IC that integrates the complete receiver function from antenna input to audio output. The Si4820/24-A10 extends Silicon Laboratories multi-band tuner family, and further increases the ease and attractiveness of design radio reception to audio devices through small size and board area, minimum component count, and superior, proven performance. The Si4820/24-A10 is drop-in replaceable to the existing Si4831/35 tuner, requires a simple application circuit, and removes any requirements for manually tuning components during the manufacturing process. It is a very simple product to design, manufacture, and support across multiple product lines.

Leveraging Silicon Laboratories' proven and patented digital low intermediate frequency (low-IF) receiver architecture, the Si4820/24-A10 delivers desired RF performance and interference rejection in AM, FM, and SW bands. The high integration and complete system production test simplifies design-in, increases system quality, and improves manufacturability.

4.2. FM Receiver

The Si4820/24-A10 integrates a low noise amplifier (LNA) supporting the worldwide FM broadcast band (64 to 109 MHz).

Pre-emphasis and de-emphasis is a technique used by FM broadcasters to improve the signal-to-noise ratio of FM receivers by reducing the effects of high frequency interference and noise. When the FM signal is transmitted, a pre-emphasis filter is applied to accentuate the high audio frequencies. All FM receivers incorporate a de-emphasis filter which attenuates high frequencies to restore a flat frequency response. Two time constants are used in various regions. The de-emphasis time constant can be chosen to be 50 or 75 μ s.

4.3. AM Receiver

The highly integrated Si4820/24-A10 supports worldwide AM band reception from 504 to 1750 kHz with five sub-bands using a digital low-IF architecture with a minimum number of external components and no manual alignment required. This patented architecture allows for high-precision filtering, offering excellent selectivity and SNR with minimum variation across the AM band. Similar to the FM receiver, the Si4820/24-A10 optimizes sensitivity and rejection of strong interferers, allowing better reception of weak stations.

To offer maximum flexibility, the receiver supports a wide range of ferrite loop sticks from 180–450 μ H. An air loop antenna is supported by using a transformer to increase the effective inductance from the air loop. Using a 1:5 turn ratio inductor, the inductance is increased by 25 times and easily supports all typical AM air loop antennas, which generally vary between 10 and 20 μ H.

4.4. SW Receiver

The Si4824 supports 16 short wave (SW) band receptions from 5.60 to 22.0 MHz. Si4824 supports extensive short wave features such as minimal discrete components and no factory adjustments. The Si4824 supports using the FM antenna to capture short wave signals.

4.5. Frequency Tuning

A valid channel can be found by tuning the potentiometer that is connected to the TUNE1 and TUNE2 pin of the Si4820/24-A10 chip.

To offer easy tuning, the Si4820/24-A10 also supports a station LED light. It will light up the LED if the RF signal quality passes the LED sensitivity threshold when tuned to a valid station.

4.6. Band Select

The Si4820/24-A10 supports worldwide AM band with five sub-bands, US/Europe/Japan/China FM band with five sub-bands, and SW band with 16 sub-bands. For details on band selection, refer to "AN555: Si483x-B/Si4820/24 Antenna, Schematic, Layout, and Design Guidelines."

4.7. Volume Control

The Si4820/24-A10 not only allows customers to use the traditional PVR wheel volume control through an external speaker amplifier, it also supports direct digital volume control through pins 16 and pin 17 by using volume up and down buttons. Refer to "AN555: Si483x-B/Si4820/24 Antenna, Schematic, Layout, and Design Guidelines."

5. Pin Descriptions: Si4820/24-A10

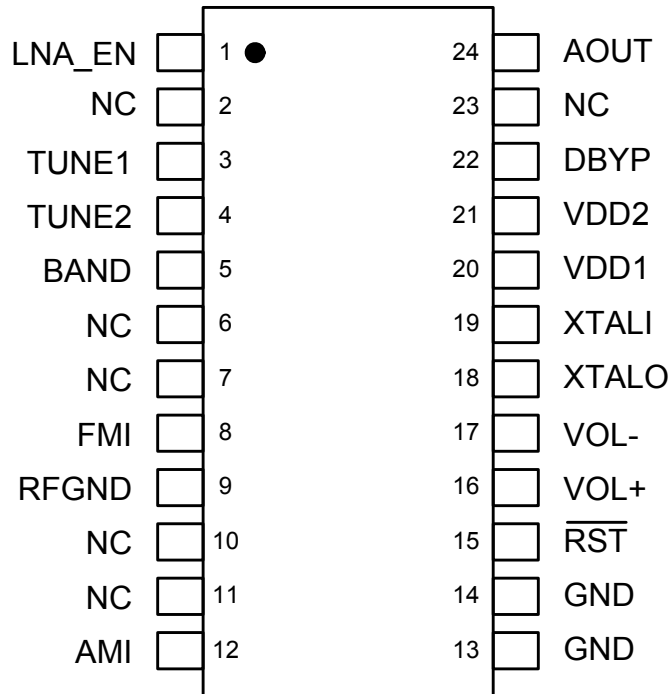

Pin Number(s)	Name	Description
1	LNA_EN	Enable SW external LNA for Si4824
2	NC	No connect
3	TUNE1	Frequency tuning
4	TUNE2	Frequency tuning
5	BAND	Band selection and de-emphasis selection
6,7	NC	No connect. Leave floating.
8	FMI	FM RF inputs. FMI should be connected to the antenna trace.
9	RFGND	RF ground. Connect to ground plane on PCB.
10,11	NC	Unused. Tie these pins to GND.
12	AMI	AM RF input. AMI should be connected to the AM antenna.
13,14	GND	Ground. Connect to ground plane on PCB.
15	$\overline{\text{RST}}$	Device reset (active low) input
16	VOL+	Volume button up
17	VOL-	Volume button down
18	XTALO	Crystal oscillator output
19	XTALI	Crystal oscillator input
20	VDD1	Supply voltage. May be connected directly to battery.
21	VDD2	Supply voltage. May be connected directly to battery.
22	DBYP	Dedicated bypass for VDD
23	NC	No connect. Leave floating
24	AOUT	Audio output

6. Ordering Guide

Part Number ^{1,2}	Description	Package Type	Operating Temperature/Voltage
Si4820-A10-CU	AM/FM Broadcast Radio Receiver	24L SSOP Pb-free	0 to 70 °C 2.0 to 3.6 V
Si4824-A10-CU	AM/FM/SW Broadcast Radio Receiver	24L SSOP Pb-free	0 to 70 °C 2.0 to 3.6 V

Notes:

1. Add an "(R)" at the end of the device part number to denote tape and reel option. The devices will typically operate at 25 °C with degraded specifications for V_{DD} voltage ramped down to 2.0 V.
2. The -C suffix in the part number indicates Consumer Grade product. Please visit www.silabs.com to get more information on product grade specifications.

7. Package Outline: Si4820/24-A10

The 24-pin SSOP illustrates the package details for the Si4820/24-A10. Table 10 lists the values for the dimensions shown in the illustration.

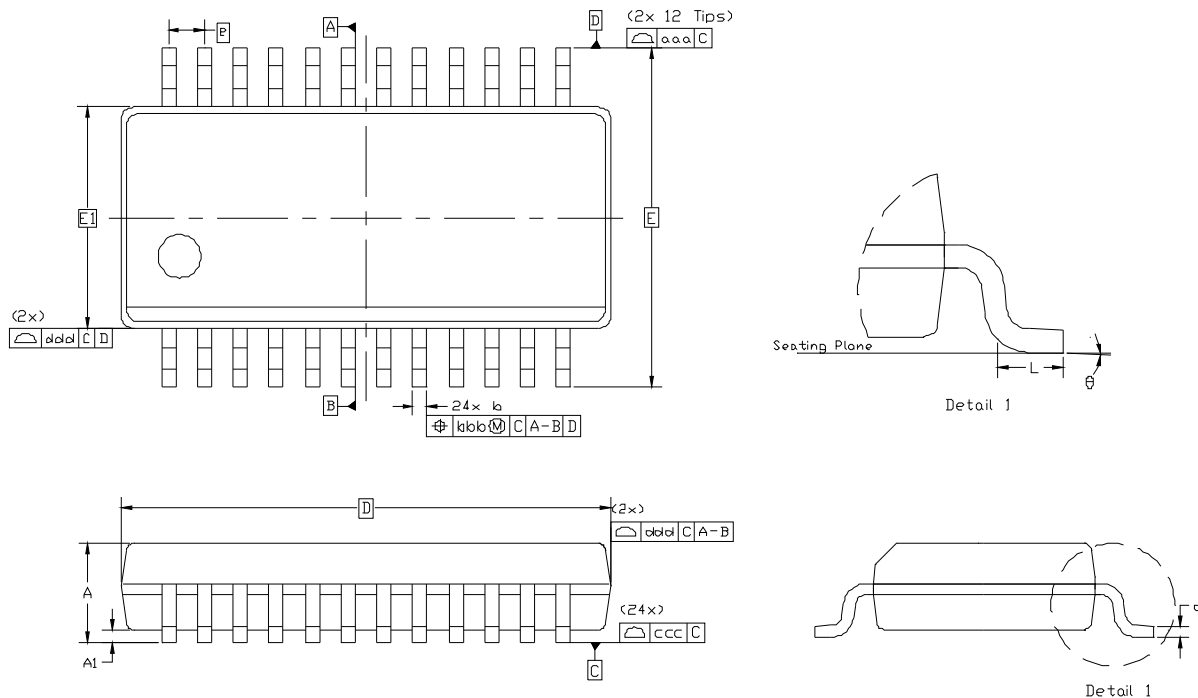

Figure 3. 24-Pin SSOP

Table 10. Package Dimensions

Dimension	Min	Nom	Max
A	—	—	1.75
A1	0.10	—	0.25
b	0.20	—	0.30
c	0.10	—	0.25
D	8.65 BSC		
E	6.00 BSC		
E1	3.90 BSC		
e	0.635 BSC		
L	0.40	—	1.27
θ	0°	—	8°
aaa	0.20		
bbb	0.18		
ccc	0.10		
ddd	0.10		
Notes:			
1. All dimensions shown are in millimeters (mm) unless otherwise noted.			
2. Dimensioning and Tolerancing per ANSI Y14.5M-1994.			
3. This drawing conforms to the JEDEC Solid State Outline MO-137, Variation AE.			
4. Recommended card reflow profile is per the JEDEC/IPC J-STD-020 specification for Small Body Components.			

8. PCB Land Pattern: Si4820/24-A10

Figure 4, “PCB Land Pattern,” illustrates the PCB land pattern details for the Si4820/24-A10-CU SSOP. Table 11 lists the values for the dimensions shown in the illustration.

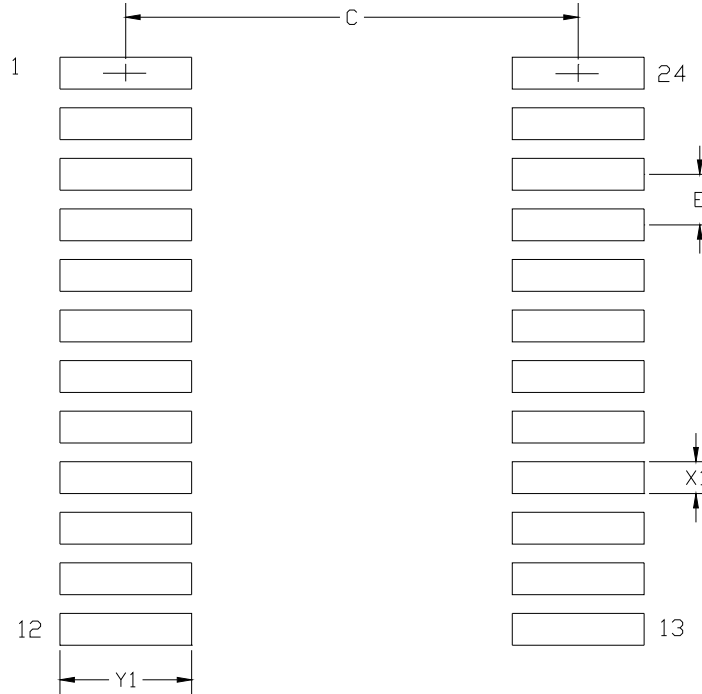

Figure 4. PCB Land Pattern

Table 11. PCB Land Pattern Dimensions

Dimension	Min	Max
C	5.20	5.40
E	0.635 BSC	
X1	0.35	0.45
Y1	1.55	1.75

General:

- All dimensions shown are in millimeters (mm) unless otherwise noted.
- This land pattern design is based on the IPC-7351 guidelines.

Solder Mask Design:

- All metal pads are to be non-solder mask defined (NSMD). Clearance between the solder mask and the metal pad is to be 60 μm minimum, all the way around the pad.

Stencil Design:

- A stainless steel, laser-cut, and electro-polished stencil with trapezoidal walls should be used to assure good solder paste release.
- The stencil thickness should be 0.125 mm (5 mils).
- The ratio of stencil aperture to land pad size should be 1:1 for all perimeter pads.

Card Assembly:

- A No-Clean, Type-3 solder paste is recommended.
- The recommended card reflow profile is per the JEDEC/IPC J-STD-020 specification for Small Body Components.

9. Top Marking

9.1. Si4820/24-A10 Top Marking

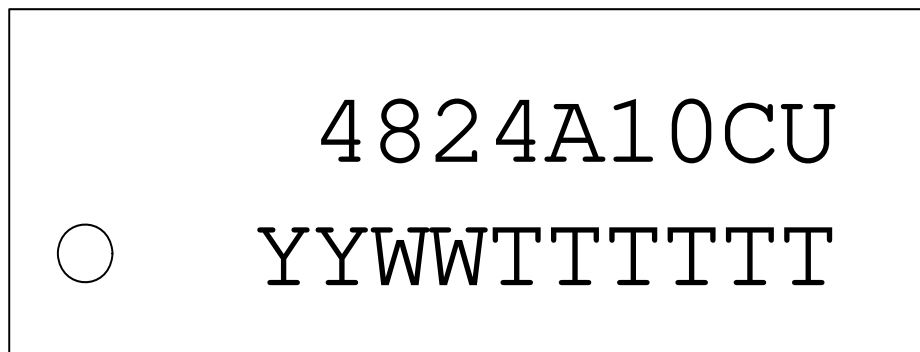
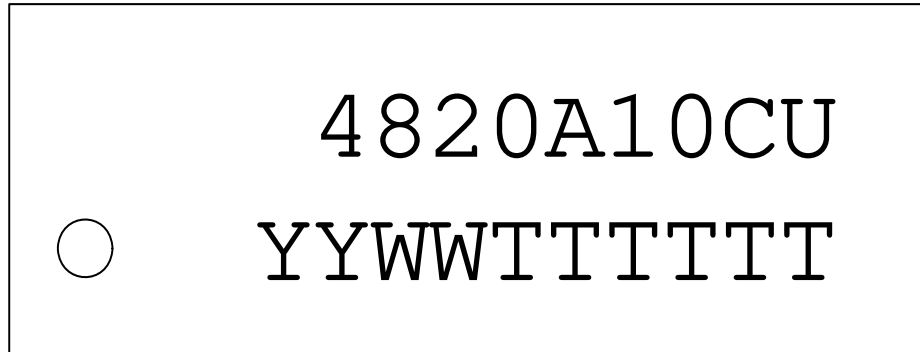

9.2. Top Marking Explanation

Mark Method:	YAG Laser	
Line 1 Marking:	Device identifier	4820A10CU = Si4820-A10 4824A10CU = Si4824-A10
Line 2 Marking:	YY = Year WW = Work week TTTTTT = Manufacturing code	Assigned by the Assembly House.

10. Additional Reference Resources

Contact your local sales representatives for more information or to obtain copies of the following references:

- AN555: Si483x-B/Si4820/24 Antenna, Schematic, Layout, and Design Guidelines
- AN569: Si4831/35/20/24-DEMO Board Test Procedure
- Si4820/24-DEMO Board User's Guide

NOTES:

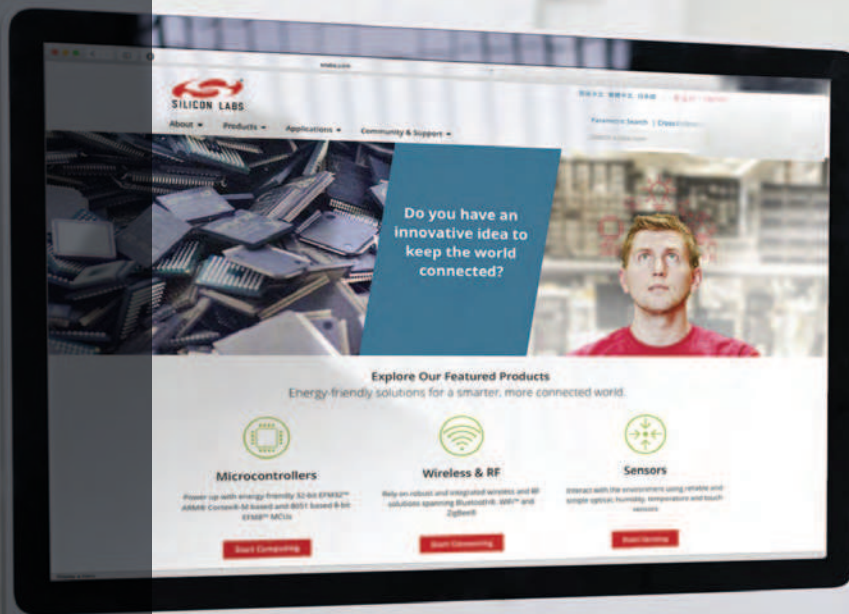

Smart.
Connected.
Energy-Friendly



Products
www.silabs.com/products

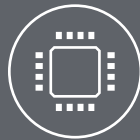

Quality
www.silabs.com/quality



Support and Community
community.silabs.com

Disclaimer

Silicon Laboratories intends to provide customers with the latest, accurate, and in-depth documentation of all peripherals and modules available for system and software implementers using or intending to use the Silicon Laboratories products. Characterization data, available modules and peripherals, memory sizes and memory addresses refer to each specific device, and "Typical" parameters provided can and do vary in different applications. Application examples described herein are for illustrative purposes only. Silicon Laboratories reserves the right to make changes without further notice and limitation to product information, specifications, and descriptions herein, and does not give warranties as to the accuracy or completeness of the included information. Silicon Laboratories shall have no liability for the consequences of use of the information supplied herein. This document does not imply or express copyright licenses granted hereunder to design or fabricate any integrated circuits. The products must not be used within any Life Support System without the specific written consent of Silicon Laboratories. A "Life Support System" is any product or system intended to support or sustain life and/or health, which, if it fails, can be reasonably expected to result in significant personal injury or death. Silicon Laboratories products are generally not intended for military applications. Silicon Laboratories products shall under no circumstances be used in weapons of mass destruction including (but not limited to) nuclear, biological or chemical weapons, or missiles capable of delivering such weapons.

Trademark Information

Silicon Laboratories Inc., Silicon Laboratories, Silicon Labs, SiLabs and the Silicon Labs logo, CMEMS®, EFM, EFM32, EFR, Energy Micro, Energy Micro logo and combinations thereof, "the world's most energy friendly microcontrollers", Ember®, EZLink®, EZMac®, EZRadio®, EZRadioPRO®, DSPLL®, ISOmodem®, Precision32®, ProSLIC®, SiPHY®, USBXpress® and others are trademarks or registered trademarks of Silicon Laboratories Inc. ARM, CORTEX, Cortex-M3 and THUMB are trademarks or registered trademarks of ARM Holdings. Keil is a registered trademark of ARM Limited. All other products or brand names mentioned herein are trademarks of their respective holders.



Silicon Laboratories Inc.
400 West Cesar Chavez
Austin, TX 78701
USA

<http://www.silabs.com>