



Chipsmall Limited consists of a professional team with an average of over 10 year of expertise in the distribution of electronic components. Based in Hongkong, we have already established firm and mutual-benefit business relationships with customers from,Europe,America and south Asia,supplying obsolete and hard-to-find components to meet their specific needs.

With the principle of “Quality Parts,Customers Priority,Honest Operation,and Considerate Service”,our business mainly focus on the distribution of electronic components. Line cards we deal with include Microchip,ALPS,ROHM,Xilinx,Pulse,ON,Everlight and Freescale. Main products comprise IC,Modules,Potentiometer,IC Socket,Relay,Connector.Our parts cover such applications as commercial,industrial, and automotives areas.

We are looking forward to setting up business relationship with you and hope to provide you with the best service and solution. Let us make a better world for our industry!



Contact us

Tel: +86-755-8981 8866 Fax: +86-755-8427 6832

Email & Skype: info@chipsmall.com Web: www.chipsmall.com

Address: A1208, Overseas Decoration Building, #122 Zhenhua RD., Futian, Shenzhen, China



Si52147 EVALUATION BOARD USER'S GUIDE

Description

The Si52147 is a nine port PCIe clock generator compliant to the PCIe Gen1, Gen2 and Gen3 standards. The Si52147 is a 48-pin QFN device that operates on a 3.3 V power supply and can be controlled using SMBus signals along with hardware control input pins. The differential outputs support spread spectrum and can be controlled through SSON input pin. The Si52147 needs a crystal or clock input of 25 MHz. The connections are described in this document.

EVB Features

This document is intended to be used in conjunction with the Si52147 device and data sheet for the following tests:

- PCIe Gen1, Gen2, Gen3 compliancy
- Power consumption test
- Jitter performance
- Testing out I²C code for signal tuning
- In-system validation where SMA connectors are present

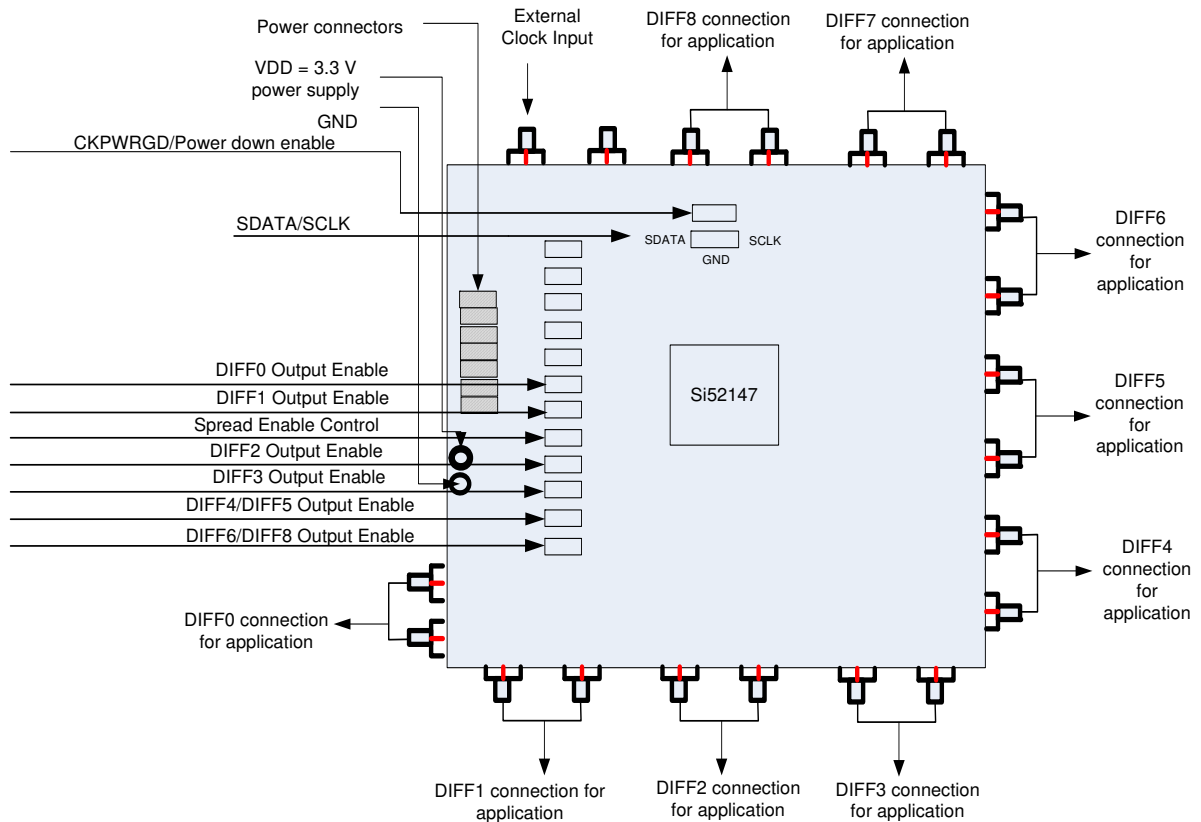

Si52147-EVB

1. Front Panel

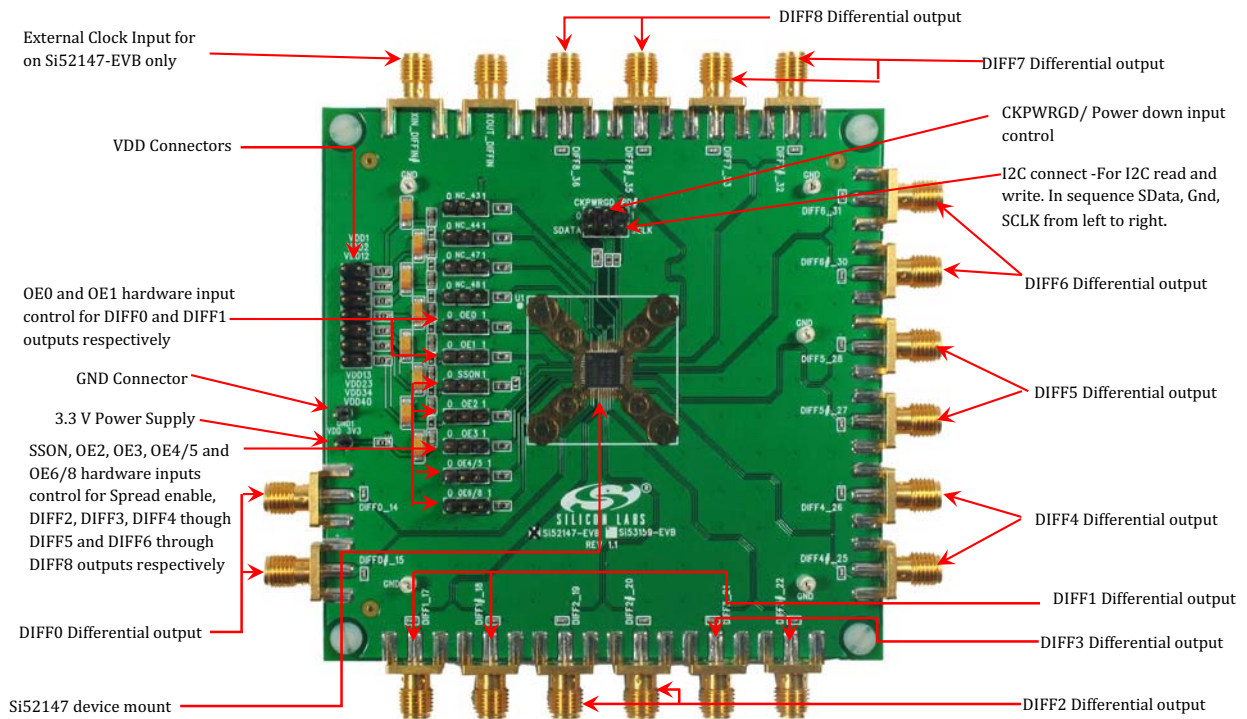

Figure 1. Evaluation Module Front Panel

Table 1. Input Jumper Settings

Jumper Label	Type	Description
OE0	I	OE0, 3.3 V Input for Enabling DIFF0 Clock Output. 1 = DIFF0 enabled, 0 = DIFF0 disabled.
OE1	I	OE1, 3.3 V Input for Enabling DIFF1 Clock Output. 1 = DIFF1 enabled, 0 = DIFF1 disabled.
OE2	I	OE2, 3.3 V Input for Enabling DIFF2 Clock Output. 1 = DIFF2 enabled, 0 = DIFF2 disabled.
OE3	I	OE3, 3.3 V Input for Enabling DIFF3 Clock Output. 1 = DIFF3 enabled, 0 = DIFF3 disabled.
OE4/5	I	OE4/5, 3.3 V Input for Enabling DIFF4 and DIFF5 Clock Outputs. 1 = DIFF4 & DIFF5 enabled, 0 = DIFF4 & DIFF5 disabled.
OE6/8	I	OE6/8, 3.3 V Input for Enabling DIFF6, DIFF7 and DIFF8 Clock Outputs. 1 = DIFF6, DIFF7 & DIFF8 enabled, 0 = DIFF6, DIFF7 & DIFF8 disabled.
CLKPWGD/ $\overline{\text{PD}}$	I	3.3 V LVTTTL Input. After CLKPWGD (active high) assertion, this pin becomes a real-time input for asserting power down (active low).

Table 1. Input Jumper Settings (Continued)

SSON	I	SSON Input, 3.3 V-Tolerant Active Input for Spread selection on the Output. Internal 100 k Ω pulldown. 1 = -0.5% Spread enabled, 0 = Spread disabled.
SDATA	I/O	SMBus-Compatible SDATA.
SCLK	I	SMBus-Compatible SCLOCK.

Table 2. Spread Selection

SSON	Frequency (MHz)	Spread (%)	Note
0	100.00	OFF	Default Value for SSON=0
1	100.00	-0.5	

Si52147-EVB

1.1. Generating DIFF Outputs from the Si52147

Upon power-on of the device, if the input pins are left floating, by default all DIFF outputs DIFF[0:8] are ON with 100 MHz and with spread spectrum disabled. The input pin headers have clear indication of jumper settings for setting logic low (0) and high (1) as shown below, the jumper placed on middle and left pin will set input OE0 to LOW; and jumper placed on middle and right pin will set input OE0 to high.

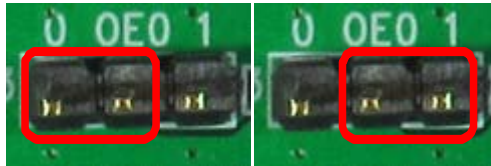

The output enable pins can be changed on the fly to observe outputs stopped cleanly. To enable the spread spectrum, the SSON input needs to change from a logic level low to high. Input functionality is explained in detail below.

1.1.1. SSON Input

Apply the appropriate logic level to SSON input to achieve clock frequency selection. When the SSON is high, -0.5% down spread is enabled on all differential outputs with a saw-tooth spread profile. When the SSON is low, spread profile is disabled.

1.1.2. OE [0:8] Input

The output enable pins can change on the fly when the device is on. Deasserting (valid low) results in corresponding DIFF output to be stopped after their next transition with final state low/low. Asserting (valid high) results in corresponding output that was stopped are to resume normal operation in a glitch-free manner.

Each of the hardware OE [0:8] pins are mapped via I²C to control bit in Control register. The hardware pin and the Register Control Bit both need to be high to enable the output. Both of these form an “AND” function to disable or enable the DIFF output. The DIFF outputs and their corresponding I²C control bits and hardware pins are listed in Table 3.

Table 3. Output Enable Control

I ² C Control Bit	Output	Hardware Control Input
Byte1 [bit 4]	DIFF0	OE0
Byte1 [bit 2]	DIFF1	OE1
Byte2 [bit 1]	DIFF2	OE2
Byte2 [bit 0]	DIFF3	OE3
Byte1 [bit 7]	DIFF4	OE4/5
Byte1 [bit 6]	DIFF5	OE4/5
Byte2 [bit 5]	DIFF6	OE6/8
Byte2 [bit 4]	DIFF7	OE6/8
Byte2 [bit 3]	DIFF8	OE6/8

2. Schematics

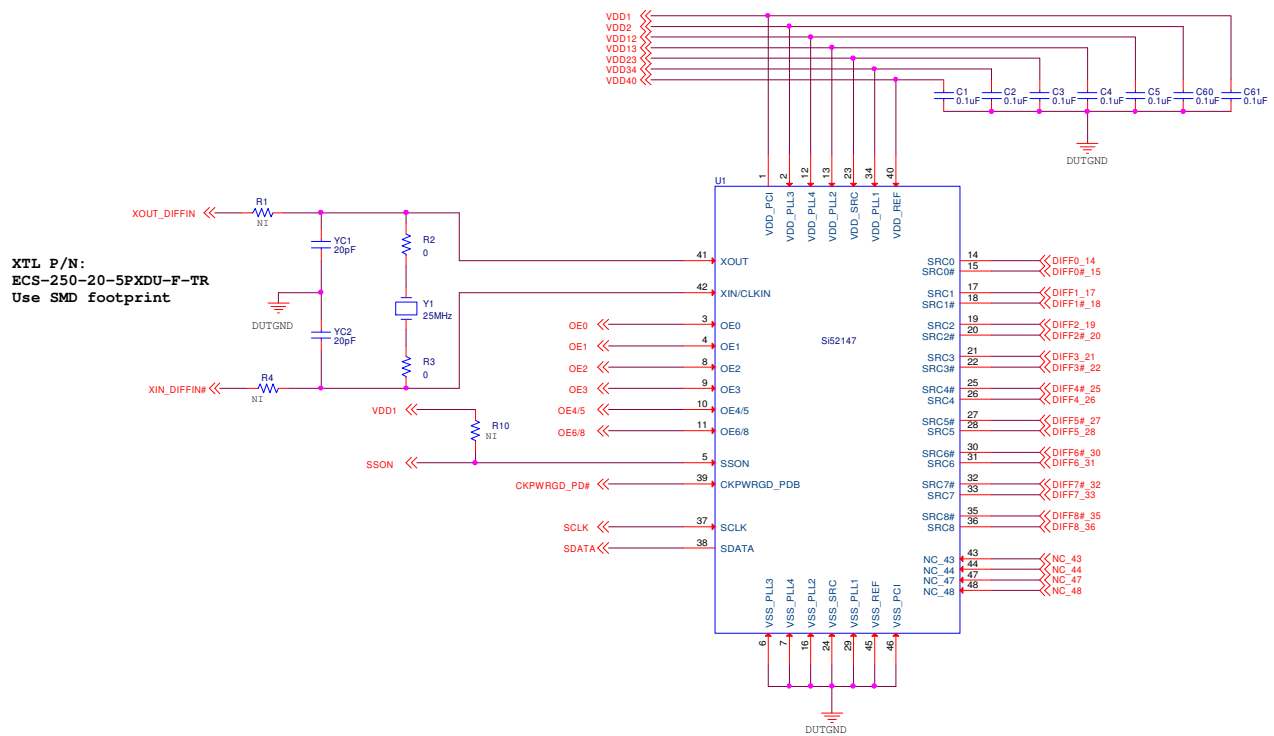

Figure 2. QFN-48 Device Connection

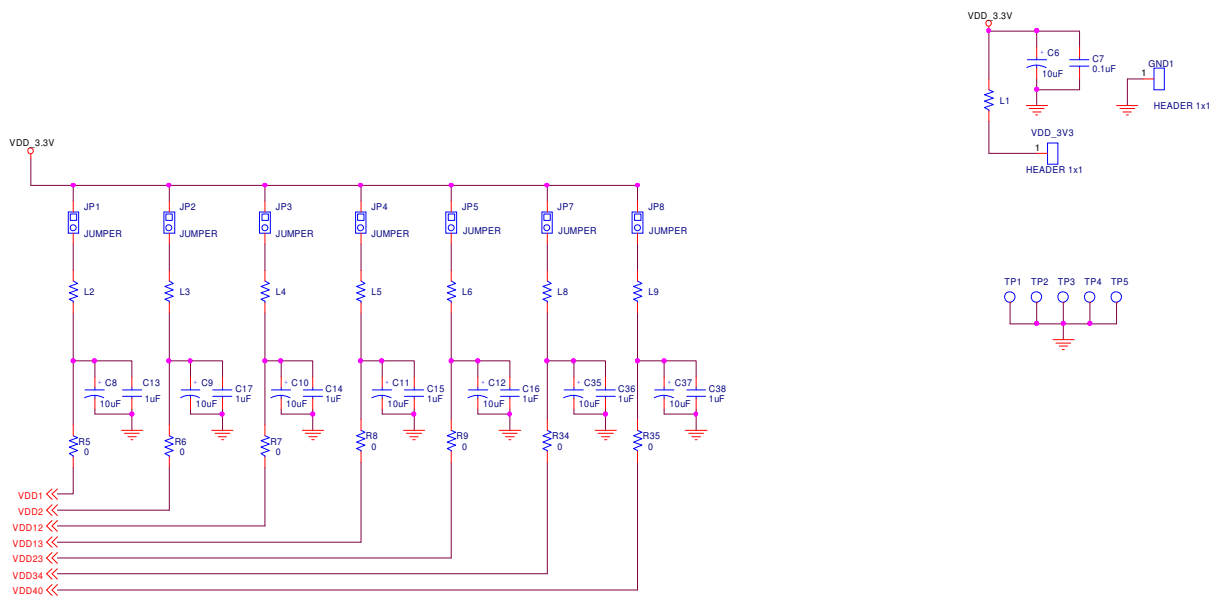

Figure 3. Device Power Supply

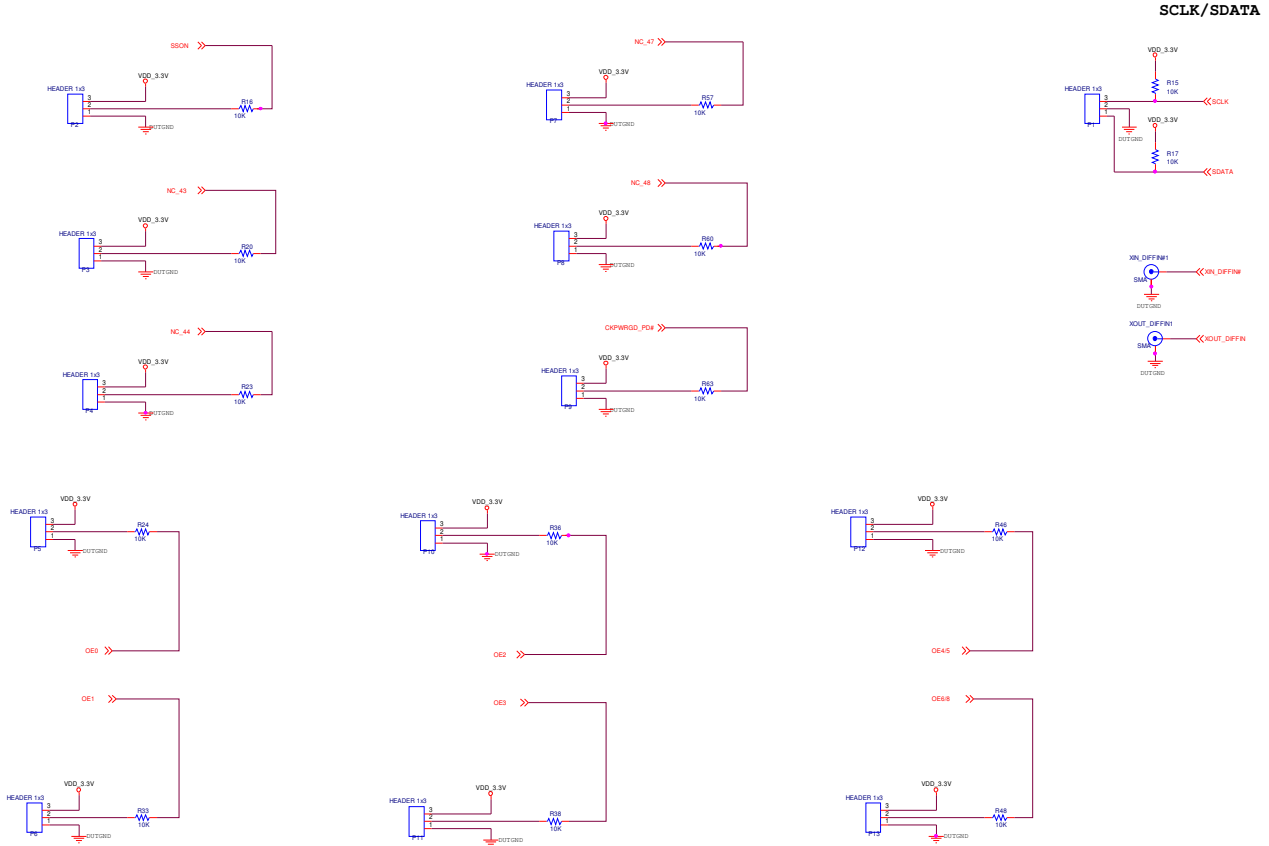

Figure 4. Clock and Control Signals

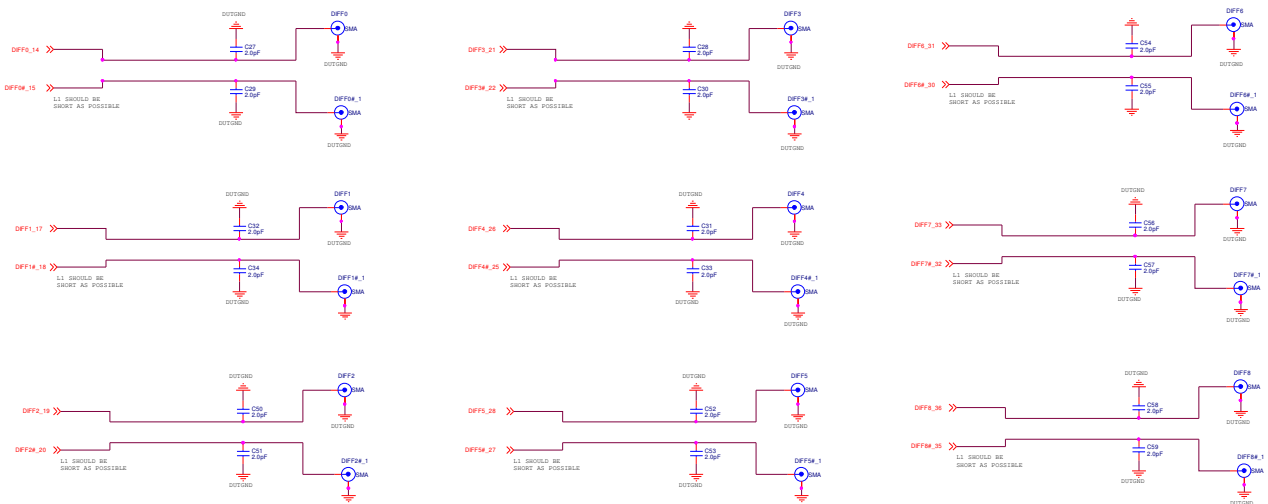

Figure 5. Differential Clock Signals

NOTES:



ClockBuilder Pro

One-click access to Timing tools, documentation, software, source code libraries & more. Available for Windows and iOS (CBGo only).

www.silabs.com/CBPro



Timing Portfolio
www.silabs.com/timing



SW/HW
www.silabs.com/CBPro



Quality
www.silabs.com/quality



Support and Community
community.silabs.com

Disclaimer

Silicon Laboratories intends to provide customers with the latest, accurate, and in-depth documentation of all peripherals and modules available for system and software implementers using or intending to use the Silicon Laboratories products. Characterization data, available modules and peripherals, memory sizes and memory addresses refer to each specific device, and "Typical" parameters provided can and do vary in different applications. Application examples described herein are for illustrative purposes only. Silicon Laboratories reserves the right to make changes without further notice and limitation to product information, specifications, and descriptions herein, and does not give warranties as to the accuracy or completeness of the included information. Silicon Laboratories shall have no liability for the consequences of use of the information supplied herein. This document does not imply or express copyright licenses granted hereunder to design or fabricate any integrated circuits. The products must not be used within any Life Support System without the specific written consent of Silicon Laboratories. A "Life Support System" is any product or system intended to support or sustain life and/or health, which, if it fails, can be reasonably expected to result in significant personal injury or death. Silicon Laboratories products are generally not intended for military applications. Silicon Laboratories products shall under no circumstances be used in weapons of mass destruction including (but not limited to) nuclear, biological or chemical weapons, or missiles capable of delivering such weapons.

Trademark Information

Silicon Laboratories Inc., Silicon Laboratories, Silicon Labs, SiLabs and the Silicon Labs logo, CMEMS®, EFM, EFM32, EFR, Energy Micro, Energy Micro logo and combinations thereof, "the world's most energy friendly microcontrollers", Ember®, EZLink®, EZMac®, EZRadio®, EZRadioPRO®, DSPLL®, ISOModem®, Precision32®, ProSLIC®, SiPHY®, USBXpress® and others are trademarks or registered trademarks of Silicon Laboratories Inc. ARM, CORTEX, Cortex-M3 and THUMB are trademarks or registered trademarks of ARM Holdings. Keil is a registered trademark of ARM Limited. All other products or brand names mentioned herein are trademarks of their respective holders.



SILICON LABS

Silicon Laboratories Inc.
400 West Cesar Chavez
Austin, TX 78701
USA

<http://www.silabs.com>