



Chipsmall Limited consists of a professional team with an average of over 10 year of expertise in the distribution of electronic components. Based in Hongkong, we have already established firm and mutual-benefit business relationships with customers from,Europe,America and south Asia,supplying obsolete and hard-to-find components to meet their specific needs.

With the principle of “Quality Parts,Customers Priority,Honest Operation,and Considerate Service”,our business mainly focus on the distribution of electronic components. Line cards we deal with include Microchip,ALPS,ROHM,Xilinx,Pulse,ON,Everlight and Freescale. Main products comprise IC,Modules,Potentiometer,IC Socket,Relay,Connector.Our parts cover such applications as commercial,industrial, and automotives areas.

We are looking forward to setting up business relationship with you and hope to provide you with the best service and solution. Let us make a better world for our industry!



Contact us

Tel: +86-755-8981 8866 Fax: +86-755-8427 6832

Email & Skype: info@chipsmall.com Web: www.chipsmall.com

Address: A1208, Overseas Decoration Building, #122 Zhenhua RD., Futian, Shenzhen, China



PIN-CONTROLLED 1–711 MHz JITTER CLEANING CLOCK

Features

- Provides jitter attenuation for any clock frequency
- One clock input / two clock outputs
- Input/output frequency range: 1–711 MHz
- Ultra low jitter: 300 fs (12 kHz–20 MHz) typical
- Simple pin control interface
- Selectable loop bandwidth for jitter attenuation: 60 Hz–8.4 kHz
- Meets OC-192 GR-253-CORE jitter specifications
- Selectable output clock signal format: LVPECL, LVDS, CML or CMOS
- Single supply: 1.8, 2.5, or 3.3 V
- Loss of lock and loss of signal alarms
- VCO freeze during LOS/LOL
- On-chip voltage regulator with high PSRR
- Small size: 6 x 6 mm, 36-QFN
- Wide temperature range: –40 to +85 °C

Applications

- Data converter clocking
- Wireless infrastructure
- Networking, SONET/SDH
- Switches and routers
- Medical instrumentation
- Test and measurement

Description

The Si5317 is a flexible 1:1 jitter cleaning clock for high-performance applications that require jitter attenuation without clock multiplication. The Si5317 accepts a single clock input ranging from 1 to 711 MHz and generates two low jitter clock outputs at the same frequency. The clock frequency range and loop bandwidth are selectable from a simple look-up table. The Si5317 is based on Silicon Laboratories' 3rd-generation DSPLL[®] technology, which provides jitter attenuation on any frequency in a highly integrated PLL solution that eliminates the need for external VCXO and loop filter components. The DSPLL loop bandwidth is user selectable, providing jitter performance optimization at the application level.

Functional Block Diagram

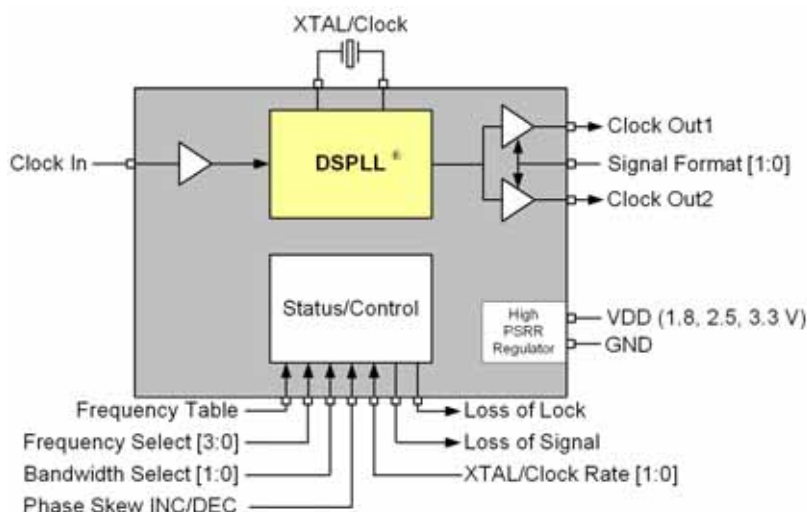

Ordering Information:

See page 40.

Pin Assignments

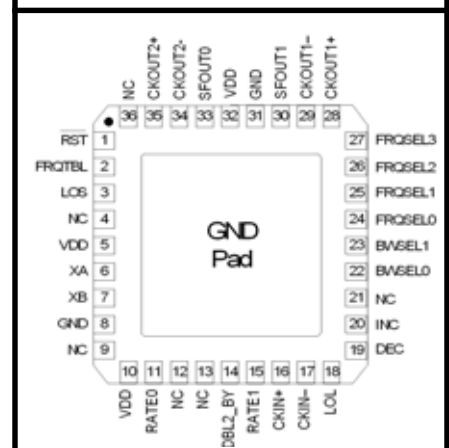

TABLE OF CONTENTS

<u>Section</u>	<u>Page</u>
1. Electrical Specifications	4
1.1. Three-Level (3L) Input Pins (No External Resistors)	9
1.2. Three-Level Input Pins (Example with External Resistors)	9
2. Functional Description	14
2.1. Overview	14
3. Frequency Plan Tables	15
3.1. Frequency Range Plan	15
3.2. Output Skew Adjustment	15
3.3. PLL Self-Calibration	22
3.4. Alarms	23
3.5. VCO Freeze	23
3.6. PLL Bypass Mode	24
4. High-Speed I/O	25
4.1. Input Clock Buffer	25
4.2. Output Clock Driver	27
5. Crystal/Reference Clock Input	29
5.1. Crystal/Reference Clock Selection	30
6. Power Supply Filtering	33
7. Typical Phase Noise Plots	34
7.1. Example: SONET OC-192	34
8. Typical Application Circuit	35
9. Pin Descriptions: Si5317	36
10. Ordering Guide	40
11. Package Outline: 36-Pin QFN	41
12. Recommended PCB Layout	42
13. Si5317 Device Top Mark	44
Document Change List	45
Contact Information	46

1. Electrical Specifications

Table 1. Recommended Operating Conditions

($V_{DD} = 1.8 \pm 5\%$, $2.5 \pm 10\%$, or $3.3 \text{ V} \pm 10\%$, $T_A = -40$ to $85 \text{ }^\circ\text{C}$)

Parameter	Symbol	Test Condition	Min	Typ	Max	Unit
Temperature Range	T_A		-40	25	85	$^\circ\text{C}$
Supply Voltage	V_{DD}	3.3 V nominal	2.97	3.3	3.63	V
		2.5 V nominal	2.25	2.5	2.75	V
		1.8 V nominal	1.71	1.8	1.89	V

Note: All minimum and maximum specifications are guaranteed and apply across the recommended operating conditions. Typical values apply at nominal supply voltages and an operating temperature of $25 \text{ }^\circ\text{C}$ unless otherwise noted.

Table 2. DC Characteristics

($V_{DD} = 1.8 \pm 5\%$, $2.5 \pm 10\%$, or $3.3 \text{ V} \pm 10\%$, $T_A = -40$ to $85 \text{ }^\circ\text{C}$)

Parameter	Symbol	Test Condition	Min	Typ	Max	Units
Supply Current (Supply current is independent of V_{DD})	I_{DD}	LVPECL Format 622.08 MHz Out All CKOUTs Enabled ¹	—	251	279	mA
		LVPECL Format 622.08 MHz Out Only 1 CKOUT Enabled ¹	—	217	243	mA
		CMOS Format 19.44 MHz Out All CKOUTs Enabled ²	—	204	234	mA
		CMOS Format 19.44 MHz Out Only CKOUT1 Enabled ²	—	194	220	mA

CKIN Input Pin

Input Common Mode Voltage (Input Threshold Voltage)	V_{ICM}	$1.8 \text{ V} \pm 5\%$	0.9	—	1.4	V
		$2.5 \text{ V} \pm 10\%$	1.0	—	1.7	V
		$3.3 \text{ V} \pm 10\%$	1.1	—	1.95	V
Input Resistance	CKN_{RIN}	Single-ended	20	40	60	$\text{k}\Omega$
Input Voltage Level Limits	CKN_{VIN}	See note ³	0	—	V_{DD}	V
Single-ended Input Voltage Swing	V_{ISE}	$f_{CKIN} \leq 212.5 \text{ MHz}$ See Figure 2.	0.2	—	—	V_{PP}
		$f_{CKIN} > 212.5 \text{ MHz}$ See Figure 2.	0.25	—	—	V_{PP}

Notes:

1. LVPECL outputs require $V_{DD} \geq 2.25 \text{ V}$.
2. This is the amount of leakage that the 3L inputs can tolerate from an external driver. See Figure 3 on page 9. In most designs, an external resistor voltage divider is recommended.
3. No overshoot or undershoot.

Table 2. DC Characteristics (Continued) $(V_{DD} = 1.8 \pm 5\%, 2.5 \pm 10\%, \text{ or } 3.3 \text{ V} \pm 10\%, T_A = -40 \text{ to } 85 \text{ }^\circ\text{C})$

Parameter	Symbol	Test Condition	Min	Typ	Max	Units
Differential Input Voltage Swing	V_{ID}	$f_{CKIN} \leq 212.5 \text{ MHz}$ See Figure 2.	0.2	—	—	V_{PP}
		$f_{CKIN} > 212.5 \text{ MHz}$ See Figure 2.	0.25	—	—	V_{PP}
CKOUT Output Clock¹						
Common Mode	V_{OCM}	LVPECL 100 Ω load line-to-line	$V_{DD} - 1.42$	—	$V_{DD} - 1.25$	V
Differential Output Swing	V_{OD}	LVPECL 100 Ω load line-to-line	1.1	—	1.9	V_{PP}
Single-ended Output Swing	V_{SE}	LVPECL 100 Ω load line-to-line	0.5	—	0.93	V_{PP}
Differential Output Voltage	CKO_{VD}	CML 100 Ω load line-to-line	350	425	500	mV_{PP}
Common Mode Output Voltage	CKO_{VCM}	CML 100 Ω load line-to-line	—	$V_{DD} - 0.36$	—	V
Differential Output Voltage	CKO_{VD}	LVDS 100 Ω load line-to-line	500	700	900	mV_{PP}
		Low swing LVDS 100 Ω load line-to-line	350	425	500	mV_{PP}
Common Mode Output Voltage	CKO_{VCM}	LVDS 100 Ω load line-to-line	1.125	1.2	1.275	V
Output Voltage Low	CKO_{VOLLH}	CMOS	—	—	0.4	V
Output Voltage High	CKO_{VOHLH}	$V_{DD} = 1.71 \text{ V}$ CMOS	$0.8 \times V_{DD}$	—	—	V
Output Drive Current	CKO_{IO}	CMOS Driving into CKO_{VOL} for out- put low or CKO_{VOH} for output high. CKOUT+ and CKOUT- shorted externally.				
		$V_{DD} = 1.8 \text{ V}$	—	7.5	—	mA
		$V_{DD} = 3.3 \text{ V}$	—	32	—	mA
2-Level LVCMOS Input Pins						
Input Voltage Low	V_{IL}	$V_{DD} = 1.71 \text{ V}$	—	—	0.5	V
		$V_{DD} = 2.25 \text{ V}$	—	—	0.7	V
		$V_{DD} = 2.97 \text{ V}$	—	—	0.8	V
Notes:						
1. LVPECL outputs require $V_{DD} \geq 2.25 \text{ V}$.						
2. This is the amount of leakage that the 3L inputs can tolerate from an external driver. See Figure 3 on page 9. In most designs, an external resistor voltage divider is recommended.						
3. No overshoot or undershoot.						

Table 2. DC Characteristics (Continued)

($V_{DD} = 1.8 \pm 5\%$, $2.5 \pm 10\%$, or $3.3 \text{ V} \pm 10\%$, $T_A = -40$ to $85 \text{ }^\circ\text{C}$)

Parameter	Symbol	Test Condition	Min	Typ	Max	Units
Input Voltage High	V_{IH}	$V_{DD} = 1.89 \text{ V}$	1.4	—	—	V
		$V_{DD} = 2.25 \text{ V}$	1.8	—	—	V
		$V_{DD} = 3.63 \text{ V}$	2.5	—	—	V
Input Low Current	I_{IL}		—	—	50	μA
Input High Current	I_{IH}		—	—	50	μA
Weak Internal Input Pull-up Resistor	R_{PUP}		—	75	—	$\text{k}\Omega$
Weak Internal Input Pull-down Resistor	R_{PDN}		—	75	—	$\text{k}\Omega$
3-Level Input Pins						
Input Voltage Low	V_{ILL}		—	—	$0.15 \times V_{DD}$	V
Input Voltage Mid	V_{IMM}		$0.45 \times V_{DD}$	—	$0.55 \times V_{DD}$	V
Input Voltage High	V_{IHH}		$0.85 \times V_{DD}$	—	—	V
Input Low Current	I_{ILL}^2		-20	—	—	μA
Input Mid Current	I_{IMM}^2		-2	—	2	μA
Input High Current	I_{IHH}^2		—	—	20	μA
Notes:						
1. LVPECL outputs require $V_{DD} \geq 2.25 \text{ V}$.						
2. This is the amount of leakage that the 3L inputs can tolerate from an external driver. See Figure 3 on page 9. In most designs, an external resistor voltage divider is recommended.						
3. No overshoot or undershoot.						

Table 2. DC Characteristics (Continued) $(V_{DD} = 1.8 \pm 5\%, 2.5 \pm 10\%, \text{ or } 3.3 \text{ V} \pm 10\%, T_A = -40 \text{ to } 85 \text{ }^\circ\text{C})$

Parameter	Symbol	Test Condition	Min	Typ	Max	Units
LVC MOS Output Pins						
Output Voltage Low	V_{OL}	$I_O = 2 \text{ mA}$ $V_{DD} = 1.62 \text{ V}$	—	—	0.4	V
		$I_O = 2 \text{ mA}$ $V_{DD} = 2.97 \text{ V}$	—	—	0.4	V
Output Voltage High	V_{OH}	$I_O = -2 \text{ mA}$ $V_{DD} = 1.62 \text{ V}$	$V_{DD} - 0.4$	—	—	V
		$I_O = -2 \text{ mA}$ $V_{DD} = 2.97 \text{ V}$	$V_{DD} - 0.4$	—	—	V
Single-Ended Reference Clock Input Pin XA (XB with cap to gnd)						
Input Resistance	XA_{RIN}	XTAL/RefCLK RATE[1:0] = LM, ML, MH, or HM	—	12	—	k Ω
Input Voltage Level Limits	XA_{VIN}		0	—	1.2	V
Input Voltage Swing	XA_{VPP}		0.5	—	1.2	V_{PP}
Differential Reference Clock Input Pins (XA/XB)						
Input Resistance	XA/XB_{RIN}	XTAL/RefCLK RATE[1:0] = LM, ML, MH, or HM	—	12	—	k Ω
Differential Input Voltage Level Limits	XA/XB_{VIN}		0	—	1.2	V
Input Voltage Swing	XA_{VPP}/XB_{VPP}		0.5	—	2.4	V_{PP}
Notes:						
1. LVPECL outputs require $V_{DD} \geq 2.25 \text{ V}$.						
2. This is the amount of leakage that the 3L inputs can tolerate from an external driver. See Figure 3 on page 9. In most designs, an external resistor voltage divider is recommended.						
3. No overshoot or undershoot.						

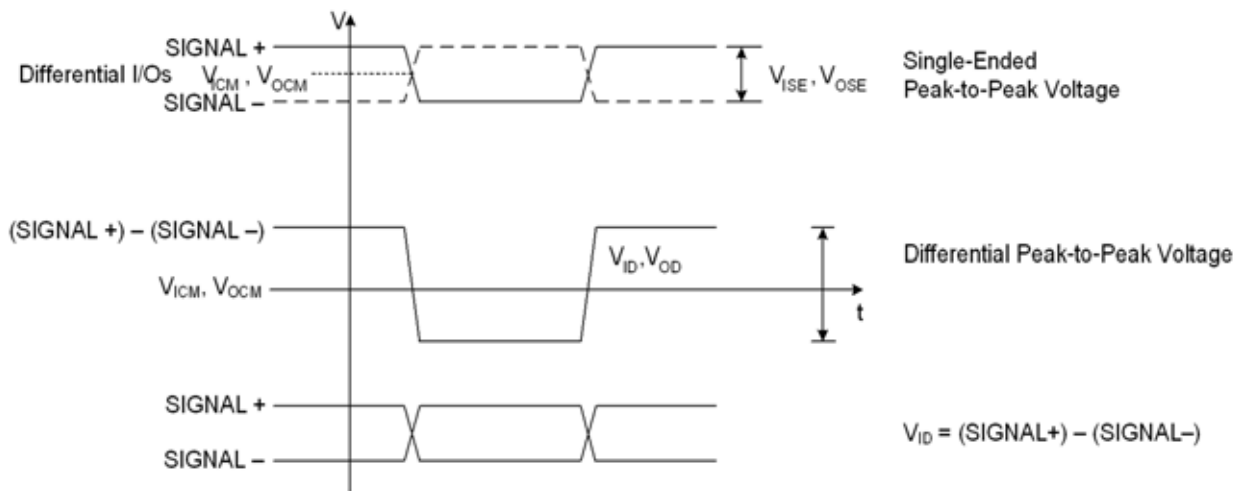

Figure 1. Voltage Characteristics

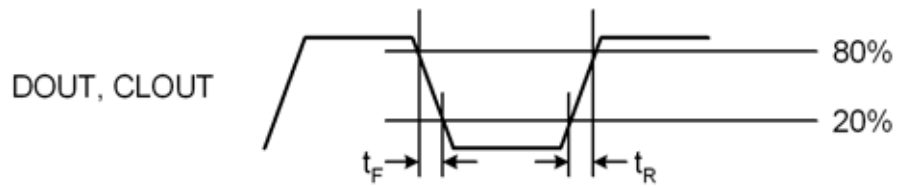

Figure 2. Rise/Fall Time Characteristics

1.1. Three-Level (3L) Input Pins (No External Resistors)

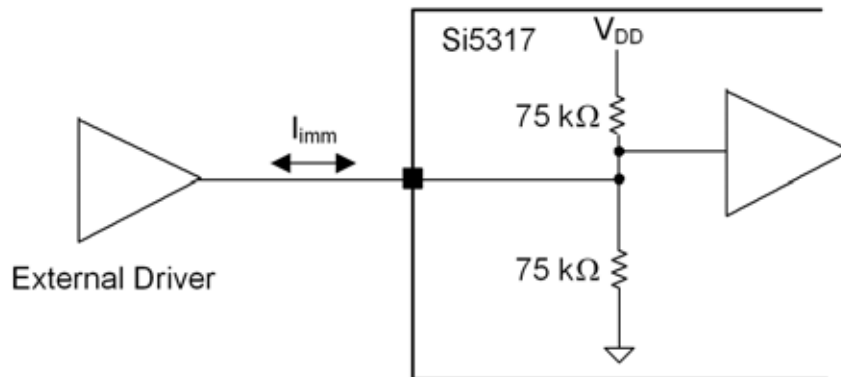
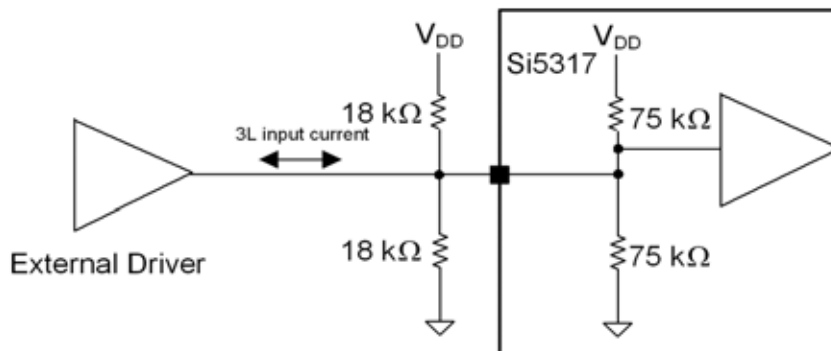

Figure 3. Three-Level Input Pins

1.2. Three-Level Input Pins (Example with External Resistors)



One of eight resistors from a Panasonic EXB-D10C183J (or similar) resistor pack

Figure 4. Three-Level Input Pins

Table 3. Three-Level Input Pins^{1,2,3,4}

Parameter	Min	Max
Input Low Current	-30 μ A	—
Input Mid Current	-11 μ A	-11 μ A
Input High Current	—	-30 μ A

Notes:

1. The current parameters are the amount of leakage that the 3L inputs can tolerate from an external driver using the external resistor values indicated in this example. In most designs, an external resistor voltage divider is recommended.
2. Resistor packs are only needed if the leakage current of the external driver exceeds the current specified in Table 2, I_{lim}. Any resistor pack may be used (e.g. Panasonic EXB-D10C183J). PCB layout is not critical.
3. If a pin is tied to ground or V_{DD}, no resistors are needed.
4. If a pin is left open (no connect), no resistors are needed.

Table 4. AC Characteristics $(V_{DD} = 1.8 \pm 5\%, 2.5 \pm 10\%, \text{ or } 3.3 \text{ V} \pm 10\%, T_A = -40 \text{ to } 85 \text{ }^\circ\text{C})$

Parameter	Symbol	Test Condition	Min	Typ	Max	Units
Input Frequency	CKN_F		1	—	711	MHz
CKIN Input Pins						
Input Duty Cycle (Minimum Pulse Width)	CKN_{DC}	Whichever is smaller	40	—	60	%
			2	—	—	ns
Input Capacitance	CKN_{CIN}		—	—	3	pF
Input Rise/Fall Time	CKN_{TRF}	20–80% See Figure 2	—	—	11	ns
CKOUT Output Pins						
Output Frequency (Output not configured for CMOS or disable)	CKO_F		1	—	711	MHz
Maximum Output Frequency in CMOS Format	CKO_{FMC}		1	—	212.5	MHz
Single-ended Output Rise/Fall (20–80%)	CKO_{TRF}	CMOS Output $V_{DD} = 1.62$ Load = 5 pF	—	—	8	ns
		CMOS Output $V_{DD} = 2.97$ Load = 5 pF	—	—	2	ns
Differential Output Rise/Fall Time	CKO_{TRF}	20 to 80 %, $f_{OUT} = 622.08$	—	230	350	ps
Output Duty Cycle Differential Uncertainty	CKO_{DC}	100 Ω Load Line to Line Measured at 50% Point (not for CMOS)	—	—	± 40	ps
LVC MOS Pins						
Input Capacitance	C_{IN}		—	—	3	pF

Table 4. AC Characteristics (Continued)

($V_{DD} = 1.8 \pm 5\%$, $2.5 \pm 10\%$, or $3.3 \text{ V} \pm 10\%$, $T_A = -40$ to $85 \text{ }^\circ\text{C}$)

Parameter	Symbol	Test Condition	Min	Typ	Max	Units
LVC MOS Output Pins						
Rise/Fall Times	t_{RF}	CLOAD = 20 pf See Figure 2	—	25	—	ns
LOS _n Trigger Window	LOS _{TRIG}	From last CKIN \uparrow to LOS \uparrow	—	—	750	μs
Time to Clear LOL after LOS Cleared	t_{CLRLOL}	f_{in} unchanged and XA/XB stable. \downarrow LOS to \downarrow LOL	—	10	—	ms
PLL Performance						
Lock Time	t_{LOCKHW}	Whenever \overline{RST} , FRQTBL, RATE, BWSEL, or FRQSEL are changed, with valid CKIN to \downarrow LOL; BW = 100 Hz	—	—	1.2	sec
Closed Loop Jitter Peaking	J_{PK}		—	0.05	0.1	dB
Jitter Tolerance	J_{TOL}	BW determined by BWSEL[1:0]	5000/ BW	—	—	ns pk-pk
Minimum Reset Pulse Width	t_{RSTMIN}		1	—	—	μs
Spurious Noise	SP _{SPUR}	Max spur @ $n \times f_3$ ($n \geq 1$, $n \times f_3 < 100 \text{ MHz}$)	—	-93	-70	dBc
Phase Change due to Temperature Variation	t_{TEMP}	Max phase changes from -40 to +85 $^\circ\text{C}$	—	300	500	ps

Table 5. Performance Specifications^{1, 2, 3, 4, 5}

($V_{DD} = 1.8 \pm 5\%$, $2.5 \pm 10\%$, or $3.3 \text{ V} \pm 10\%$, $T_A = -40$ to $85 \text{ }^\circ\text{C}$)

Parameter	Symbol	Test Condition	Min	Typ	Max	Unit
Jitter Generation $f_{IN} = f_{OUT} = 622.08 \text{ MHz}$, LVPECL output format BW = 120 Hz	J_{GEN}	50 kHz–80 MHz	—	0.32	0.42	ps rms
		12 kHz–20 MHz	—	0.31	0.41	ps rms
		800 Hz–80 MHz	—	0.4	0.45	ps rms
Phase Noise $f_{IN} = f_{OUT} = 622.08 \text{ MHz}$ LVPECL output format	CKO _{PN}	1 kHz offset	—	-106	-87	dBc/Hz
		10 kHz offset	—	-121	-100	dBc/Hz
		100 kHz offset	—	-132	-104	dBc/Hz
		1 MHz offset	—	-132	-119	dBc/Hz

Notes:

- BWSEL [1:0] loop bandwidth settings provided in Table 9 on page 22.
- 114.285 MHz 3rd OT crystal used as XA/XB input.
- $V_{DD} = 2.5 \text{ V}$
- $T_A = 85 \text{ }^\circ\text{C}$
- Test condition: $f_{IN} = 622.08 \text{ MHz}$, $f_{OUT} = 622.08 \text{ MHz}$, LVPECL clock input: 1.19 Vppd with 0.5 ns rise/fall time (20-80%), LVPECL clock output.

Table 6. Thermal Characteristics(V_{DD} = 1.8 ±5%, 2.5 ±10%, or 3.3 V ±10%, T_A = -40 to 85 °C)

Parameter	Symbol	Test Condition	Min	Typ	Max	Unit
Thermal Resistance Junction to Ambient	θ_{JA}	Still Air	—	32	—	°C/W
Thermal Resistance Junction to Case	θ_{JC}		—	14	—	°C/W

Table 7. Absolute Maximum Limits

Parameter	Symbol	Value	Unit
DC Supply Voltage	V _{DD}	-0.5 to 3.8	V
LVC MOS Input Voltage	V _{DIG}	-0.3 to (V _{DD} + 0.3)	V
CKINn Voltage Level Limits	CKN _{VIN}	0 to V _{DD}	V
XA/XB Voltage Level Limits	XA _{VIN}	0 to 1.2	V
Operating Junction Temperature	T _{JCT}	-55 to 150	C
Storage Temperature Range	T _{STG}	-55 to 150	C
ESD HBM Tolerance (100 pF, 1.5 kΩ); All pins except CKIN+/CKIN-		2	kV
ESD MM Tolerance; All pins except CKIN+/CKIN-		150	V
ESD HBM Tolerance (100 pF, 1.5 kΩ); CKIN+/CKIN-		750	V
ESD MM Tolerance; CKIN+/CKIN-		100	V
Latch-Up Tolerance		JESD78 Compliant	
Note: Permanent device damage may occur if the Absolute Maximum Ratings are exceeded. Functional operation should be restricted to the conditions as specified in the operation sections of this data sheet. Exposure to absolute maximum rating conditions for extended periods of time may affect device reliability.			

2. Functional Description

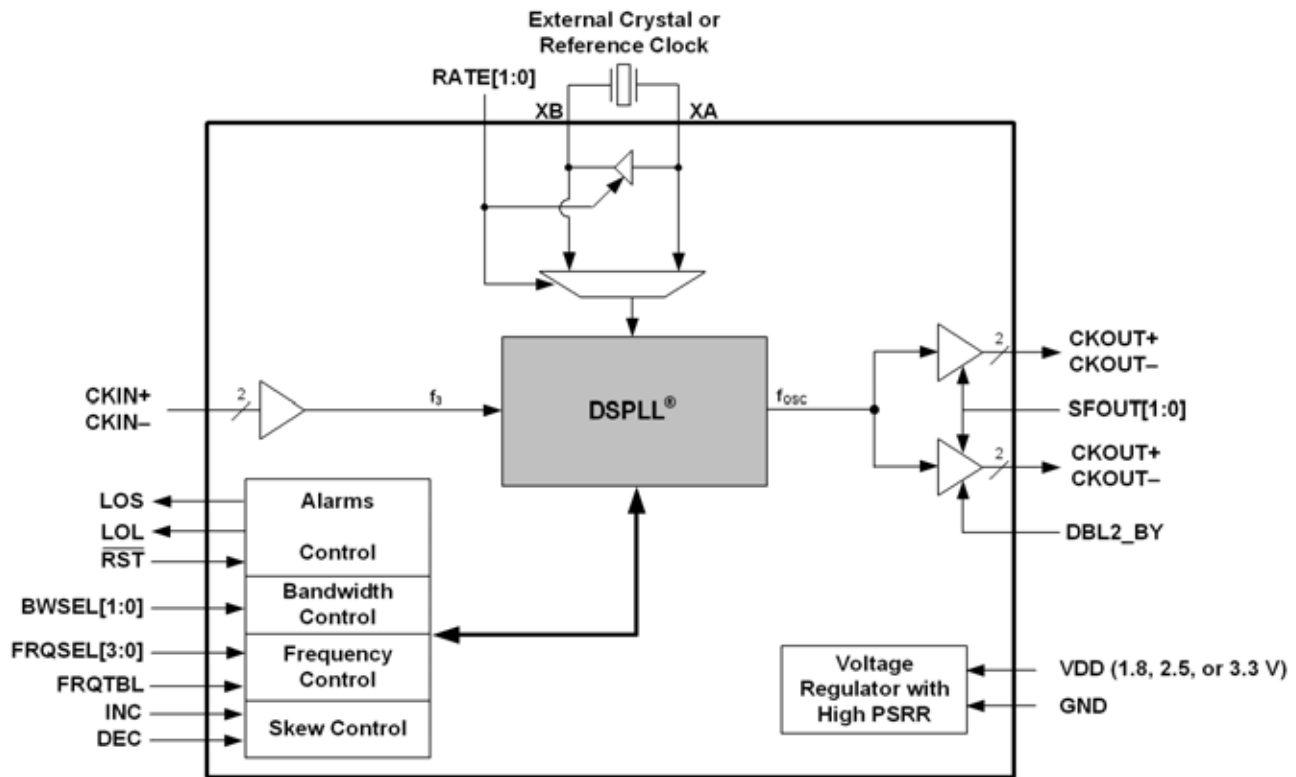

Figure 5. Detailed Block Diagram

2.1. Overview

The Si5317 is a 1:1 jitter-attenuating precision clock for applications requiring sub 1 ps jitter performance. The Si5317 accepts one clock input ranging from 1 to 711 MHz and generates two clock outputs at the same frequency ranging from 1 to 711 MHz. The Si5317 is based on Silicon Laboratories' 3rd-generation DSPLL® technology, which provides jitter attenuation on any frequency in a highly integrated PLL solution that eliminates the need for external VCXO and loop filter components. The nominal operating frequency is selectable from a look-up table. The Si5317 PLL loop bandwidth (BW) is selectable via the BWSEL[1:0] pins and supports a range from 60 Hz to 8.4 kHz.

The Si5317 monitors the input clock for loss-of-signal (LOS) and provides a LOS alarm when it detects missing pulses on the input clock. The device monitors the lock status of the DSPLL. The lock detect algorithm works by continuously monitoring the phase of the input clock in relation to the phase of the feedback clock.

The Si5317 provides a VCO freeze capability that allows the device to continue generation of a stable output clock when the selected input clock is lost. During VCO freeze, the DSPLL latches its VCO settings and uses its XA/XB clock as its frequency reference.

The Si5317 has two output clock drivers and can be configured as four single-ended or two differential outputs. The signal format of the clock output is selectable to support LVPECL, LVDS, CML, or CMOS loads. The device operates from a single 1.8, 2.5, or 3.3 V supply. The use of LVPECL requires a $VDD \geq 2.25$ V.

3. Frequency Plan Tables

For ease of use, the Si5317 is pin-controlled to enable simple device configuration of the frequency range plan and PLL loop bandwidth via a predefined look-up table. The DSPLL has been optimized for jitter performance and tunability for each frequency range and PLL loop bandwidth provided in Table 9 on page 22.

Many of the control inputs are three levels: High, Low, and Medium. High and Low are standard voltage levels determined by the supply pins: V_{DD} and Ground. If the input pin is left floating, it is driven to nominally half of V_{DD} . Effectively, this creates three logic levels for these controls. See section 6. "Power Supply Filtering" on page 33 and section 1.2. "Three-Level Input Pins (Example with External Resistors)" on page 9 for additional information.

3.1. Frequency Range Plan

The input to output clock frequency range is set by the 3-level FRQSEL[3:0] and FRQTBL pins. The CKIN and CKOUT is the same frequency range as specified in Table 8. Due to the wide tunability of the Si5317, each frequency plan provides overlap between adjacent settings. To select a frequency plan, the desired frequency should be selected as close to the defined center frequency. In certain cases where the desired frequency is exactly between two overlapping plans, either FRQTBL and FRQSEL setting can be used.

3.1.1. PLL Loop Bandwidth Plan

The Si5317's loop bandwidth ranges from 60 Hz to 8.4 kHz. For each frequency range, the corresponding loop bandwidth is provided in a simple look-up table (see Table 9 on page 22). The loop bandwidth is digitally programmable using the three-level BWSEL [1:0] input pins.

3.2. Output Skew Adjustment

The overall device skew (CKIN to CKOUTn phase delay) is adjustable via the INC and DEC input pins. A positive edge triggered pulse applied to the INC pin increases the device skew defined by Table 8, INC/DEC step size, for each given frequency plan. The identical operation on the DEC pin decreases the skew by the same amount. Using the INC and DEC pins, there is no limit to the range of skew adjustment that can be made. Following a powerup or reset, the overall device skew will revert to the reset value, although the input-to-output skew is effectively random. The rate of change for each INC/DEC operation is defined by the selected loop bandwidth, BWSEL[1:0].

Table 8. Look-up Tables for Fin = Fout Frequency Range and Loop Bandwidth Settings

Plan No	FRQTBL	FRQSEL [3:0]	Frequency Range (MHz)			BWSEL [1:0] (BW in Hz)						INC/DEC Phase Change (ns)
			Min	Center	Max	LH	ML	MM	MH	HL	HM	
0	L	LLLL	.95	1.00	1.05	—	3814	927	230	114	57	0.21
1	L	LLLM	1.00	1.05	1.10	—	3814	927	230	114	57	0.21
2	L	LLLH	1.05	1.10	1.15	—	3834	931	231	115	57	0.21
3	L	LLML	1.10	1.15	1.20	—	4052	983	244	121	60	0.21
4	L	LLMM	1.15	1.20	1.25	—	4251	1030	255	127	63	0.21
5	L	LLMH	1.20	1.25	1.30	—	4451	1078	267	133	66	0.21
6	L	LLHL	1.25	1.30	1.35	—	4652	1125	279	139	69	0.21
7	L	LLHM	1.30	1.35	1.40	—	4852	1172	290	145	72	0.21
8	L	LLHH	1.35	1.40	1.45	—	5054	1219	302	150	75	0.21
9	L	LMLL	1.40	1.45	1.50	—	5256	1267	314	156	78	0.21
10	L	LMLM	1.45	1.50	1.55	—	5256	1267	314	156	78	0.21
11	L	LMLH	1.50	1.55	1.60	—	5459	1314	325	162	81	0.21
12	L	LMML	1.55	1.60	1.65	—	5866	1409	349	174	87	0.21
13	L	LMMM	1.60	1.65	1.70	—	5866	1409	349	174	87	0.21
14	L	LMMH	1.65	1.70	1.75	—	6071	1457	360	180	89	0.21
15	L	LMHL	1.70	1.75	1.80	—	6276	1504	372	185	92	0.21
16	L	LMHM	1.75	1.80	1.85	—	6483	1552	384	191	95	0.21
17	L	LMHH	1.80	1.85	1.90	—	6688	1599	395	197	98	0.21
18	L	LHLL	1.85	1.90	1.95	—	6895	1647	407	203	101	0.21
19	L	LHLM	1.90	1.95	2.00	4696	2285	560	139	69	—	0.21
20	L	LHLH	1.95	2.00	2.10	4832	2350	575	143	71	—	0.21
21	L	LHML	2.00	2.10	2.20	4967	2415	591	147	73	—	0.21
22	L	LHMM	2.10	2.20	2.30	5239	2544	622	154	77	—	0.21
23	L	LHMH	2.20	2.30	2.40	—	4052	983	244	121	60	0.21
24	L	LHHL	2.30	2.40	2.50	—	4251	1030	255	127	63	0.21
25	L	LHHM	2.40	2.50	2.60	—	4451	1078	267	133	66	0.21
26	L	LHHH	2.50	2.60	2.70	—	4651	1125	279	139	69	0.21
27	L	MLLL	2.60	2.70	2.80	—	4852	1172	290	145	72	0.20
28	L	MLLM	2.70	2.80	2.90	—	5054	1219	302	150	75	0.21
29	L	MLLH	2.80	2.90	3.00	—	5255	1267	314	156	78	0.20
30	L	MLML	2.90	3.00	3.10	—	5458	1314	325	162	81	0.20
31	L	MLMM	3.00	3.10	3.20	—	5859	1409	349	174	87	0.20
32	L	MLMH	3.10	3.20	3.30	—	5859	1409	349	174	87	0.20

Note: For BWSEL[1:0] settings LL, LM, HH are reserved.

Table 8. Look-up Tables for Fin = Fout Frequency Range and Loop Bandwidth Settings (Continued)

Plan No	FRQTBL	FRQSEL [3:0]	Frequency Range (MHz)			BWSEL [1:0] (BW in Hz)						INC/DEC Phase Change (ns)
			Min	Center	Max	LH	ML	MM	MH	HL	HM	
33	L	MLHL	3.20	3.30	3.40	—	6071	1457	360	180	89	0.21
34	L	MLHM	3.30	3.40	3.50	—	6071	1457	360	180	89	0.21
35	L	MLHH	3.40	3.50	3.60	—	6276	1504	372	185	92	0.21
36	L	MMLL	3.50	3.60	3.70	—	6483	1552	384	191	95	0.21
37	L	MMLM	3.60	3.70	3.80	—	6895	1647	407	203	101	0.21
38	L	MMLH	3.70	3.80	3.90	—	6895	1647	407	203	101	0.21
39	L	MMML	3.80	3.90	4.00	—	4650	1125	279	139	69	0.20
40	L	MMMM	3.90	4.00	4.20	—	4786	1156	286	143	71	0.21
41	L	MMMh	4.00	4.20	4.40	—	4919	1188	294	147	73	0.21
42	L	MMHL	4.20	4.40	4.60	—	5457	1314	325	162	81	0.20
43	L	MMHM	4.40	4.60	4.80	—	5457	1314	325	162	81	0.20
44	L	MMHH	4.60	4.80	5.00	—	5730	1378	341	170	85	0.21
45	L	MHLL	4.80	5.00	5.20	—	6268	1504	372	185	92	0.20
46	L	MHLM	5.00	5.20	5.40	—	6273	1504	372	185	92	0.20
47	L	MHLH	5.20	5.40	5.60	—	6550	1568	387	193	96	0.20
48	L	MHML	5.40	5.60	5.80	—	6823	1631	403	201	100	0.20
49	L	MHMM	5.60	5.80	6.00	—	6823	1631	403	201	100	0.20
50	L	MHMh	5.80	6.00	6.20	—	6333	3064	748	185	92	0.20
51	L	MHHL	6.00	6.20	6.40	—	6571	3176	774	192	96	0.20
52	L	MHHM	6.20	6.40	6.60	—	6811	3289	801	199	99	0.20
53	L	MHHH	6.40	6.60	6.80	—	6071	1457	360	180	89	0.21
54	L	HLLL	6.60	6.80	7.00	—	6534	1567	387	193	96	0.20
55	L	HLLM	6.80	7.00	7.20	—	6534	1567	387	193	96	0.20
56	L	HLLH	7.00	7.20	7.40	—	6483	1552	384	191	95	0.21
57	L	HLML	7.20	7.40	7.60	—	6686	1599	395	197	98	0.20
58	L	HLMM	7.40	7.60	7.80	—	6891	1647	407	203	101	0.20
59	L	HLMH	7.60	7.80	8.00	—	4648	1125	279	139	69	0.20
60	L	HLHL	7.80	8.00	8.40	—	4786	1156	286	143	71	0.21
61	L	HLHM	8.00	8.40	8.80	—	4919	1188	294	147	73	0.21
62	L	HLHH	8.40	8.80	9.00	—	6599	1580	391	195	97	0.20
63	L	HMLL	8.80	9.00	9.20	—	7080	1693	418	209	104	0.19
64	L	HMLM	9.00	9.20	9.60	—	7080	1693	418	209	104	0.19
65	L	HMLH	9.20	9.60	10.00	—	5727	1377	341	170	85	0.20
66	L	HMML	9.60	10.00	10.50	—	6003	1441	356	178	88	0.21

Note: For BWSEL[1:0] settings LL, LM, HH are reserved.

Table 8. Look-up Tables for Fin = Fout Frequency Range and Loop Bandwidth Settings (Continued)

Plan No	FRQTBL	FRQSEL [3:0]	Frequency Range (MHz)			BWSEL [1:0] (BW in Hz)						INC/DEC Phase Change (ns)
			Min	Center	Max	LH	ML	MM	MH	HL	HM	
67	L	HMMM	10.00	10.50	11.00	—	6273	1504	372	185	92	0.20
68	L	HMMH	10.50	11.00	11.50	—	6992	1672	413	206	103	0.20
69	L	HMHL	11.00	11.50	12.00	—	5866	1409	349	174	87	0.21
70	L	HMHM	11.50	12.00	12.50	—	6155	1477	365	182	91	0.20
71	L	HMHH	12.00	12.50	13.00	—	6446	1545	382	190	95	0.20
72	L	HHLL	12.50	13.00	13.50	—	7034	1680	415	207	103	0.20
73	L	HHLM	13.00	13.50	14.00	—	5408	1303	323	161	80	0.20
74	L	HHLH	13.50	14.00	14.50	—	5633	1356	336	167	83	0.20
75	L	HHML	14.00	14.50	15.00	—	5861	1409	349	174	87	0.20
76	L	HHMM	14.50	15.00	15.50	—	7383	1764	436	217	108	0.19
77	L	HHMH	15.00	15.50	16.00	—	6321	1515	374	187	93	0.21
78	L	HHHL	15.50	16.00	16.50	—	6321	1515	374	187	93	0.21
79	L	HHHM	16.00	16.50	17.00	—	6774	1620	400	200	99	0.20
80	L	HHHH	16.50	17.00	17.50	—	7230	1726	426	213	106	0.20
81	M	LLLL	17.00	17.50	18.00	—	4422	1071	265	132	66	0.21
82	M	LLLM	17.50	18.00	18.50	—	7342	1756	434	216	108	0.19
83	M	LLLH	18.00	18.50	19.00	—	7342	1756	434	216	108	0.19
84	M	LLML	18.50	19.00	19.50	—	7298	1742	430	214	107	0.20
85	M	LLMM	19.00	19.50	20.00	—	4995	1206	299	149	74	0.20
86	M	LLMH	19.50	20.00	21.00	—	7518	1796	444	221	110	0.19
87	M	LLHL	20.00	21.00	22.00	—	6208	1488	368	183	91	0.21
88	M	LLHM	21.00	22.00	23.00	—	7429	1777	439	219	109	0.18
89	M	LLHH	22.00	23.00	24.00	—	6155	1477	365	182	91	0.20
90	M	LMLL	23.00	24.00	25.00	—	6155	1477	365	182	91	0.20
91	M	LMLM	24.00	25.00	26.00	—	6739	1612	399	199	99	0.20
92	M	LMLH	25.26	26.00	27.00	—	7613	1816	449	224	111	0.19
93	M	LMML	26.00	27.00	28.00	—	6817	1631	403	201	100	0.20
94	M	LMMM	27.00	28.00	29.00	—	6817	1631	403	201	100	0.20
95	M	LMMH	28.00	29.00	30.00	—	7640	1821	450	224	112	0.20
96	M	LMHL	29.00	30.00	31.00	—	4941	1194	296	147	73	0.20
97	M	LMHM	30.31	31.00	32.00	—	7658	1827	451	225	112	0.19
98	M	LMHH	31.00	32.00	33.00	—	7658	1827	451	225	112	0.19
99	M	LHLL	32.00	33.00	34.00	—	6774	1620	400	200	99	0.20
100	M	LHLM	33.00	34.00	35.00	—	6774	1620	400	200	99	0.20

Note: For BWSEL[1:0] settings LL, LM, HH are reserved.

Table 8. Look-up Tables for Fin = Fout Frequency Range and Loop Bandwidth Settings (Continued)

Plan No	FRQTBL	FRQSEL [3:0]	Frequency Range (MHz)			BWSEL [1:0] (BW in Hz)						INC/DEC Phase Change (ns)
			Min	Center	Max	LH	ML	MM	MH	HL	HM	
101	M	LHLH	34.00	35.00	36.00	—	7692	1832	452	225	112	0.20
102	M	LHML	35.00	36.00	37.00	—	7680	1833	453	226	113	0.19
103	M	LHMM	36.00	37.00	38.00	—	7539	1803	446	222	111	0.18
104	M	LHMH	37.00	38.00	39.00	—	7658	1827	451	225	112	0.19
105	M	LHHL	38.00	39.00	40.00	—	7607	1818	449	224	112	0.18
106	M	LHHM	39.00	40.00	42.00	—	7607	1818	449	224	112	0.18
107	M	LHHH	40.00	42.00	44.00	—	5709	1373	340	169	84	0.21
108	M	MLLL	43.30	44.00	46.00	—	7653	1828	452	225	112	0.18
109	M	MLLM	44.00	46.00	48.00	—	7653	1828	452	225	112	0.18
110	M	MLLH	46.00	48.00	50.00	—	6155	1477	365	182	91	0.20
111	M	MLML	48.00	50.00	52.00	—	7630	1823	450	225	112	0.18
112	M	MLMM	50.52	52.00	54.00	—	7692	1832	452	225	112	0.20
113	M	MLMH	52.00	54.00	56.00	—	7880	1882	465	232	116	0.18
114	M	MLHL	54.00	56.00	58.00	—	6169	1481	366	183	91	0.20
115	M	MLHM	56.00	58.00	60.00	—	7664	1826	451	225	112	0.20
116	M	MLHH	58.00	60.00	60.00	—	7664	1826	451	225	112	0.20
117	M	MMLL	60.00	62.00	64.00	—	7882	1882	465	232	116	0.18
118	M	MMLM	62.00	64.00	66.00	—	7890	1883	465	232	116	0.18
119	M	MMLH	64.00	66.00	68.00	—	7878	1882	465	232	116	0.18
120	M	MMML	66.00	68.00	70.00	—	7878	1882	465	232	116	0.18
121	M	MMMM	68.00	70.00	70.88	—	6228	1494	369	184	92	0.20
122	M	MMMh	70.00	72.00	74.00	—	7888	1883	465	232	116	0.18
123	M	MMHL	72.00	74.00	76.00	—	7889	1883	465	232	116	0.18
124	M	MMHM	75.78	76.00	78.00	—	7917	1884	465	232	116	0.20
125	M	MMHH	76.00	78.00	80.00	—	7895	1883	465	232	116	0.19
126	M	MHLL	78.00	80.00	84.00	—	7895	1883	465	232	116	0.19
127	M	MHLM	80.00	84.00	88.00	—	6010	1445	357	178	89	0.20
128	M	MHLH	84.00	88.00	88.59	—	6010	1445	357	178	89	0.20
129	M	MHML	88.00	90.00	92.00	—	6329	1518	375	187	93	0.20
130	M	MHMM	90.00	92.00	96.00	—	7878	1882	465	232	116	0.18
131	M	MHMH	92.00	96.00	100.00	—	7795	1864	461	230	114	0.18
132	M	MHHL	96.00	100.00	105.00	—	7795	1864	461	230	114	0.18
133	M	MHHM	101.04	105.00	110.00	—	7903	1884	465	232	116	0.19
134	M	MHHH	105.00	110.00	115.00	—	7812	1866	461	230	115	0.18

Note: For BWSEL[1:0] settings LL, LM, HH are reserved.

Table 8. Look-up Tables for Fin = Fout Frequency Range and Loop Bandwidth Settings (Continued)

Plan No	FRQTBL	FRQSEL [3:0]	Frequency Range (MHz)			BWSEL [1:0] (BW in Hz)						INC/DEC Phase Change (ns)
			Min	Center	Max	LH	ML	MM	MH	HL	HM	
135	M	HLLL	110.00	115.00	118.13	—	6329	1518	375	187	93	0.20
136	M	HLLM	115.00	120.00	125.00	—	7820	1867	461	230	115	0.18
137	M	HLLH	120.00	125.00	130.00	—	7812	1868	462	230	115	0.18
138	M	HLML	125.00	130.00	135.00	—	7878	1882	465	232	116	0.18
139	M	HLMM	130.00	135.00	140.00	—	6873	1648	408	203	101	0.19
140	M	HLMH	135.00	140.00	145.00	—	7851	1871	462	230	115	0.19
141	M	HLHL	140.00	145.00	150.00	—	7826	1870	462	230	115	0.18
142	M	HLHM	145.00	150.00	155.00	—	7240	1735	429	214	107	0.18
143	M	HLHH	151.56	155.00	160.00	—	7853	1872	462	230	115	0.19
144	M	HMLL	155.00	160.00	165.00	—	7890	1883	465	232	116	0.18
145	M	HMLM	160.00	165.00	170.00	—	7831	1871	462	231	115	0.18
146	M	HMLH	165.00	170.00	175.00	—	7831	1871	462	231	115	0.18
147	M	HMML	170.00	175.00	177.19	—	6912	1654	409	204	102	0.20
148	M	HMMM	175.00	180.00	185.00	—	7140	1710	423	211	105	0.19
149	M	HMMH	180.00	185.00	190.00	—	7846	1873	463	231	115	0.18
150	M	HMHL	185.00	190.00	195.00	—	7878	1882	465	232	116	0.18
151	M	HMHM	190.00	195.00	200.00	—	7878	1882	465	232	116	0.18
152	M	HMHM	195.00	200.00	202.50	—	6993	1673	414	206	103	0.19
153	M	HHLL	202.08	210.00	220.00	—	7903	1884	465	232	116	0.19
154	M	HHLM	210.00	220.00	230.00	—	7069	1689	417	208	104	0.20
155	M	HHLH	220.45	230.00	240.00	—	7903	1884	465	232	116	0.19
156	M	HHML	230.00	240.00	250.00	—	7507	1793	443	221	110	0.19
157	M	HHMM	242.50	250.00	260.00	—	7910	1884	465	232	116	0.19
158	M	HHMH	250.00	260.00	270.00	—	7878	1882	465	232	116	0.18
159	M	HHHL	260.00	270.00	280.00	—	7429	1776	439	219	109	0.19
160	M	HHHM	270.00	280.00	290.00	—	7908	1884	465	232	116	0.19
161	M	HHHH	280.00	290.00	300.00	—	7879	1882	465	232	116	0.18
162	H	LLLL	290.00	300.00	310.00	—	7571	1811	448	223	111	0.18
163	H	LLLM	303.13	310.00	320.00	—	7903	1884	465	232	116	0.19
164	H	LLLH	310.00	320.00	330.00	—	7890	1883	465	232	116	0.18
165	H	LLML	320.00	330.00	340.00	—	7878	1882	465	232	116	0.18
166	H	LLMM	330.00	340.00	350.00	—	7878	1882	465	232	116	0.18
167	H	LLMH	340.00	350.00	354.38	—	7344	1757	434	217	108	0.18

Note: For BWSEL[1:0] settings LL, LM, HH are reserved.

Table 8. Look-up Tables for Fin = Fout Frequency Range and Loop Bandwidth Settings (Continued)

Plan No	FRQTBL	FRQSEL [3:0]	Frequency Range (MHz)			BWSEL [1:0] (BW in Hz)						INC/DEC Phase Change (ns)
			Min	Center	Max	LH	ML	MM	MH	HL	HM	
168	H	LLHL	350.00	360.00	370.00	—	7900	1883	465	232	116	0.19
169	H	LLHM	360.00	370.00	380.00	—	7889	1883	465	232	116	0.18
170	H	LLHH	370.00	380.00	390.00	—	7878	1882	465	232	116	0.18
171	H	LMLL	380.00	390.00	400.00	—	7878	1882	465	232	116	0.18
172	H	LMLM	390.00	400.00	405.00	—	7755	1854	458	228	114	0.18
173	H	LMLH	404.17	420.00	440.00	—	7903	1884	465	232	116	0.19
174	H	LMML	420.00	440.00	460.00	—	7848	1874	463	231	115	0.18
175	H	LMMM	440.91	460.00	480.00	—	7903	1884	465	232	116	0.19
176	H	LMMH	460.00	480.00	500.00	—	7507	1793	443	221	110	0.19
177	H	LMHL	485.00	500.00	520.00	—	7910	1884	465	232	116	0.19
178	H	LMHM	500.00	520.00	540.00	—	7878	1882	465	232	116	0.18
179	H	LMHH	520.00	540.00	560.00	—	7704	1842	455	227	113	0.18
180	H	LHLL	540.00	560.00	580.00	—	7908	1884	465	232	116	0.19
181	H	LHLM	560.00	580.00	600.00	—	7879	1882	465	232	116	0.18
182	H	LHLH	580.00	600.00	620.00	—	7571	1811	448	223	111	0.18
183	H	LHML	606.25	620.00	640.00	—	7903	1884	465	232	116	0.19
184	H	LHMM	620.00	640.00	660.00	—	7890	1883	465	232	116	0.18
185	H	LHMH	640.00	660.00	680.00	—	7878	1882	465	232	116	0.18
186	H	LHHL	660.00	680.00	700.00	—	7878	1882	465	232	116	0.18
187	H	LHHM	680.00	700.00	704.00	—	7831	1871	462	231	115	0.18
188	H	LHHH	700.00	7.05	711.00	—	7908	1880	464	231	115	0.20

Note: For BWSEL[1:0] settings LL, LM, HH are reserved.

3.3. PLL Self-Calibration

An internal self-calibration (ICAL) is performed before operation to optimize loop parameters and jitter performance. While the self-calibration is being performed, the DSPLL is being internally controlled by the self-calibration state machine. The LOL alarm will be active during ICAL. The self-calibration time t_{LOCKHW} is given in Table 4, "AC Characteristics".

Any of the following events will trigger a self-calibration:

- Power-on-reset (POR)
- Release of the external reset pin \overline{RST} (transition of \overline{RST} from 0 to 1)
- Change in FRQSEL, FRQTBL, BWSEL, or RATE[1:0] pins
- Internal DSPLL registers out-of-range, indicating the need to relock the DSPLL

In any of the above cases, an ICAL will be initiated if a valid input clock exists with no input alarm. The external crystal or reference clock must also be present for the self-calibration to begin. If no valid input clock is present, the self-calibration state machine will wait until it appears, at which time the calibration will start.

After a successful ICAL has been performed with a valid input clock, no subsequent self-calibrations are performed unless one of the above conditions are met. If the input clock is lost following self-calibration, the device enters VCO freeze mode. When the input clock returns, the device relocks to the input clock without performing a self-calibration.

3.3.1. Input Clock Stability during Internal Self-Calibration

An exit from reset must occur when the selected CKIN clock is stable in frequency with a frequency value that is within the device operating range.

3.3.2. Self-Calibration caused by Changes in Input Frequency

If the selected CKIN frequency varies by 500 ppm or more within the frequency range defined by FRQSEL and FRQTBL since the last calibration, the device may initiate a self-calibration.

3.3.3. Device Reset

Upon powerup, the device internally executes a power-on-reset (POR) which resets the internal device logic. The pin \overline{RST} can also be used to initiate a reset. The device stays in this state until a valid CKINn is present, when it then performs a PLL self-calibration (refer to section 3.3. "PLL Self-Calibration").

3.3.4. Recommended Reset Guidelines

Follow the recommended RESET guidelines in Table 9 that describe when reset should be applied to a device.

Table 9. Si5317 Pins and Reset

Pin #	Si5317 Pin Name	Must Reset after Changing
2	FRQTBL	Yes
11	RATE0	Yes
15	RATE1	Yes
22	BWSEL0	Yes
23	BWSEL1	Yes
24	FRQSEL0	Yes
25	FRQSEL1	Yes
26	FRQSEL2	Yes
27	FRQSEL3	Yes

3.4. Alarms

Summary alarms are available to indicate the overall status of the input signals. Alarm outputs stay high until all the alarm conditions for that alarm output are cleared.

3.4.1. Loss-of-Signal

The device has loss-of-signal circuitry that continuously monitors CKIN for missing pulses.

An LOS condition on CKIN causes the LOS alarm to become active. Once a LOS alarm is asserted, it remains asserted until the input clock is validated over a designated time period. The time to clear LOS after a valid input clock appears is listed in Table 4, “AC Characteristics”. If another error condition on the same input clock is detected during the validation time, then the alarm remains asserted and the validation time starts over.

3.4.1.1. LOS Algorithm

The LOS circuitry divides down each input clock to produce an 8 kHz to 2 MHz signal. The LOS circuitry oversamples this divided down input clock using a 40 MHz clock to search for extended periods of time without input clock transitions. If the LOS monitor detects twice the normal number of samples without a clock edge, a LOS alarm is declared. Table 4, “AC Characteristics” gives the minimum and maximum amount of time for the LOS monitor to trigger.

3.4.1.2. Lock Detect

The PLL lock detection algorithm indicates the lock status on the LOL output pin. The algorithm works by continuously monitoring the phase of the input clock in relation to the phase of the feedback clock. If the time between two consecutive phase cycle slips is greater than the retrigger time, the PLL is in lock. The LOL output has a guaranteed minimum pulse width as shown in Table 4, “AC Characteristics”. The LOL pin is also held in the active state during an internal PLL calibration. The retrigger time is automatically set based on the PLL closed loop bandwidth (see Table 10).

Table 10. Lock Detect Retrigger Time

PLL Bandwidth Setting (BW)	Retrigger Time (ms)
60–120 Hz	53
120–240 Hz	26.5
240–480 Hz	13.3
480–960 Hz	6.6
960–1920 Hz	3.3
1920–3840 Hz	1.66
3840–7680 Hz	0.833

3.5. VCO Freeze

The Si5317 device features a VCO freeze mode whereby the DSPLL is locked to a frequency value.

If an LOS condition exists on the selected input clock, the device freezes the VCO. In this mode, the device provides a stable output frequency until the input clock returns and is validated. When the device enters VCO freeze, the internal oscillator is initially held to its last frequency value.

3.5.1. Recovery from VCO Freeze

When the input clock signal returns, the device transitions from VCO freeze to the selected input clock.

3.6. PLL Bypass Mode

The Si5317 supports a PLL bypass mode in which the selected input clock is fed directly to both enabled output buffers, bypassing the DSPLL. Internally, the bypass path is implemented with high-speed signaling; however, this path is not a low jitter path and will result in significantly higher jitter on CKOUT. In PLL bypass mode, the input and output clocks will be at the same frequency. PLL bypass mode is useful as a debug tool. The DSBL2_BY pin is used to select the PLL Bypass Mode according to Table 11. Bypass mode is not supported for CMOS clock outputs.

Table 11. DSBL2/BYPASS Pin Settings

DSBL2/BYPASS	Function
L	CKOUT2 Enabled
M	CKOUT2 Disabled
H	PLL Bypass Mode w/ CKOUT2 Enabled

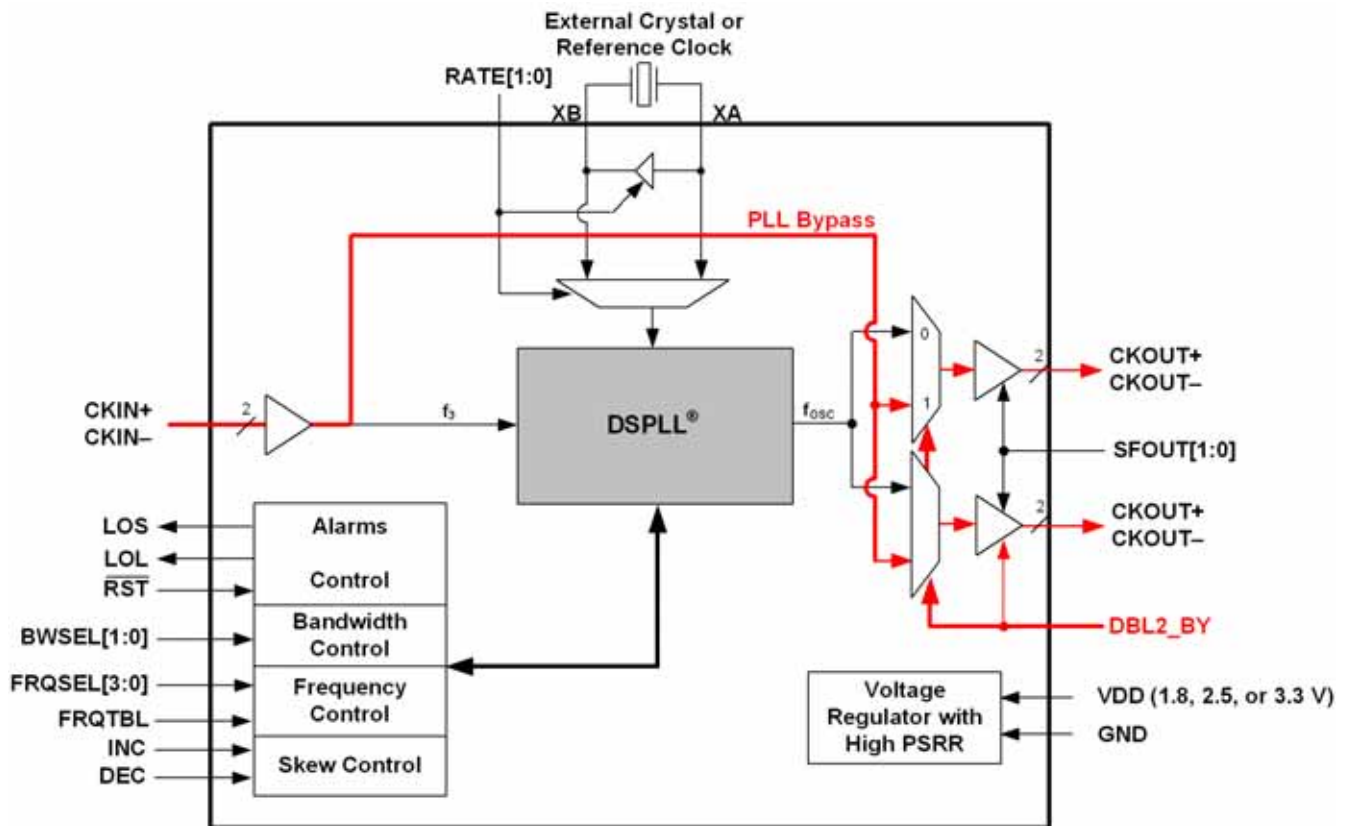

Figure 6. Bypass Signal

4. High-Speed I/O

4.1. Input Clock Buffer

The Si5317 provides differential inputs for the CKIN clock input. This input is internally biased to a common mode voltage (see Table 2, “DC Characteristics”) and can be driven by either a single-ended or differential source. No additional external bias is required. Figure 7 through Figure 10 show typical interface circuits for LVPECL, CML, LVDS, or CMOS input clocks. Note that the jitter generation improves for higher levels on CKINn within the limits in Table 4, “AC Characteristics”.

AC coupling the input clocks is recommended because it removes any issue with common mode input voltages. DC coupling is acceptable if the device driving the Si5317 meets all of the input clock requirements, including the input common mode range and the peak-to-peak swing specifications. Figure 7 and Figure 8 shows various examples of different input termination arrangements. Unused inputs can be left unconnected.

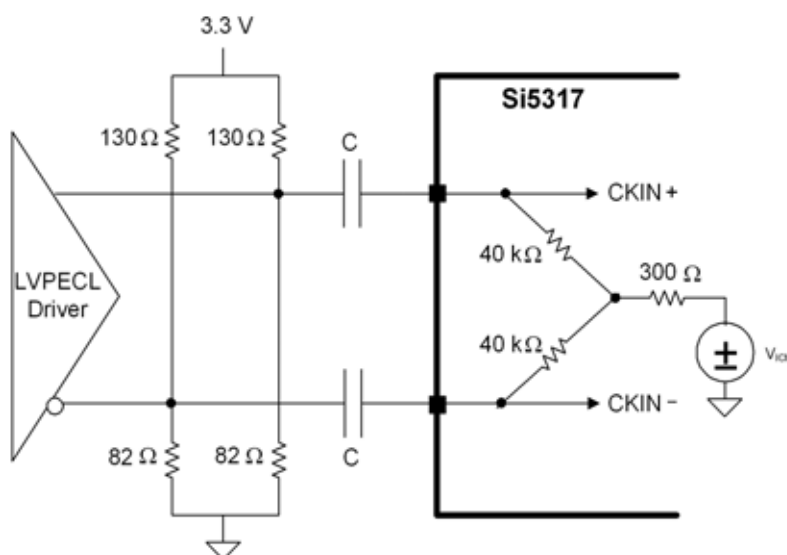

Figure 7. Differential LVPECL Termination

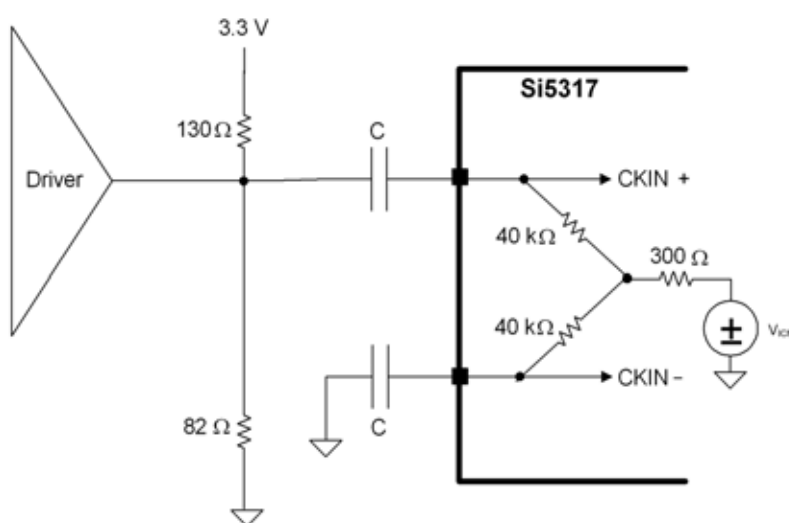

Figure 8. Single-ended LVPECL Termination