



Chipsmall Limited consists of a professional team with an average of over 10 year of expertise in the distribution of electronic components. Based in Hongkong, we have already established firm and mutual-benefit business relationships with customers from,Europe,America and south Asia,supplying obsolete and hard-to-find components to meet their specific needs.

With the principle of “Quality Parts,Customers Priority,Honest Operation,and Considerate Service”,our business mainly focus on the distribution of electronic components. Line cards we deal with include Microchip,ALPS,ROHM,Xilinx,Pulse,ON,Everlight and Freescale. Main products comprise IC,Modules,Potentiometer,IC Socket,Relay,Connector.Our parts cover such applications as commercial,industrial, and automotives areas.

We are looking forward to setting up business relationship with you and hope to provide you with the best service and solution. Let us make a better world for our industry!



Contact us

Tel: +86-755-8981 8866 Fax: +86-755-8427 6832

Email & Skype: info@chipsmall.com Web: www.chipsmall.com

Address: A1208, Overseas Decoration Building, #122 Zhenhua RD., Futian, Shenzhen, China



DUAL 1:5 LOW-JITTER, ANY-FORMAT BUFFER/LEVEL TRANSLATOR (<1.25 GHz)

Features

- 2 independent banks of 5x differential outputs
- Ultra-low additive jitter: 45 fs rms
- Wide frequency range: dc to 1.25 GHz
- Any-format input with pin selectable output formats: LVPECL, Low Power LVPECL, LVDS, CML, HCSL, LVCMOS
- Asynchronous output enable
- Low output-output skew: <70 ps
- Output clock division: /1, /2, /4 (dc to 725 MHz for /2 and /4)
- Independent V_{DD} and V_{DDO} : 1.8/2.5/3.3 V
- Excellent power supply noise rejection (PSRR)
- Small size: 44-QFN (7 mm x 7 mm)
- RoHS compliant, Pb-free
- Industrial temperature range: -40 to +85 °C

Applications

- High-speed clock distribution
- Ethernet switch/router
- Optical Transport Network (OTN)
- SONET/SDH
- PCI Express Gen 1/2/3
- Storage
- Telecom
- Industrial
- Servers
- Backplane clock distribution

Description

The Si53313 is an ultra low jitter dual 1:5 differential buffer with pin-selectable output clock signal format and divider selection. The Si53313 utilizes Silicon Laboratories' advanced CMOS technology to fanout clocks from dc to 1.25 GHz with guaranteed low additive jitter, low skew, and low propagation delay variability. The Si53313 features minimal cross-talk and provides superior supply noise rejection, simplifying low jitter clock distribution in noisy environments. Independent core and output bank supply pins provide integrated level translation without the need for external circuitry.

Functional Block Diagram

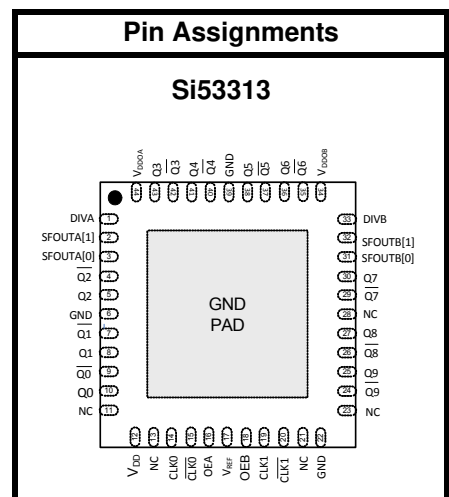
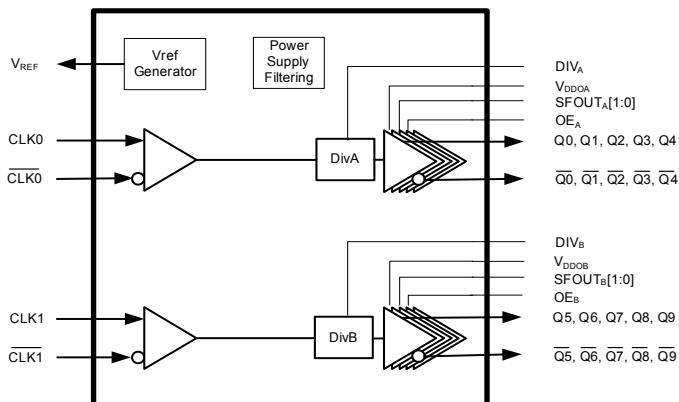

Patents pending

Si53313

TABLE OF CONTENTS

<u>Section</u>	<u>Page</u>
1. Electrical Specifications	3
2. Functional Description	11
2.1. Universal, Any-Format Input	11
2.2. Input Bias Resistors	13
2.3. Voltage Reference (VREF)	13
2.4. Universal, Any-Format Output Buffer	14
2.5. Flexible Output Divider	15
2.6. Output Enable Logic	15
2.7. Power Supply (VDD and VDDOX)	15
2.8. Output Clock Termination Options	16
2.9. AC Timing Waveforms	19
2.10. Typical Phase Noise Performance	20
2.11. Input Mux Noise Isolation	23
2.12. Power Supply Noise Rejection	23
3. Pin Description: 44-Pin QFN	24
4. Ordering Guide	27
5. Package Outline	28
5.1. 7x7 mm 44-QFN Package Diagram	28
6. PCB Land Pattern	30
6.1. 7x7 mm 44-QFN Package Land Pattern	30
7. Top Marking	31
7.1. Si53313 Top Marking	31
7.2. Top Marking Explanation	31
Document Change List	32
Contact Information	33

1. Electrical Specifications

Table 1. Recommended Operating Conditions

Parameter	Symbol	Test Condition	Min	Typ	Max	Unit
Ambient Operating Temperature	T_A		-40	—	85	°C
Supply Voltage Range*	V_{DD}	LVDS, CML	1.71	1.8	1.89	V
			2.38	2.5	2.63	V
			2.97	3.3	3.63	V
		LVPECL, low power LVPECL, LVC MOS	2.38	2.5	2.63	V
			2.97	3.3	3.63	V
		HCSL	2.97	3.3	3.63	V
Output Buffer Supply Voltage*	V_{DDOX}	LVDS, CML, LVC MOS	1.71	1.8	1.89	V
			2.38	2.5	2.63	V
			2.97	3.3	3.63	V
		LVPECL, low power LVPECL	2.38	2.5	2.63	V
			2.97	3.3	3.63	V
		HCSL	2.97	3.3	3.63	V

***Note:** Core supply V_{DD} and output buffer supplies V_{DDOX} are independent. LVC MOS clock input is not supported for $V_{DD} = 1.8V$ but is supported for LVC MOS clock output for $V_{DDOX} = 1.8V$. LVC MOS outputs at 1.5V and 1.2V can be supported via a simple resistor divider network. See “2.8.1. LVC MOS Output Termination To Support 1.5 V and 1.2 V”

Table 2. Input Clock Specifications

($V_{DD}=1.8 V \pm 5\%$, $2.5 V \pm 5\%$, or $3.3 V \pm 10\%$, $T_A=-40$ to 85 °C)

Parameter	Symbol	Test Condition	Min	Typ	Max	Unit
Differential Input Common Mode Voltage	V_{CM}	$V_{DD} = 2.5 V \pm 5\%$, $3.3 V \pm 10\%$	0.05	—	—	V
Differential Input Swing (peak-to-peak)	V_{IN}		0.2	—	2.2	V
LVC MOS Input High Voltage	V_{IH}	$V_{DD} = 2.5 V \pm 5\%$, $3.3 V \pm 10\%$	$V_{DD} \times 0.7$	—	—	V
LVC MOS Input Low Voltage	V_{IL}	$V_{DD} = 2.5 V \pm 5\%$, $3.3 V \pm 10\%$	—	—	$V_{DD} \times 0.3$	V
Input Capacitance	C_{IN}	CLK0 and CLK1 pins with respect to GND	—	5	—	pF

Table 3. DC Common Characteristics

($V_{DD} = 1.8\text{ V} \pm 5\%$, $2.5\text{ V} \pm 5\%$, or $3.3\text{ V} \pm 10\%$, $T_A = -40\text{ to }85\text{ }^\circ\text{C}$)

Parameter	Symbol	Test Condition	Min	Typ	Max	Unit
Supply Current	I_{DD}		—	65	100	mA
Output Buffer Supply Current (Per Clock Output) @100 MHz	I_{DDOX}	LVPECL (3.3 V)	—	35	—	mA
		Low Power LVPECL (3.3 V)	—	35	—	mA
		LVDS (3.3 V)	—	20	—	mA
		CML (3.3 V)	—	30	—	mA
		HCSL, 100 MHz, 2 pF load (3.3 V)	—	35	—	mA
		CMOS (1.8 V, SFOUT = Open/0), per output, $C_L = 5\text{ pF}$, 200 MHz	—	5	—	mA
		CMOS (2.5 V, SFOUT = Open/0), per output, $C_L = 5\text{ pF}$, 200 MHz	—	8	—	mA
		CMOS (3.3 V, SFOUT = 0/1), per output, $C_L = 5\text{ pF}$, 200 MHz	—	15	—	mA
Voltage Reference	V_{REF}	V_{REF} pin ($-500\text{ }\mu\text{A} < I_{REF} < 500\text{ }\mu\text{A}$)	—	$V_{DD}/2$	—	V
Input High Voltage	V_{IH}	SFOUTx, DIVx, CLK_SEL, OEx	$0.8 \times V_{DD}$	—	—	V
Input Mid Voltage	V_{IM}	SFOUTx, DIVx 3-level input pins	$0.45 \times V_{DD}$	$0.5 \times V_{DD}$	$0.55 \times V_{DD}$	V
Input Low Voltage	V_{IL}	SFOUTx, DIVx, CLK_SEL, OEx	—	—	$0.2 \times V_{DD}$	V
Internal Pull-down Resistor	R_{DOWN}	CLK_SEL, DIVx, SFOUTx,	—	25	—	k Ω
Internal Pull-up Resistor	R_{UP}	OEx, DIVx, SFOUTx	—	25	—	k Ω

Table 4. Output Characteristics (LVPECL)

($V_{DDOX} = 2.5\text{ V} \pm 5\%$, or $3.3\text{ V} \pm 10\%$, $T_A = -40\text{ to }85\text{ }^\circ\text{C}$)

Parameter	Symbol	Test Condition	Min	Typ	Max	Unit
Output DC Common Mode Voltage	V_{COM}		$V_{DDOX} - 1.595$	—	$V_{DDOX} - 1.245$	V
Single-Ended Output Swing	V_{SE}		0.40	0.80	1.050	V

***Note:** Unused outputs can be left floating. Do not short unused outputs to ground.

Table 5. Output Characteristics (Low Power LVPECL) $(V_{DDOX} = 2.5\text{ V} \pm 5\%$, or $3.3\text{ V} \pm 10\%$, $T_A = -40$ to $85\text{ }^\circ\text{C}$)

Parameter	Symbol	Test Condition	Min	Typ	Max	Unit
Output DC Common Mode Voltage	V_{COM}	$R_L = 100\ \Omega$ across Q_n and $\overline{Q_n}$	$V_{DDOX} - 1.895$		$V_{DDOX} - 1.275$	V
Single-Ended Output Swing	V_{SE}	$R_L = 100\ \Omega$ across Q_n and $\overline{Q_n}$	0.20	0.60	0.85	V

Table 6. Output Characteristics—CML $(V_{DDOX} = 1.8\text{ V} \pm 5\%$, $2.5\text{ V} \pm 5\%$, or $3.3\text{ V} \pm 10\%$, $T_A = -40$ to $85\text{ }^\circ\text{C}$)

Parameter	Symbol	Test Condition	Min	Typ	Max	Unit
Single-Ended Output Swing	V_{SE}	Terminated as shown in Figure 9 (CML termination).	200	400	550	mV

Table 7. Output Characteristics—LVDS $(V_{DDOX} = 1.8\text{ V} \pm 5\%$, $2.5\text{ V} \pm 5\%$, or $3.3\text{ V} \pm 10\%$, $T_A = -40$ to $85\text{ }^\circ\text{C}$)

Parameter	Symbol	Test Condition	Min	Typ	Max	Unit
Single-Ended Output Swing	V_{SE}	$R_L = 100\ \Omega$ across Q_N and $\overline{Q_N}$	200	—	490	mV
Output Common Mode Voltage ($V_{DDO} = 2.5\text{ V}$ or 3.3 V)	V_{COM1}	$V_{DDOX} = 2.38$ to 2.63 V , 2.97 to 3.63 V , $R_L = 100\ \Omega$ across Q_N and $\overline{Q_N}$	1.10	1.25	1.35	V
Output Common Mode Voltage ($V_{DDO} = 1.8\text{ V}$)	V_{COM2}	$V_{DDOX} = 1.71$ to 1.89 V , $R_L = 100\ \Omega$ across Q_N and $\overline{Q_N}$	0.85	0.97	1.25	V

Table 8. Output Characteristics—LVCMOS $(V_{DDOX} = 1.8\text{ V} \pm 5\%$, $2.5\text{ V} \pm 5\%$, or $3.3\text{ V} \pm 10\%$, $T_A = -40$ to $85\text{ }^\circ\text{C}$)

Parameter	Symbol	Test Condition	Min	Typ	Max	Unit
Output Voltage High	V_{OH}		$0.75 \times V_{DDOX}$	—	—	V
Output Voltage Low	V_{OL}		—	—	$0.25 \times V_{DDOX}$	V

***Note:** I_{OH} and I_{OL} per the Output Signal Format Table for specific V_{DDOX} and SFOUTx settings.

Table 9. Output Characteristics—HCSL

($V_{DDOX} = 3.3\text{ V} \pm 10\%$, $T_A = -40\text{ to }85\text{ }^\circ\text{C}$)

Parameter	Symbol	Test Condition	Min	Typ	Max	Unit
Output Voltage High	V_{OH}	$R_L = 50\ \Omega$ to GND	550	700	900	mV
Output Voltage Low	V_{OL}	$R_L = 50\ \Omega$ to GND	-150	0	150	mV
Single-Ended Output Swing	V_{SE}	$R_L = 50\ \Omega$ to GND	450	700	850	mV
Crossing Voltage	V_C	$R_L = 50\ \Omega$ to GND	250	350	550	mV

Table 10. AC Characteristics

($V_{DD} = V_{DDOX} = 1.8\text{ V} \pm 5\%$, $2.5\text{ V} \pm 5\%$, or $3.3\text{ V} \pm 10\%$, $T_A = -40\text{ to }85\text{ }^\circ\text{C}$)

Parameter	Symbol	Test Condition	Min	Typ	Max	Unit
Frequency ¹	F	LVPECL, low power LVPECL, LVDS, CML, HCSL	dc	—	1.25	GHz
		LVC MOS	dc	—	200	MHz
Duty Cycle ²	D_C	200 MHz, 20/80% $T_R/T_F < 10\%$ of period (LVC MOS) (12 mA drive)	40	50	60	%
		20/80% $T_R/T_F < 10\%$ of period (Differential)	47	50	53	%
Minimum Input Clock Slew Rate ³	SR	Required to meet prop delay and additive jitter specifications (20–80%)	0.75	—	—	V/ns
Output Rise/Fall Time	T_R/T_F	LVDS, 20/80%	—	—	325	ps
		LVPECL, 20/80%	—	—	350	ps
		HCSL ⁴ , 20/80%	—	—	280	ps
		CML, 20/80%	—	—	350	ps
		Low-Power LVPECL, 20/80%	—	—	325	ps
		LVC MOS 200 MHz, 20/80%, 2 pF load	—	—	750	ps

Notes:

1. Slew rate should be $\geq 30\text{ mV/ns}$.
2. 50% input duty cycle.
3. When using the on-chip clock divider, a minimum input clock slew rate of 30 mV/ns is required.
4. HCSL measurements were made with receiver termination. See Figure 9 on page 17.
5. Output to Output skew specified for outputs with an identical configuration.
6. Defined as skew between any output on different devices operating at the same supply voltage, temperature, and equal load condition. Using the same type of inputs on each device, the outputs are measured at the differential cross points.
7. Measured for 156.25 MHz carrier frequency. Sine-wave noise added to V_{DDOX} ($3.3\text{ V} = 100\text{ mV}_{PP}$) and noise spur amplitude measured. See “AN491: Power Supply Rejection for Low-Jitter Clocks” for further details.

Table 10. AC Characteristics (Continued) $(V_{DD} = V_{DDOX} = 1.8\text{ V} \pm 5\%, 2.5\text{ V} \pm 5\%, \text{ or } 3.3\text{ V} \pm 10\%, T_A = -40\text{ to } 85\text{ }^\circ\text{C})$

Parameter	Symbol	Test Condition	Min	Typ	Max	Unit
Minimum Input Pulse Width	T_W		360	—	—	ps
Propagation Delay	T_{PLH}, T_{PHL}	LVCMOS (12mA drive with no load)	1250	2000	2750	ps
		LVPECL	600	800	1000	ps
		LVDS	600	800	1000	ps
Output Enable Time	T_{EN}	F = 1 MHz	—	2500	—	ns
		F = 100 MHz	—	30	—	ns
		F = 725 MHz	—	5	—	ns
Output Disable Time	T_{DIS}	F = 1 MHz	—	2000	—	ns
		F = 100 MHz	—	30	—	ns
		F = 725 MHz	—	5	—	ns
Output to Output Skew ⁵	T_{SK}	LVCMOS (12 mA drive to no load)	—	50	120	ps
		LVPECL	—	35	70	ps
		LVDS	—	35	70	ps
Part to Part Skew ⁶	T_{PS}	Differential	—	—	150	ps
Power Supply Noise Rejection ⁷	PSRR	10 kHz sinusoidal noise	—	-63	—	dBc
		100 kHz sinusoidal noise	—	-62	—	dBc
		500 kHz sinusoidal noise	—	-58	—	dBc
		1 MHz sinusoidal noise	—	-55	—	dBc

Notes:

1. Slew rate should be ≥ 30 mV/ns.
2. 50% input duty cycle.
3. When using the on-chip clock divider, a minimum input clock slew rate of 30 mV/ns is required.
4. HCSL measurements were made with receiver termination. See Figure 9 on page 17.
5. Output to Output skew specified for outputs with an identical configuration.
6. Defined as skew between any output on different devices operating at the same supply voltage, temperature, and equal load condition. Using the same type of inputs on each device, the outputs are measured at the differential cross points.
7. Measured for 156.25 MHz carrier frequency. Sine-wave noise added to V_{DDOX} ($3.3\text{ V} = 100\text{ mV}_{PP}$) and noise spur amplitude measured. See "AN491: Power Supply Rejection for Low-Jitter Clocks" for further details.

Table 11. Additive Jitter, Differential Clock Input

V _{DD}	Input ^{1,2}				Output	Additive Jitter (fs rms, 12 kHz to 20 MHz) ³	
	Freq (MHz)	Clock Format	Amplitude V _{IN} (Single-Ended, Peak-to-Peak)	Differential 20%-80% Slew Rate (V/ns)		Clock Format	Typ
3.3	725	Differential	0.15	0.637	LVPECL	45	65
3.3	725	Differential	0.15	0.637	LVDS	50	65
3.3	156.25	Differential	0.5	0.458	LVPECL	160	185
3.3	156.25	Differential	0.5	0.458	LVDS	150	200
2.5	725	Differential	0.15	0.637	LVPECL	45	65
2.5	725	Differential	0.15	0.637	LVDS	50	65
2.5	156.25	Differential	0.5	0.458	LVPECL	145	185
2.5	156.25	Differential	0.5	0.458	LVDS	145	195

Notes:

1. For best additive jitter results, use the fastest slew rate possible. See “AN766: Understanding and Optimizing Clock Buffer’s Additive Jitter Performance” for more information.
2. AC-coupled differential inputs.
3. Measured differentially using a balun at the phase noise analyzer input. See Figure 2.

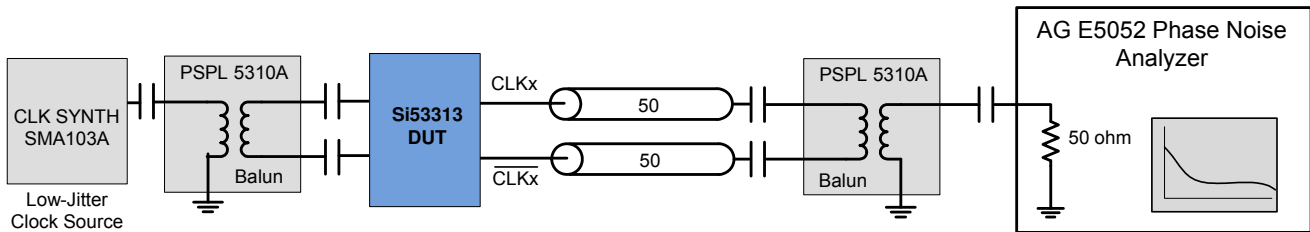

Figure 1. Differential Measurement Method Using a Balun

Important: See AN925 for additional information on the dependence of measured additive jitter on the input source jitter.

Table 12. Additive Jitter, Single-Ended Clock Input

V _{DD}	Input ^{1,2}				Output	Additive Jitter (fs rms, 12 kHz to 20 MHz) ³	
	Freq (MHz)	Clock Format	Amplitude V _{IN} (single-ended, peak to peak)	SE 20%-80% Slew Rate (V/ns)		Clock Format	Typ
3.3	200	Single-ended	1.70	1	LVC MOS ⁴	120	160
3.3	156.25	Single-ended	2.18	1	LVPECL	160	185
3.3	156.25	Single-ended	2.18	1	LVDS	150	200
3.3	156.25	Single-ended	2.18	1	LVC MOS ⁴	130	180
2.5	200	Single-ended	1.70	1	LVC MOS ⁵	120	160
2.5	156.25	Single-ended	2.18	1	LVPECL	145	185
2.5	156.25	Single-ended	2.18	1	LVDS	145	195
2.5	156.25	Single-ended	2.18	1	LVC MOS ⁵	140	180

Notes:

1. For best additive jitter results, use the fastest slew rate possible. See “AN766: Understanding and Optimizing Clock Buffer’s Additive Jitter Performance” for more information.
2. DC-coupled single-ended inputs.
3. Measured differentially using a balun at the phase noise analyzer input. See Figure 2.
4. Drive Strength: 12 mA, 3.3 V (SFOUT = 11). LVC MOS jitter is measured single-ended.
5. Drive Strength: 9 mA, 2.5 V (SFOUT = 11). LVC MOS jitter is measured single-ended.

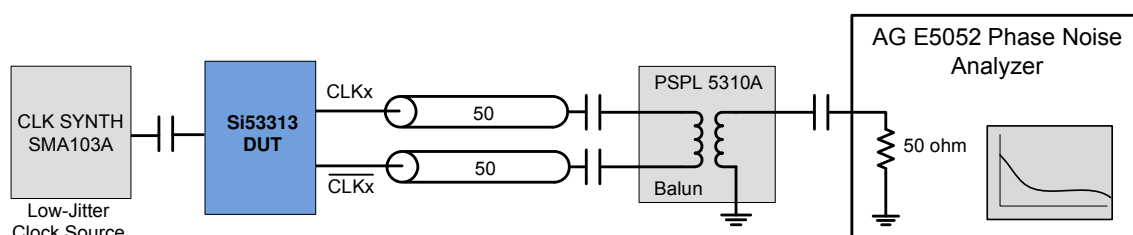

Figure 2. Single-Ended Measurement Method Using a Balun

Important: See AN925 for additional information on the dependence of measured additive jitter on the input source jitter.

Table 13. Thermal Conditions

Parameter	Symbol	Test Condition	Value	Unit
Thermal Resistance, Junction to Ambient	θ_{JA}	Still air	49.6	°C/W
Thermal Resistance, Junction to Case	θ_{JC}	Still air	32.3	°C/W

Table 14. Absolute Maximum Ratings

Parameter	Symbol	Test Condition	Min	Typ	Max	Unit
Storage Temperature	T_S		-55	—	150	°C
Supply Voltage	V_{DD}		-0.5	—	3.8	V
Input Voltage	V_{IN}		-0.5	—	$V_{DD} + 0.3$	V
Output Voltage	V_{OUT}		—	—	$V_{DD} + 0.3$	V
ESD Sensitivity	HBM	HBM, 100 pF, 1.5 k Ω	—	—	2000	V
ESD Sensitivity	CDM		—	—	500	V
Peak Soldering Reflow Temperature	T_{PEAK}	Pb-Free; Solder reflow profile per JEDEC J-STD-020	—	—	260	°C
Maximum Junction Temperature	T_J		—	—	125	°C

Note: Stresses beyond those listed in this table may cause permanent damage to the device. Functional operation specification compliance is not implied at these conditions. Exposure to maximum rating conditions for extended periods may affect device reliability.

2. Functional Description

The Si53313 is a low-jitter, low-skew dual 1:5 differential output buffer with an independent input for each bank. The device has an any-format input that accepts most common differential or LVCMOS input signals. Each output bank features control pins to select signal format, output enable, output divider setting and LVCMOS drive strength.

2.1. Universal, Any-Format Input

The Si53313 has a universal input stage that enables simple interfacing to a wide variety of clock formats, including LVPECL, LVCMOS, LVDS, HCSL, and CML. Tables 15 and 16 summarize the various input ac- and dc-coupling options supported by the device. Figures 3, 4, and 5 show the recommended input clock termination options.

Table 15. LVPECL, LVCMOS, and LVDS

	LVPECL		LVCMOS		LVDS	
	AC-Couple	DC-Couple	AC-Couple	DC-Couple	AC-Couple	DC-Couple
1.8 V	N/A	N/A	No	No	Yes	No
2.5/3.3 V	Yes	Yes	No	Yes	Yes	Yes

Table 16. HCSL and CML

	HCSL		CML	
	AC-Couple	DC-Couple	AC-Couple	DC-Couple
1.8 V	No	No	Yes	No
2.5/3.3 V	Yes	Yes	Yes	No

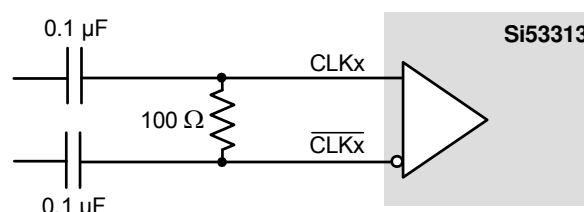

Figure 3. Differential LVPECL, LVDS, CML AC-Coupled Input Termination

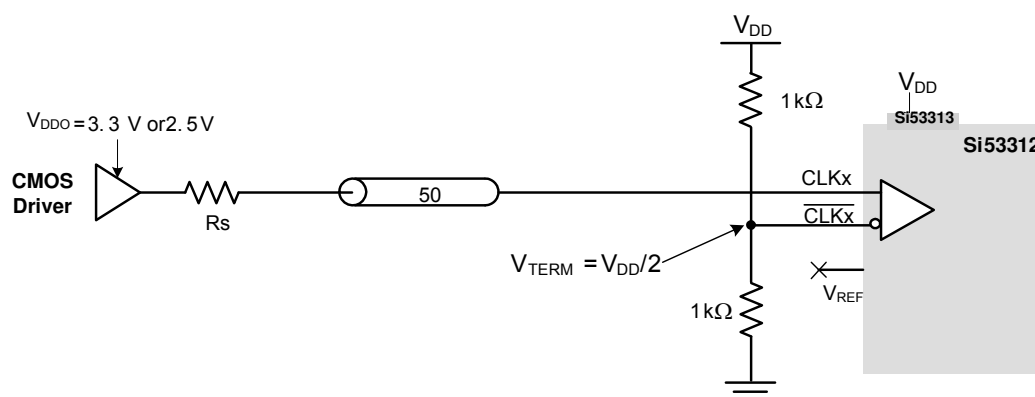
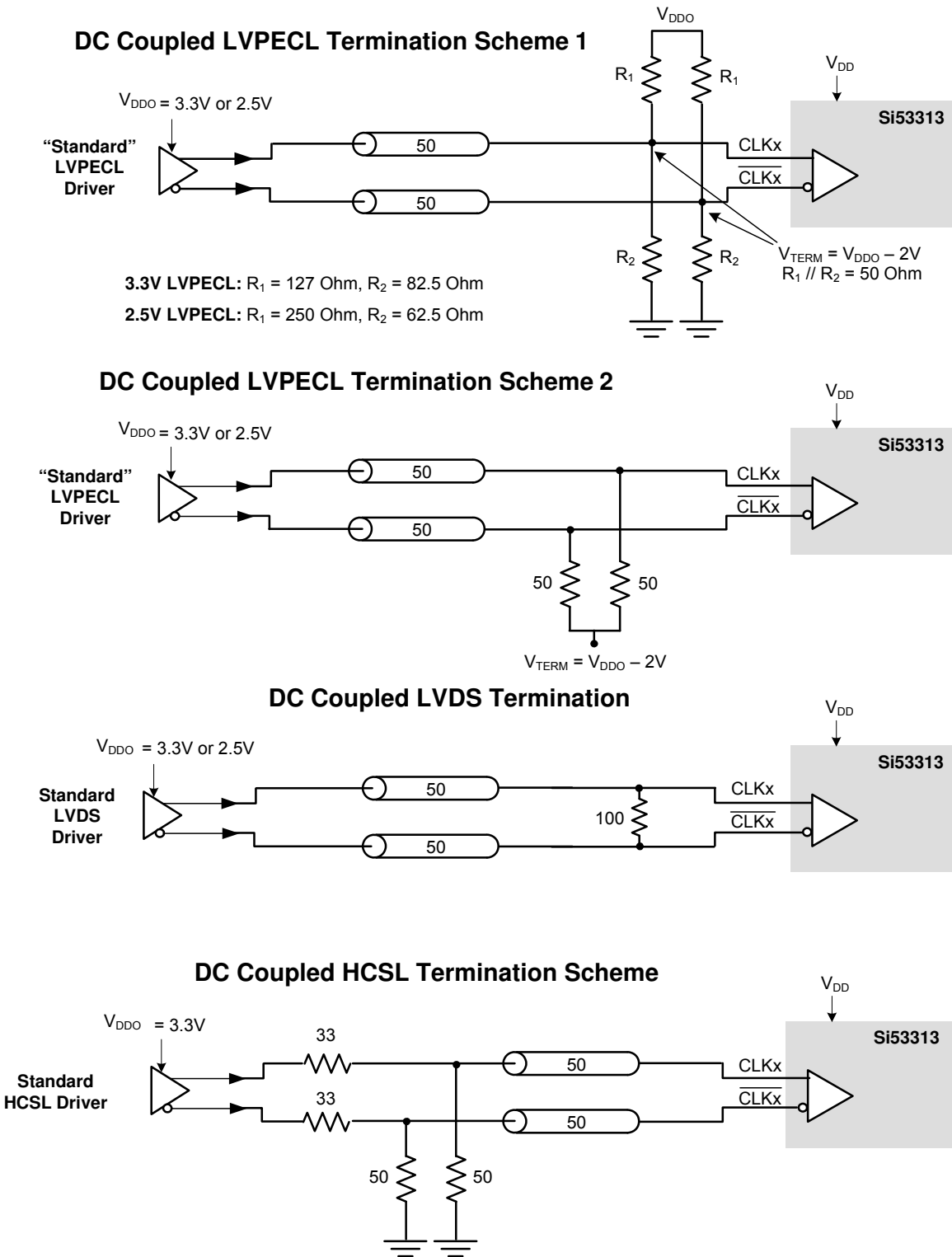

Figure 4. LVCMOS DC-Coupled Input Termination



Note: 33 Ohm series termination is optional depending on the location of the receiver.

Figure 5. Differential DC-Coupled Input Terminations

2.2. Input Bias Resistors

Internal bias resistors ensure a differential output low condition in the event that the clock inputs are not connected. The non-inverting input is biased with a 18.75 kΩ pulldown to GND and a 75 kΩ pullup to V_{DD}. The inverting input is biased with a 75 kΩ pullup to V_{DD}.

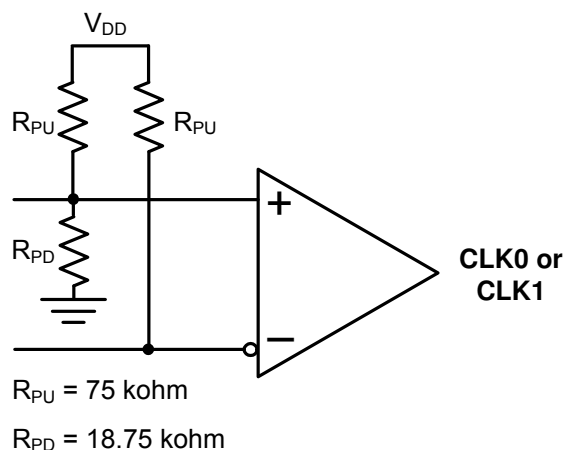

Figure 6. Input Bias Resistors

2.3. Voltage Reference (V_{REF})

The V_{REF} pin can be used to bias the input receiver, as shown in Figure 7 when a single-ended input clock (such as LVCMOS) is used. Note that V_{REF} = V_{DD}/2 and should be compatible with the VCM rating of the single-ended input clock driving the CLK0 or CLK1 inputs. To optimize jitter and duty cycle performance, use the circuit in Figure 4. V_{REF} pin should be left floating when differential clocks are used.

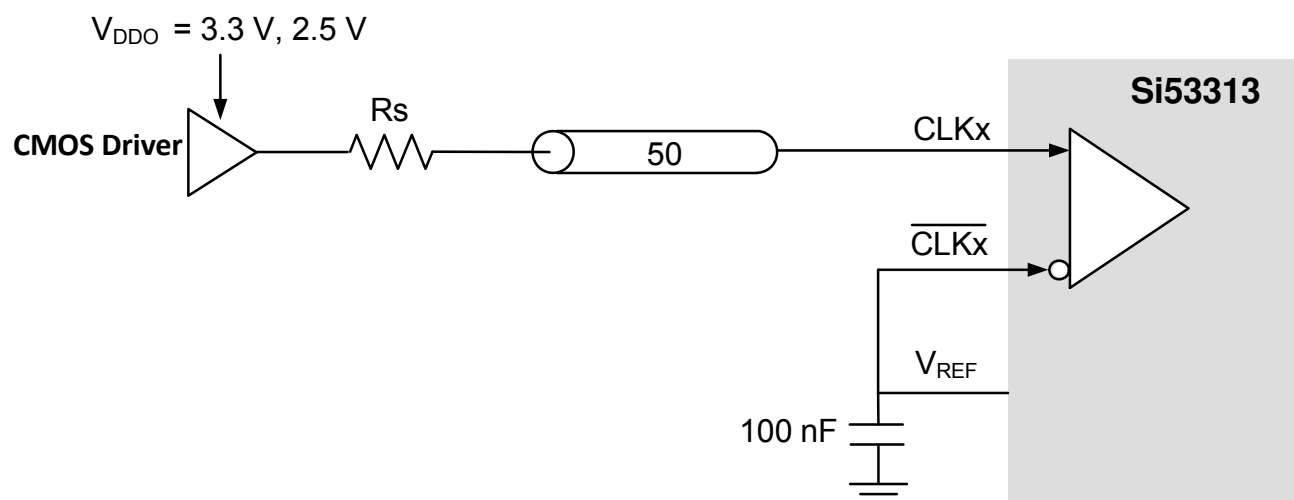

Figure 7. Using Voltage Reference with Single-Ended Input Clock

2.4. Universal, Any-Format Output Buffer

The highly flexible output drivers support a wide range of clock signal formats, including LVPECL, low power LVPECL, LVDS, CML, HCSL, and LVCMOS. SFOUTx[1] and SFOUTx[0] are 3-level inputs that can be pinstrapped to select the Bank A and Bank B clock signal formats independently. This feature enables the device to be used for format/level translation in addition to clock distribution, minimizing the number of unique buffer part numbers required in a typical application and simplifying design reuse. For EMI reduction applications, four LVCMOS drive strength options are available for each V_{DDO} setting.

Table 17. Output Signal Format Selection

SFOUTx[1]	SFOUTx[0]	$V_{DDOX} = 3.3\text{ V}$	$V_{DDOX} = 2.5\text{ V}$	$V_{DDOX} = 1.8\text{ V}$
Open*	Open*	LVPECL	LVPECL	N/A
0	0	LVDS	LVDS	LVDS
0	1	LVCMOS, 24 mA drive	LVCMOS, 18 mA drive	LVCMOS, 12 mA drive
1	0	LVCMOS, 18 mA drive	LVCMOS, 12 mA drive	LVCMOS, 9 mA drive
1	1	LVCMOS, 12 mA drive	LVCMOS, 9 mA drive	LVCMOS, 6 mA drive
Open*	0	LVCMOS, 6 mA drive	LVCMOS, 4 mA drive	LVCMOS, 2 mA drive
Open*	1	LVPECL Low power	LVPECL Low power	N/A
0	Open*	CML	CML	CML
1	Open*	HCSL	N/A	N/A

***Note:** SFOUTx[1:0] are 3-level input pins. Tie low for “0” setting. Tie high for “1” setting. When left open, the pin is internally biased to $V_{DD}/2$.

2.5. Flexible Output Divider

The Si53313 provides optional clock division in addition to clock distribution. The divider setting for each bank of output clocks is selected via 3-level control pins as shown in the table below. Leaving the DIVx pins open will force a divider value of 1, which is the default mode of operation. Note that when using the on-chip clock divider, a minimum input clock slew rate of 30 mV/ns is required.

Table 18. Divider Selection

DIVx*	Divider Value	Frequency Range
Open	÷1 (default)	dc to 1.25 GHz
0	÷2	dc to 725 MHz
1	÷4	dc to 725 MHz

*Note: DIVx are 3-level input pins. Tie low for “0” setting. Tie high for “1” setting. When left open, the pin is internally biased to $V_{DD}/2$.

2.6. Output Enable Logic

Each 1:5 output has an independent clock input (CLK0/CLK1) and an output enable pin. Table 19 summarizes the input and output clock based upon the state of the input clock and the OE pin.

Table 19. Input Clock and Output Enable Logic

CLK	OE ¹	Q ²
L	H	L
H	H	H
X	L	L ³

Notes:

- Output enable active high.
- On the next negative transition of CLK0 or CLK1.
- Single-ended: Q = low, \overline{Q} = low
Differential: Q = low, \overline{Q} = high.

2.7. Power Supply (V_{DD} and V_{DDOX})

The device includes separate core (V_{DD}) and output driver supplies (V_{DDOX}). This feature allows the core to operate at a lower voltage than V_{DDO} , reducing current consumption in mixed supply applications. The core V_{DD} supports 3.3 V, 2.5 V, or 1.8 V. Each output bank has its own V_{DDOX} supply, supporting 3.3 V, 2.5 V, or 1.8 V as defined in Table 1 on page 3.

2.8. Output Clock Termination Options

The recommended output clock termination options are shown below. Unused output clocks should be left floating.

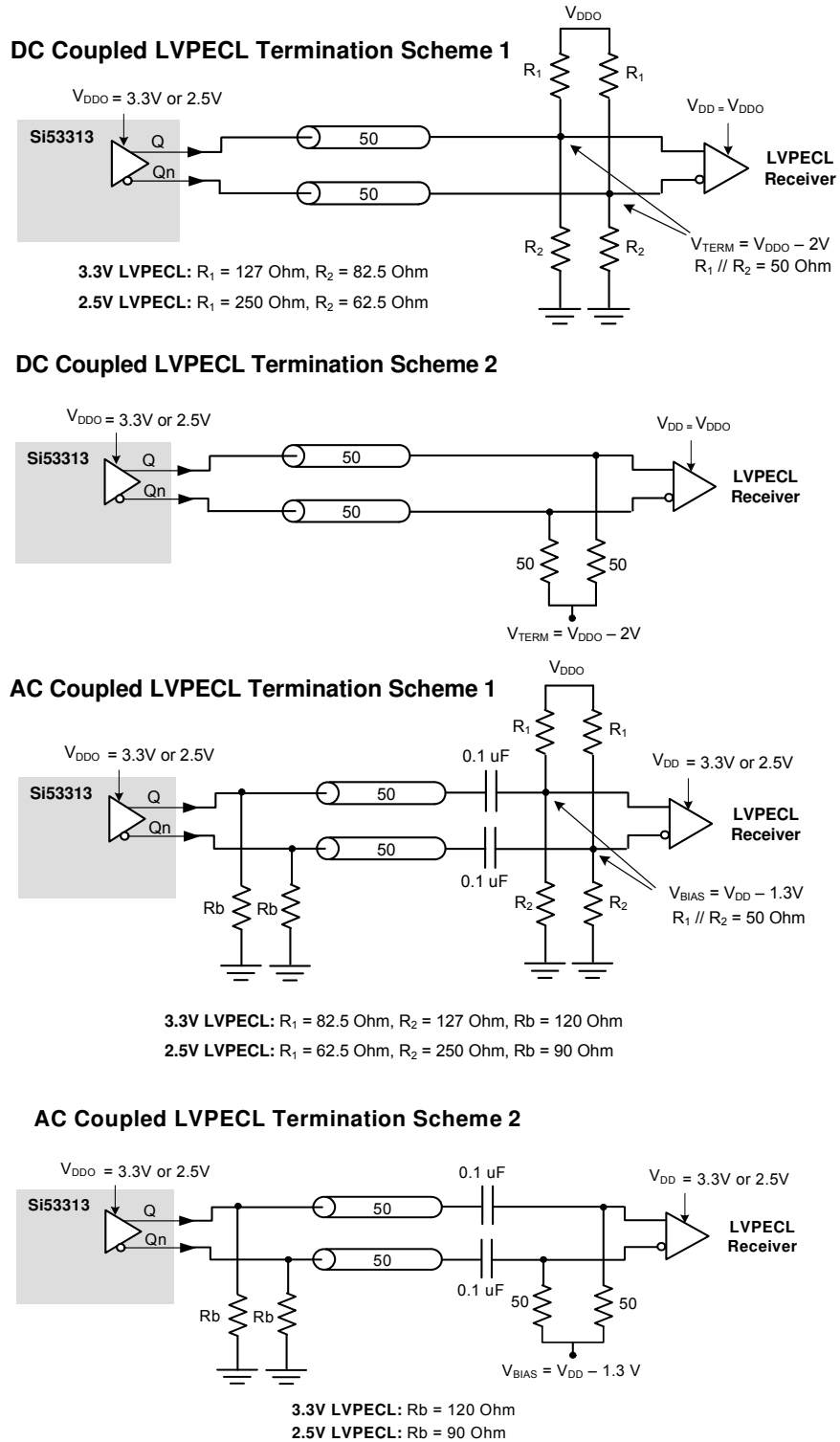

Figure 8. LVPECL Output Termination

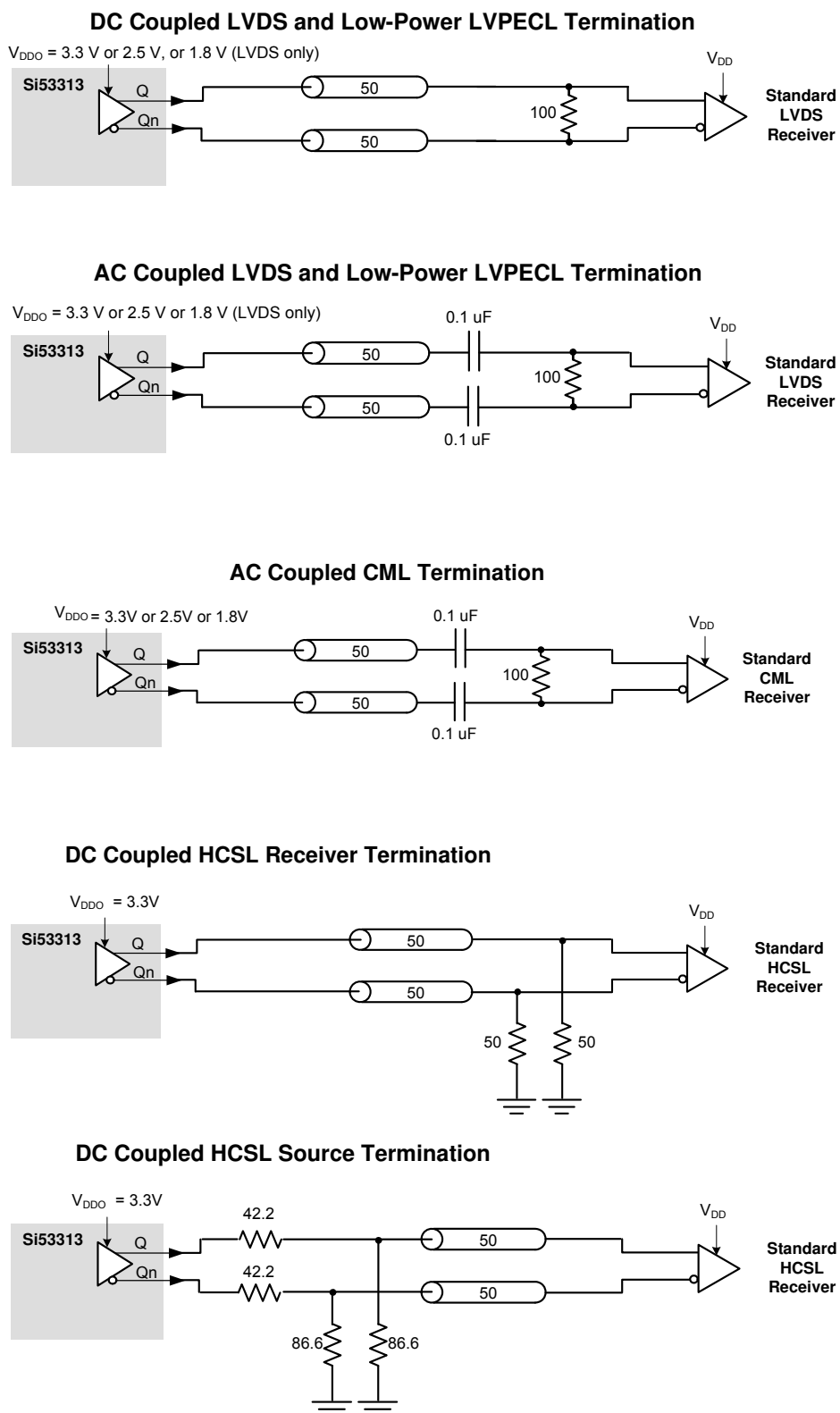

Figure 9. LVDS, CML, HCSL, and Low-Power LVPECL Output Termination

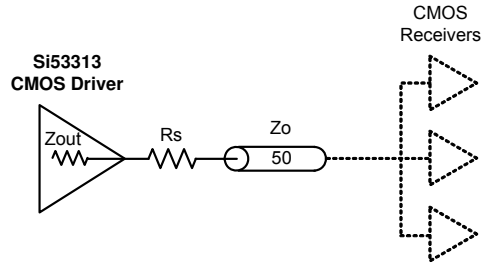

Figure 10. LVC MOS Output Termination

Table 20. Recommended LVC MOS R_S Series Termination

SFOUTx[1]	SFOUTx[0]	R_S (ohms)		
		3.3 V	2.5 V	1.8 V
0	1	33	33	33
1	0	33	33	33
1	1	33	33	0
Open	0	0	0	0

2.8.1. LVC MOS Output Termination To Support 1.5 V and 1.2 V

LVC MOS clock outputs are natively supported at 1.8 V, 2.5 V, and 3.3 V. However, 1.2 V and 1.5 V LVC MOS clock outputs can be supported via a simple resistor divider network that will translate the buffer’s 1.8 V output to a lower voltage as shown in Figure 11.

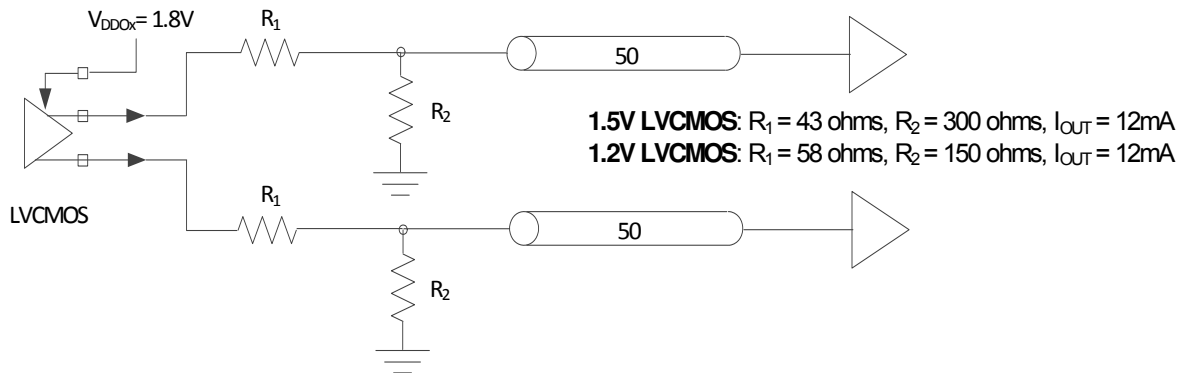

Figure 11. 1.5V and 1.2V LVC MOS Low-Voltage Output Termination

2.9. AC Timing Waveforms

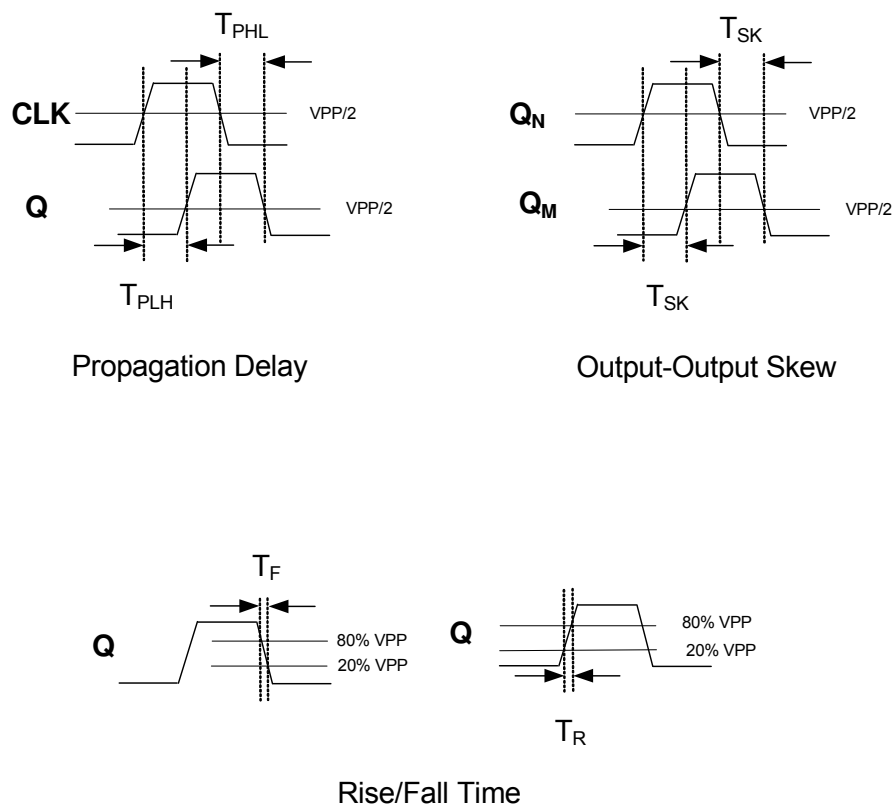

Figure 12. AC Waveforms

2.10. Typical Phase Noise Performance

Each of the following three figures shows three phase noise plots superimposed on the same diagram.

Source Jitter: Reference clock phase noise.

Total Jitter (SE): Combined source and clock buffer phase noise measured as a single-ended output to the phase noise analyzer and integrated from 12 kHz to 20 MHz.

Total Jitter (Diff): Combined source and clock buffer phase noise measured as a differential output to the phase noise analyzer and integrated from 12 kHz to 20 MHz. The differential measurement as shown in each figure is made using a balun. See Figure 2 on page 9.

Note: To calculate the total RMS phase jitter when adding a buffer to your clock tree, use the root-sum-square (RSS).

The total jitter is a measure of the source plus the buffer's additive phase jitter. The additive jitter (rms) of the buffer can then be calculated (via root-sum-square addition).

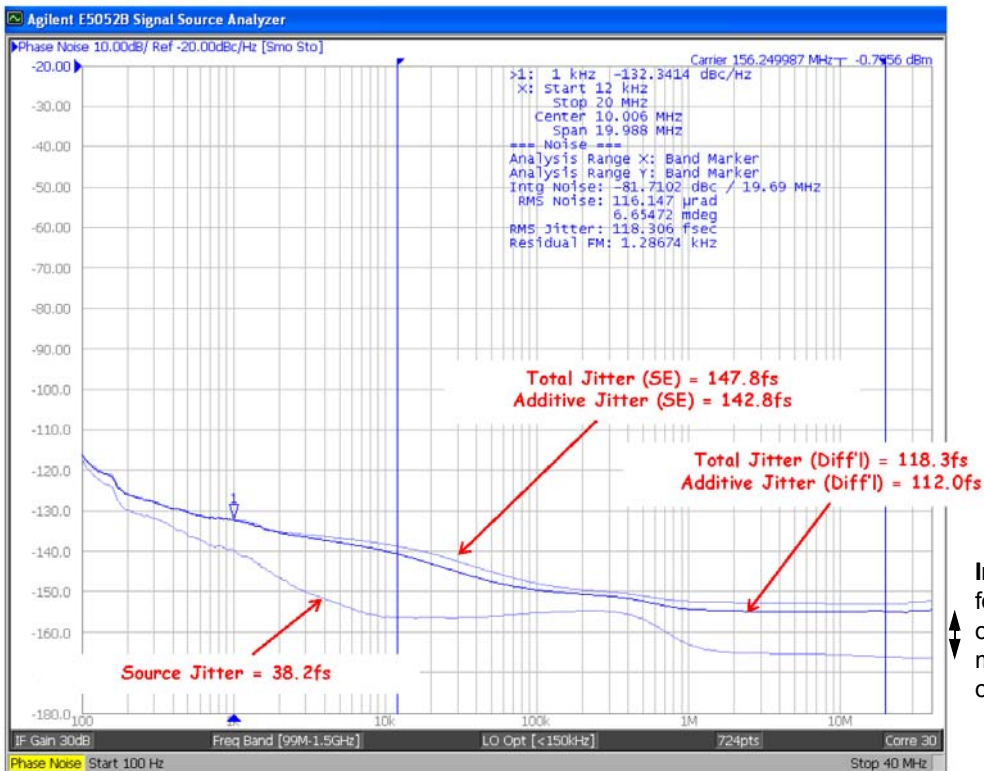

Important: See AN925 for additional information on the dependence of measured additive jitter on the input source jitter.

Figure 13. Source Jitter (156.25 MHz)

Table 21. Source Jitter (156.25 MHz)

Frequency (MHz)	Diff'l Input Slew Rate (V/ns)	Source Jitter (fs)	Total Jitter (SE) (fs)	Additive Jitter (SE) (fs)	Total Jitter (Diff'l) (fs)	Additive Jitter (Diff'l) (fs)
156.25	1.0	38.2	147.8	142.8	118.3	112.0

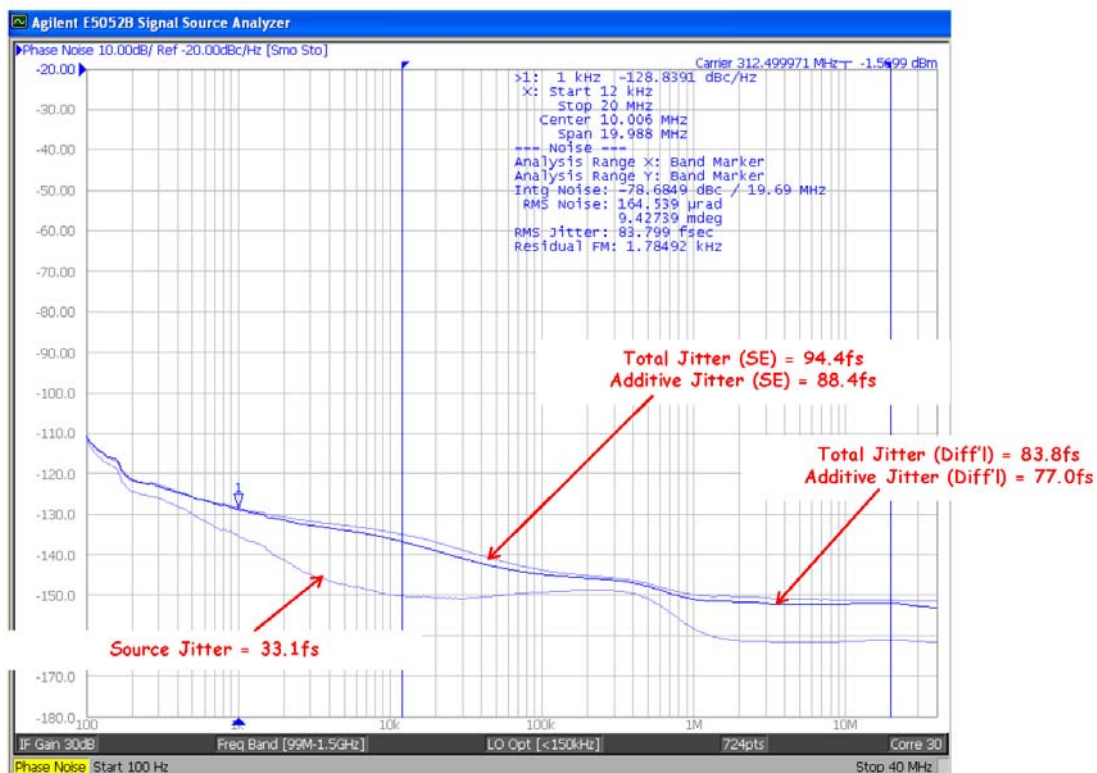

Figure 14. Single-ended Total Jitter (312.5 MHz)

Table 22. Single-ended Total Jitter (312.5 MHz)

Frequency (MHz)	Diff'l Input Slew Rate (V/ns)	Source Jitter (fs)	Total Jitter (SE) (fs)	Additive Jitter (SE) (fs)	Total Jitter (Diff'l) (fs)	Additive Jitter (Diff'l) (fs)
312.5	1.0	33.10	94.39	88.39	83.80	76.99

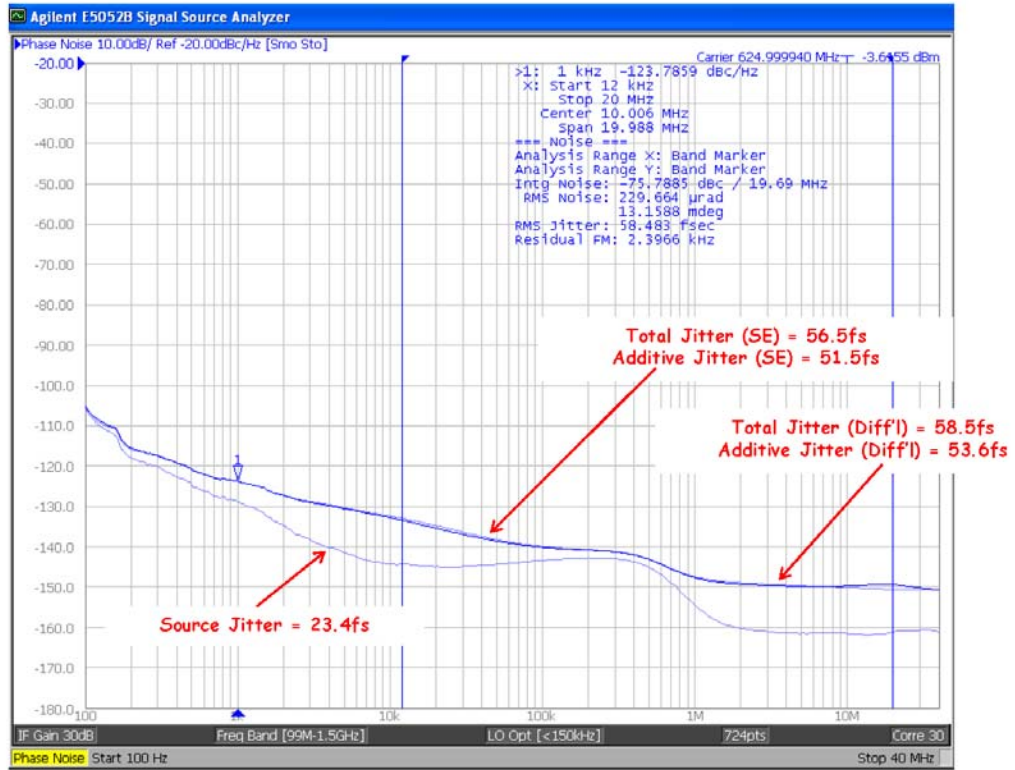

Figure 15. Differential Total Jitter (625 MHz)

Table 23. Differential Total Jitter (625 MHz)

Frequency (MHz)	Diff'l Input Slew Rate (V/ns)	Source Jitter (fs)	Total Jitter (SE) (fs)	Additive Jitter (SE) (fs)	Total Jitter (Diff'l) (fs)	Additive Jitter (Diff'l) (fs)
625	1.0	23.4	56.5	51.5	58.5	53.6

2.11. Input Mux Noise Isolation

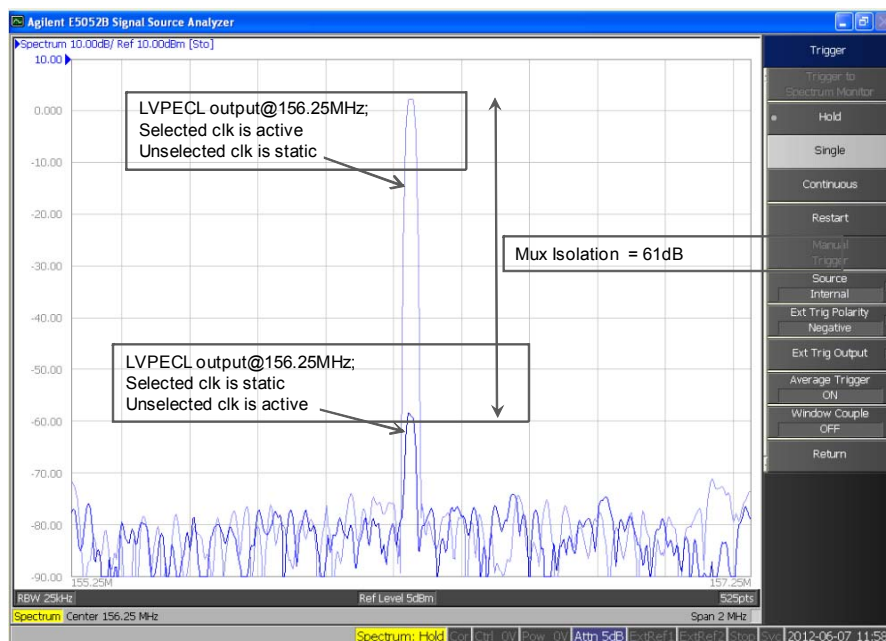

Figure 16. Input Mux Noise Isolation

2.12. Power Supply Noise Rejection

The device supports on-chip supply voltage regulation to reject noise present on the power supply, simplifying low jitter operation in real-world environments. This feature enables robust operation alongside FPGAs, ASICs and SoCs and may reduce board-level filtering requirements. For more information, see “AN491: Power Supply Rejection for Low Jitter Clocks”.

3. Pin Description: 44-Pin QFN

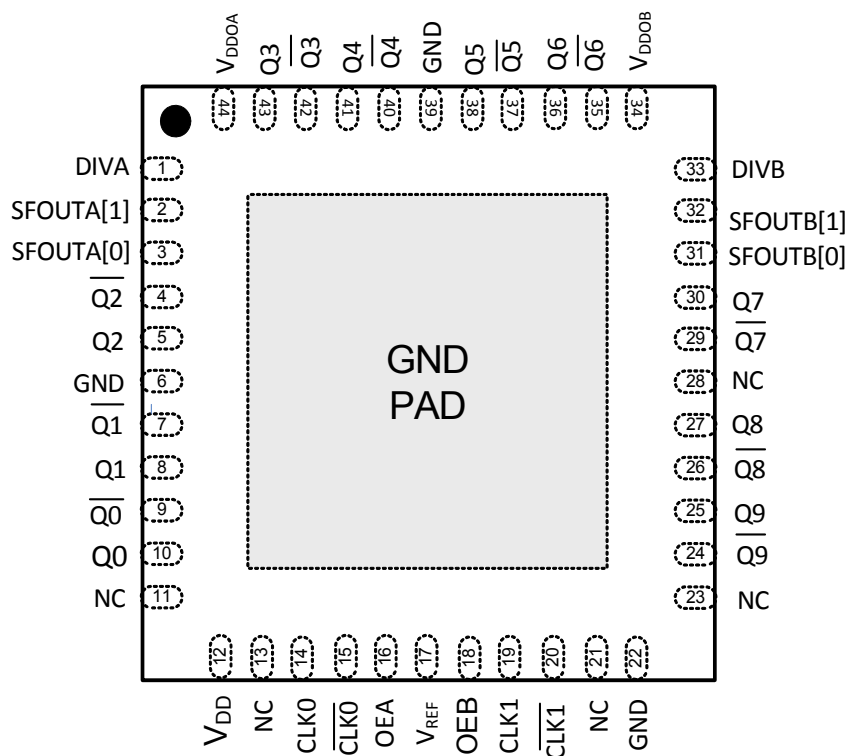

Table 24. Pin Description

Pin #	Name	Description
1	DIVA	Output divider control pin for Bank A Three-level input control. Internally biased at VDD/2. Can be left floating or tied to ground or V _{DD} .
2	SFOUTA[1]	Output signal format control pin for Bank A Three-level input control. Internally biased at VDD/2. Can be left floating or tied to ground or V _{DD} .
3	SFOUTA[0]	Output signal format control pin for Bank A Three-level input control. Internally biased at VDD/2. Can be left floating or tied to ground or V _{DD} .
4	$\overline{Q2}$	Output clock 2 (complement)
5	Q2	Output clock 2
6	GND	Ground
7	$\overline{Q1}$	Output clock 1 (complement)
8	Q1	Output clock 1

Table 24. Pin Description (Continued)

Pin #	Name	Description
9	$\overline{Q0}$	Output clock 0 (complement)
10	Q0	Output clock 0
11	NC	No connect
12	VDD	Core voltage supply Bypass with 1.0 μ F capacitor placed as close to the VDD pin as possible
13	NC	No connect
14	CLK0	Input clock 0
15	$\overline{CLK0}$	Input clock 0 (complement) When the CLK0 is driven by a single-end LVCMOS input, connect CLK0 to VDD/2.
16	OEA	Output enable—Bank A When OE = high, the Bank A outputs are enabled When OE = low, Q is held low and \overline{Q} is held high for differential formats For LVCMOS, both Q and \overline{Q} are held low when OE is set low OEA contains an internal pull-up resistor
17	V _{REF}	Reference voltage for single-ended CMOS clocks. V _{REF} is an output voltage and is equal to V _{DD} /2. It can be used to bias the /CLK input for single ended input clocks. See "2.3. Voltage Reference (VREF)" on page 13.
18	OEB	Output enable—Bank B When OE = high, the Bank B outputs are enabled When OE = low, Q is held low and \overline{Q} is held high for differential formats For LVCMOS, both Q and \overline{Q} are held low when OE is set low OEB contains an internal pull-up resistor.
19	CLK1	Input clock 1
20	$\overline{CLK1}$	Input clock 1 (complement) When the $\overline{CLK1}$ is driven by a single-end LVCMOS input, connect $\overline{CLK1}$ to VDD/2.
21	NC	No connect
22	GND	Ground
23	NC	No connect
24	$\overline{Q9}$	Output clock 9 (complement)
25	Q9	Output clock 9
26	$\overline{Q8}$	Output clock 8 (complement)
27	Q8	Output clock 8
28	NC	No connect
29	$\overline{Q7}$	Output clock 7 (complement)